

COMFORT AIR[®]

Rear Air Suspension System



- Superior comfort
- Outstanding ride
- Improves handling
- Reduces maintenance



To learn more about COMFORT AIR,
call 855.743.3733 or visit www.hendrickson-bus.com

HENDRICKSON
The World Rides On Us[®]

COMFORT AIR® Rear Air Suspension System

Designed with the passenger and driver in mind.

Delivers outstanding passenger and driver comfort along with exceptional handling characteristics for buses and motorhomes.

Superior ride and handling with enhanced equipment protection.

Drawing on 100 plus years of innovation, superior design and quality manufacturing, Hendrickson responded to the customers' requirements with an engineered ride solution. The design is based on our proven HAS™ trailing arm and axle connection technology, with the primary focus on the customer, passenger and driver needs.

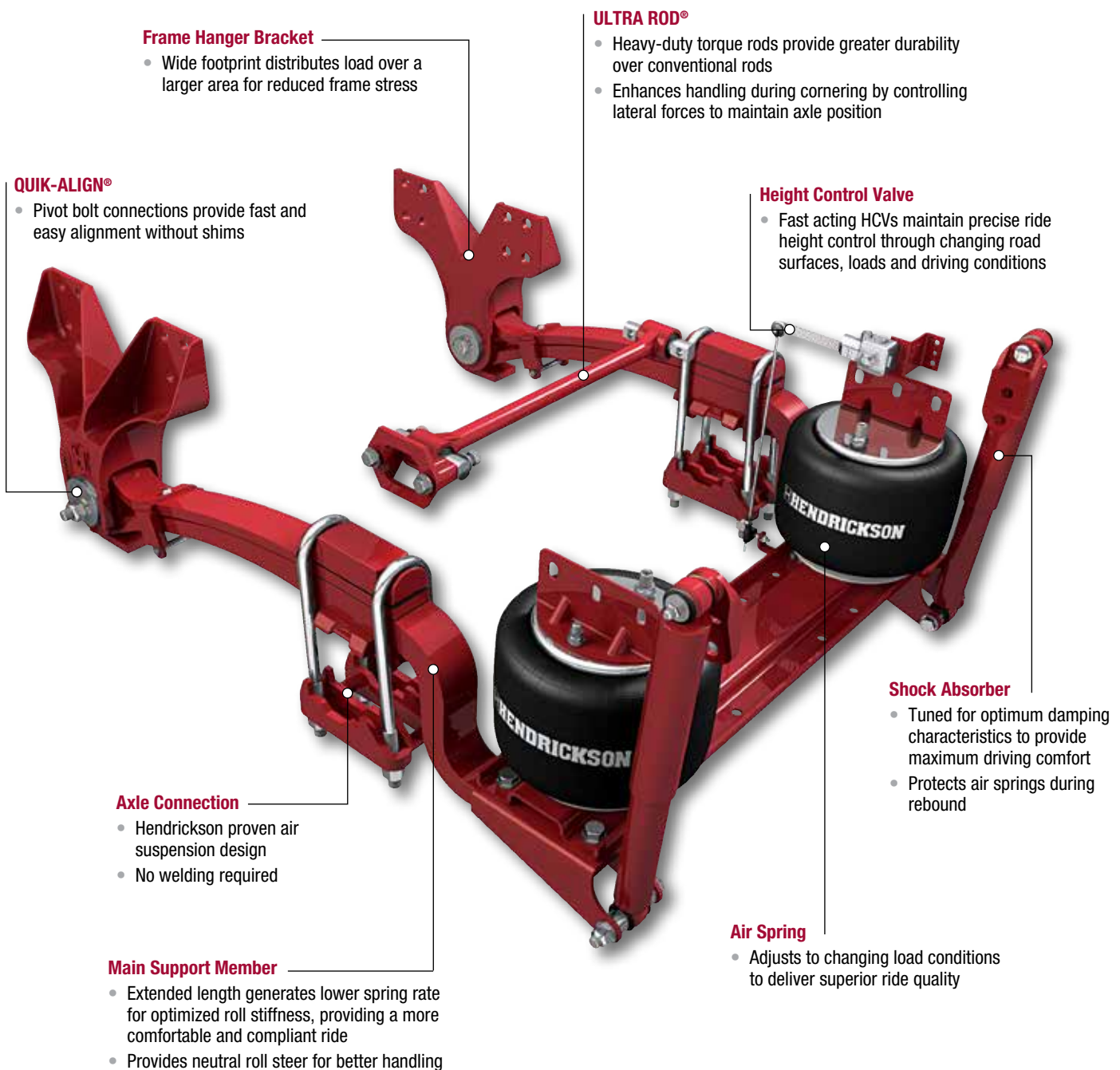

Vehicle Protection and Reduced Maintenance

COMFORT AIR® helps protect your equipment from bumps and potholes in the road. The wider frame hanger bracket disperses forces over a greater area, reducing stress to the frame to help increase the life of the vehicle.

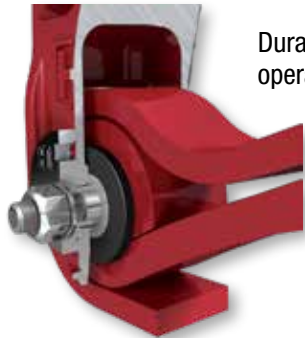

Durable pivot bushing connections provide quiet operation and help extend suspension service life.

Hendrickson's proven QUIK-ALIGN® axle alignment feature reduces maintenance time. QUIK-ALIGN offers a fast method to adjust and set alignment by using two flanged collars that are inserted into slots on each side of the frame hanger bracket. The outboard driver's side flanged collar is eccentric with a 1/2-inch square opening to insert a breaker bar or ratchet.

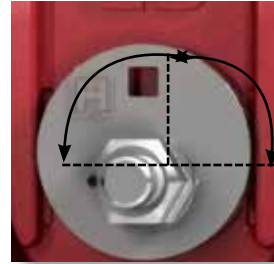

Maximum range of adjustment is ± 90 degrees from 12 o'clock position.

By rotating the eccentric collar clockwise or counter-clockwise, the suspension's axle is moved fore or aft $\pm 1/2$ -inch.

Passenger and Driver Comfort

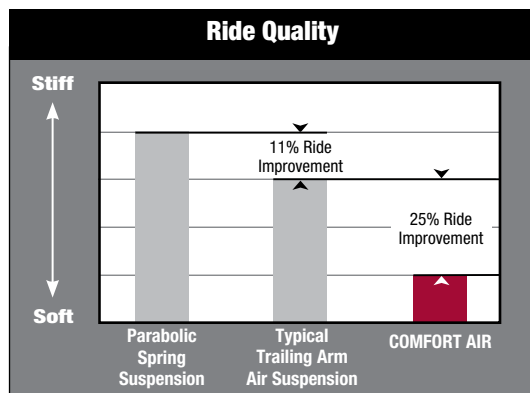

Using advanced spring technology from Hendrickson, COMFORT AIR's main support member has an elongated design for optimized roll stiffness. This provides a softer ride and greater protection from the effects of road shock on your chassis, equipment, drivers and passengers.

A longer main support member allows the air springs to carry more of the vertical load to provide a softer ride.

The axle center is on a horizontal line with the pivot point, generating neutral roll steer characteristics for improved handling quality while cornering.

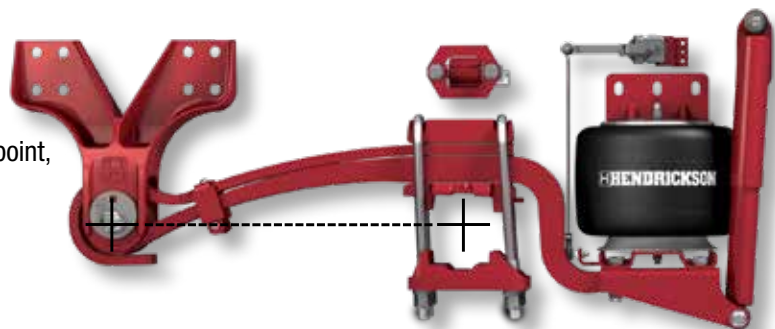

COMFORT AIR® Specifications

Suspension Rating ¹ (lbs.)	15,000 — 23,000
GVW (lbs.)	40,000
Ride Heights (in.)	8.5 — 10.5 (with straight frames)

COMFORT AIR® is approved for most truck, bus and motorhome applications.

Contact Hendrickson and the respective vehicle manufacturer for approval of specific/additional applications. All applications must comply with applicable Hendrickson specifications and be approved by the respective vehicle manufacturer with the vehicle in its original as-built configuration. Contact Hendrickson for additional details regarding specifications, applications, capacities, and operation, service and maintenance instructions.

1. COMFORT AIR is approved for up to 10 percent off-highway use.



Hendrickson Genuine Parts provide the same quality components installed in Hendrickson original equipment suspensions — consisting of the same design, construction, performance and durability. There's only one way to maintain and protect your suspension's original performance. Ask for the name that is synonymous with the finest manufactured suspensions in the world — Hendrickson.

Actual product performance may vary depending upon vehicle configuration, operation, service and other factors.
All applications must comply with applicable Hendrickson specifications and must be approved by the respective vehicle manufacturer with the vehicle in its original, as-built configuration.
Contact Hendrickson for additional details regarding specifications, applications, capacities, operation, service and maintenance instructions.

Call Hendrickson at **630.910.2800** or **855.RIDERED (743.3733)** for additional information.



TRUCK COMMERCIAL VEHICLE SYSTEMS
800 South Frontage Road
Woodridge, IL 60517-4904 USA
855.RIDERED (743.3733)
630.910.2800 • Fax 630.910.2899

www.hendrickson-intl.com     

45745-173 Rev I 02-25

© 2010 - 2025 Hendrickson USA, L.L.C. All Rights Reserved. All trademarks shown are owned by Hendrickson USA, L.L.C., or one of its affiliates, in one or more countries. Information contained in this literature was accurate at the time of publication. Product changes may have been made after the copyright date that are not reflected. Printed in United States of America