

H PARTS LIST

HTB® 175M Mechanical Rear Suspension for Workhorse UFO Motorhome Chassis

LIT NO: SP-213

DATE: May 2026

REVISION: E

CONTENTS

DESCRIPTION	PAGE
Parts Lists	2
Special Tools	4

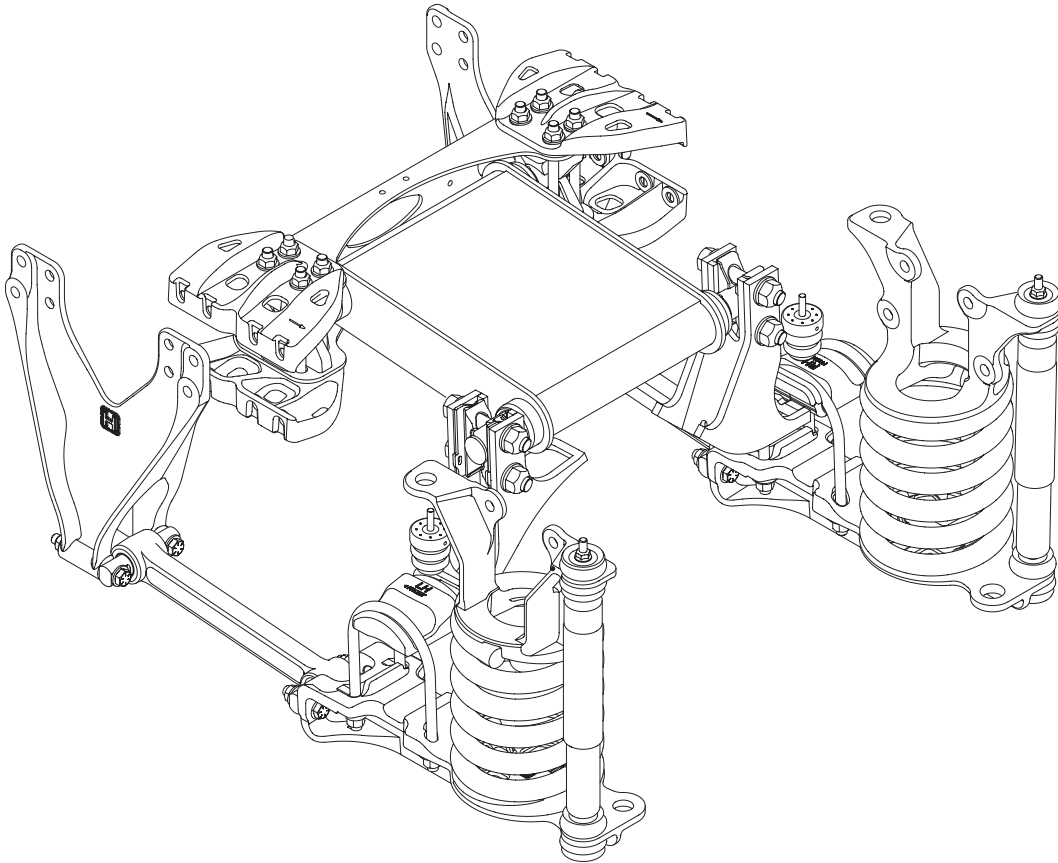

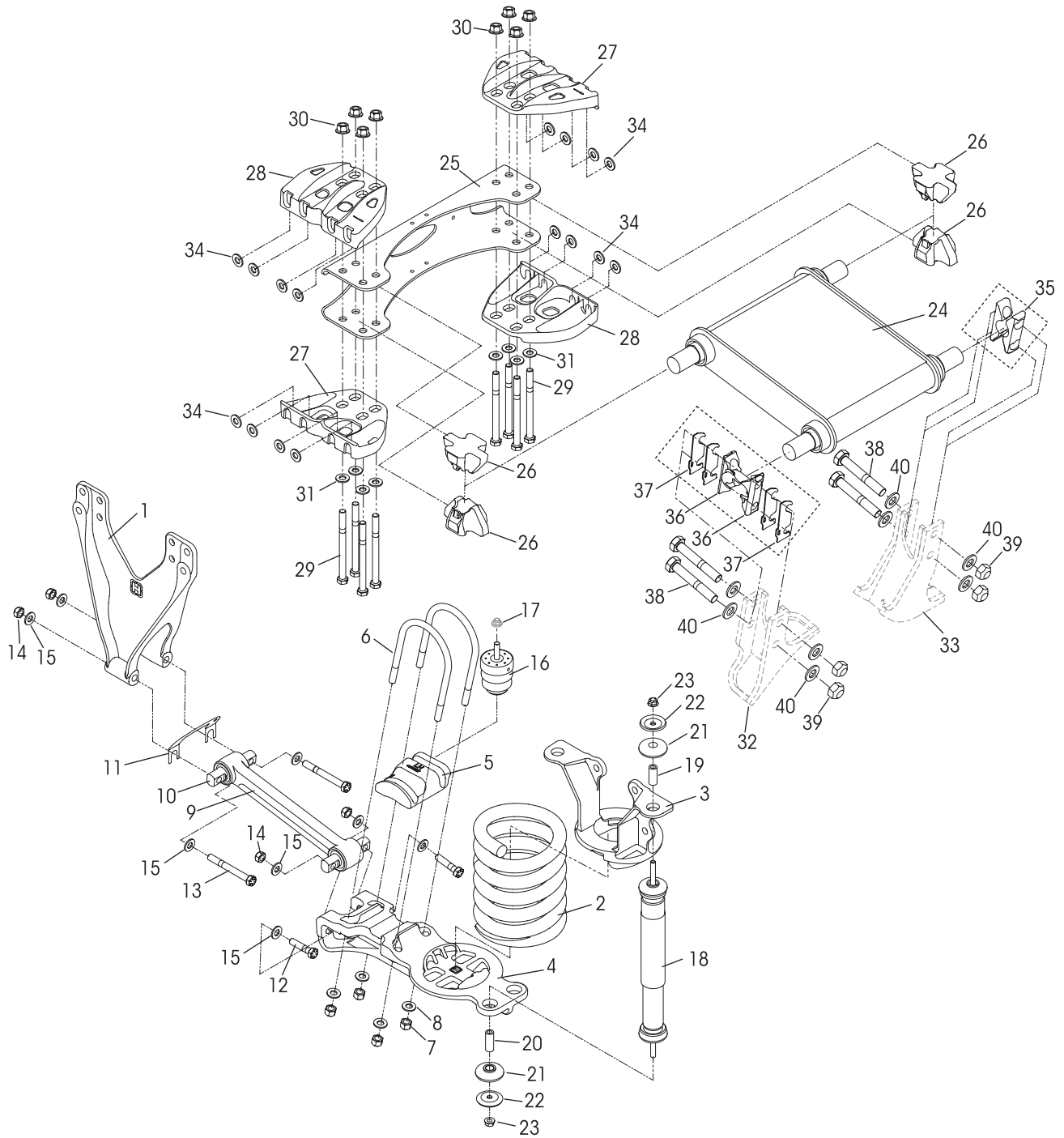



HTB® 175M for Workhorse UFO Motorhome Chassis

KEY NO.	PART NO.	DESCRIPTION	VEHICLE QTY.	KEY NO.	PART NO.	DESCRIPTION	VEHICLE QTY.
1	66512-000	Frame Hanger	2	21	66900-000	**Rubber Isolator	4
2	66319-000	Coil Spring – 17.5K	2	22	66899-000	**Retaining Washer	4
3	66315-000	Coil Spring Hanger	2	23	66898-000	**M12 Flange Locknut	4
4	66317-000	*Lower Coil Spring Bracket	2		66513-002	*Torque Box Cross Member Assembly, Includes Key Nos. 24-31	1
5		*Axle Top Pad		24	64785-005	Torque Box, <i>Replaces 64785-004</i>	1
	66316-001	Left Hand	1	25	67478-000	Cross Member C-Channel <i>Replaces 64970-000</i>	1
	66316-002	Right Hand	1	26	65144-000	Cross Member Bar Pin Clamp (Aluminum) *Cross Member Gusset	4
	58821-022	Axle Clamp Fastener Kit, Axle Set, Includes Key Nos. 6-8		27	66503-001	RH Top, LH Bottom	2
6	66323-000	**5/8"-18 UNF x 9.45" U-bolt	4	28	66503-002	LH Top, RH Bottom	2
7	66897-000	**5/8"-18 UNF U-bolt Tail Nut	8	29	32043-016	5/8"-11 UNC x 8" Hex Bolt	8
8	22962-004	**5/8" Hardened Flat Washer	8	30	66637-000	5/8"-11 UNC Flange Locknut <i>Replaces 47764-000</i>	8
9	48411-015	Torque Rod Assembly, Includes Key No.10	2	31	22962-004	5/8" Hardened Flat Washer	8
10	47691-000L	Torque Rod Bushing	4	32		***Torque Box Axle Bracket - Dana (Short)	1
11	57856-000	1/32" Torque Rod Shim (as required)	4	33		***Torque Box Axle Bracket - Dana (Long)	1
	49176-027	Torque Rod Fastener Kit, Axle Set, Includes Key Nos. 12-15		34	22962-004	5/8" Hardened Flat Washer	16
12	32043-002	**5/8"-11 UNC x 2 3/4" Hex Bolt	4	35	66174-000L	****Non-Adjustable Axle Bracket Bar Pin Clamp	2
13	32043-019	**5/8"-11 UNC x 5 1/2" Hex Bolt	4	36	66274-000	****Adjustable Axle Bracket Bar Pin Clamp	2
14	47764-000	**5/8"-11 UNC Locknut	8	37	65737-001	****Axle Bracket Shims	4
15	22962-004	**5/8" Hardened Flat Washer	16		66027-002	Torque Box Axle Fastener Kit, Axle Set, Includes Key Nos. 38-40	
16	66308-001	Auxiliary Bumper	2	38	58917-003	**3/4"-10 UNC x 5 1/2" Hex Bolt	4
17		**M10 Flanged Locknut	2	39	49842-000	**3/4"-10 UNC Locknut	4
	60961-149	Shock Absorber Service Kit, One Side, Includes Key Nos. 18-23		40	22962-001	**3/4" Hardened Flat Washer	8
18	66321-000	**Shock Absorber Assembly M12 Stud Mount, Includes Key Nos.19-20	2	Not Shown	70867-001	P-80 Lubricant - 10 ml.	per Bushing 1
19		**Upper Shock Spacer Length 1 5/16"	2				
20		**Lower Shock Spacer Length 2 3/16"	2				

NOTE: * These parts are no longer in production, contact Hendrickson Truck Parts for available options.

** Item included in kit/assembly only, part not sold separately.

*** Not supplied by Hendrickson, used for reference only. Hendrickson is not responsible for components supplied by the vehicle manufacturer. For assistance with maintenance and rebuild instructions on these components see vehicle manufacturer.

**** In the aftermarket, it is acceptable to replace the non-adjustable axle bracket bar pin clamp (Key No. 35) with the adjustable bar pin clamp and axle bracket shims (Key No. 36 and 37).



■ Special Tools

ULTRA ROD® TORQUE ROD BUSHING (FUNNEL) TOOL



Hendrickson Part No. 66086-001L

Actual product performance may vary depending upon vehicle configuration, operation, service and other factors. All applications must comply with applicable Hendrickson specifications and must be approved by the respective vehicle manufacturer with the vehicle in its original, as-built configuration. Contact Hendrickson for additional details regarding specifications, applications, capacities, and operation, service and maintenance instructions.

Call Hendrickson at 630.910.2800 or 855.RIDERED (855.743.3733) for additional information.



www.hendrickson-intl.com

TRUCK COMMERCIAL VEHICLE SYSTEMS
800 South Frontage Road
Woodridge, IL 60517-4904 USA
855.743.3733 (Toll-free U.S. and Canada)
630.910.2800 (Outside U.S. and Canada)
Fax 630.910.2899

SP-213 Rev E 05-26

© 2006 – 2026 Hendrickson USA, L.L.C. All Rights Reserved. All trademarks shown are owned by Hendrickson USA, L.L.C., or one of the affiliates, in one or more countries. Information contained in this literature was accurate at the time of publication. Product changes may have been made after the copyright date that are not reflected.

Printed in United States of America