

H ULTRAA-K®
SLIDER SUSPENSION SYSTEMS

UTKNT 40K Specifications

LIT NO: L1231

DATE: March 2019 REVISION: C

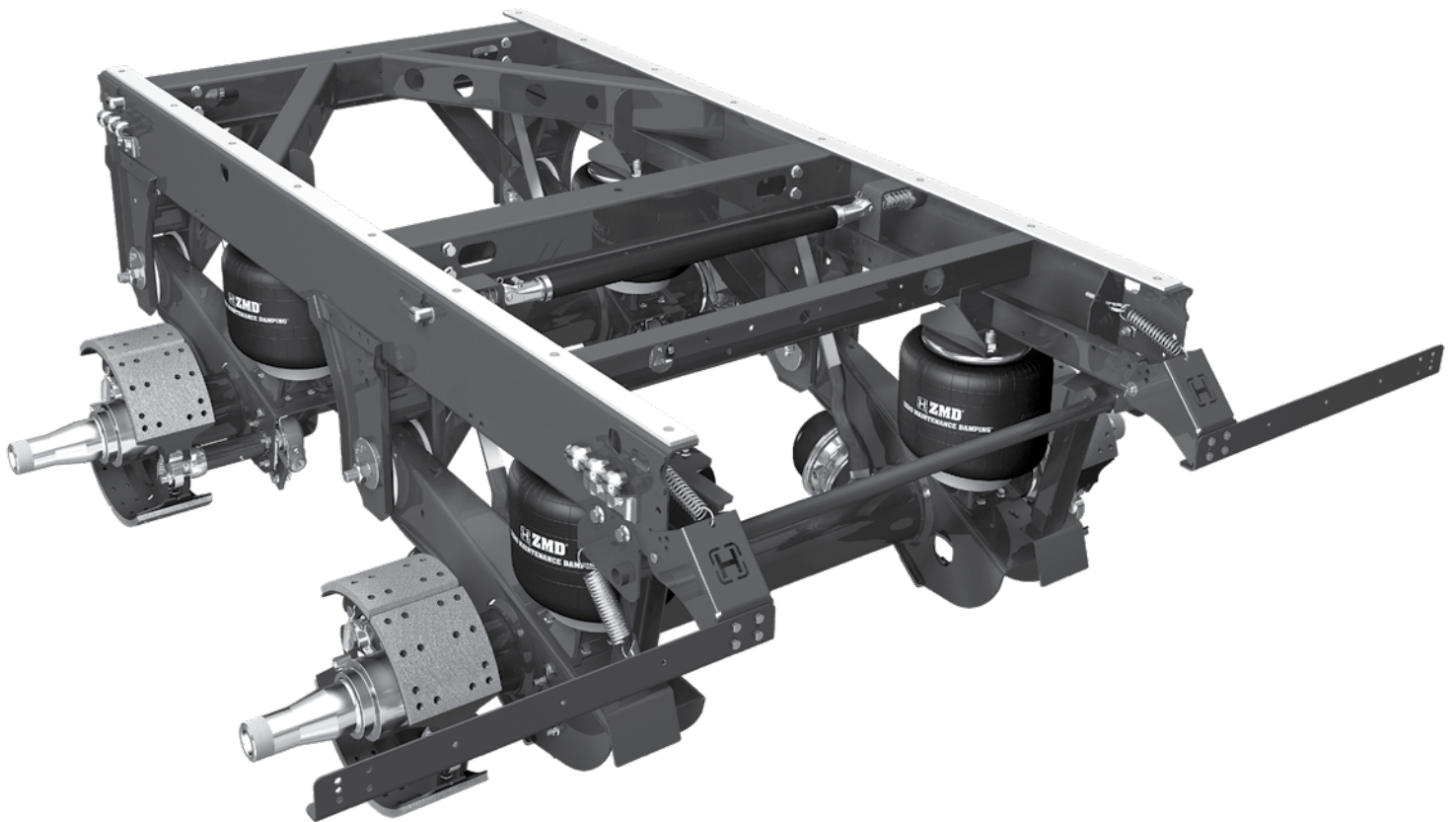



SYSTEM CAPACITY*	40,000 lbs. (18 000 kg)
APPLICATION	On-highway
TRAILER TYPES	U.S.A. and Canada: Dry and refrigerated van Mexico, Central and South America: None
AXLE DATA	Diameter: 5.75-inch LDA™ Large-Diameter Axle Arrangement: Tandem Track: 77.5-inch Spread: 49-inch
FRAME TYPES	Steel only: 102-inch wide trailers (48-inch wide slider boxes)
BASE MODEL DESCRIPTION	ULTRAA-K® UTKNT 40K slider suspension system consisting of 49-inch spread, 48-inch wide slider box with two 16-inch ride height suspensions, HN spindles, 16.5- x 7-inch brakes with Abex 3030-197 brake lining, ABS brackets, QUIK-ALIGN® pivot connection, QUIK-DRAW® pin-pull mechanism, standard Cam Tube System™, ZMD® ZERO MAINTENANCE DAMPING® technology, pivoting mud flap bracket mounting and pre-installed HCV.



*System capacity refers to the suspensions, axles and slider. Ratings for brakes and wheel-end components differ depending upon options chosen.

AXLE SPREAD (inches)	RIDE HEIGHT (inches)	SYSTEM HEIGHT (inches)	FRONT AXLE LOCATION (inches)	JOUNCE (inches)	REBOUND (inches)	WEIGHT (pounds)
49	16	24.25	25.4	2.5	4	1,322

Note: Weight includes 48-inch wide slider, suspensions, HN LDA™ Large-Diameter Axle (5.75-inch) and foundation brake components (body rail weights not included). Includes air tank mounting brackets, pivoting mud flap brackets and preinstalled height control valve. Does not include SURELOK® or box shims.

SPECIFICATIONS

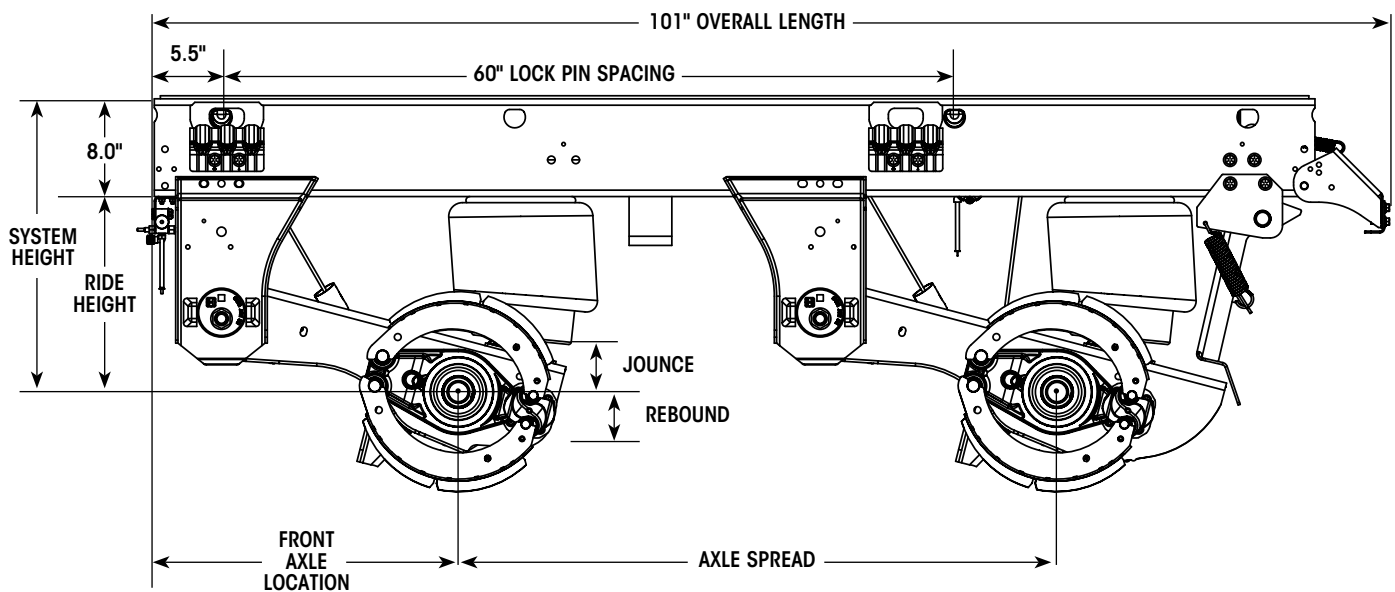



SPINDLE TYPE	TUBE O.D. (inches)	BEARINGS			
		INNER CONE	OUTER CONE	INNER CUP	OUTER CUP
HN	5.75	HM18248	HM212049	HM218210	HM212011
HP	5.75	HM518445		HM518410	

HENDRICKSON MAXX22T™

Hendrickson trailer air disc brake system specifically designed to optimize performance for North American trailer applications, with WABCO brake technology, features premium offerings including the lightweight Dura-Light Hub® option, TIREMAAX®, and RTR® READY-TO-ROLL® wheel-end packages.

RTR® READY-TO-ROLL®

Choose from a broad mix of offerings to customize running gear for your specific application. Wheel-end options consist of aluminum, ductile iron or Dura-Light Hub® in a variety of standard and extended service packages.

BRAKE OPTIONS

For complete details on the wide range of brake options available including lining choices, brake ratings and FMVSS/CMVSS 121 brake certifications, refer to publication L809, *Brake Certifications*. Air disc brake packages available on ULTRAA-K™ models. Please contact Hendrickson for assistance.

BRAKE CHAMBERS

Industry standard brake chambers with pushrod length of 9.75-inches and clamping / port orientation of zero degrees are compatible.

BRAKE ADJUSTERS

Industry standard 5.5- and 6-inch brake adjusters are compatible.

DUST SHIELD

Clamp-on dust shield provides protection for both drum and air disc brakes — factory or OEM installed.

PRE-INSTALLED HEIGHT CONTROL VALVE

Options include standard, non-dump, integrated auto-dump and DST® Dock Stabilizing Technology™.

SURELOK®

Dock height lock that maintains trailer at deck height while minimizing trailer walk during loading and unloading.

STINGER

Bolt-on bracket available in 32- or 36-inch lengths — road and curbside mounting ready.

MANUAL STOP BAR

Efficiently assists the driver in slider box repositioning.

FACTORY PRE-ALIGNED SLIDERS

Ensures accurate parallelism between two neutral-toe axles.

