

# **H** TECHNICAL PROCEDURE

## PARASTEER

SUBJECT: Service Instructions

LIT NO: 17730-234

DATE: July 2001

REVISION: B

### TABLE OF CONTENTS

<b>Section 1</b>	<b>Introduction</b> . . . . .	2
<b>Section 2</b>	<b>Important Safety Notice</b> . . . . .	2
<b>Section 3</b>	<b>Product Description</b> . . . . .	4
<b>Section 4</b>	<b>Preventive Maintenance</b>	
	Beam Assembly, Wear Pads, and Transverse Torque Rod . . . . .	5
	Shock Absorber . . . . .	6
	Steering Stabilizer Shock . . . . .	7
	Ride Height Setting . . . . .	7
<b>Section 5</b>	<b>Component Replacement</b>	
	Frame Hanger . . . . .	9
	Beam Assembly and Wear Pads . . . . .	10
	Beam Assembly Bushings	
	Rubber Bushing . . . . .	12
	PTFE Bushing . . . . .	13
	Crossmember . . . . .	14
	Transverse Leaf . . . . .	15
	Transverse Torque Rod . . . . .	16
	Transverse Torque Rod Bushing . . . . .	16
	Air Spring . . . . .	18
	Air Spring Frame Hanger and Reinforcement Bracket . . . . .	19
	Shock Absorber . . . . .	20
	Axle Seat . . . . .	20
	Ride Height Control Valve . . . . .	22
<b>Section 6</b>	<b>Air Plumbing Diagram</b> . . . . .	23
<b>Section 7</b>	<b>Tightening Torque Specification Chart</b> . . . . .	24

## SECTION 1

# Introduction

This publication is to acquaint and assist maintenance personnel in preventive maintenance and rebuild of the HPS ParaSteer suspension system.

Hendrickson reserves the right to make changes and improvements to its products and manuals at any time. Contact Hendrickson Tech Services at 630.910.2800 for information on the latest version of this manual.

---

**NOTE** Use only genuine Hendrickson parts for servicing this suspension system. Most Hendrickson parts can be identified by the Hendrickson trademark.

---

## SECTION 2

# IMPORTANT SAFETY NOTICE

Proper maintenance service and repair is important to the reliable operation of the suspension. The procedures recommended by Hendrickson and described in this technical publication are methods of performing such maintenance, service and repair.

The warnings and cautions should be read carefully to help prevent personal injury and to assure that proper methods are used. Improper servicing may damage the vehicle, cause personal injury, render it unsafe in operation, or void manufacturer's warranty.

Failure to follow the safety precautions in this manual can result in personal injury and/or property damage. Carefully read, understand and follow all safety related information within this publication and on all decals.

### EXPLANATION OF SIGNAL WORDS

Hazard "Signal Words" (Danger-Warning-Caution) appear in various locations throughout this publication. Information accented by one of these signal words must be observed to help minimize the risk of personal injury to service personnel, or possibility of improper service methods which may damage the vehicle or render it unsafe. Additional Notes or Service Hints are utilized to emphasize areas of procedural importance and provide suggestions for ease of repair. The following definitions indicate the use of these signal words as they appear throughout the publication.

 **DANGER**

INDICATES IMMEDIATE HAZARDS WHICH WILL RESULT IN SEVERE PERSONAL INJURY OR DEATH.

 **WARNING**

INDICATES HAZARDS OR UNSAFE PRACTICES WHICH COULD RESULT IN SEVERE PERSONAL INJURY OR DEATH.

 **CAUTION**

INDICATES HAZARDS OR UNSAFE PRACTICES WHICH COULD RESULT IN DAMAGE TO MACHINE OR MINOR PERSONAL INJURY.

---

**NOTE** An operating procedure, practice condition, etc. which is essential to emphasize.

---

**SERVICE HINT** A helpful suggestion which will make the servicing being performed a little easier and/or faster.

---

## WARNINGS AND CAUTIONS

There are various warnings and cautions that should be read carefully to minimize the risk of personal injury and to assure that proper methods are used. Improper servicing may damage the vehicle or render it unsafe in operation.

### WARNING

#### LOAD CAPACITY

HENDRICKSON SUSPENSION REMINDS USERS TO ADHERE TO THE PUBLISHED CAPACITY RATINGS FOR THE SUSPENSIONS. ADD-ON AXLE ATTACHMENTS AND OTHER LOAD TRANSFERRING DEVICES CAN INCREASE THE SUSPENSION LOAD ABOVE THE RATED AND APPROVED CAPACITIES WHICH COULD RESULT IN FAILURE AND LOSS OF VEHICLE CONTROL, POSSIBLY CAUSING PERSONAL INJURY OR PROPERTY DAMAGE.

### WARNING

#### MODIFYING COMPONENTS

DO NOT MODIFY OR REWORK PARTS. DO NOT USE SUBSTITUTE PARTS OF THE SUSPENSION. USE OF A MODIFIED OR REPLACEMENT PARTS NOT AUTHORIZED BY HENDRICKSON MAY NOT MEET HENDRICKSON'S SPECIFICATIONS, AND CAN RESULT IN FAILURE OF THE PART, LOSS OF VEHICLE CONTROL, AND POSSIBLE PERSONAL INJURY OR PROPERTY DAMAGE. USE ONLY HENDRICKSON AUTHORIZED REPLACEMENT PARTS DO NOT MODIFY PARTS WITHOUT AUTHORIZATION FROM HENDRICKSON.

### WARNING

#### TORCH/WELDING

DO NOT USE A CUTTING TORCH TO REMOVE ANY ATTACHING FASTENERS. THE USE OF HEAT ON SUSPENSION COMPONENTS WILL ADVERSELY AFFECT THE STRENGTH OF THESE PARTS. A COMPONENT DAMAGED IN THIS MANNER CAN RESULT IN THE LOSS OF VEHICLE CONTROL AND POSSIBLE PERSONAL INJURY OR PROPERTY DAMAGE.

### CAUTION

#### PROCEDURES AND TOOLS

A MECHANIC USING A SERVICE PROCEDURE OR TOOL WHICH HAS NOT BEEN RECOMMENDED BY HENDRICKSON MUST FIRST SATISFY HIMSELF THAT NEITHER HIS SAFETY NOR THE VEHICLE'S SAFETY WILL BE JEOPARDIZED BY THE METHOD OR TOOL SELECTED. INDIVIDUALS DEVIATING IN ANY MANNER FROM THE INSTRUCTIONS PROVIDED ASSUME ALL RISKS OF CONSEQUENTIAL PERSONAL INJURY OR DAMAGE TO EQUIPMENT INVOLVED.

### WARNING

#### PERSONNEL PROTECTIVE EQUIPMENT

ALWAYS WEAR PROPER EYE PROTECTION AND OTHER REQUIRED PERSONAL PROTECTIVE EQUIPMENT TO HELP PREVENT PERSONAL INJURY WHEN YOU PERFORM VEHICLE MAINTENANCE, REPAIR OR SERVICE.

## SECTION 3 DESCRIPTION

Based on Hendrickson's proven ParaLift Ultra steerable lift axle system, ParaSteer solves the adverse effects common to front air suspensions. Its durable design and transverse leaf (9/98-12/99) or transverse torque rod (1/00-current) improve roll stiffness, while providing a degree of ride comfort unmatched by previous air suspensions.

- Four-bar linkage design — maintains correct steering geometry under all conditions, minimizing steer error caused by rough road, hard cornering and braking. Results in more precise and accurate control for operator.
- Heavy-duty bushings eliminate lubrication requirements and provide exceptional durability.
- Height control valve maintains precise ride height control, regardless of changing road surfaces, load and driving conditions.
- Heavy-duty air spring design positions load directly over axle for increased equipment protection, as well as premium passenger and operator comfort.
- Transverse leaf (9/98-12/99) or transverse torque rod (1/00-Current) resists lateral axle movement to increase roll stiffness of chassis.
- Shock absorbers tuned for optimum damping to further enhance ride quality.

All HPS ParaSteer front steer axle suspensions are intended for installation on standard vehicles from widths of 33.94" to 34.19" or 34.50" to 34.81". It has a capacity of up to 14,600 pounds. HPS is available with I-beam style front steering axles, S-cam brakes, automatic slack adjuster. Weight without axle assembly is 512 lbs. (232 kg).

**Figure 3-1**

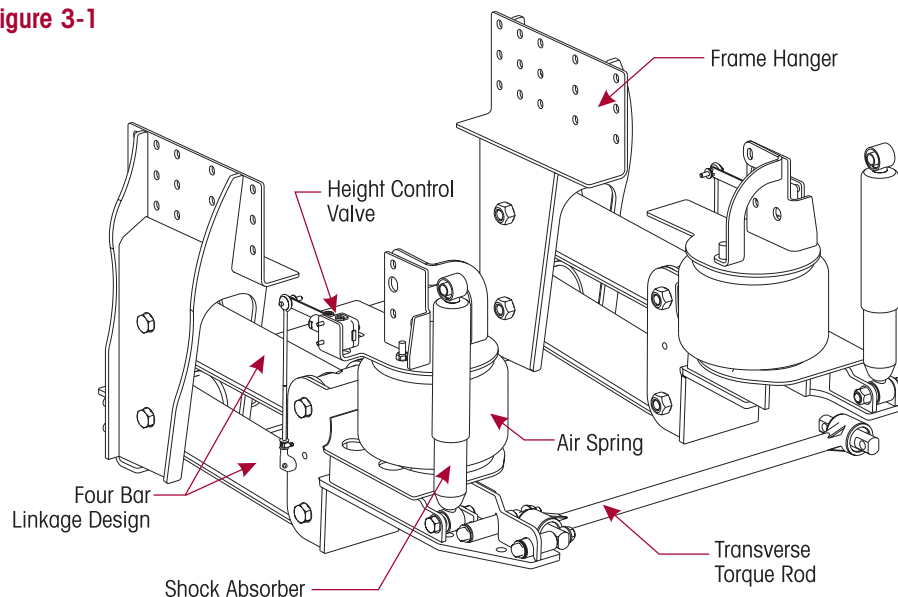

## SECTION 4 PREVENTIVE MAINTENANCE

### BEAM ASSEMBLY, WEAR PADS, AND TRANSVERSE TORQUE RODS

In normal use these components will function satisfactorily through the life of the vehicle, even though the components may show some wear.

#### NOTE

If one bushing or wear pad in beam, or one bushing in torque rod requires replacement, Hendrickson recommends all bushings and all wear pads in beam, or both bushings in torque rod be replaced.

For instructions on beam bushing, wear pads, or transverse torque rod bushing replacement see the Component Replacement Section of this publication.

#### VEHICLES PRODUCED 9/98-12/99

Figure 4-1

An indication that the Rubber Bushing, PTFE Bushing (see Figure 4-1) and/or Wear Pads are worn is when the suspension exhibits one or more of the following conditions:

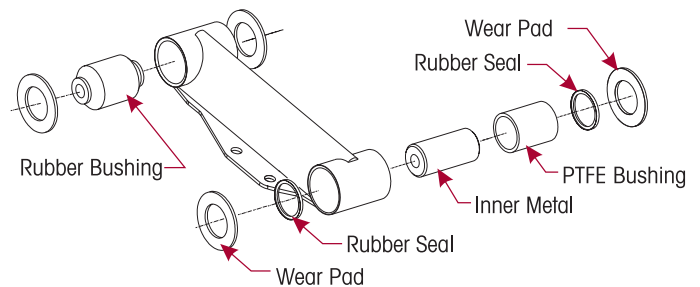

- Air Springs are shifted to the left or right side of vehicle. See Figure 4-2.
- Excessive lateral movement of the axle (axle movement evaluation).
- Wear Pads show successive grooves as shown in Figure 4-3.
- Suspension noise during operation. Contact Hendrickson Tech Service for more information.

If one or more of the above conditions are experienced, replacement is required.

Figure 4-2

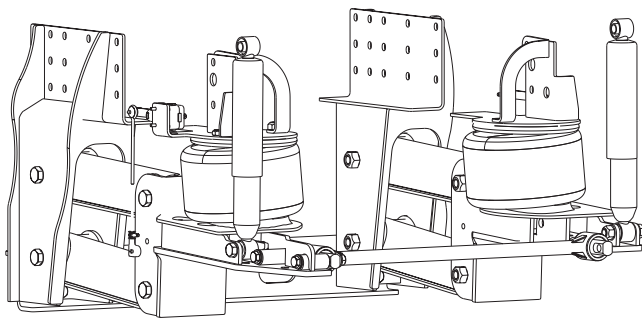

Figure 4-3



## VEHICLES PRODUCED 1/00-CURRENT

**Figure 4-4**

An indication that the Rubber Bushing, Wear Pads (See Figure 4-4) and/or Transverse Torque Rod Bushings are worn is when the suspension exhibits one or more of the following conditions:

- Excessive lateral movement of the axle (axle movement evaluation).
- Wear Pads show successive grooves as shown in Figure 4-3
- Worn or loose Transverse Torque Rod Bushing.
- Suspension noise during operation. Contact Hendrickson Tech Service for more information.

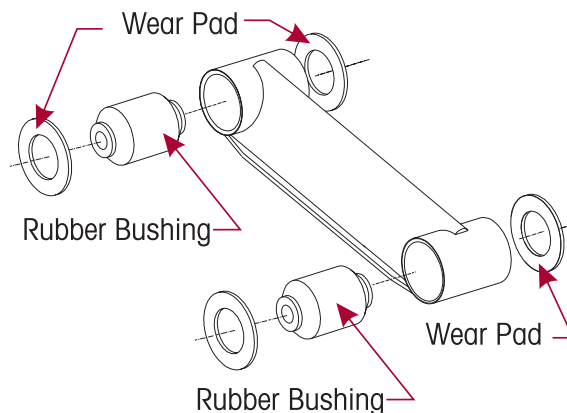

If one or more of the above conditions are experienced, replacement is required.

## SHOCK ABSORBER

Inspection of the shock absorber can be performed by doing a heat test, and a visual inspection. For instructions on shock absorber replacement see the Component Replacement Section of this publication. It is not necessary to replace shock absorbers in pairs if one shock absorber requires replacement.

### VISUAL INSPECTION

1. Inspect bushings for damage or excessive wear.
2. Inspect the shock absorber body and dust tube for damage.
3. Inspect shock absorber for excessive oil leaks. (Oil misting is normal and acceptable).

**Figure 4-5**

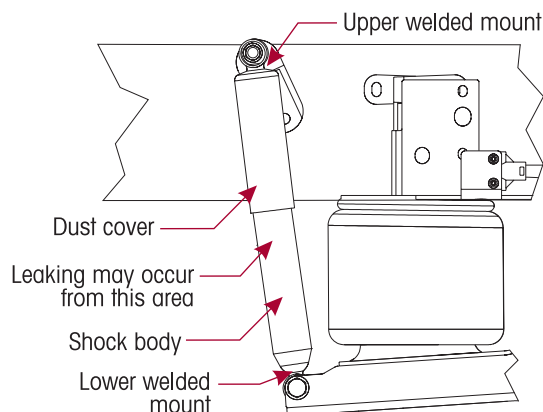

### HEAT TEST

1. Drive vehicle at moderate speeds for fifteen minutes.



### WARNING

DO NOT GRAB SHOCK ABSORBER AS IT COULD POSSIBLY CAUSE PERSONAL INJURY

2. Touch the shock absorber body carefully below the dust cover. See Figure 4-5.
3. Touch frame to get ambient reference, a warm shock is acceptable; a cold shock should be replaced.

### STEERING STABILIZER SHOCK (IF EQUIPPED)

Inspection of the stabilizer shock can only be performed visually.

1. Inspect the bushings for damage or excessive wear.
2. Inspect the stabilizer shock body and dust tube for damage.
3. Inspect the stabilizer shock for excessive oil leaks.

### RIDE HEIGHT SETTING

The proper ride height is essential for maximum ride quality and performance. Proper adjustment of the ride height control valve is described below. If the height control valve or the linkage assembly become damaged they will require replacement. See the Component Replacement Section in this publication.

1. Place the vehicle on level floor.
2. Free and center all suspension joints by slowly moving the vehicle back and forth without applying the brakes. When coming to a complete stop make sure the parking brakes are released.
3. Chock the rear wheels of the vehicle.
4. Loosen the clamp on the adjustable extension rod joint.
5. Remove the locknut and washer at height control valve leveling arm.

**Figure 4-6**

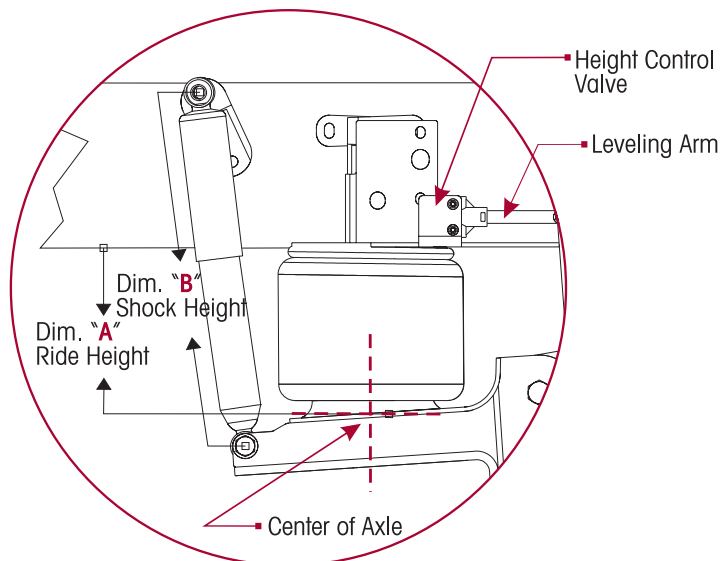

- Verify that air system is at full operating pressure. Exhaust the air in the air springs to relax the suspension. Then refill the air springs to proper ride height. The normal running length of the shock absorber measures the ride height for the HPS from center of eye to center of eye, see Figure 4-6.

The specific running length of the shock absorber varies for specific OEM applications as shown in the matrix. The matrix also shows the shock height for the Hendrickson HAS suspension, this is to be used for vehicles also equipped with the HAS suspension and is for reference only.

	DIMENSION A	DIMENSION B	DIMENSION C (not shown)
OEM AND MODEL	RIDE HEIGHT	SHOCK ABSORBER LENGTH AT RIDE HEIGHT WITH A TOLERANCE OF 1/4"	HAS SHOCK LENGTH (For reference only)
BLUE BIRD - RE/QBRE	5.75"	18"	21.75
BLUE BIRD -TCFE/CSFE	7.5"	18.5"	24.75
BLUE BIRD -TSFE/CIFE	9.5"	18.5"	24.75
BLUE BIRD -TCFE FLAT FLOOR	9.5"	18.5"	24.75
BLUE BIRD - A3RE	7.5	18.5"	21.75
BLUE BIRD - A3FE	7.5	18.5"	24.75
STANDARD	8" & 7"	18.0"	21.75

- Use a 1/8" wooden dowel rod (golf tee) to set the neutral position for the height control valve by aligning hole in leveling arm with hole in control valve cover, as shown in Figure 4-7.

**WARNING**

DO NOT USE A METAL ROD OR NAIL TO SET THE NEUTRAL POSITION AS THIS MAY CAUSE DAMAGE TO THE HEIGHT CONTROL VALVE.

- Reposition the extension rod in the rubber joint.
- Attach the washer and locknut and tighten to 100-150 inch pounds torque.
- Tighten the clamp on the rubber joint with a screwdriver until securely fastened.
- Vehicles produced after 1/00** are equipped with two height control valves. Verify proper ride height on both sides of vehicle, and repeat this procedure for the second valve.

**NOTE**

During cycle operation of the height control valve it is normal to experience a limited amount of exhaust noise.

**Figure 4-7**

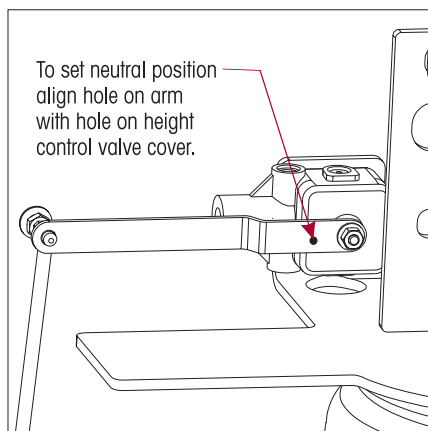



## SECTION 5

# COMPONENT REPLACEMENT

### FRAME HANGER

The frame hanger is unlikely to require removal or replacement. In normal use it should function satisfactorily throughout the life of the vehicle. Replacement is only required when the frame hanger has been damaged.

#### DISASSEMBLY

1. Chock wheels of axle.
2. Raise frame of vehicle to remove load from suspension.



#### WARNING

VEHICLE MUST BE FIRMLY SUPPORTED WITH JACK STANDS PRIOR TO SERVICING. FAILURE TO DO SO COULD RESULT IN PERSONAL INJURY OR PROPERTY DAMAGE.

3. Verify that the air is removed from the system.
4. Remove beam assemblies, (see beam assembly Component Replacement Section of this publication).
5. Remove the  $\frac{3}{4}$ " bolts, washers, and locknuts that connect crossmember to frame hanger.
6. Remove the frame hanger from the vehicle by removing the fasteners per the vehicle manufacturer specifications.
7. Remove frame hanger.

#### ASSEMBLY

1. Install frame hanger by attaching fasteners per vehicle manufacturer specification.
2. Install the  $\frac{3}{4}$ " bolts, washers, and locknuts which connect the crossmember to frame hanger. Tighten locknuts to 260-320 foot pounds torque.
3. Attach the beam assemblies (see beam assembly Component Replacement Section of this publication).
4. Remove the jack stands and lower the frame of vehicle.
5. Air up the system.

**Figure 5-1**

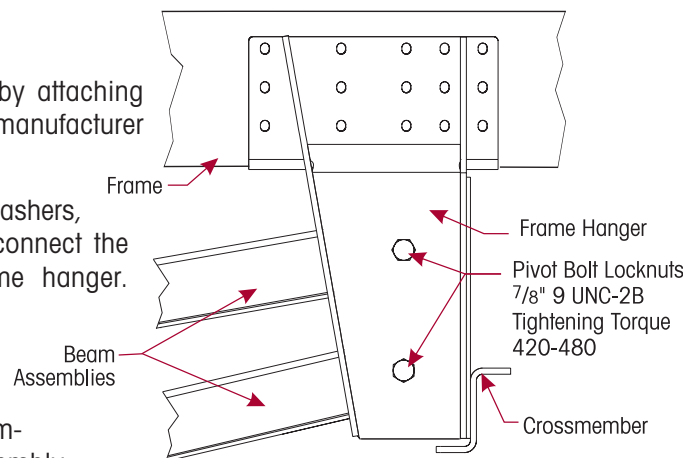

## BEAM ASSEMBLY AND WEAR PADS

### SERVICE HINT

Service beam assemblies on one side of vehicle at a time to maintain axle alignment.

### HENDRICKSON RECOMMENDS THE FOLLOWING WHEN SERVICING:

- One Wear Pad worn, that all Wear Pads, Pivot Bolt Liners, and fasteners on suspension be replaced.
- One Beam Bushing worn, that all Beam Bushings, Wear Pads, Pivot Bolt Liners, and fasteners on suspension be replaced.

### NOTE

On vehicles produced from 9/98-12/99, the upper and lower beam assemblies are NOT IDENTICAL.

- The upper beam assembly contains the fabricated beam and 2 rubber beam bushings.
- The lower beam assembly contains the fabricated beam w/ mounting flange for transverse leaf, 1 rubber bushing, 1 PTFE bushing, 1 inner metal, and 2 rubber seals.
- On vehicles produced after 1/00, the upper and lower beam assemblies ARE IDENTICAL.
- All beam assemblies contain the fabricated beam and 2 rubber beam bushings.

### DISASSEMBLY

1. Chock the wheels of the axle.
2. Raise the frame of the vehicle to remove the load from the suspension.
3. Verify that the air is removed from the system and support the frame with jack stands. (After determining the proper beam assembly on vehicle continue to Step 4.)



### WARNING

VEHICLE MUST BE FIRMLY SUPPORTED WITH JACK STANDS PRIOR TO SERVICING VEHICLE. FAILURE TO DO SO COULD RESULT IN PERSONAL INJURY OR PROPERTY DAMAGE.

### BEAM ASSEMBLY IN PRODUCTION 9/98 —12/99

Figure 5-2

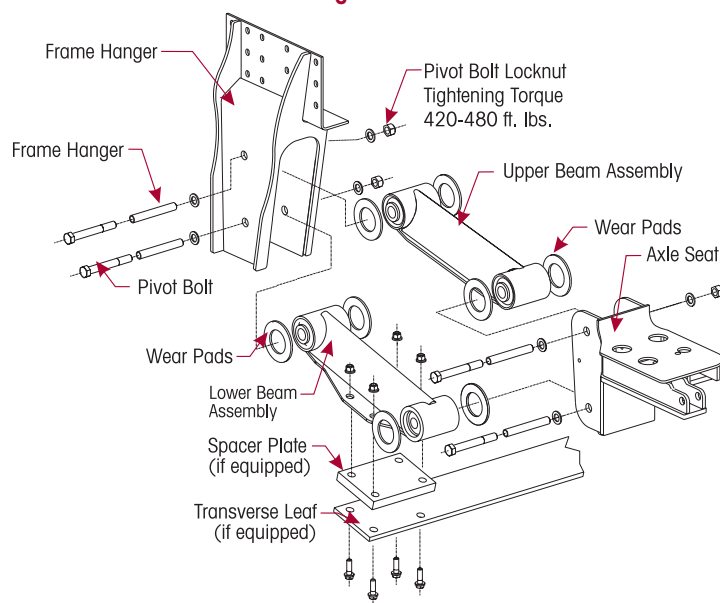

4. Detach the transverse leaf and spacer plates (if equipped) by removing the  $\frac{3}{4}$ " bolts, washers, and locknuts that connect the transverse leaf and spacer plates to the lower beam.
5. Loosen all the  $\frac{7}{8}$ " pivot bolt locknuts, DO NOT REMOVE. See Figure 5-2.
6. Remove the pivot bolts, washers, and locknuts that connect the **lower** beam assembly. **To avoid hitting crossmember**, remove the rear of beam assembly connected to the axle seat prior to the front of beam connected to the frame hanger.

7. Remove lower beam assembly and wear pads.
8. Remove the pivot bolts, washers, and locknuts that connect the **upper** beam assembly. **To avoid hitting crossmember**, remove rear of beam assembly connected to axle seat prior to front of beam connected to frame hanger.
9. Remove upper beam assembly and wear pads.

### ASSEMBLY

1. Attach wear pads and pivot bolt liners to beam assemblies.
2. Install upper beam assembly and attach fasteners. **DO NOT TIGHTEN** at this time.
3. Install lower beam assembly and attach fasteners. **DO NOT TIGHTEN** at this time.
4. Attach transverse leaf and spacers (if equipped). **DO NOT TIGHTEN** at this time.
5. After all four beam assemblies and transverse leaf and spacers (if equipped) are installed, tighten  $\frac{7}{8}$ " pivot bolt locknuts to 420-480 foot pounds torque.
6. Tighten transverse leaf  $\frac{3}{4}$ " locknuts to 260-320 foot pounds torque.
7. Remove jack stands and lower frame of vehicle.
8. Air up system.

### BEAM ASSEMBLY IN PRODUCTION 1/00 — CURRENT

**Figure 5-3**  
Upper and Lower Beam Assembly  
Current production

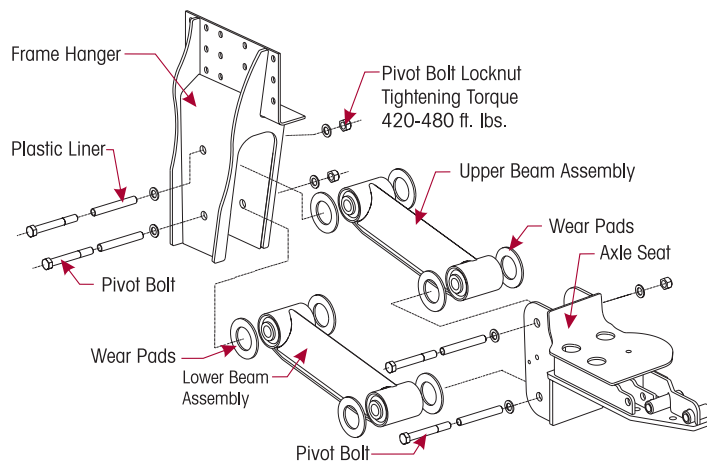

4. Loosen all pivot bolt locknuts, **DO NOT REMOVE** at this time.
5. Remove the pivot bolts, washers, and locknuts that connect the **lower** beam assembly. See Figure 5-3. **To avoid hitting crossmember**, remove rear of beam assembly connected to axle seat prior to front of beam connected to frame hanger.
6. Remove lower beam assembly and wear pads.
7. Remove the pivot bolts, washers, and locknuts that connect the **upper** beam assembly. **To avoid hitting crossmember**, remove rear of beam assembly connected to axle seat prior to front of beam connected to frame hanger.
8. Remove upper beam assembly and wear pads.

### ASSEMBLY

1. Attach wear pads and pivot bolt liners to beam assemblies.
2. Install upper beam assembly and attach fasteners. **DO NOT TIGHTEN** at this time.
3. Install lower beam assembly and attach fasteners. **DO NOT TIGHTEN** at this time.

4. After all four beam assemblies are installed tighten the  $\frac{7}{8}$ " pivot bolt locknuts to  420-480 foot pounds torque.
5. Remove the jack stands and lower the frame of vehicle.
6. Air up the system.

## BEAM ASSEMBLY BUSHINGS

### RUBBER BUSHINGS

Figure 5-4

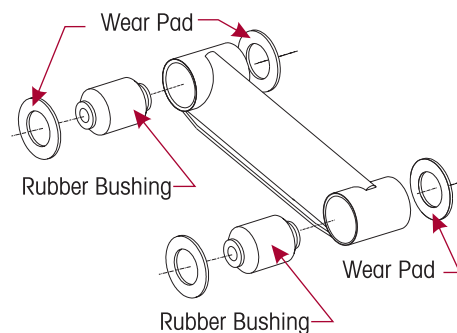

#### DISASSEMBLY

Use a vertical shop press with a capacity of at least 10 tons. A 5" long piece of 3.5" I.D. by .25" wall steel tubing receiving tool is required.

1. Support the beam assembly end hub centered on the receiving tool.
2. Press out the old bushing. Press directly on the bushing inner metal until the bushing clears the beam end hub. (These bushings are not cartridge type bushings. They do not have outer metals.) See Figure 5-4.
3. Clean and inspect the I.D. of beam end hub removing any nicks with emery cloth or rotary sander.

#### ASSEMBLY

1. Lubricate the I.D. of beam end hub and the new rubber bushings with vegetable base oil (cooking oil). DO NOT use petroleum or soap base lubricant.
2. Support the beam end hub centered on the receiving tool.
3. Press in the new bushings. Press directly on the inner metal of bushing. Bushings must be centered within the beam end hub. When pressing in the new bushings, overshoot desired final position by .18" and press the bushing again from opposite side to center the bushing within beam end hub.

## PTFE BUSHINGS

IN PRODUCTION 8/98 –12/99

**Figure 5-5**

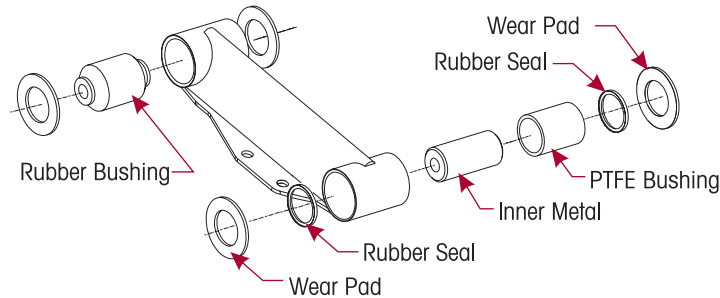

### DISASSEMBLY

Use a vertical shop press with a capacity of at least 10 tons. You will need: 5" long piece of 3.5" I. D. by .25" wall steel tubing receiving tool, along with a 2.87" O.D. by .50" wall steel tubing push out tool.

1. Remove the rubber seals.
2. Remove the inner metal. See Figure 5-5.
3. Support the beam assembly end hub centered on the receiving tool.
4. Place the push out tool on top of the bushing and press until bushing clears end of beam hub.
5. Clean and inspect the I.D. of the beam end hub, removing any nicks with emery cloth or rotary sander.

### ASSEMBLY

1. Lubricate the I.D. of beam end hub and O.D. of new bushing with a petroleum lubricant.
2. Support the beam end hub centered on the receiving tool.
3. Place the push out tool over end of bushing and align the bushing and tool in beam end hub.
4. Press in the new bushing. Bushing must be centered within the beam end hub.
5. Install the new inner metal. See Figure 5-5.

#### NOTE

Proper orientation of the new inner seal is important. The inner lip of the seal must face outboard.

6. Install new rubber seals.

#### CAUTION

FAILURE TO INSTALL SEAL IN PROPER ORIENTATION WILL CAUSE PREMATURE WEAR OF PTFE BUSHING.

## CROSSMEMBER

The crossmember is unlikely to require removal or replacement. In normal use it should function satisfactorily throughout the life of the vehicle. Replacement is only required when it has been bent due to hitting an unseen object. A bent crossmember could cause misalignment of the front suspension, and must be changed to eliminate abnormal tire wear.

**Figure 5-6**

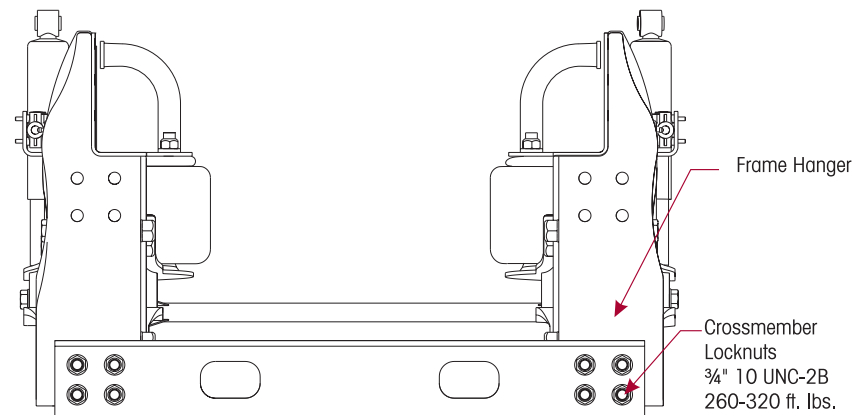

### DISASSEMBLY

1. Chock the wheels of the axle.
2. Raise the frame of the vehicle to remove the load from the suspension.



### WARNING

VEHICLE MUST BE FIRMLY SUPPORTED WITH JACK STANDS PRIOR TO SERVICING. FAILURE TO DO SO COULD RESULT IN PERSONAL INJURY OR PROPERTY DAMAGE.

3. Verify that the air is removed from the system.
4. Remove the beam assemblies, (see beam assembly Component Replacement Section of this publication).
5. Remove the  $\frac{3}{4}$ " bolts, washers, and locknuts that connect the crossmember to frame hangers. See Figure 5-6.

### ASSEMBLY

1. Install the new crossmember by attaching the  $\frac{3}{4}$ " bolts, washers, and locknuts. Tighten to  260-320 foot pounds torque.
2. Attach beam assemblies, (see beam assembly Component Replacement Section of this publication).
3. Remove the jack stands and lower the frame of vehicle.
4. Air up the system.

## TRANSVERSE LEAF (IF EQUIPPED)

IN PRODUCTION 9/98-12/99

See Figure 5-7

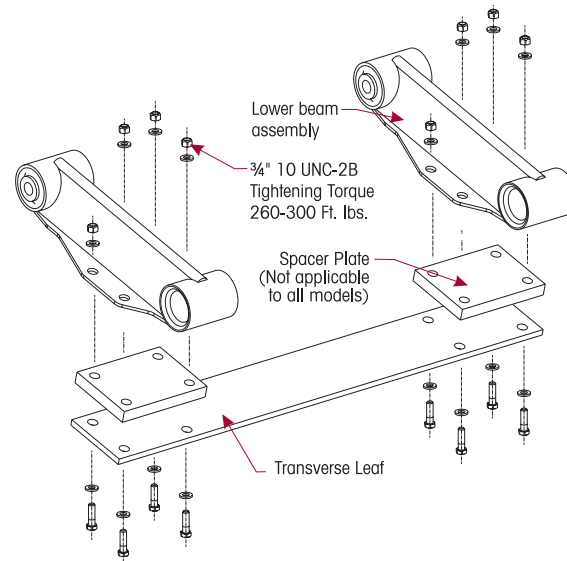

### DISASSEMBLY

1. Chock the wheels of the axle.
2. Raise the frame of vehicle to remove the load from the suspension.

### WARNING

THE VEHICLE MUST BE FIRMLY SUPPORTED WITH JACK STANDS PRIOR TO SERVICING. FAILURE TO DO SO COULD RESULT IN PERSONAL INJURY OR PROPERTY DAMAGE.

3. Verify that the air is removed from the system.
4. Remove the  $\frac{3}{4}$ " bolts, washers, and locknuts that connect the transverse leaf and spacer plates (if equipped) to the lower beam. See Figure 5-7.

### ASSEMBLY

1. Install the transverse leaf and spacers if equipped by attaching  $\frac{3}{4}$ " bolts, washers, and locknuts. Tighten the  $\frac{3}{4}$ " locknuts to  260-300 foot pounds torque.
2. Remove the jack stands and lower the frame of vehicle.
3. Air up the system.

## TRANSVERSE TORQUE ROD

### IN PRODUCTION 1/00–CURRENT

#### DISASSEMBLY

1. Chock the wheels of the axle.
2. Raise the frame of vehicle to remove the load from suspension.

#### WARNING

VEHICLE MUST BE FIRMLY SUPPORTED WITH JACK STANDS PRIOR TO SERVICING. FAILURE TO DO SO COULD RESULT IN PERSONAL INJURY OR PROPERTY DAMAGE.

3. Verify that the air is removed from the system.
4. Remove the  $\frac{5}{8}$ " bolts, washers, and locknuts that connect the transverse torque rod to the frame bracket and axle seat. See Figure 5-8.

Figure 5-8

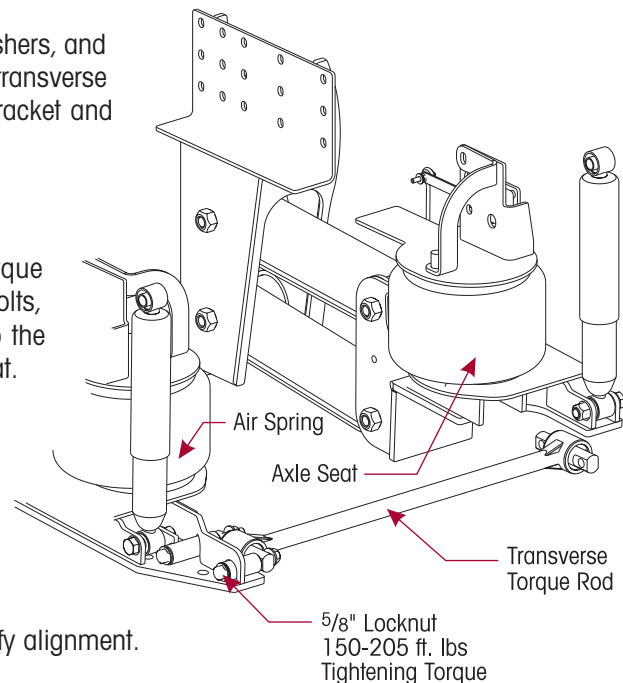

#### ASSEMBLY

1. Install the transverse torque rod by attaching the  $\frac{5}{8}$ " bolts, washers, and locknuts to the frame bracket and axle seat. Tighten  $\frac{5}{8}$ " locknuts to 150-205 foot pounds torque.
2. Remove the jack stands and lower the frame of the vehicle.
3. Air up the system and verify alignment.

## TRANSVERSE TORQUE ROD BUSHING REPLACEMENT

Remove torque rods from suspension as detailed in the Component Replacement Section of this publication.

#### CAUTION

DO NOT USE HEAT OR USE A CUTTING TORCH TO REMOVE THE BUSHINGS FROM THE TORQUE ROD. THE USE OF HEAT WILL ADVERSELY AFFECT THE STRENGTH OF THE TORQUE ROD.

You will need:

- A vertical press with a capacity of at least 10 tons.
  - A receiving tool (5" long, 2" inner diameter by  $\frac{1}{4}$ " wall steel tubing)
1. Support the torque rod end on the receiving tool with the end tube of torque rod centered on the tool. Be sure the torque rod is squarely supported on the press bed for safety.



2. Push directly on the bushing straddle mount bar pin until top of the bushing is level to the top of torque rod end tube. Press until the bushing clears the torque rod end tube.
3. Clean and inspect the inner diameter of the torque rod ends, removing any nicks with an emery cloth or a rotary sander (See Figure 5-9).
4. Lubricate the inner diameter of the torque rod ends and the new rubber bushings with a vegetable base oil (cooking oil), see Figure 5-10. DO NOT use a petroleum or soap base lubricant.
5. Press in the new bushings. Support the torque rod end on the receiving tool with the end tube of torque rod centered on the receiving tool. The straddle mount bar pin bushings must have the mounting flats positioned at zero degrees to shank of the torque rod.
6. Press directly on the straddle mount bar pin of bushing. The rubber bushings of the bar pin must be centered within the torque rod end tubes.
7. When pressing in the new bushings, overshoot the desired final position by approximately  $\frac{3}{16}$ ", see Figure 5-11.
8. Press the bushing again from opposite side to center the bar pin within the torque rod end, see Figure 5-12.

**Figure 5-9****Figure 5-10****Figure 5-11****Figure 5-12**

## AIR SPRING

### DISASSEMBLY

1. Chock the wheels of the axle.
2. Raise the frame of the vehicle to remove load from the suspension.



### WARNING

VEHICLE MUST BE FIRMLY SUPPORTED WITH JACK STANDS PRIOR TO SERVICING. FAILURE TO DO SO COULD RESULT IN PERSONAL INJURY OR PROPERTY DAMAGE.

3. Verify that the air is removed from the system.
4. Remove the locknut and washer that connect the air spring to the axle seat.
5. Remove the air line from the air spring.
6. Remove the brass fittings from the air spring.
7. Remove the locknuts and washers that connect the air spring to the upper air spring hanger and the reinforcement bracket. See Figure 5-13.
8. Remove the air spring.

### ASSEMBLY

1. Install air spring in upper air spring hanger and reinforcement bracket by inserting studs into appropriate holes and attach washers and locknuts.
2. Install the air spring in axle seat by inserting the stud into the appropriate hole and attach washer and locknut.
3. Tighten the  $\frac{1}{2}$ " locknuts to 20-30 foot pounds torque. Tighten the  $\frac{3}{4}$ " locknut to 40-50 foot pounds torque. See Figure 5-13.
4. Install the brass fitting in the air spring using a Teflon thread seal.
5. Connect the air line to the air spring.
6. Remove the jack stands and lower the frame of vehicle.
7. Air up the system.

**Figure 5-13**

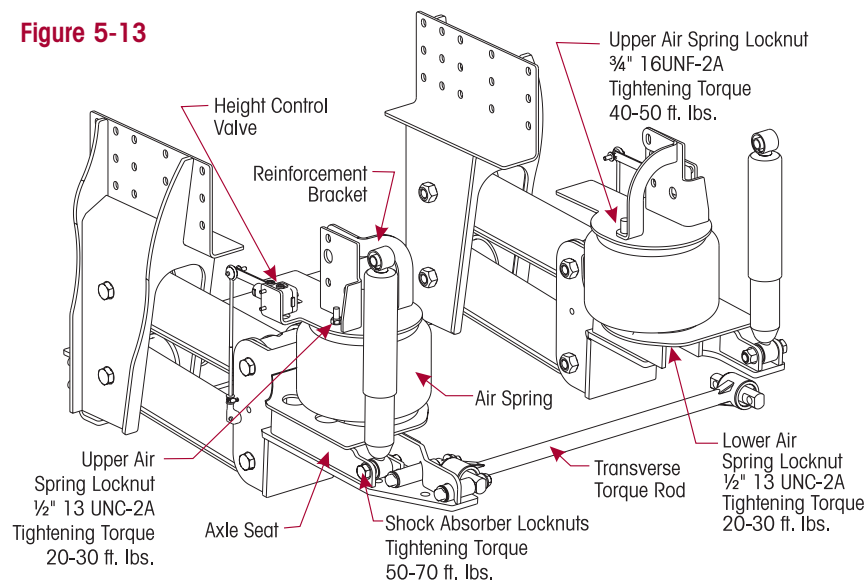

## AIR SPRING FRAME HANGER AND REINFORCEMENT BRACKET

The air spring frame hanger and reinforcement bracket are unlikely to require removal or replacement. In normal use they should function satisfactorily throughout the life of the vehicle. Replacement is only required when they have been damaged.

### DISASSEMBLY

1. Chock the wheels of the axle.
2. Raise the frame of vehicle to remove the load from the suspension.



### WARNING

VEHICLE MUST BE FIRMLY SUPPORTED WITH JACK STANDS PRIOR TO SERVICING. FAILURE TO DO SO COULD RESULT IN PERSONAL INJURY OR PROPERTY DAMAGE.

3. Verify that the air is removed from the system.
4. Remove the air line from the air spring.
5. Remove the brass fittings from the air spring.
6. Remove the locknuts and washers that connect the air spring to the air spring hanger and the reinforcement bracket. See Figure 5-13.
7. Lower the air spring out of air spring hanger and reinforcement bracket.
8. Remove the fasteners that attach the air spring hanger and reinforcement bracket to vehicle.
9. Remove the air spring hanger and the reinforcement bracket.

### ASSEMBLY

1. Install the air spring hanger and the reinforcement bracket by attaching frame fasteners per vehicle manufacturer specification.
2. Install the air spring in the air spring hanger and reinforcement bracket by inserting the studs into the appropriate holes and attach washers and locknuts. Tighten the 1/2" locknut to 20-30 foot pounds torque. Tighten the 3/4" locknut to 40-50 foot pounds torque. See Figure 5-13.
3. Install the brass fitting in the air spring using a Teflon thread seal.
4. Connect the air line to the air spring.
5. Remove the jack stands and lower the frame of vehicle.
6. Air up the system.

## SHOCK ABSORBER

Original equipment shock absorbers are 1 $\frac{3}{4}$ " diameter bore.

**Figure 5-14**

### DISASSEMBLY

1. Remove the locknut and washers that connect the shock absorber to the frame hanger.
2. Remove the bolt, washers, and locknut that connect the shock absorber to the axle seat.
3. Remove the shock absorber.

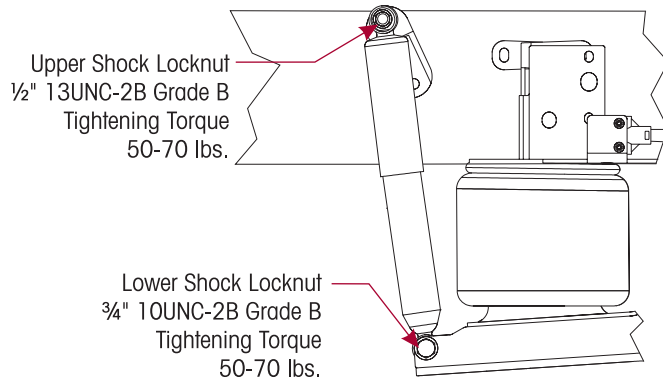

### ASSEMBLY

1. Install the shock absorber to the frame bracket stud by attaching the washers and locknut. Washers must be installed on each side of the shock bushing.
2. Install the shock absorber to the axle seat by attaching the bolt, washers, and locknut. See Figure 5-14.
3. Tighten the shock fasteners to  50-70 foot pounds torque.

## AXLE SEAT

The axle seat is unlikely to require removal or replacement. In normal use it should function satisfactorily throughout the life of the vehicle. Replacement is only required when the axle seat is damaged.

### DISASSEMBLY

1. Chock the wheels of axle.
2. Raise the frame of vehicle to remove load from suspension.

### WARNING

VEHICLE MUST BE FIRMLY SUPPORTED WITH JACK STANDS PRIOR TO SERVICING. FAILURE TO DO SO COULD RESULT IN PERSONAL INJURY OR PROPERTY DAMAGE.

3. Verify that air is removed from the system.
4. Remove the beam assemblies, (see beam assembly in the Component Replacement Section of this publication).
5. Remove the  $\frac{5}{16}$ " washer and locknut that attach the ride height control valve extension rod to the axle seat. See Figure 5-15.
6. Remove the  $\frac{1}{2}$ " washer and locknut, that attach the air spring to the axle seat, and raise the air spring out of the axle seat.

7. Remove the  $\frac{3}{4}$ " bolt, washers, and locknut, that attach the shock absorber to axle seat, and raise the shock absorber out of the axle seat.
8. Remove the fasteners that attach the axle seat to the axle.
9. Remove the axle seat.

**ASSEMBLY**

1. Install the axle seat by attaching the fasteners per the vehicle manufacturer specifications.
2. Install the beam assemblies, (see beam assembly in the Component Replacement Section of this publication).
3. Install air spring in axle seat by attaching  $\frac{1}{2}$ " washer and locknut to stud. Tighten  $\frac{1}{2}$ " locknuts to 20-30 foot pounds torque.
4. Install shock absorber in axle seat by attaching  $\frac{3}{4}$ " bolt, washers, and locknut. Tighten to 50-70 foot pounds torque. See Figure 5-15
5. Install ride height control valve extension rod in axle seat by attaching  $\frac{5}{16}$ " washer and locknut. Tighten  $\frac{5}{16}$ " locknuts to 100-150 inch pounds torque, see Figure 5-16.
6. Remove the jack stands and lower the frame of vehicle.
7. Air up the system.
8. Verify that the suspension is at the proper ride height setting, see ride height setting in the Preventive Maintenance Section of this publication.

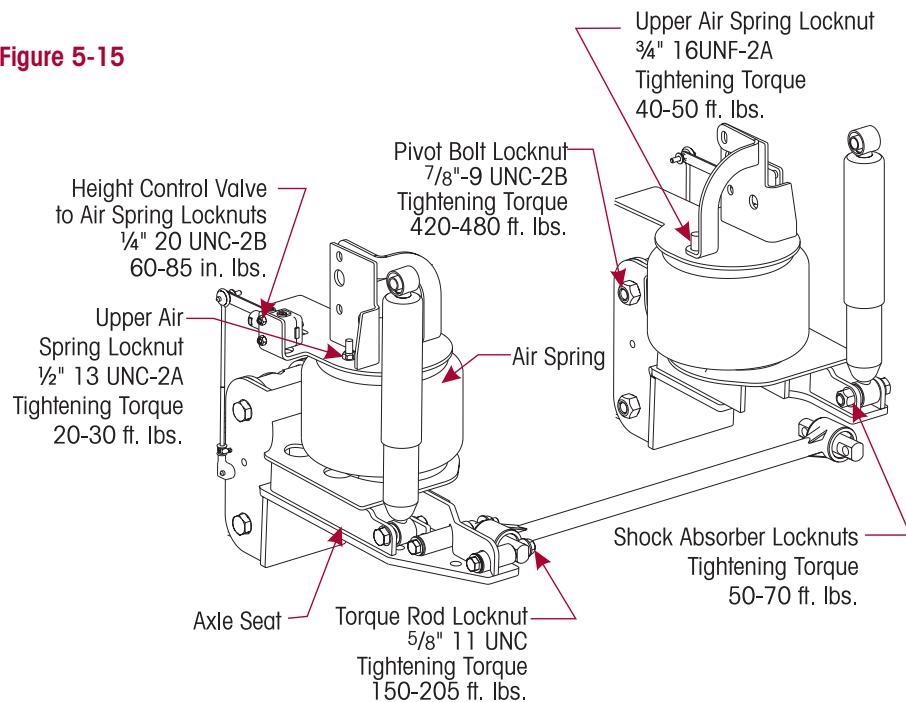
**Figure 5-15**

## RIDE HEIGHT CONTROL VALVE

Figure 5-16

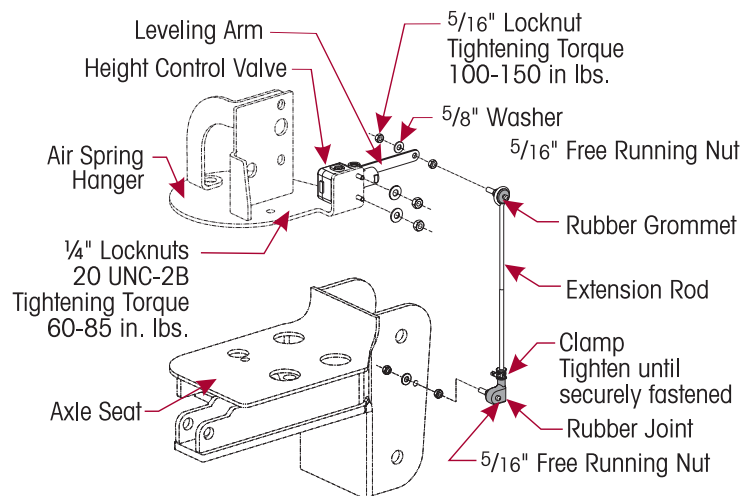

### DISASSEMBLY

1. Chock wheels of the axle.
2. Raise the frame of vehicle to remove the load from the suspension.



### WARNING

VEHICLE MUST BE FIRMLY SUPPORTED WITH JACK STANDS PRIOR TO SERVICING. FAILURE TO DO SO COULD RESULT IN PERSONAL INJURY OR PROPERTY DAMAGE.

3. Verify that the air is removed from the system.
4. Remove the  $\frac{5}{16}$ " washers and locknuts that attach the extension rod to the height control valve arm. See Figure 5-16.
5. Remove the air lines from the height control valve.
6. Remove the brass fittings from the height control valve.
7. Remove the  $\frac{1}{4}$ " washers and locknuts that attach the height control valve to the air spring frame hanger.
8. Remove the height control valve.

### ASSEMBLY

1. Install the ride height control valve to air spring frame hanger by attaching the  $\frac{1}{4}$ " washers and locknuts. Tighten  $\frac{1}{4}$ " locknuts to 60-85 inch pounds torque. See Figure 5-16.
2. Install brass fittings into height control valve using Teflon thread seal.
3. Install air lines to ride height control valve.
4. Install the extension rod to the ride height control valve arm by attaching the  $\frac{5}{16}$ " washers and locknut. Tighten  $\frac{5}{16}$ " locknuts to 100-150 inch pounds torque.
5. Remove the jack stands and lower the frame of vehicle.
6. Air up the system.
7. Verify that the suspension is at the proper ride height setting, (see ride height setting in the Preventive Maintenance Section of this publication).



# SECTION 6 PARASTEER AIR PLUMBING DIAGRAM

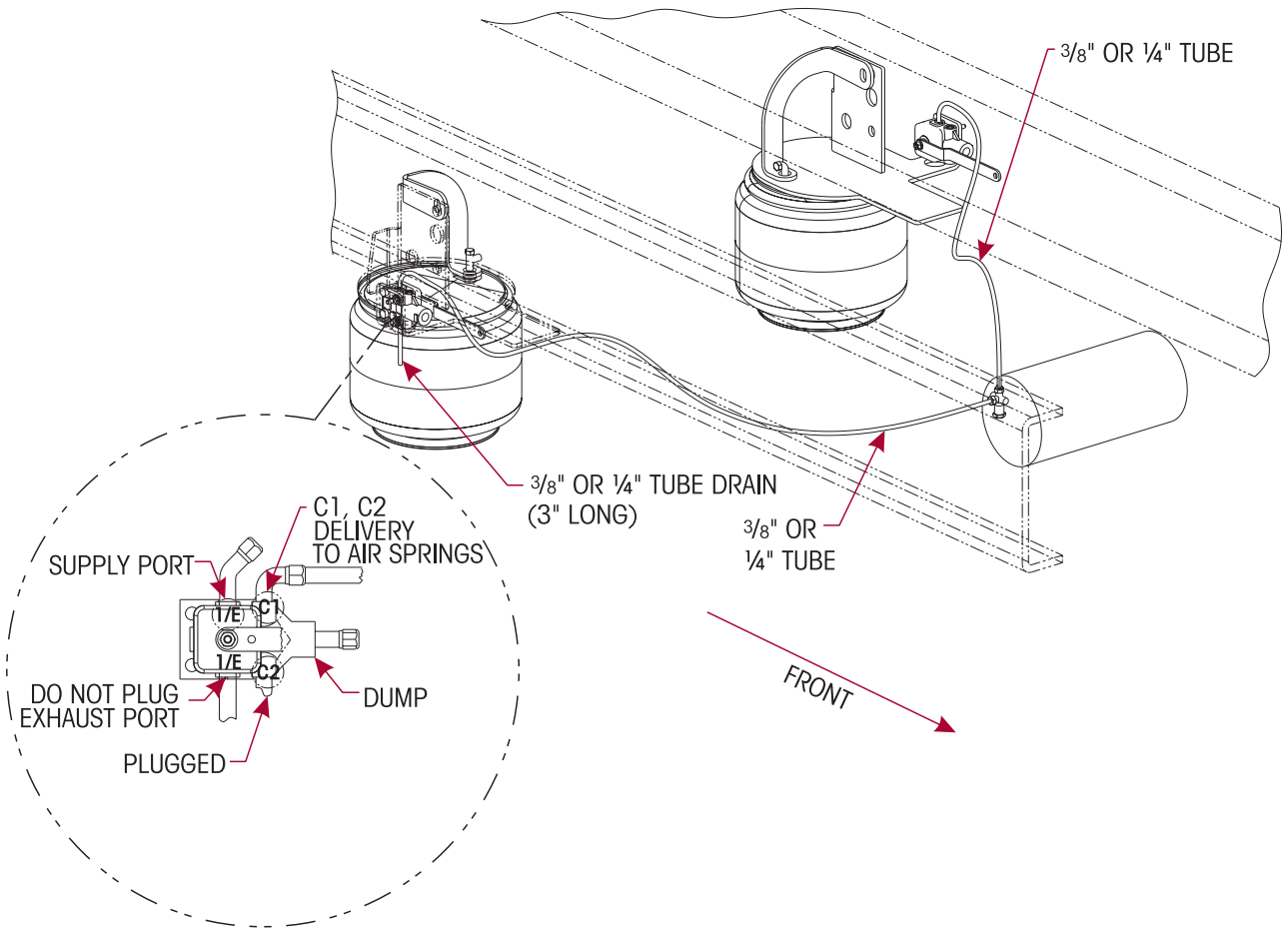

# SECTION 7

## Tightening Torque Specification Chart

Description		Part No.	Hendrickson Thread/Grade	Torque Ft./Lbs.
Air Spring Hanger and Frame Hanger to Vehicle Frame Bolts, Nuts, & Washers		None	Furnished & Installed by Truck Manufacturer	*
Pivot Bolt Locknut		50106-000	7/8"-9 UNC-2B Grade C	420-480
Air Spring Bolt Kit	Upper	17700-031	3/4"-16 UNF-2A Grade B	40-50
	Upper	17700-010	1/2"-13 UNC-2A Grade B	20-30
	Lower	17700-010	1/2"-13 UNC-2A Grade B	20-30
Crossmember to Frame Hanger Locknut		49842-000	3/4"-10 UNC-2B Grade C	260-320
Shock Absorber & Stabilizer Shock (if equipped)	Upper	49846-000	1/2"-13UNC-2B Grade C	50-70
	Lower	49842-000	3/4"-10 UNC-2B Grade C	50-70
Transverse Leaf to Lower Beam Assembly Locknut (if equipped)		49842-000	3/4"-10 UNC-2B Grade C	260-320
Height Control Valve to Air Spring Hanger		49983-000	1/4"-20 UNC-2B Grade B	60-85 IN/LBS.
Extension Arm Jam Nut		17491-019	5/16"-24 UNF-2B Grade 5	100-150 IN/LBS.
Extension Arm Locknut		59016-000	5/16"-18 UNC-2B Grade C	100-150 IN/LBS.
Torque Rod Locknut		47764-000	5/8"-11 UNC-Grade B	150-205
Extension Rod Clamp		58969-000		Securely Fastened

### IMPORTANT NOTE

\* Torque values listed above apply only if Hendrickson supplied fasteners are used. If non-Hendrickson fasteners are used, follow the torque specifications listed in the vehicle manufacturer's service manual.

