

HAULMAAX® EX / COMPOSILITE® EXS Suspension System Solutions

In a market that requires durable, lightweight suspensions, **HAULMAAX® EX** heavy-duty vocational suspensions and **COMPOSILITE® EXS** steerable lift axles deliver outstanding performance and reliability.

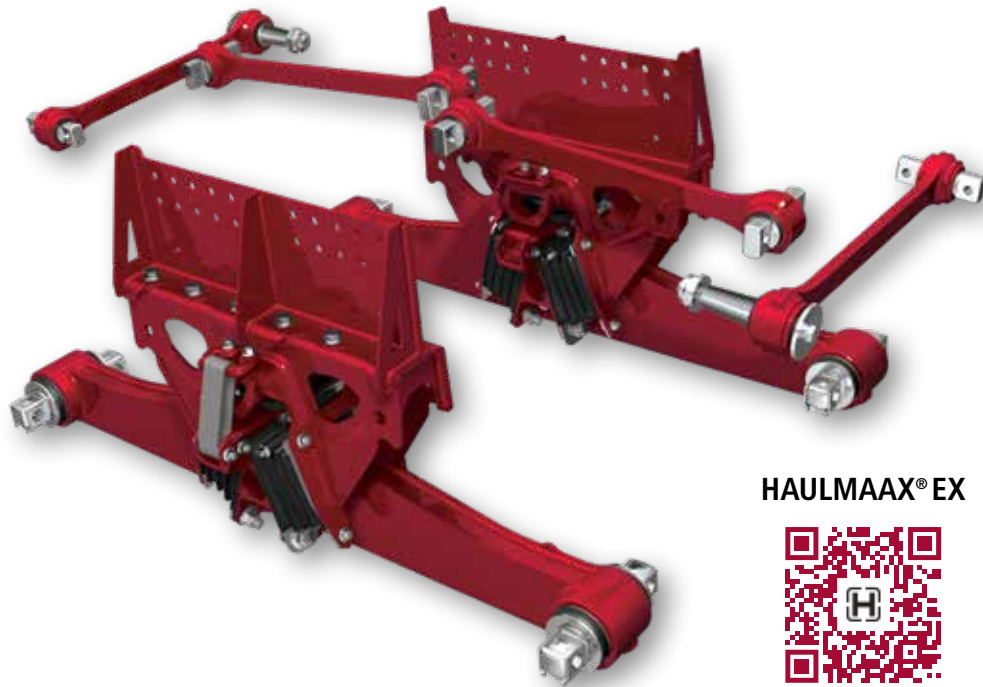

HAULMAAX® EX



COMPOSILITE® EXS



To learn more about **HAULMAAX EX** and **COMPOSILITE EXS**, visit www.hendrickson-intl.com

 **HENDRICKSON**
The World Rides On Us®



HAULMAAX[®] EX

Heavy-Duty Rear Rubber Suspension

MAAXimize Payload and Durability

Suspension geometry is optimized to provide better job-site rating, increased capacity ranges and improved durability. Utilizing industry leading validation techniques, high-strength materials, and advanced manufacturing methods, HAULMAAX[®] EX meets increasing rigorous application demands by delivering the reliability and quality you've come to expect from Hendrickson, the leader in suspension technology.

TRAAX ROD[®] – Torque Rods

- Fabricated heavy-duty torque rods provide greater durability over conventional rods
- Enhance handling during cornering by controlling lateral forces to maintain axle position

Saddle and Frame Bracket

- Lightweight, modular design simplifies installation

Progressive Load Spring

- Increases stiffness as the load increases, providing a unique balance of empty ride quality and loaded stability
- Provides long service life and easy replacement for reduced down time
- Eliminates shim adjustments for reduced maintenance

Premium Rubber Bolster Springs

- The unique design works with the Progressive Load Spring to deliver exceptional empty ride quality and loaded stability
- Optimized angle allows bolster springs to carry the majority of the payload and still react to braking and accelerating forces with minimal displacement

Dual Strap Kit

- Provides additional bolster spring protection
- Required on vehicles equipped with outriggers
- Available as production or aftermarket options

Bar Pin End Connection

- Rugged axle connection extends bushing life and allows easy axle alignment and serviceability

Equalizing Beam

- Formed and robotically-welded beam provides a narrow profile for weight savings
- Distributes load equally between both axles for improved maneuverability, stability and handling
- Lowers the center of gravity to increase stability
- Narrow, offset beam allows for better packaging and increased tire clearance
- Center bushing eliminated for reduced maintenance

Shock Absorbers

- Provide additional driver comfort
- Required for tractor and logging applications
- Available as production or aftermarket options

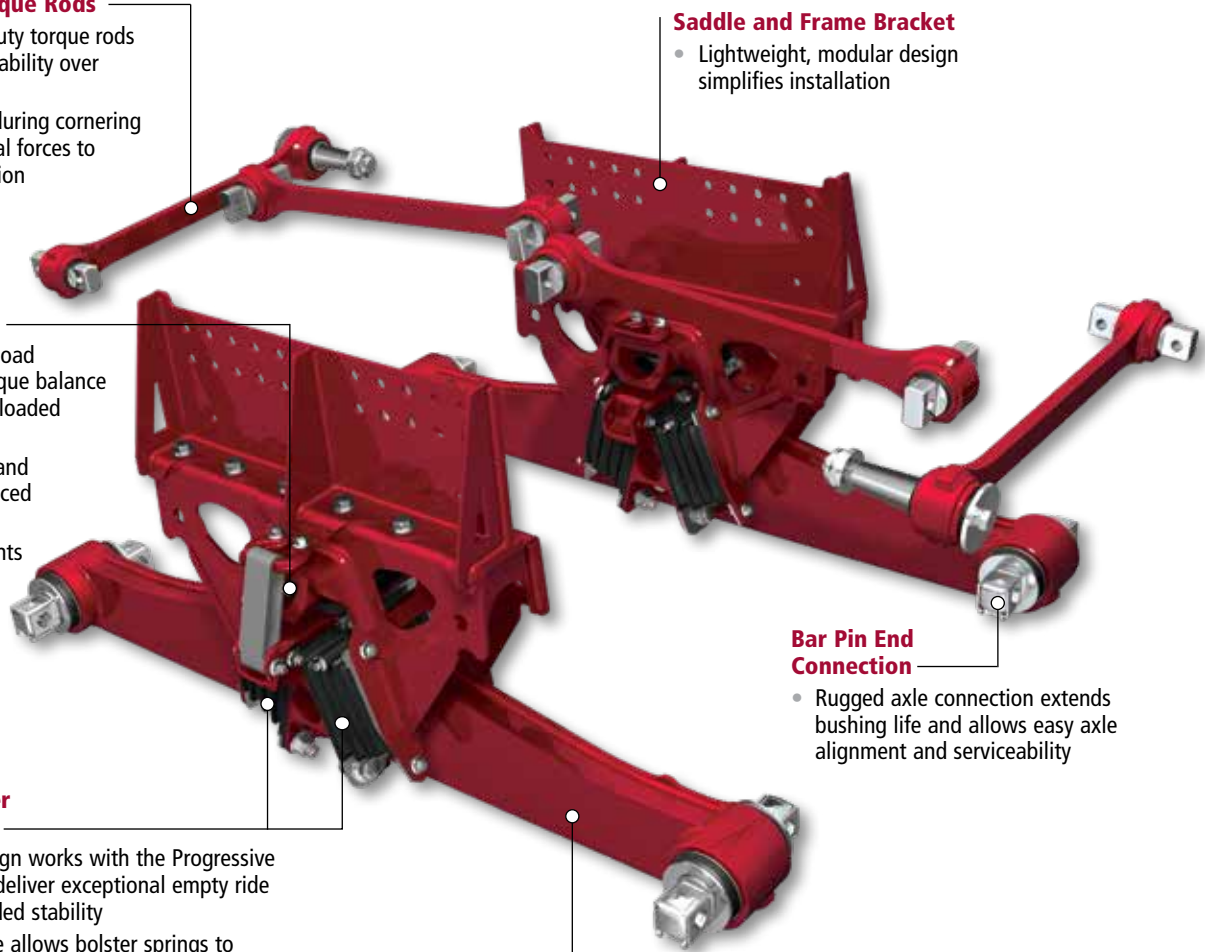

H COMPOSILITE® EXS Lightweight Steerable Lift Axle Suspension System

Hendrickson offers the COMPOSILITE® series of lift axles for steerable applications to deliver the advantages haulers have come to expect from Hendrickson. Innovative features and benefits provide enhanced reliability and cost-effective operation. The EXS product family offers a full range of capacities from 8,000 to 20,000 pounds.

The EXS13K is rated at 13,500 pounds, our most popular capacity offering, with a minimized package space of 22.1 inches. Hendrickson has implemented an inset lower beam design to provide increased built-in lateral stiffness. The axle design provides a bolt-on seat for an easier, less costly axle change. Zero-torsion rubber bushings enhance performance and reduce replacement cycle time.

EXS13K

Inset Lower Beams

- Optimized lateral stiffness
- Eliminate the need for V-rods



Weld-Free Hanger Design

- No welding on front side rail hangers minimizes stress risers
- Flat hanger design allows for flexibility of bolt hole patterns

Zero-Torsion Rubber Bushings

- Provide increased durability and bushing life
- Improve overall cost of ownership with less downtime

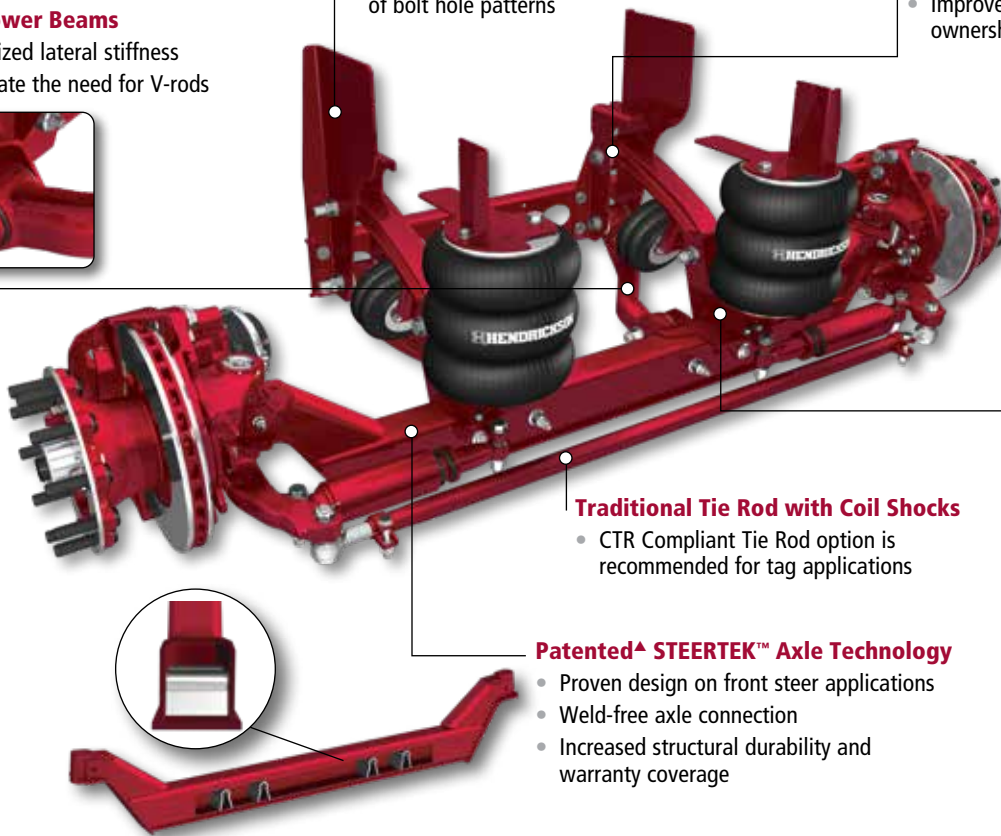

Bolt-On Axle Seats

- Easier serviceability for ride height changes or altering tire sizes
- Less costly repairs — change seats, not axle
- Lower cost of ownership

Traditional Tie Rod with Coil Shocks

- CTR Compliant Tie Rod option is recommended for tag applications

Patented[▲] STEERTEK™ Axle Technology

- Proven design on front steer applications
- Weld-free axle connection
- Increased structural durability and warranty coverage



EXS13K Specifications

Capacity:	Up to 13,500 pounds
Weight:	922 pounds
Travel:	13 inches
Lift:	10 inches
Wheel Cut:	31 degrees
Packaging Space:	22.1 inches

COMPOSILITE EXS Steerable Turning Angle

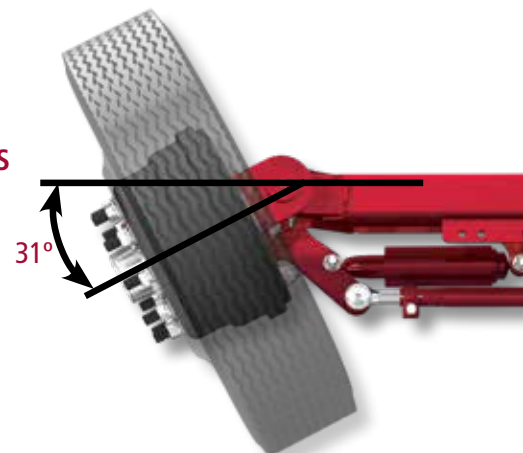

HAULMAAX® EX Heavy-Duty Rear Rubber Suspension Specifications

Model	HMX EX 400	HMX EX 460	HMX EX 520
Installed Weight ¹ (lbs.)	855	864	958 ⁸
Suspension Rating (lbs.)	40,000	46,000	52,000
GVW Approval ² (lbs.)	83,000	88,000	93,000
GCW Approval (lbs.)	160,000	190,000	245,000
Job-Site Travel Rating ³ (lbs.)	60,000	70,000	75,000
Diagonal Articulation ⁴ (in.)	17	17	17
Lift Axles	Approved	Approved	Approved
Ride Heights ⁵ (in.)	9.5 – 13.25	9.5 – 13.25	9.5 – 13.25
Axle Spacing ⁶ (in.)	52 and 54	52 – 72.5	52, 54, 60
Shock Absorber Applications ⁷	Tractors, Logging	Tractors, Logging	Tractors, Logging

Hendrickson approves the use of HAULMAAX® EX in the following vocational truck applications: dump, concrete mixer, refuse, logging, crane / boom, platform and fire / rescue.

1. Installed weight includes complete suspension, torque rods, axle brackets and frame brackets; add 31 lbs. for shock absorbers.
2. Contact Hendrickson or vehicle manufacturer for applications that may exceed GVW / GCW approval ratings.
3. Job-site travel rating — operators using vehicles equipped with liftable pusher or tag axles must not exceed published ratings. Job-site ratings are limited to no more than five percent of vehicle operation at speeds not to exceed five mph. Liftable pusher or tag axles should only be raised (or unloaded) to improve vehicle maneuverability in job-site applications or when vehicle is empty. Job-site travel ratings are consistent with published axle manufacturer's limitations. Axle and suspension job-site travel specifications must not be exceeded.
4. Suspension articulation may exceed vehicle's capability and may be limited by vehicle manufacturer; vehicle manufacturer installed axle stops may restrict suspension's articulation.
5. HAULMAAX EX ride height measurements are taken from the centerline of the axle to the bottom of the truck frame.
6. Contact Hendrickson for availability of beam lengths.
7. Shock absorbers are required in tractor and logging applications. Ride and traction may be improved in other applications with shock absorbers. Ride performance can be subjective and may be dependent on many factors beyond the suspension design such as cab suspension, road conditions, body / auxiliary equipment, frame specifications, etc. Contact Hendrickson or your truck manufacturer / dealer for further information.
8. HMX EX 520 installed weight includes complete suspension, double rebound straps, longitudinal torque rods, Hendrickson TRAAX ROD® transverse torque rods, axle brackets and frame brackets; add 31 lbs. for shock absorbers.



Optional shock absorbers

COMPOSILITE® EXS Steerable Lift Axle Specifications

MODEL	SUSPENSION RATING (lbs.)	INSTALLED WEIGHT (lbs.)	RIDE HEIGHTS (inches)
EXS08	8,000	831	8.5 - 20.5
EXS10	10,000	872	8.5 - 20.5
EXS13	13,500	926	8.5 - 20.5
EXS20	20,000	1,470	8.5 - 20.5
EXS13 (RO)	Roll-Off 13,500	926	8.5 - 20.5
EXS20 (RO)	Roll-Off 20,000	1,393	8.5 - 20.5

Worldwide, OEMs, Fleets and Owner-Operators put their trust in Hendrickson for innovative truck airlift suspension technology. For decades, Hendrickson lift axle suspension systems have proven their ability to handle the rigors of severe truck applications. The COMPOSILITE® EXS lift axle platform brings numerous features to meet hauling challenges. Drivers have the choice of various ride heights for light- and extreme-duty applications. The option of single- or dual-tire accommodation is also available to optimize maximum capacity range and turning radius / wheel cut.

These products are covered by at least one or more U.S. and / or foreign patents and / or pending U.S. and / or foreign patent applications. See Hendrickson for details.

Actual product performance may vary depending upon vehicle configuration, operation, service and other factors.

All applications must comply with applicable Hendrickson specifications and must be approved by the respective vehicle manufacturer with the vehicle in its original, as-built configuration.

Contact Hendrickson for additional details regarding specifications, applications, capacities, and operation, service and maintenance instructions.

Call Hendrickson at **630.910.2800** or **855.RIDERED (743.3733)** for additional information.



www.hendrickson-intl.com

45745-512 Rev E 05-23

© 2020-2023 Hendrickson USA, L.L.C. All Rights Reserved. All trademarks shown are owned by Hendrickson USA, L.L.C., or one of its affiliates, in one or more countries.

Information contained in this literature was accurate at the time of publication. Product changes may have been made after the copyright date that are not reflected.

TRUCK COMMERCIAL VEHICLE SYSTEMS

800 South Frontage Road
Woodridge, IL 60517-4904 USA
855.RIDERED (743.3733)
630.910.2800 • Fax 630.910.2899

SPECIALTY PRODUCTS - AUXILIARY AXLE SYSTEMS

277 North High Street
Hebron, OH 43025 USA
800.660.2829
740.929.5600 • Fax 740.929.5601