

- MAAximize payload
- MAAximize performance
- MAAximize durability

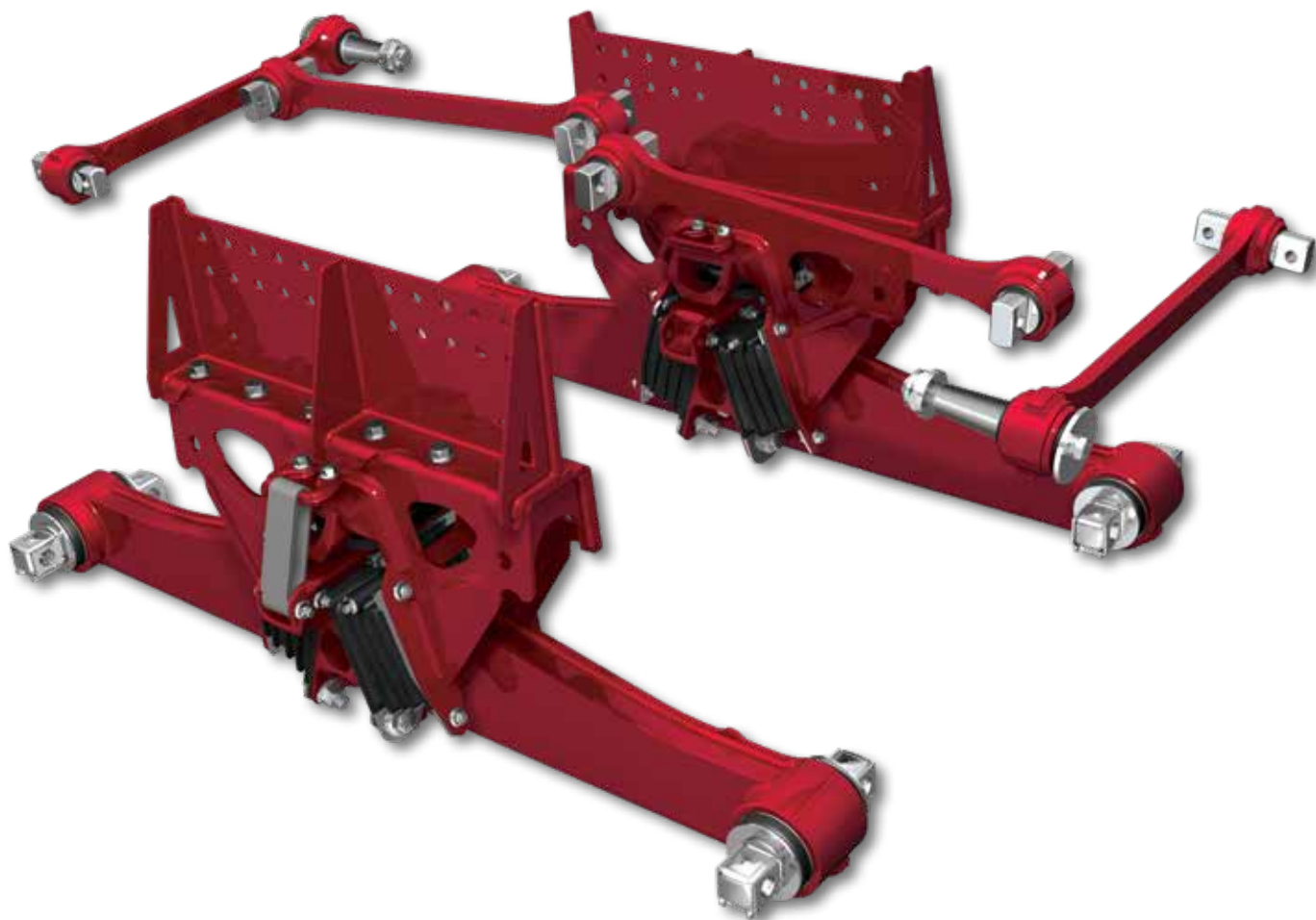

To learn more about HAULMAAX EX,
call 855.743.3733 or visit
www.hendrickson-intl.com



HAULMAAX[®] EX

Heavy-Duty Lightweight Rear Rubber Suspension System

MAAXimize Payload and Durability

Suspension geometry is optimized to provide better jobsite travel rating, increased capacity ranges and improved durability. Utilizing industry-leading validation techniques, high-strength materials and advanced manufacturing methods, HAULMAAX[®] EX meets increasingly rigorous application demands by delivering the reliability and quality you've come to expect from Hendrickson, a leader in suspension technology.

Hendrickson TRAAX ROD[®] Torque Rods

- Fabricated heavy-duty torque rods provide greater durability over conventional rods
- Enhance handling during cornering by controlling lateral forces to maintain axle position
- Required in transverse torque rod position
- Optional in longitudinal torque rod position

Hendrickson Longitudinal Torque Rods

- Longitudinal torque rods engineered to optimize resistance to wind up during acceleration and braking

Saddle and Frame Bracket

- Lightweight, modular design simplifies installation

Progressive Load Spring

- Increases stiffness as the load increases, providing a unique balance of empty ride quality and loaded stability
- Provides long service life and easy replacement for reduced downtime
- Eliminates shim adjustments for lower maintenance

Premium Rubber Bolster Springs

- The unique design works with the Progressive Load Spring to deliver exceptional empty ride quality and loaded stability
- Optimized angle allows bolster springs to carry the majority of the payload and still react to braking and accelerating forces with minimal displacement

Dual Rebound Straps

- Provides additional bolster spring protection
- Required on vehicles equipped with outriggers
- Standard for 52K suspensions
- Available as production or aftermarket options

Bar Pin End Connection

- Rugged axle connection extends bushing life and allows easy axle alignment and serviceability

Equalizing Beam

- Formed and robotically-welded beam provides a narrow profile for weight savings
- Distributes load equally between both axles for improved maneuverability, stability and handling
- Lowers the center of gravity to increase stability
- Narrow offset beam allows for better packaging and increased tire clearance
- Center bushing eliminated for reduced maintenance

Shock Absorbers

- Provide additional driver comfort
- Required for tractor and logging applications
- Available as production or aftermarket options



MAAXimize Performance

HAULMAAX® EX features a unique spring design that balances empty-ride quality and loaded stability. Angled bolster springs and a unique Progressive Load Spring (PLS) provide exceptional stability for demanding applications such as refuse, concrete mixers and dumps.

How it Works:



**Lightweight Body
(unloaded)**

- In the empty condition, the suspension rides primarily on the angled rubber bolster springs, which help absorb road inputs and fore / aft shock for outstanding ride quality



**Heavy Body
(e.g. mixer - unloaded)**

- In the empty condition when using a heavy body, the progressive load spring will be compressed and no gap will be visible



Loaded

- As payload is added and the vehicle's weight increases, the progressive load spring compresses and increases in stiffness to provide additional stability



At Site Rating

- Once fully engaged, the progressive load spring is supported by an integrated jounce stop; protecting the rubber components from over-compression

After the first 2 to 6 months of use, the spring system may exhibit a reduced PLS gap or none at all, which is normal, even with rubber components in good condition.

MAAXimize Uptime

Help reduce life cycle costs and increase the uptime of your vehicle:

- Superior ride reduces road shock and vibration to the vehicle to promote longer service life and fewer repairs to the cab, chassis and body equipment
- Integrated jounce stop protects rubber components from compressing beyond their operating range, extending durability and service life
- No lubrication requirements
- Fewer bushings to maintain — center bushing eliminated
- Rubber springs provide long service life and easy replacement
- Bar pin end bushings help extend service life and provide alignment capability for longer tire life
- Hendrickson torque rod bushings provide enhanced performance over conventional bushings
- Hendrickson parts and service available at thousands of locations worldwide
- Comprehensive technical support and training

MAAXimize Mobility and Traction

HAULMAAX EX provides the versatility for demanding jobsite conditions. When loaded, HAULMAAX EX allows up to 17 inches* of diagonal wheel articulation to keep load on all drive wheels. Unloaded articulation varies with vehicle configuration and empty body weight. In addition, unlike other walking beam suspensions, the innovative HAULMAAX EX design eliminates fixed center bushing pivot points to reduce wheel hop.

* Suspension articulation may exceed vehicle's capability and may be limited by vehicle manufacturer; vehicle manufacturer installed axle stops may restrict suspension's articulation.



HAULMAAX® EX Specifications

	HAULMAAX EX 400	HAULMAAX EX 460	HAULMAAX EX 520
Installed Weight¹ (lbs.)	855	864	958 ⁸
Suspension Rating (lbs.)	40,000	46,000	52,000
GVW Approval² (lbs.)	83,000	88,000	93,000
GCW Approval (lbs.)	160,000	190,000	245,000
Jobsite Travel Rating³ (lbs.)	60,000	70,000	75,000
Diagonal Articulation⁴ (in.)	17	17	17
Lift Axles	Approved	Approved	Approved
Ride Heights⁵ (in.)	9.5 – 13.25	9.5 – 13.25	9.5 – 13.25
Axle Spacing⁶ (in.)	52 and 54	52 – 72.5	52 – 60
Shock Absorber Applications⁷	Tractors, Logging	Tractors, Logging	Tractors, Logging

Hendrickson approves the use of HAULMAAX® EX in the following vocational truck applications: dump, concrete mixer, refuse, logging, crane / boom, platform and fire / rescue.

1. Installed weight includes complete suspension, torque rods, axle brackets and frame brackets; add 31 lbs. for shock absorbers.
2. Contact Hendrickson for applications that may exceed GVW approval ratings.
3. Jobsite travel rating — operators using vehicles equipped with liftable pusher or tag axles must not exceed published ratings. Jobsite ratings are limited to no more than five percent of vehicle operation at speeds not to exceed five miles per hour. Liftable pusher or tag axles should only be raised (or unloaded) to improve vehicle maneuverability in jobsite applications or when vehicle is empty. Jobsite travel ratings are consistent with published axle manufacturer's limitations. Axle and suspension jobsite travel specifications must not be exceeded.
4. Suspension articulation may exceed vehicle's capability and may be limited by vehicle manufacturer; vehicle manufacturer installed axle stops may restrict suspension's articulation.
5. HAULMAAX EX ride height measurements are taken from the centerline of the axle to the bottom of the truck frame.
6. Contact Hendrickson for availability of beam lengths.
7. Shock absorbers are required in tractor and logging applications. Ride and traction may be improved in other applications with shock absorbers. Ride performance can be subjective and may be dependent on many factors beyond the suspension design, such as cab suspension, road conditions, body/auxiliary equipment, frame specifications, etc. Contact Hendrickson or your truck manufacturer/dealer for further information.
8. HAULMAAX EX 520 installed weight includes complete suspension, double rebound straps, longitudinal torque rods, Hendrickson TRAAX ROD® transverse torque rods, axle brackets and frame brackets; add 31 lbs. for shock absorbers.

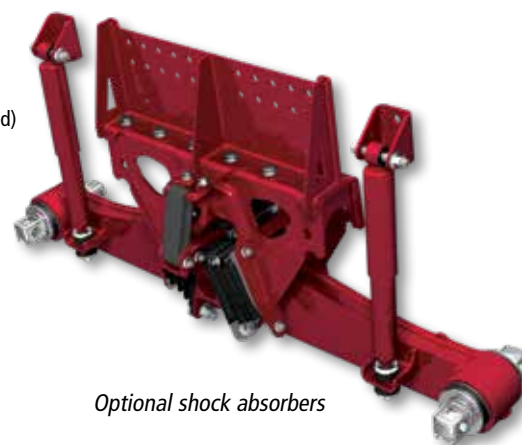

Optional shock absorbers

Technical literature available at www.hendrickson-intl.com or contact Hendrickson at 855.743.3733.

Hendrickson Genuine Parts are the same quality components installed in Hendrickson original equipment suspensions — consisting of the same design, construction, performance and durability. There's only one way to maintain and protect your suspension's original performance. Ask for the name that is synonymous with the finest manufactured suspensions in the world.

Extended Warranty options available at www.hendrickson-intl.com

Actual product performance may vary depending upon vehicle configuration, operation, service and other factors.

All applications must comply with applicable Hendrickson specifications and must be approved by the respective vehicle manufacturer with the vehicle in its original, as-built configuration. Contact Hendrickson for additional details regarding specifications, applications, capacities, and operation, service and maintenance instructions.

Call Hendrickson at **630.910.2800** or **855.RIDERED (743.3733)** for additional information.



www.hendrickson-intl.com

TRUCK COMMERCIAL VEHICLE SYSTEMS

800 South Frontage Road
Woodridge, IL 60517-4904 USA
855.RIDERED (743.3733)
630.910.2800 • Fax 630.910.2899

45745-507 Rev E 12-23

© 2019 - 2023 Hendrickson USA, L.L.C. All Rights Reserved. All trademarks shown are owned by Hendrickson USA, L.L.C., or one of its affiliates, in one or more countries. Information contained in this literature was accurate at the time of publication. Product changes may have been made after the copyright date that are not reflected.

Printed in United States of America