

H TECHNICAL PROCEDURE

TRAILER SUSPENSION SYSTEMS CXST SELF-STEER SUSPENSION

SUBJECT: CONNEX® ST Maintenance Procedures

LIT NO: T62001

DATE: January 2026

REVISION: E

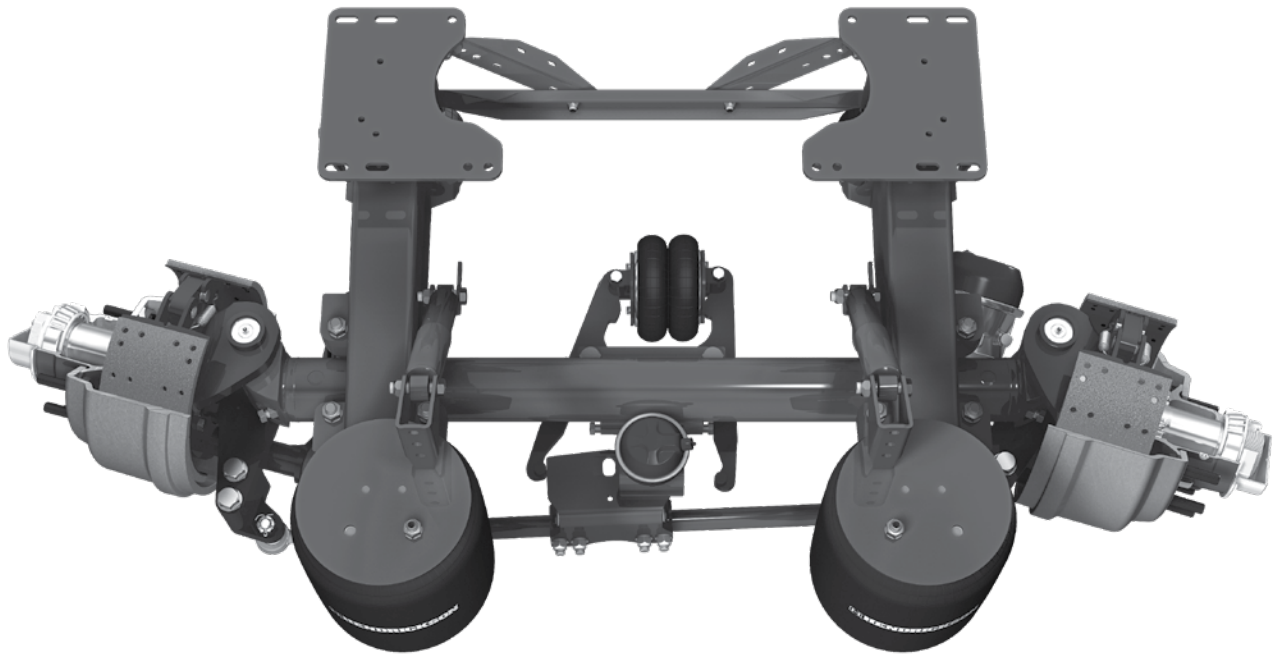



TABLE OF CONTENTS

Important Safety Notices 3

Conventions Applied in This Document..... 3

 Explanation of Signal Words 3

 Hyperlinks 3

 Contacting Hendrickson..... 3

 Relative Literature 4

Self-steer Axle Components and Lubrication Points 5

Introduction 6

 About self-steering 6

 Tools And Equipment..... 6

 Preventative Maintenance 6

 General Inspection..... 6

 Suspension Lubrication 7

Lock-Straight System 7

 Lock-straight Air Controls 8

 Lock-straight Assembly Inspection 8

 Lock-straight Center Adjustment..... 8

 Replace Lock-Straight Arm assemblies 9

Tie Rod Maintenance..... 10

 Remove Tie Rod Bracket 10

 Replace Tie Rod or Tie Rod End..... 10

 Reattach Tie Rod 11

 Reinstall Tie Rod Bracket..... 12

Axle Maintenance 13

 Axle component Inspection..... 13

 Kingpin Bushing Inspection 13

 Kingpin Bushing Replacement 14

 Remove wheel-end components..... 14

 Disconnect Tie Rod From Steering Knuckle..... 14

 Kingpin Disassembly 14

 Kingpin Reassembly..... 16

 Installing Kingpin Caps..... 18

 Wheel-cut Adjustment 19

Brake Components..... 20

Appendix A: Terms and Definitions 20

Appendix B: Fastener Torque Specifications 21



IMPORTANT SAFETY NOTICES

Hendrickson literature number T12007 Technical Procedure General Safety Precautions and Information, available at www.Hendrickson-intl.com/TrailerLit, includes important preparation, precautionary and safety information pertaining to the procedures included in this document.

To help prevent personal injury and equipment damage; warnings, cautions and other relative statements included in Hendrickson literature number T12007 are to be read carefully and applied during the performance of the procedures included in this document.

Improper maintenance, service or repair can cause damage to the vehicle and other property, personal injury, unsafe operating conditions and potentially void the manufacturer’s warranty.

CONVENTIONS APPLIED IN THIS DOCUMENT

Various techniques are used in this document to convey important information, express safety issues, provide methods for CONTACTING HENDRICKSON and how to identify and apply HYPERLINKS.

EXPLANATION OF SIGNAL WORDS

Hazard signal words (such as DANGER, WARNING or CAUTION) appear in various locations throughout this publication. Information accented by one of these signal words must be observed at all times. Additional notes are utilized to emphasize areas of procedural importance and provide suggestions for ease of repair. The following definitions comply with ANSI Z535.6 and indicate the use of safety signal words as they appear throughout the publication.

▲DANGER Indicates a hazardous situation that, if not avoided, will result in death or serious injury.

▲WARNING Indicates a hazardous situation that, if not avoided, could result in death or serious injury.

▲CAUTION Indicates a hazardous situation that, if not avoided, could result in minor or moderate injury.

NOTICE Indicates information considered important, but not hazard-related (e.g. messages relating to property damage).

IMPORTANT: An operating procedure, practice or condition that is essential to emphasize.

▲ or ▲ **Safety Alert Symbol** used to indicate a condition exists that, if not avoided, may result in personal injury or harm to individuals. It must be applied to DANGER, WARNING and CAUTION statements, which emphasize severity.

HYPERLINKS

Hyperlinks are identified by a dark grey line under the linked text. Internal links allow the reader to jump to a heading, step or page in this document. External links open the website or document referenced. While viewing electronically, activate the hyperlink by clicking on the underlined text.

CONTACTING HENDRICKSON

Contact Hendrickson Trailer Technical Services for technical assistance as needed. To do so, several options are available. Technical Services must be contacted before performing any warranty related service.

NOTE: DO NOT service a suspension or any component that is under warranty without first contacting Hendrickson Technical Services.

Prior to contacting Technical Services, it is best to have the following information about the vehicle and Hendrickson suspension available (all that apply):

- **Hendrickson suspension** information, (refer to L977 Suspension and Axle Identification) –
 - Suspension model number
 - Suspension serial number
 - Approximate number of suspension miles
- **Trailer information** (located on VIN plate) -
 - Type (van, reefer, flat bed, etc...)
 - Manufacturer
 - VIN (vehicle identification number)
 - In-service date¹
 - Fleet/owner name
 - Unit #

¹ If the in-service date is unknown or not available, the vehicle date of manufacture will be substituted.



- **Failure information**
 - Description of the system problem, the part number and/or the part description of the reported non-functioning part.
 - **Date of failure.**
 - Where applicable, **location of problem** on suspension / trailer (e.g., road side, front axle, rear axle, curb side rear, etc.).
- **Digital photos** of suspension and damaged areas.
- **Special application** approval documentation (if applicable).

PHONE

Contact **Hendrickson Trailer Technical Services** directly in the United States and Canada+ at **866-RIDEAIR (743-3247)**. From the menu, select:

- **Technical Services/Warranty** for technical information.
- Other selections include:
 - **Aftermarket Sales** for replacement parts information and ordering.
 - **Original Equipment Sales** for parts inquiries and ordering for trailer manufacturers.

EMAIL

HTTS@Hendrickson-intl.com

Contact Hendrickson for additional details regarding specifications, applications, capacities, and operation, service and maintenance instructions.

All applications must comply with applicable Hendrickson specifications and must be approved by the respective vehicle manufacturer with the vehicle in its original, as-built configuration.

RELATIVE LITERATURE

If you suspect your version of this or any other Hendrickson manual is not “up-to-date”, the most current version is free online at:

www.Hendrickson-intl.com/TrailerLit

Available Hendrickson documentation can be viewed or downloaded from this site.

All Hendrickson online documentation is in PDF format that requires PDF reader software to open. A free application is downloadable from Adobe at <http://get.adobe.com/reader/>.

Other relative literature may include:

NAME	DESCRIPTION
Various	<i>Installation drawing, contact Hendrickson</i>
B106	<i>Pivot Bushing Inspection Procedure</i>
L459	<i>Checking Trailer Ride Height</i>
L578	<i>Inspection and Lubrication</i>
L579	<i>Alignment Procedures</i>
L583	<i>Comprehensive Warranty Statement</i>
L974	<i>Drum Brake Maintenance Procedures</i>
T12007	<i>General Safety Precautions for Technical Literature</i>
L1250	<i>Trailer Self-Steer Suspension Application Guide</i>
L1277	<i>CONNEX® ST Parts List</i>
T61001	<i>Self-steer Suspension Installation and Requirements</i>

Table 1: Relative Literature

Hendrickson reserves the right to make changes and improvements to its products and publications at any time. For the latest version of this manual Consult the Hendrickson website:

www.Hendrickson-intl.com/TrailerLit

PREPARING TRAILER FOR MAINTENANCE SERVICE

Information for trailer preparation, safety and precautionary statements, refer to Hendrickson literature number T12007, available at www.Hendrickson-intl.com/TrailerLit.

NOTE: DO NOT service a suspension or any components that is under warranty without first contacting Hendrickson Technical Services. Refer to CONTACTING HENDRICKSON for details.

⚠WARNING DO NOT work under a trailer supported only by jacks. Jacks can slip or fall over, resulting in serious personal injury. Always use safety stands to support a raised trailer.

SELF-STEER AXLE COMPONENTS AND LUBRICATION POINTS

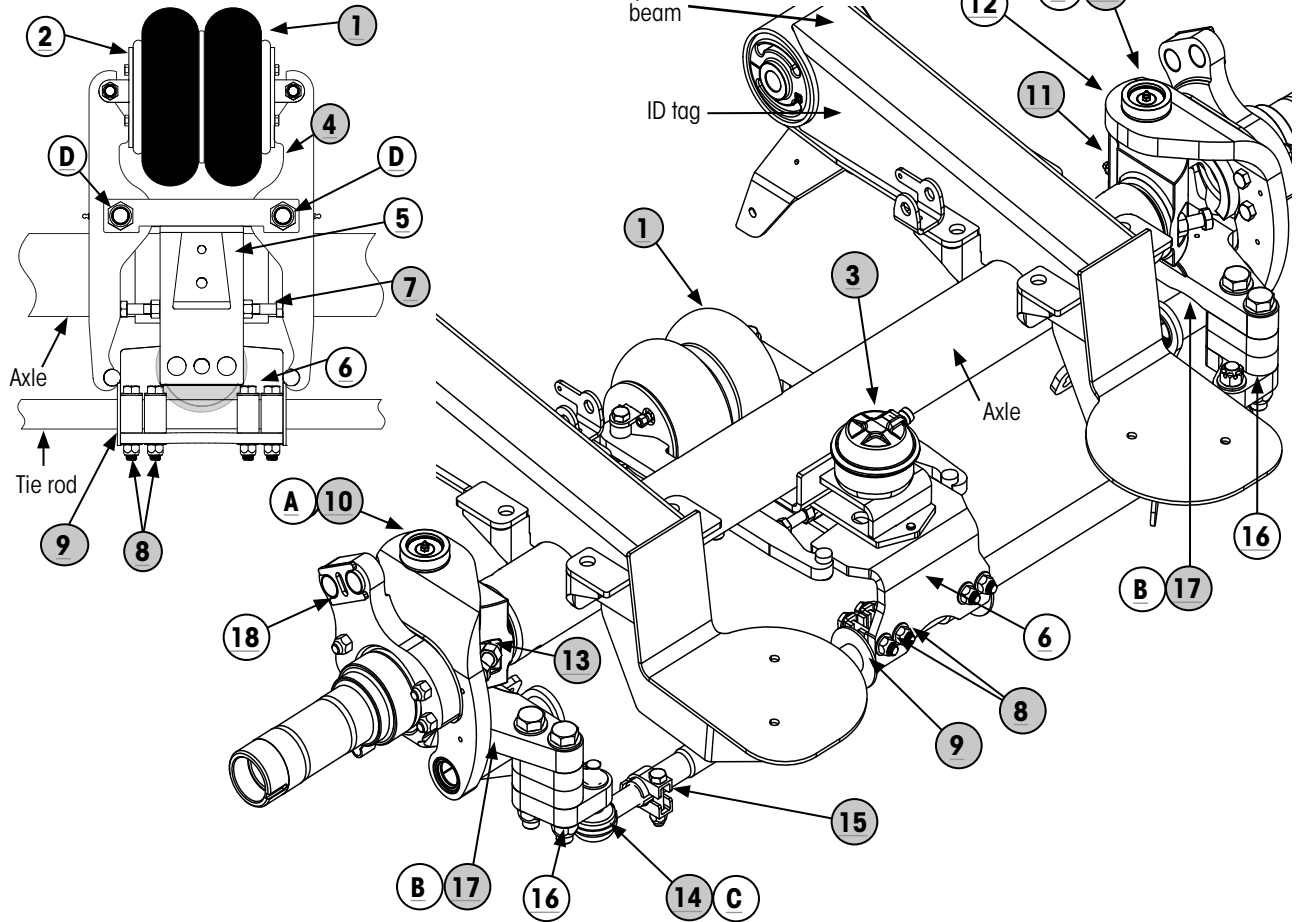
Lock-straight Assembly (bottom view)

Figure 1: Self-steer axle components (Axle configuration may vary)

LOCK-STRAIGHT ASSEMBLY COMPONENTS	
Item	Description
1	Lock-straight air actuator
2	Actuator plate (x2)
3	Lock-straight air chamber
4	Arm assembly (x2)
5	Locking assembly (welded to axle)
6	Tie rod bracket
7	Stop bolt and jam nut (x2)
8	Locking clamp (x4)
9	Tie rod washer (x2)

AXLE COMPONENTS	
Item	Description
10	Kingpin assembly(x2)
11	Draw key (x2 Before March 2024), (x4 After March 2024)
12	Steering knuckle (x2)
13	Wheel-cut stop bolt and jam nut (x2)
14	Tie rod ends (x2)
15	Locking clamp (x2)
16	Steering arm assembly (x2)
17	Cam tube (x2)
18	Brake spider (x2)

Table 2: Self-steer axle component descriptions

POINT	GREASE FITTING	ACTION	FREQUENCY
A	Kingpin, top & bottom	Lubricate with NLGI #2 EP grease	Monthly
B	Cam tube		
C	Tie rod end		
D	Arm assembly pivot		

Table 3: Lubrication points

DRAW KEY AXLE ENDS

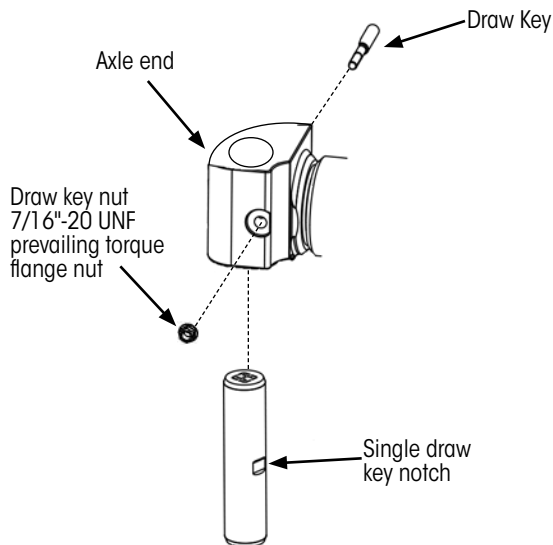

Figure 2: Single draw key axle end
(Before March 2024)

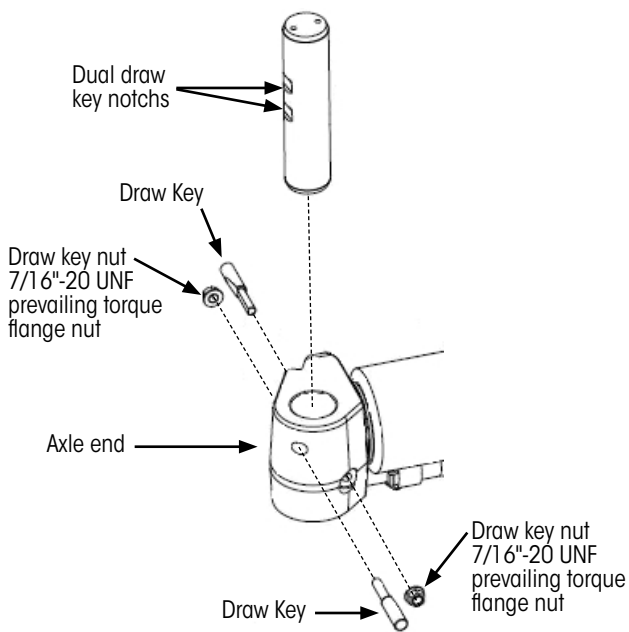

Figure 3: Dual draw key axle end
(After March 2024)

INTRODUCTION

ABOUT SELF-STEERING

The suspension is designed to self-steer while the trailer is moving forward only. If the wheels are not locked straight or lifted while moving in the reverse direction, the wheels may steer left or right to the wheel-cut position. This could result in scrubbing of the tires or damage to suspension components. For more information, refer to [LOCK-STRAIGHT SYSTEM](#) on page 7.

TOOLS AND EQUIPMENT

The following tools and equipment are necessary to complete the procedure within this publication:

- Refer to [APPENDIX B: FASTENER TORQUE SPECIFICATIONS](#) on page 21 for wrench/socket sizes.
- $\frac{3}{8}$ inch pin punch or equivalent.
- 12 foot (minimum) steel tape measure with $\frac{1}{32}$ inch increments.
- Dial indicator with magnetic base.
- Kingpin removal tool.
- Tire changing equipment (as needed).
- Angle measuring instrument (magnetic protractor) for self-steer axle.
- Wheel chocks.
- Frame jacks or supports.

PREVENTATIVE MAINTENANCE

To ensure the suspension system continues to operate and function safely, preventative maintenance practices must be preformed. For recommended general suspension preventive maintenance procedures, refer to Hendrickson literature number L578. This section includes recommended preventative maintenance procedures relative to self-steer axle operation.

GENERAL INSPECTION

In preparation for all inspection procedures, refer to [PREPARING TRAILER FOR MAINTENANCE SERVICE](#) on page 4. It may not be necessary to lift the trailer.

Table 2 and Table 3 on page 5 list inspection and lubrication points respectively for self-steer axle components. A general inspection should include:

- A. Signs of wear, corrosion or damage.
- B. Loose or missing fasteners and components.
- C. Weld integrity of all welds.
- D. Integrity of air systems; no leaks in hoses or fittings.
- E. Operationally check performance to ensure all moving parts functioning normally.



SUSPENSION LUBRICATION

In most instances, among others, lubrication serves two primary purposes:

- A. Minimize the effects of friction (wear and heat) between two or more surfaces in close proximity to each other and share relative motion.
- B. Remove air from voids which, if not otherwise filled, may harbor harmful contaminants (moisture, debris, etc.).

Table 3 on page 5 includes required lubrication points for the self-steer axle. The required grease is NLGI #2 EP. Prior to replenishing grease, clean area around each grease fitting and the associated joint.

MONTHLY REQUIREMENTS

- A. Cam tube - one grease fitting for each. Apply grease until fresh lubricant can be seen at the slack adjuster end.
- B. Tie rod end - one grease fitting for each. Apply grease until the rubber boot expands and until fresh lubricant purges from around the rubber boot crimp.

NOTICE Over greasing can rupture the rubber boot, allowing grease to escape and contaminants or debris to enter.

- C. Slack adjuster (not shown) - apply grease according to vendor recommendations.
- D. Locking arm - one grease fitting for each arm Figure 4.

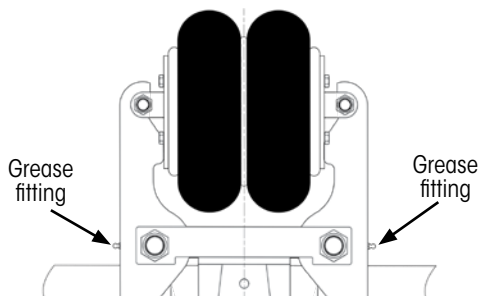

Figure 4: Locking arm lubrication

- E. Kingpin - upper and lower grease fittings on the top and bottom of the steering knuckle. Apply

grease until fresh grease can be seen exiting from joints shown in Figure 5.

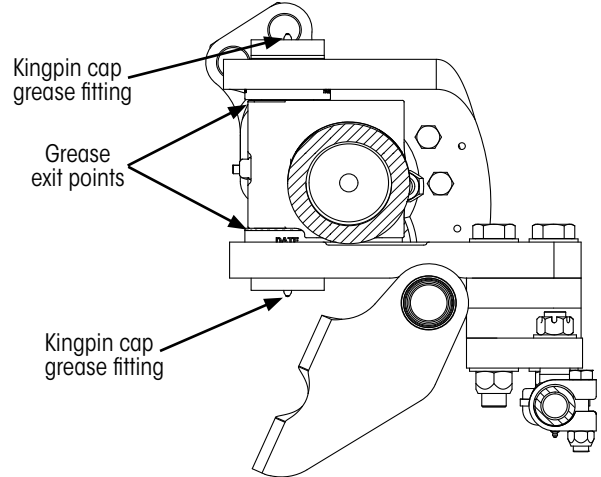

Figure 5: Kingpin lubrication

LOCK-STRAIGHT SYSTEM

The lock-straight system is used to:

- A. Dampen self-steering of the wheels while the trailer moves forward.
- B. Hold the wheels straight forward and the tie rod in center position while the trailer moves in reverse.

FORWARD MOVEMENT

When moving in the forward direction, wheels will self-steer with the vehicle. If not restrained, the wheels will move erratically. The lock-straight system dampens steering by resisting tie rod movement.

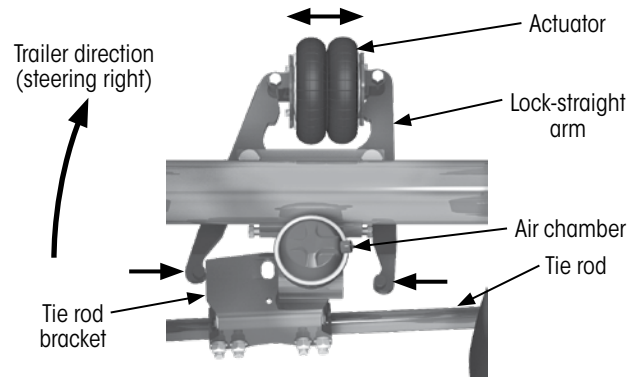

Figure 6: Dampening action, steering to the right

While the trailer is operating, regulated 25±5 psi air pressure is continuously supplied to the actuator (Figure 6). Dampening is accomplished as the actuator attempts to expand at the front end of the lock-straight arms to hold the tie rod bracket and tie rod at the center position at the opposite end.



While moving forward, the air chamber (Figure 6) must remain disengaged (no air in the chamber) with its centering pin retracted.

REVERSE MOVEMENT

NOTICE If the wheels are allowed to move to a wheel-cut position, they could lockup and scrape on the surface. This action can damage suspension components.

While traveling in reverse, if not properly managed, the wheels will quickly move to a wheel-cut position. This could result in scrubbing of the tires and possible suspension damage.

To prevent this, the air chamber (Figure 6 on page 7) must be engaged (air in the chamber) to move its centering pin through the centering lock holes in the lock-straight assembly, see Figure 7. Optionally, a lift control can be added to also lift the axle.

IMPORTANT: With air applied to the lock-straight chamber, the locking pin is engaged, but may not be aligned and through the centering holes of the assembly. Moving the trailer straight forward before moving in reverse will allow the actuator to align the wheels straight forward, center the tie rod bracket and align the locking pin with the centering holes.

LOCK-STRAIGHT AIR CONTROLS

The CONNEX® ST suspension LOCK-STRAIGHT SYSTEM requires an air control kit for the air actuator and air chamber. Hendrickson recommends including an optional lift control kit with an applicable backup control.

While raised, the axle should be forced and held to the center position by the air actuator. Further, the wheels must be properly aligned when the axle is lowered for forward trailer motion. This will minimize scrubbing of the tires as wheels lower and contact the road surface.

As instructed in installation drawing D-36237¹, the trailer OEM must supply all required air controls. Refer to manufacturer's documentation for information on OEM provided self-steer axle centering, lift and backup control kits.

¹ An installation drawing is provided with each CONNEX ST suspension. Generic versions are listed in Hendrickson literature number T61001 and available online at www.hendrickson-intl.com/TrailerLit. Where duplication exists, refer to installation drawing.

LOCK-STRAIGHT ASSEMBLY INSPECTION

This inspection is recommended to ensure the lock-straight assembly is free of any obstruction or damage which could restrict movement.

Components to inspect include:

ITEM ¹	DETAILS
1	Lock-straight actuator Visually inspect for signs of wear in flex member.
3	Lock-straight air chamber - Ensure locking pin extends into holes when air is applied.
4	Lock-straight arm assembly - Ensure the arms move freely and unobstructed as the wheels are turned. The arms include bushings at the pivot connections. If showing signs of excessive vertical motion and/or wear, the arms should be replaced.
7	Lock-straight bolt and jam nut - Ensure locked in position by jam nut and contact with the arms when in center position.
8	Locking clamp - check to ensure clamp is tight ² .
9	Tie rod washer - check to ensure in place and weld integrity is good.
N/A	Lock-straight contact points (Figure 7)- These four points must be contacting, metal-to-metal, when the lock-straight system is activated. Refer to LOCK-STRAIGHT CENTER ADJUSTMENT.

¹ Item numbers are from Figure 1 on page 5.
² For torque values, refer to FASTENER TORQUE SPECIFICATIONS on page 21.

Table 4: Lock-straight inspection point details

LOCK-STRAIGHT CENTER ADJUSTMENT

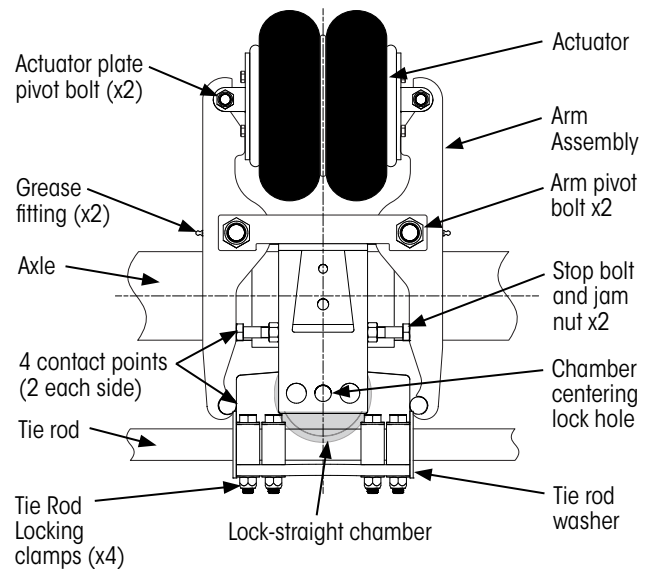

Figure 7: Self-steer axle lock-straight assembly (Bottom view)

During axle alignment or other applicable adjustment of the self-steer axle, the tie rod and wheels (Figure 7 on page 8) must be locked in the center position. Refer to L579 Alignment Procedures for needed adjustments.

Inspect arm assemblies for signs of wear, damage or loose fit. Replace if needed before continuing. See REPLACE LOCK-STRAIGHT ARM ASSEMBLIES.

REPLACE LOCK-STRAIGHT ARM ASSEMBLIES

The lock-straight system includes two opposing arms (Figure 7 on page 8) with bushings located at the pivot bolts. Wear can occur at the four contact and pivot points. If worn or damaged, both arm assemblies should be replaced.

1. Follow LOCK-STRAIGHT CENTER ADJUSTMENT.
2. **Relieve pressure** at the trailer air tank to depressurize air in the lock-straight air actuator.
3. **Remove** the air hose feeding air actuator.

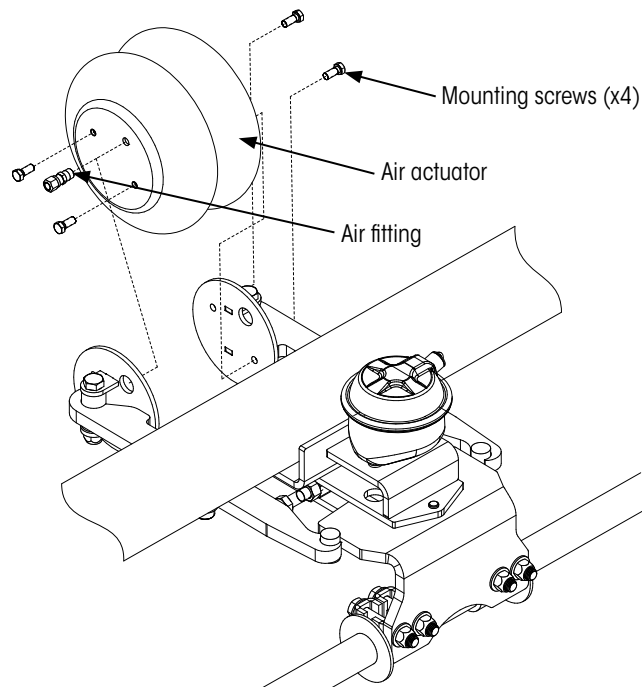

Figure 8: Removing lock-straight air actuator

4. **Remove** the air actuator (Figure 8) by extracting the air fitting and four mounting screws. **Set aside** for later reassembly.

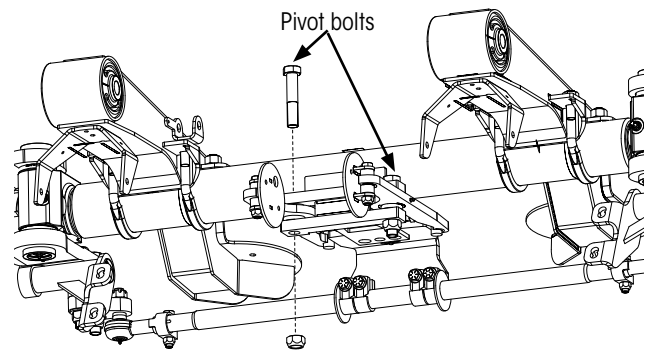

Figure 9: Lock-straight arm assembly pivot bolt removal

5. **Remove** lock-straight arm pivot bolts (Figure 9) for both lock-straight arm assemblies.

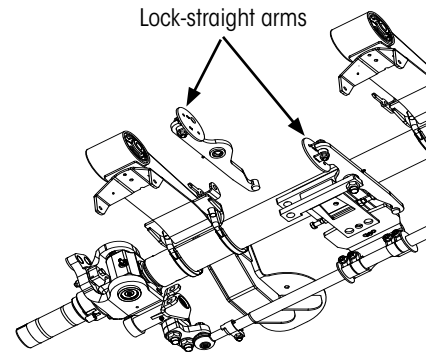

Figure 10: Lock-straight arm assembly removal

6. **Remove** both lock-straight arm assemblies (Figure 10).
7. **Reverse** the above steps to **install** new lock-straight arm assemblies.
8. **Tighten** all fasteners to values specified in FASTENER TORQUE SPECIFICATIONS on page 21.
9. **Follow** LOCK-STRAIGHT CENTER ADJUSTMENT on page 8 procedure, refer to L579 Alignment Procedures, to adjust lock-straight center position.

NOTICE

Steps must be taken to ensure lock-straight adjustments are returned to previous settings with wheels aligning straight when in centered position. Not doing so can result in improper toe, excess tire wear and/or erratic self-steer axle performance.

TIE ROD MAINTENANCE

INSPECT TIE ROD ASSEMBLY

Checking for excessive movement at both ends of the tie rod assembly.

1. **Remove** the tie-rod bracket by detaching the locking bracket to allow free rotation and inspection of the tie-rod assembly.
2. **Visually** inspect the cross-tube and check for bends, dents, damaged threads, or movement near tie-rod ends. Replace the entire assembly if it is damaged.
3. **Visually** inspect both tie-rod ends to ensure the ball stud is fully seated, no cracks or tears in the grease boots, no damage to grease zerk, or threaded ends. Cotter pins and castle nuts are in place and not damaged or loose.
4. Verify that threaded ends extend beyond the slot depth in the cross-tube. There should be no air gap between the slot end and the threads.
5. Check cotter pins and castle nuts and ensure pins and nuts are present and secure. If missing refer to REATTACH TIE ROD on page 11, for castle nut torque instructions.
6. Inspect clamps and bolts and confirm tie-rod end clamp bolts are on the rear side of the cross-tube. Check tie rod bracket clamps, bolts, and washer for any damage.
7. Check steering movement by turning wheels fully left and right and ensure clamps and bolts do not contact other components. If binding occurs, replace both tie-rod ends.
8. Check vertical end play by using both hands to move the tie-rod vertically (up and down) near each tie-rod end.
 - A. If movement is detected. Attach the dial indicator to the knuckle, place the tip on the bottom of the tie-rod end near the grease fitting.
 - B. Set the dial indicator to zero, repeat vertical movement, and interpret results:
 - i. If play ≤ 0.060 " – Good
 - ii. If play > 0.060 " to < 0.125 " – Replace ends at next service

- iii. If play ≥ 0.125 " – Remove vehicle from service and replace ends. Refer to REPLACE TIE ROD OR TIE ROD END.

9. Once inspection is complete reattach tie rod bracket and center clamp hardware. Refer to REINSTALL TIE ROD BRACKET

REMOVE TIE ROD BRACKET

This bracket must be removed to replace the tie rod or tie rod end(s).

IMPORTANT: The tie rod bracket is aligned between the tie rod washers. If the tie rod washers have shifted for any reason or installing a new tie rod assembly, they will have to be realigned after reattaching the tie rod. Refer to L579 ALIGNMENT PROCEDURES.

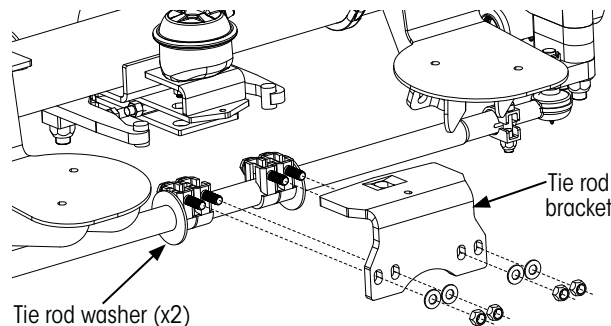

Figure 11: Lock-straight tie rod bracket

1. **Remove** the four tie rod bracket locking clamp bolt, nut and washers (Figure 11). **Save** for reassembly.
2. **Remove** tie rod bracket.

REPLACE TIE ROD OR TIE ROD END

Follow this procedure to replace one or both tie rod ends. Follow applicable steps for replacing the tie rod assembly.

NOTE: Tie rod ends have opposing left/right threads and must attach to the correct end of the tie rod.

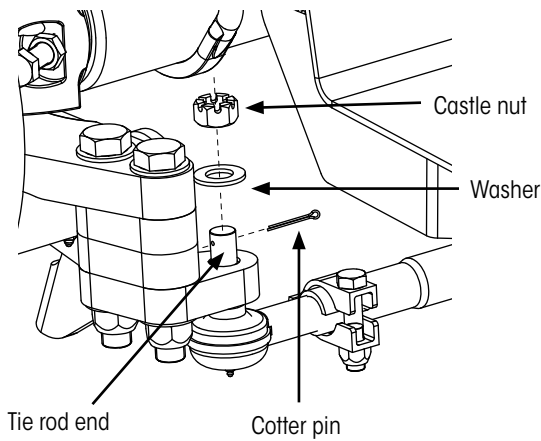

Figure 12: Remove tie rod fasteners

1. **Remove** the cotter pin and castle nut on the tie rod end to be replaced (Figure 12). Remove from both ends if both tie rod ends or the entire tie rod assembly is to be replaced.

NOTE: New fasteners will be provided with the new tie rod assembly or tie rod end.

2. If replacing the tie rod assembly (Figure 14 on page 11), **go to REATTACH TIE ROD, ON PAGE 11.**

NOTICE The clamp and bolt must be orientated as shown to avoid interference among moving parts.

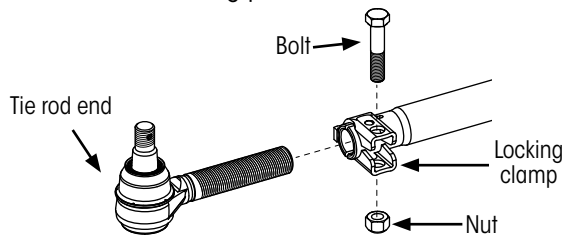

Figure 13: Tie rod end disassembly

3. **Loosen** tie rod end locking clamp (Figure 13). It should not be necessary to remove tie rod end clamp hardware.
4. **Count and record** the number of turns required to **unthread** tie rod end from the tie rod and **discard**.
5. **While threading** the new tie rod end into the tie rod, **count** the number of turns and match the number of turns recorded in Step 4.

NOTE: Threaded ends of tie rod ends are to be engaged deeper than the end of the tie-rod cross-tube slot. There should be no air gap visible between the end of the tie-rod cross-tube slot and threaded portion of the tie-rod end, Figure 14.

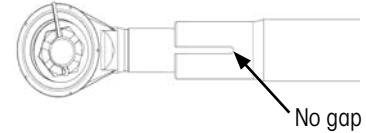

Figure 14: Tie rod end no gap

6. If removed, **reinstall** tie rod end clamp hardware, but **DO NOT** tighten.

IMPORTANT: The tie rod end clamp will be tightened after the tie rod is reassembled to the suspension. Be sure to add grease to tie rod ends when complete.

REATTACH TIE ROD

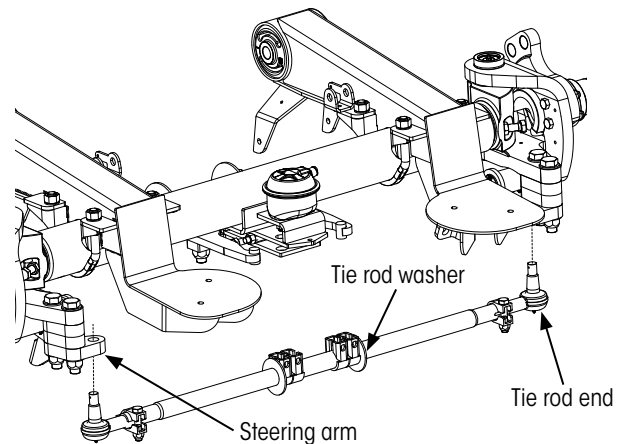

Figure 15: Remove/attach tie rod assembly

1. **Clean** the area around the steering arm and the hole for the tie rod end(s).
2. **Insert** the tie rod end into the steering arm (Figure 15). If applicable, **repeat** for the opposite end.

IMPORTANT: If replacing tie rod assembly, visually check to ensure both tie rod ends extend the same length beyond the tie rod.

3. **Install** washer and tie rod end castle nut onto tie rod end(s) (Figure 13).



4. **Tighten** the tie rod end castle nut to the specified torque¹, then advance to the nearest cotter key hole.

IMPORTANT: **DO NOT** back-off nut to align to cotter key hole.

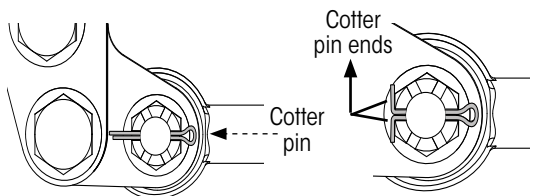

Figure 16: Tie rod end cotter key install

5. **Insert** the cotter pin through castle nut and tie rod end, as shown in Figure 16.

REINSTALL TIE ROD BRACKET

During installation, the tie rod bracket must be properly centered and vertically aligned to prevent binding.

1. **Install** tie rod bracket, as shown in Figure 17, using hardware removed in Step 2 of REMOVE TIE ROD BRACKET on page 10 . **DO NOT** tighten at this time.

NOTE: A new tie rod will include tie rod bracket clamps and tie rod washers, but may not include fasteners. These clamps will be tightened after realignment of the tie rod bracket.

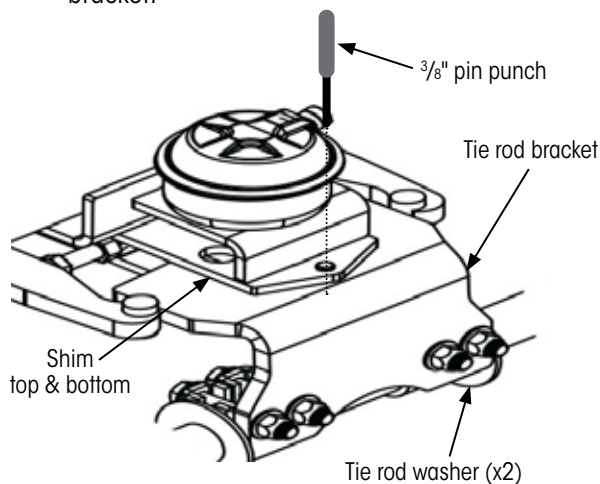

Figure 17: Positioning tie rod bracket

2. **Ensure** the tie rod bracket is correctly positioned in the lock-straight assembly shown in Figure 17.

3. **Manually lock** the lock-straight assembly with a 3/8 inch pin punch (or equivalent) as shown in Figure 17.

NOTE: Alternately, air can be supplied to the lock-straight actuator, first, and, second, to the chamber to hold the tie rod bracket in position.

4. **Temporarily shim** above and below tie rod bracket (Figure 17) to evenly space (center) the tie rod bracket vertically in lock-straight assembly.
5. **Refer to L579 Alignment Procedures** for alignment.
6. **If tie rod washers** (Figure 17) **are loose**, refer to installation drawing D-36237² for instructions on tack welding the washers in place.
7. **Remove** shims installed in Step 4.
8. **Undo** the temporary lock performed in Step 3.
9. **Restore** trailer to normal operating state.

¹ A complete list of torque values can be found at FASTENER TORQUE SPECIFICATIONS on page 21.

² An installation drawing is provided with each CONNEX® ST suspension. Generic versions are listed in Hendrickson literature number T61001 and available online at www.hendrickson-intl.com/TrailerLit. Where duplication exists, refer to installation drawing.



AXLE MAINTENANCE

This section includes maintenance procedures specific to the CONNEX® ST self-steer axle and knuckle assembly. For maintenance applicable to the attached CXST suspension system and wheel-end, refer to Hendrickson literature number L578 and other related literature listed in T61001. For more information refer to CONTACTING HENDRICKSON on page 3.

AXLE COMPONENT INSPECTION

Along with recommended preventive maintenance listed in Hendrickson literature number L578, refer to Table 5 for information and procedures relative to the inspection and maintenance of the CONNEX ST self-steer axle and lock-straight components.

ITEM ¹	DETAILS
10	Kingpin - Refer to KINGPIN BUSHING INSPECTION.
11	Draw key - ensure key is present and jam nut remains tight ² .
13	Wheel-cut stop bolt and jam nut - ensure bolt is not missing and jam nut is tight ² . Refer to WHEEL-CUT ADJUSTMENT on page 19.
14	Tie rod ends - steering is free and unobstructed through to stops, no leaks or damage to grease boot. Refer to TIE ROD MAINTENANCE on page 10.
15	Locking clamps - Ensure tight ² and positioned horizontal, facing rearward as shown in Figure 1 on page 5.
17	Cam tube - Refer to L974 Drum Brake Maintenance Procedures for S-cam, cam tube and other brake component inspection.

¹ Item numbers are from Figure 1 on page 5.
² For torque values, refer to FASTENER TORQUE SPECIFICATIONS on page 21.

Table 5: Axle inspection point details

KINGPIN BUSHING INSPECTION

This inspection should be performed quarterly to check for possible excess wear and proper operation of the kingpin connection at both ends of the axle.

Checking Upper Kingpin Bushing



Figure 18: Checking upper kingpin bushing

1. **Affix** a magnetic base dial indicator on the axle and place the tip of the dial indicator on the inside of the upper kingpin connection as shown in Figure 18.
2. **Set** the dial indicator to "0" zero.
3. **Move** the top of the tire in and out by applying reasonable, constant pressure and then releasing.
4. **Check and record** reading at both in and out positions on the dial indicator.

If the dial indicator moves more than 0.025", the upper bushing is worn or damaged. Replace both kingpin bushings. Refer to KINGPIN BUSHING REPLACEMENT.

Checking Lower Kingpin Bushing

5. **Affix** a dial indicator so the magnetic base is on the axle and the indicator tip is against the inside of the bottom of the knuckle, similar to Figure 15 for the upper kingpin bushing.
6. **Set** the dial indicator to "0" zero.
7. **Repeat** steps 3 and 4.

IMPORTANT: If either bushing is worn or damaged, it is mandatory to replace both the top and bottom bushings on that knuckle assembly and, if necessary, the kingpin.



KINGPIN BUSHING REPLACEMENT

Applicable components must be replaced if damaged or worn beyond specifications as determined by KINGPIN BUSHING INSPECTION.

Use the following procedures to remove and replace both kingpin housings.:

REMOVE WHEEL-END COMPONENTS

This is recommended to ensure the performance of these procedures are safer and more manageable. These components can also interfere with disassembly and reassembly of parts.

1. Remove the wheel and drum.

NOTE: For wheel-end maintenance procedures, refer to applicable online RTR wheel-end maintenance procedures listed at www.Hendrickson-intl.com/TrailerLit.

2. Refer to the applicable wheel-end maintenance literature for procedures on how to remove the hub.
3. Remove the brake components from the spider. Refer to *L974 Drum Brake Maintenance Procedures* for details.

DISCONNECT TIE ROD FROM STEERING KNUCKLE

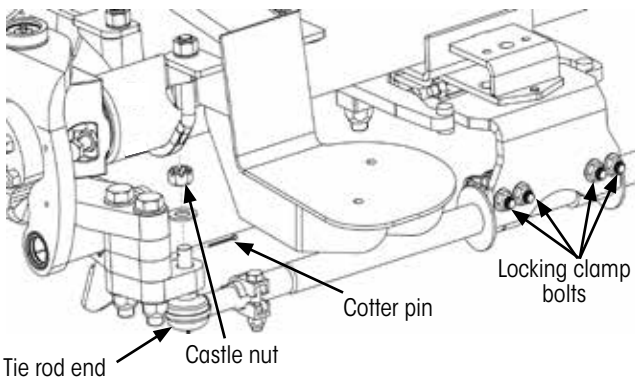

Figure 19: Aligning tie rod lock plate

1. The tie rod bracket should be held in position by the lock-straight air chamber pin. If the centering pin is not in place, insert a 3/8 inch pin punch (or equivalent) as shown in Figure 17 on page 12.
2. Using wrench or socket¹, remove the four locking clamp bolts (Figure 19) holding the tie rod bracket to the tie rod. Save for reassembly.
3. Remove the cotter pin (Figure 19) from the tie rod end castle nut.

¹ Refer to FASTENER TORQUE SPECIFICATIONS on page 21 for tool sizes.

4. Using wrench or socket¹, remove the castle nut and washer from the tie rod end. Save for reassembly.
5. Using drift pin and hammer, push out the tie rod end from the steering arm and move the tie rod to a safe position.

NOTICE

If the tie rod end is damaged, refer to REPLACE TIE ROD OR TIE ROD END on page 10.

KINGPIN DISASSEMBLY

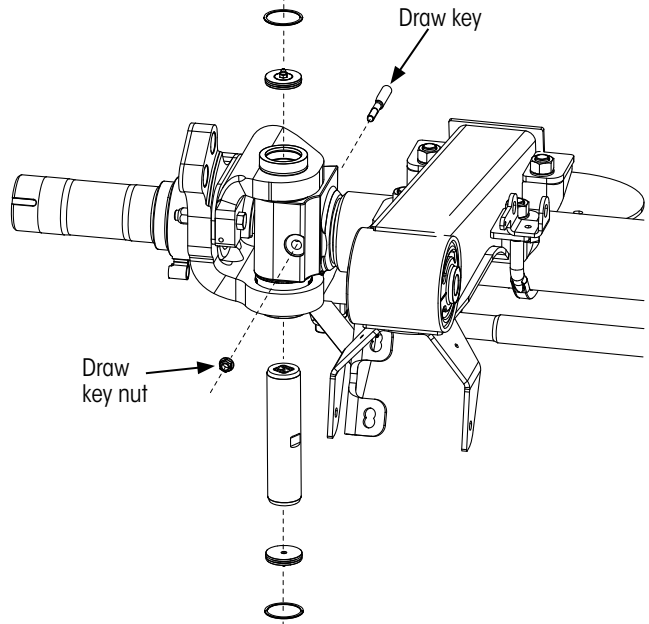

Figure 20: Kingpin before March 2024

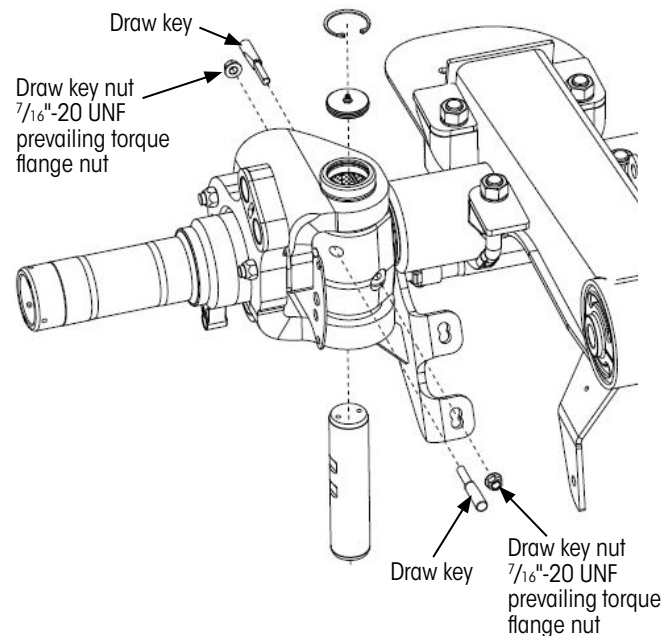

Figure 20A: Kingpin after March 2024



1. **Remove** top and bottom retaining rings (Figure 20 and, 20A) securing the kingpin caps in position.

NOTE: The service kit will include two retaining rings and kingpin cap assemblies.

2. Using wrench or socket¹, **remove** grease fitting from each kingpin cap.

NOTE: This procedure uses a hex head screw to force the kingpin cap out of the kingpin housing assembly. Other methods may be applied, but must be safe and not damage the kingpin or kingpin housings.

3. **Thread** a 3/8-24 1 1/2 inch long (minimum length) hex head screw into the center hole, 1/8-NPT, of each cap.
4. **Turn** screw into the center of the cap until the cap separates enough to **remove** it from the kingpin housing with a pry bar. **Discard** the cap and screw.

NOTE: DO NOT reuse the screw and cap. They will likely be damaged during cap removal.

5. **Repeat** Step 4 to remove the opposite kingpin cap.

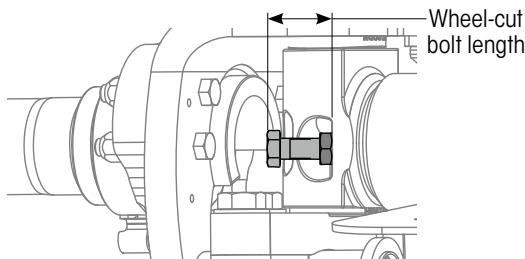

Figure 21: Wheel-cut bolt length measurement before March 2024

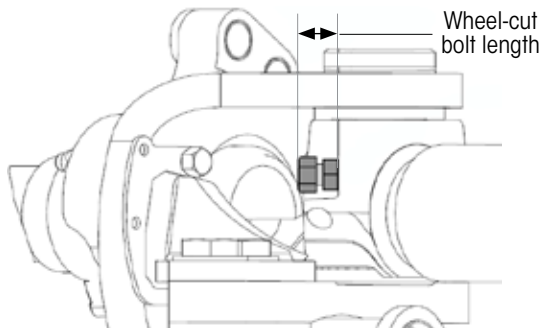

Figure 21A: Wheel-cut bolt length measurement after March 2024

6. **Measure** (Figure 21, and 21A) and **record** current wheel-cut bolt length. Refer to [Table 6 on page 19](#).

NOTE: This value is required to restore bolt to its original length during reassembly. The length should be the same on both sides. The bolt on suspensions manufactured before March 2024, interfere with the draw key the bolt must be removed.

7. **Remove** the wheel-cut bolt and jam nut. **Save** for reassembly in [Step 4 on page 19](#).
8. Using wrench or socket¹, **remove** the draw key nut (Figure 20 and, 20A on page 14).
9. Using drift pin and hammer, **remove** the draw key that engages the kingpin. **Discard** draw key.

NOTE: If removal of the draw key proves difficult, an air hammer can be used with a drift punch attachment.

CAUTION To avoid component damage and/or personal injury, the knuckle must be supported before removal of kingpin. Removal of kingpin will allow the entire steering knuckle to separate from the suspension.

10. **Remove** the kingpin by pushing it through the knuckle assembly and axle end in either direction. **Discard** kingpin.

NOTICE DO NOT heat the axle to remove the kingpin. If necessary, refer to [CONTACTING HENDRICKSON on page 3](#) for assistance.

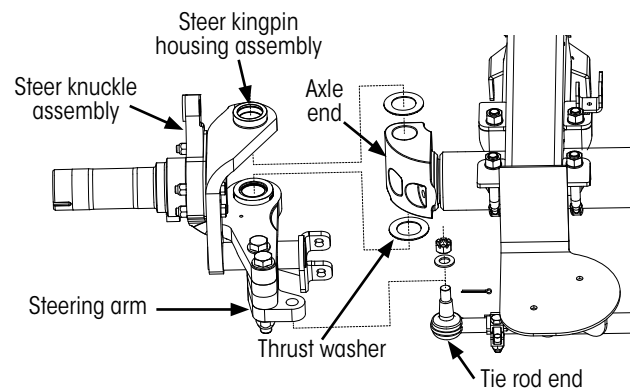

Figure 22: Steer knuckle removal

11. **Remove** the steer knuckle (Figure 22) by sliding it off the axle end. The thrust washer will fall from the connection.
12. **Discard** thrust washer.

NOTE: DO NOT reuse the thrust washer. A replacement is included with the service kit.

NOTE: A Hydraulic press with a minimum force capacity of 5 tons will be required for this procedure.

⚠WARNING Before applying Hydraulic pressure to any tooling set-up, always check to ensure the press plate, adapters and components being worked on are positioned properly, I.E. "IN LINE" with the ram of the press. Improper positioning can cause personal injury and/or component damage.

13. **Thoroughly** clean all machined surfaces.
14. Place knuckle in a hydraulic press.
15. Make sure to support in between the knuckle plates when pressing out the kingpin housing and ensure that the kingpin housing sits in line with the press.
16. **Press** out each kingpin housing assembly by forcing it inward to the knuckle (Figure 23).

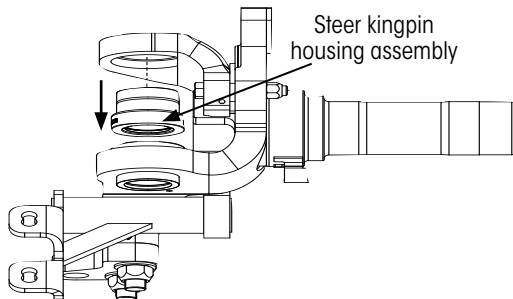

Figure 23: Removing kingpin bushings

17. Inspect exposed machine surfaces of the knuckle to ensure surfaces are clean and corrosion free.
18. Make sure the knuckle bore diameter measures $2.996 \pm .001$.
19. Correctly position new kingpin housing assemblies, upper and lower, and press them in place one at a time until fully seated.
 - A. To determine if the steer kingpin housings are fully seated verify that the steer kingpin

housing to kingpin housing distance is $5.450 \pm .015$ (Figure 24 on page 16).

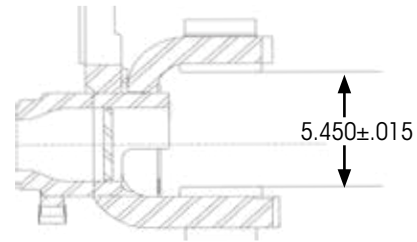

Figure 24: Kingpin housing distance

20. Check alignment by sliding the new kingpin through both kingpin housings to ensure no binding is present (Figure 25).
 - A. Inspect kingpin housings for burrs or other obstructions.
 - B. Check for damage or deformation in knuckles.

KINGPIN REASSEMBLY

Following this procedure for recommended kingpin assembly.

1. **Thoroughly clean** the contact surfaces for the steering arm and tie rod end (Figure 15 on page 11). **Thoroughly clean** the hole in the axle end for the kingpin (Figure 25).
2. **Slide** kingpin into axle end to ensure it moves easily in and out. If not, return to Step 2.
3. **Remove** kingpin.

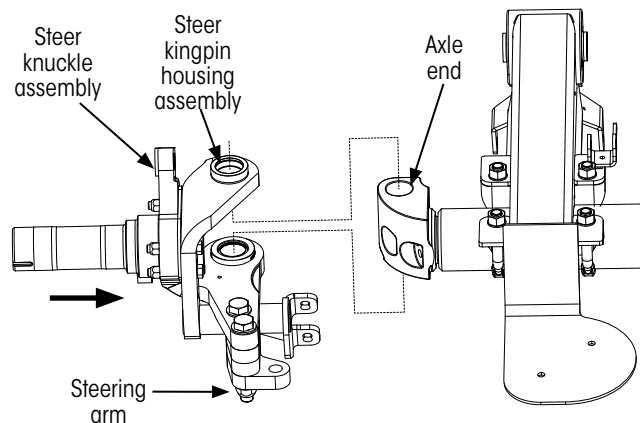

Figure 25: Steer knuckle installation (Axle configuration may vary)

4. **Position** the steer knuckle (Figure 25) over the axle end and align to kingpin hole.

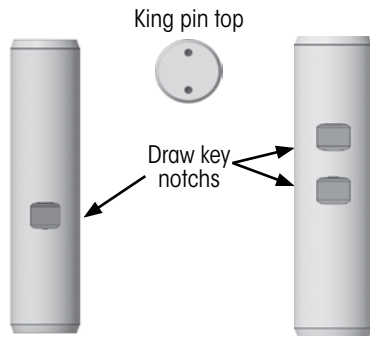

Figure 26: Kingpin dual draw key

IMPORTANT: If not clearly marked, the top of the kingpin can be determined by the presence of two holes on the top.

NOTICE If the kingpin is not closely aligned relative to the draw key, the draw key and/or kingpin can be damaged during draw key insertion.

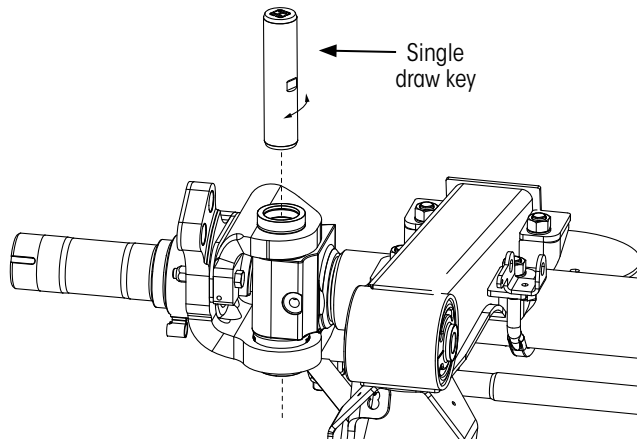

Figure 27: Single draw key king pin orientation

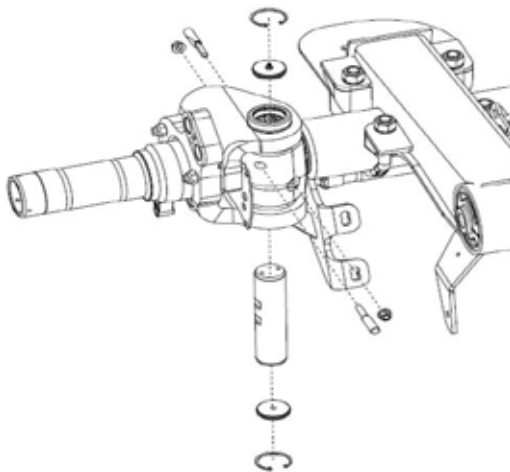

Figure 27 A: Dual draw key king pin orientation

5. **Orient** kingpin based on configurations shown in Figure 27 or 27A so the draw key notch is facing the draw key passage.

6. **Slide** kingpin into the housing assembly and at least half way into the axle end.

NOTICE If necessary, use a rubber hammer to knock kingpin into position.

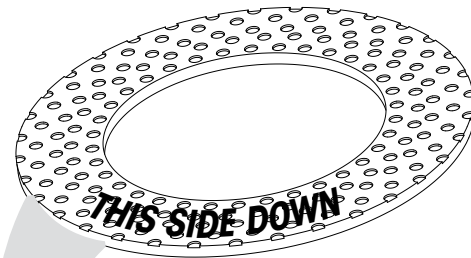

Figure 28: Thrust Washer

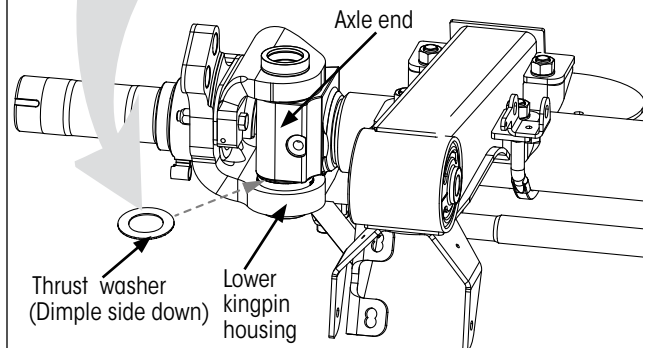

Figure 29: Installing thrust washer (Axle configuration may vary)

7. **Insert** thrust washer, dimples facing down (Figure 28), between lower kingpin housing assembly and axle end (Figure 29).

8. Continue to **insert** the kingpin until the draw key notch is properly aligned to the draw key passage in the axle end. **Reposition** the kingpin as needed.

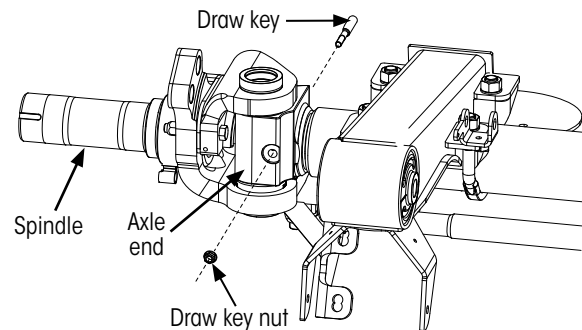

Figure 30: Installing draw key

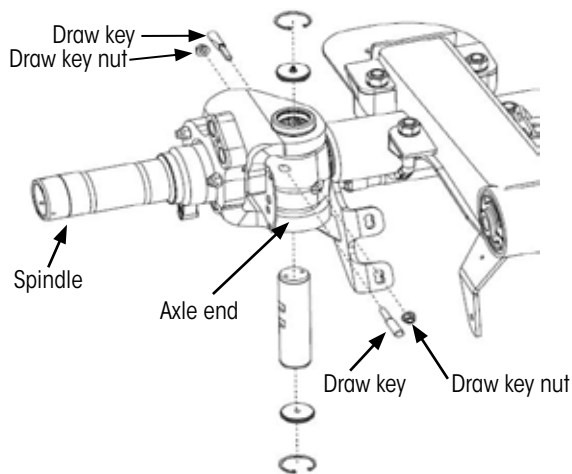

Figure 30 A: Installing dual draw key

9. Install the draw key by gently tapping it through the axle end draw key bore until at least six threads are showing. If necessary, partially remove and reorient the kingpin for a better fit.

NOTICE A misaligned kingpin or excessive force can cause damage to the draw key and/or kingpin during insertion.

10. Install the draw key nut (Figure 30 or 30 A) and tighten to the specified torque¹.

IMPORTANT: For proper installation, the draw key threads should be at least 1/2-inch past the nut. If not, remove the draw key and repeat Step 10 and Step 11.

11. Perform steering knuckle vertical end play check.



Figure 31: Checking steering knuckle vertical end play

- A. Turn the knuckle to the straight-ahead position.
- B. Affix a magnetic base dial indicator on the axle and place the tip of the dial indicator vertically on top of the steering knuckle (not on the grease cap) as shown in Figure 31.

¹ Refer to FASTENER TORQUE SPECIFICATIONS on page 21 for wrench sizes and a complete list of torque specifications.

- C. Set the dial indicator to "0" zero.
- D. Use one of the following methods to measure the vertical clearance:
 - i. Place a pry bar between the knuckle and top of the axle center. Pry the knuckle up and measure the vertical end play.
 - ii. Place a block of wood and a hydraulic jack under the bottom of the knuckle. Raise the knuckle until the pointer on the dial indicator stops.

NOTICE It may be necessary to drill a hole in the block of wood to avoid the grease fitting.

- E. Record the dial indicator reading, vertical end play must be between 0.008" and 0.030".
 - iii. If the reading is greater than 0.030" add shims (Figure 32) between the top of the axle and the bottom of the upper kingpin connection.

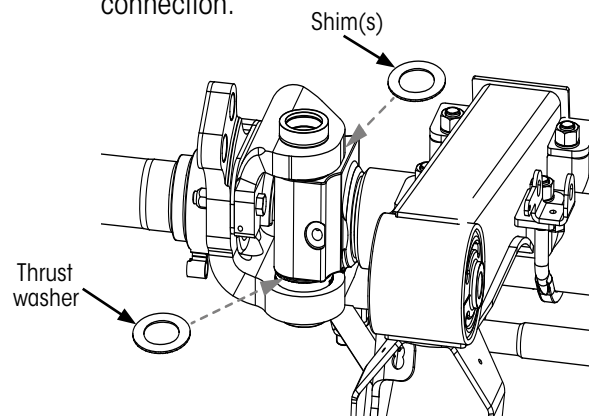

Figure 32: Installing shims (Axle configuration may vary)

INSTALLING KINGPIN CAPS

The original kingpin caps and snap rings were likely damaged during removal and must be replaced with new caps available in kingpin service kits.

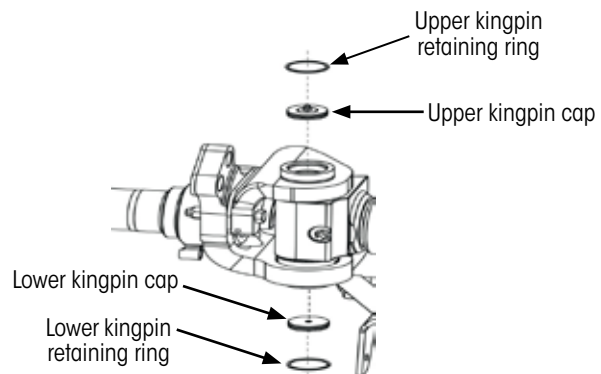

Figure 33: Installing kingpin cap assemblies (Axle configuration may vary)



1. Ensure all surfaces and grooves in the steer kingpin housing assemblies, top and bottom, are clear of debris and contaminants.
2. Install upper and lower kingpin cap assemblies (Figure 33) ensuring the O-rings are not damaged during assembly.

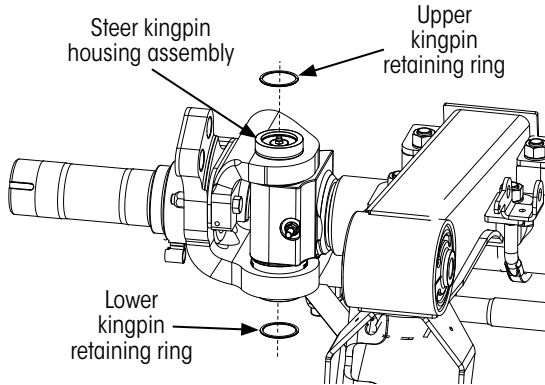

Figure 34: Installing kingpin retaining rings (Axle configuration may vary)

3. Install new retaining rings (Figure 34) snugly into inner groove of each kingpin housing assembly.
4. Install wheel-cut stop bolt and jam nut removed in step 7 on page 15.
5. If necessary, adjust wheel-cut stop bolt to the length previously recorded in step 6 on page 15,

NOTE: During reassembly, the bolt(s) must be installed to be the same length or readjusted. Refer to WHEEL-CUT ADJUSTMENT.

6. Tighten the jam nut to the specified torque¹.
7. Refer to SUSPENSION LUBRICATION on page 7 to inject grease into all steer kingpin housing assemblies.
8. Verify knuckle end play; refer to KINGPIN BUSHING INSPECTION on page 13.
 - A. If within tolerance, continue to the next step.
 - B. If not within tolerance, determine cause and make necessary repairs.
9. Install brake components, hub, drum and wheels. Refer to applicable wheel-end maintenance manual and L974 Drum Brake Maintenance Procedures for proper installation procedures.
10. Install tie rod and tie rod bracket refer to Reattach Tie Rod and Reinstall Tie Rod Bracket on page 11. Restore trailer to normal operating state.

¹ A complete list of torque values can be found at FASTENER TORQUE SPECIFICATIONS on page 21.

WHEEL-CUT ADJUSTMENT

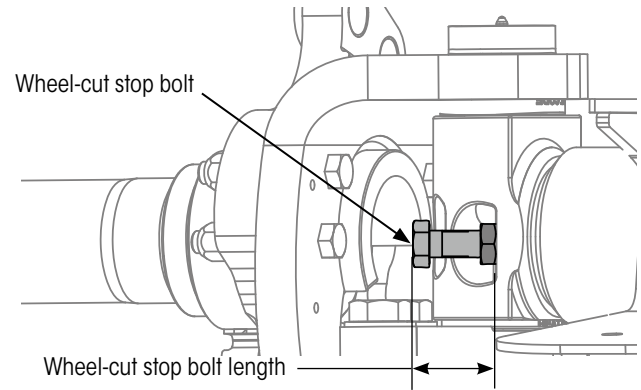

Figure 35: Adjustable wheel-cut stop bolts (Axle configuration may vary)

The maximum wheel-cut is set by adjusting the two wheel-cut stop bolts (Figure 35) on each end of the axle, rear side. These stop bolts are aligned to the knuckle for the purpose of limiting steer axle wheel-cut movement and prevent the wheels from contacting the trailer.

Wheel-cut was originally factory set according to trailer OEM specifications. Allowed tire clearance is listed in installation drawing² D-36237.

IMPORTANT: This is required for self-steer axles. Local regulations may exist which determine the wheel-cut angle.

1. Loosen stop bolt jam nut (Figure 35).

WHEEL-CUT (DEG)	STOP BOLT LENGTH (IN)
30.00	1.439
28.00	1.599
25.00	1.849
20.00	2.239
³ All values are nominal.	

Table 6: Wheel-cut Stop Bolt Setting
Suspensions produced before March 2024

WHEEL-CUT (DEG)	STOP BOLT LENGTH (IN)
30.00	1.063
28.00	1.172
25.00	1.341
20.00	1.634
⁴ All values are nominal.	

Table 6 A: Wheel-cut stop bolt setting
Suspensions produced after March 2024

² An installation drawing is provided with each CONNEX® ST suspension. Generic versions are listed in Hendrickson literature number T61001 and available online at www.hendrickson-intl.com/TrailerLit. Where duplication exists, refer to installation drawing.

2. Adjust each wheel-cut stop bolt length for the desired wheel-cut. If needed, refer to Table 6 or 6A. Dependent on suspension manufacturing date.
3. Tighten the locking jam nut to the specified torque¹.

BRAKE COMPONENTS

Brake components for self-steer axles are supported by the spider which is integrated into the knuckle design. For maintenance of CONNEX® ST drum brake components, refer to Hendrickson literature number [L974 Drum Brake Maintenance Procedures](#).

CAM TUBE

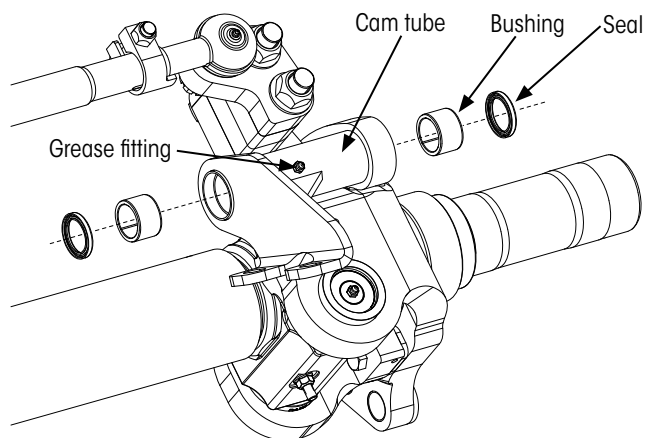

Figure 36: CONNEX® ST cam tube
(Axle configuration may vary)

The cam tube for CONNEX ST suspension systems is part of the knuckle weldment and cannot be replaced separately. Service includes inspection, lubrication ([Table 3 on page 5](#)) and, if needed, replacing bushings and seals. A service kit is available for replacing cam tube bushings and seals according to the procedure listed in Hendrickson literature number [L974 Drum Brake Maintenance Procedures](#).

NOTICE Replacing lubricant purges any collected moisture, contaminants and degraded lubricant. Continue to add grease until fresh grease is visible at the purge point.

APPENDIX A: TERMS AND DEFINITIONS

The following terms apply to Self-Steer Axles.

Camber The vertical inward or outward angle of the wheel as viewed from the front or rear of the vehicle.

Caster The angle of rotation of the kingpin (top tilting forward or rearward) parallel to the vertical center of the wheel and perpendicular to the road surface.

This angle is not adjustable. It is established during factory assembly of the axle/beam weldment.

Lock-straight The position where wheels (spindles) are locked into a straight position with the centerline parallel with the axle. If down, wheels must be in this position while the trailer moves in reverse direction.

Toe The angle at which, relative to forward motion, the leading edge of the wheels point inward (Toe-in, Y-X = positive value) or outward (Toe-out, Y-X = negative value) from the center line of the vehicle. The correct toe is important to minimize scrubbing of the tires. For checking and adjusting, refer to Hendrickson literature number [L579 Alignment Procedure](#).

Wheel-cut Expressed in degrees, wheel-cut is the maximum angle of the steer axle inner wheel when turning. See [WHEEL-CUT ADJUSTMENT](#) on page 19.

¹ A complete list of torque values can be found at [FASTENER TORQUE SPECIFICATIONS](#) on page 21.



APPENDIX B: FASTENER TORQUE SPECIFICATIONS

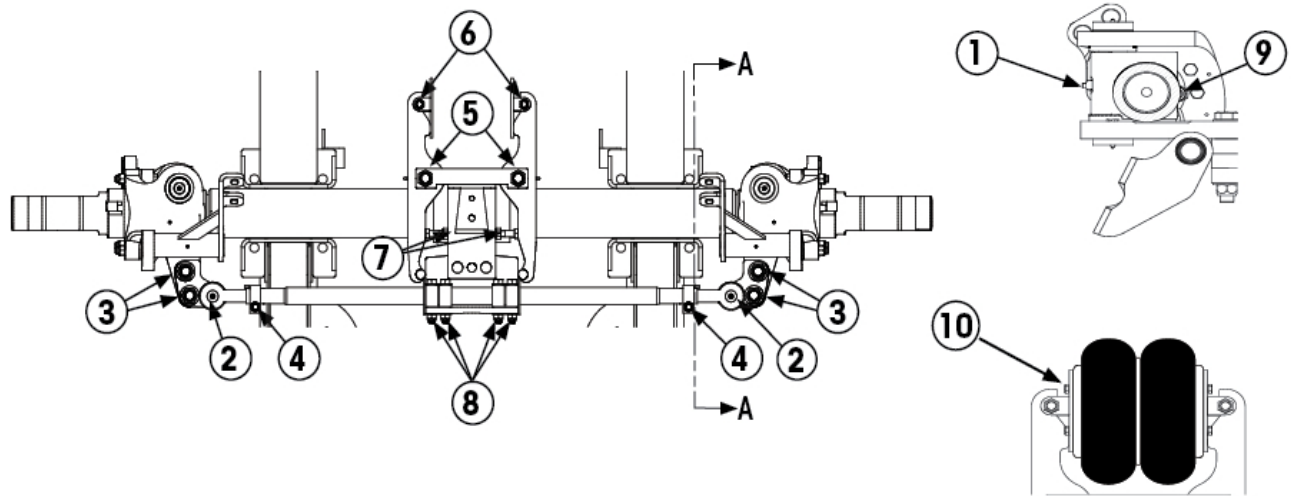

Figure 37: Self-steer axle fastener locations
(Axle configuration may vary)

ID ¹	FASTENER LOCATION	FASTENER	WRENCH / SOCKET SIZE	TORQUE		IMAGE ¹
				ft. lbs.	Nm	
1	Kingpin draw key	$\frac{7}{16}$ -20 UNF	$1\frac{1}{16}$ inch	30±3	40±3	Figure 20 and 20A, on page 14
2	Tie rod end castle nut (torque to specified value, then tighten to nearest cotter pin hole)	$\frac{7}{8}$ -14 UNF Castel nut	33mm	165±5 ²	225±5 ²	Figure 19 on page 14
3	Steering arm spacer bolts	1.0-8 x 8.0 large hex head bolt 1.0 flat washer (nut & bolt sides) 1.0-8 prevailing torque nut	1½ inch	680±10	920±10	
4	Tie rod end locking clamps	$\frac{5}{8}$ -11 x 3.0 large hex head bolt $\frac{5}{8}$ -11 prevailing torque nut	$1\frac{5}{16}$ inch	55±5 ³	75±5 ³	Figure 1 on page 5
5	Lock-straight arm assembly pivot bolts	1.0-8 x 5.0 large hex head bolt 1.0-8 prevailing torque nut	1½ inch	⁴	⁴	Figure 7 on page 8
6	Lock-straight actuator plate pivot bolts	$\frac{5}{8}$ -11 x 4.0 large hex head bolt $\frac{5}{8}$ -11 prevailing torque nut	$1\frac{5}{16}$ inch	⁴	⁴	Figure 7 on page 8
7	Lock-straight stop bolt and jam nut	$\frac{5}{8}$ -11	$1\frac{5}{16}$ inch	140±10 ³	190±10 ³	Figure 7 on page 8
8	Tie rod bracket locking clamp bolts	$\frac{5}{8}$ -11 x 4.0 large hex head bolt $\frac{5}{8}$ flat washer (nut & bolt sides) $\frac{5}{8}$ -11 prevailing torque nut	$1\frac{5}{16}$ inch	95±5 ³	130±5 ³	Figure 7 on page 8
9	Wheel-cut stop bolt and jam nut	$\frac{3}{4}$ -10 nut	1⅛ inch	140±10	190±10	Figure 35 on page 19
10	Lock-straight actuator mounting screws	$\frac{3}{8}$ -16	$\frac{9}{16}$ inch	30±5	40±5	Figure 8 on page 9
11	Pin lock chamber nut			41±2	56±2	

¹ Called out in Figure 34 and figure called out in last column.
² After torquing, advance to nearest cotter pin hole.
³ Tighten only after adjustments have been made.
⁴ Tighten only until nut seats up against bracket. Feature must rotate freely.

Table 7: Self-steer axle fastener torque specifications

Actual product performance may vary depending upon vehicle configuration, operation, service and other factors.

Call Hendrickson at 866.RIDEAIR (743.3247) for additional information.



www.hendrickson-intl.com

TRAILER COMMERCIAL VEHICLE SYSTEMS

2070 Industrial Place SE
Canton, OH 44707-2641 USA
866.RIDEAIR (743.3247)
Fax 800.696.4416

Hendrickson Canada

2825 Argenta Road, Unit #2-4
Mississauga, ON Canada L5N 8G6
800.668.5360
905.789.1030 • Fax 905.812-9423

Hendrickson Mexicana

Circuito El Marqués Sur #29
Parque Industrial El Marqués
Pob. El Colorado, Municipio El Marqués,
Querétaro, México C.P. 76246
+52 (442) 296.3600 • Fax +52 (442) 296.3601

T62001 Rev E 01-26 CN043547 01-18 ECN 30019

© 2018-2026 Hendrickson USA, L.L.C. All Rights Reserved. All trademarks shown are owned by Hendrickson USA, L.L.C., or one of its affiliates, in one or more countries. Information contained in this literature was accurate at the time of publication. Product changes may have been made after the copyright date that are not reflected.

Printed in United States of America