

This Print remains the property of Hendrickson. All information contained thereon is confidential. It is loaned, subject to return on demand and on express condition that it is not to be copied or used directly or indirectly for any purpose other than the purpose for which it has been loaned to you.

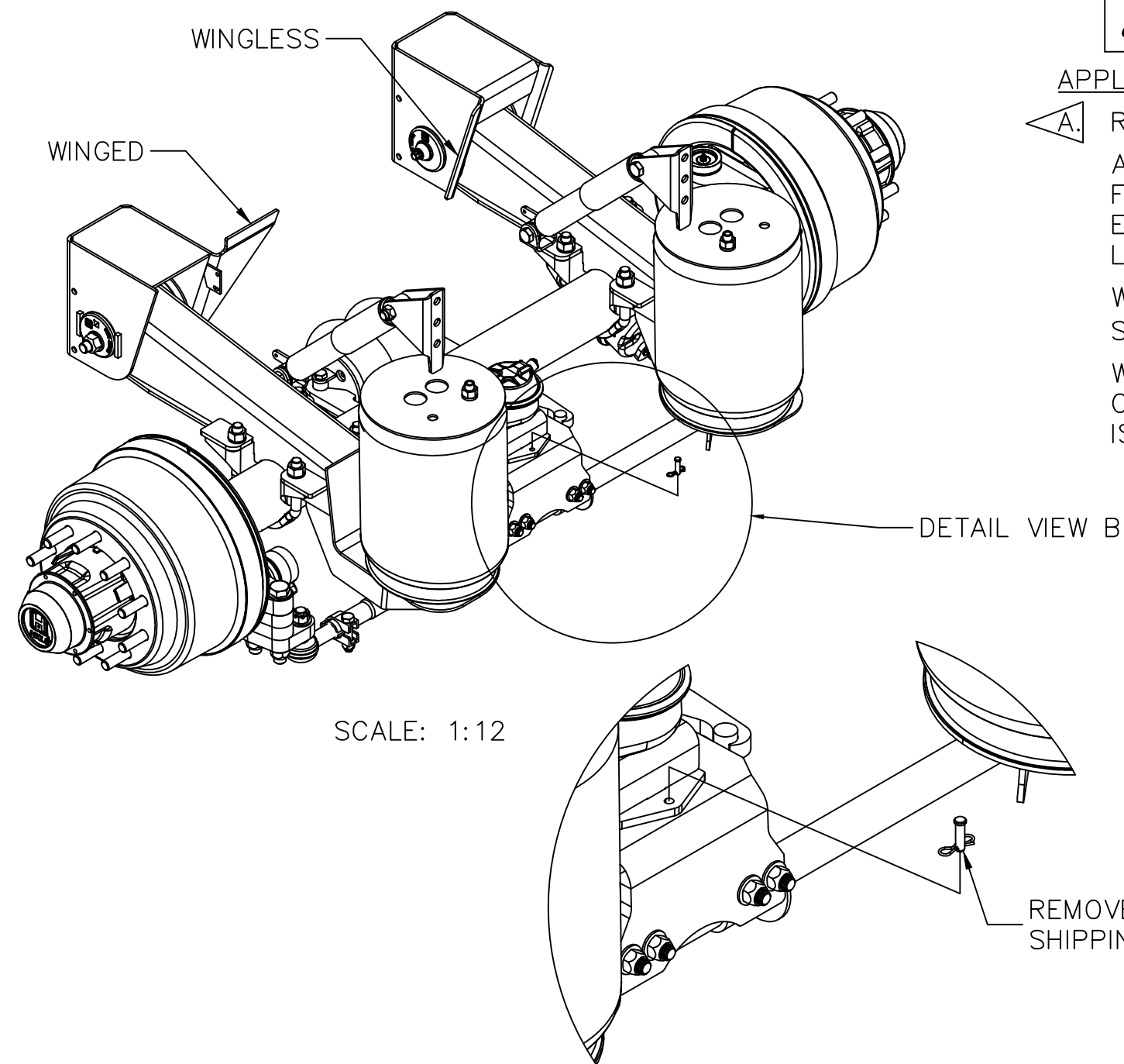
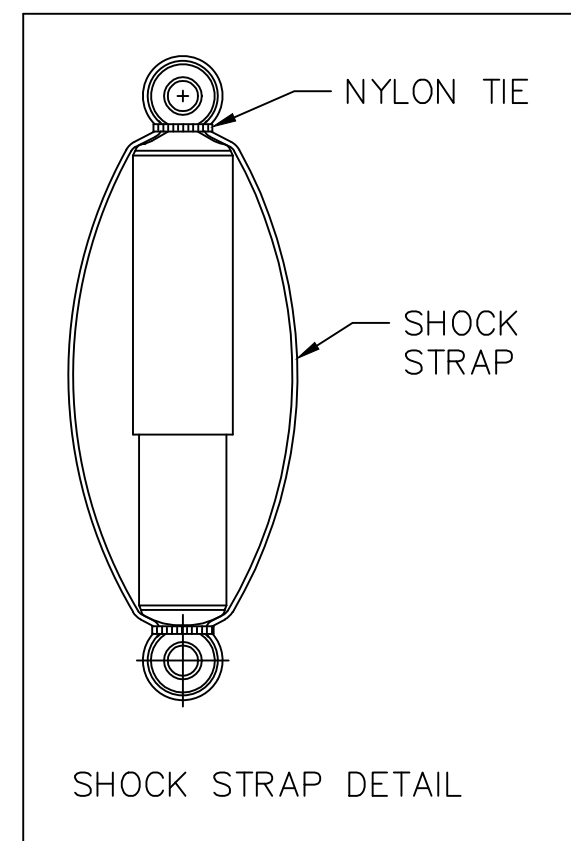

### CAUTION

#### APPLICATION RECOMMENDATIONS

**A** RIDE HEIGHT TOLERANCES MUST NOT BE EXCEEDED TO MAINTAIN PROPER CASTER ANGLE FOR OPTIMUM OPERATIONAL PERFORMANCE. ALL SUSPENSIONS ON A TRAILER SHOULD BE AT DESIGNED RIDE HEIGHT WHEN THE TRAILER IS LOADED. TRAILERS WITH FLEXIBLE FRAMES REQUIRE SPECIAL ATTENTION TO MAKE SURE THE SUSPENSIONS OPERATE WITHIN THE APPROVED RIDE HEIGHT RANGE IN EMPTY AND LOADED CONDITIONS. OPERATION OUTSIDE OF THE RIDE HEIGHT RANGE CAN REDUCE RIDE QUALITY, SHORTEN SUSPENSION LIFE, AND MAY RESULT IN UNEQUAL LOADING OF THE AXLES.

WHEN AIR IS DUMPED ON LEVEL GROUND ALL PRIMARY SUSPENSIONS MUST REACH BUMPER CONTACT HEIGHT BEFORE THE CONNEX ST SUSPENSION REACHES ITS BUMPER CONTACT HEIGHT.

WHEEL-CUT IS PRESET BY HENDRICKSON PER CUSTOMERS REQUEST. IT IS THE INSTALLERS RESPONSIBILITY TO MAINTAIN NECESSARY CLEARANCES WITH SUSPENSION COMPONENTS AND TRAILER FRAME. THIS RESPONSIBILITY INCLUDES IF WHEEL-CUT STOP BOLT SETTING IS CHANGED FROM PRESET VALUE.

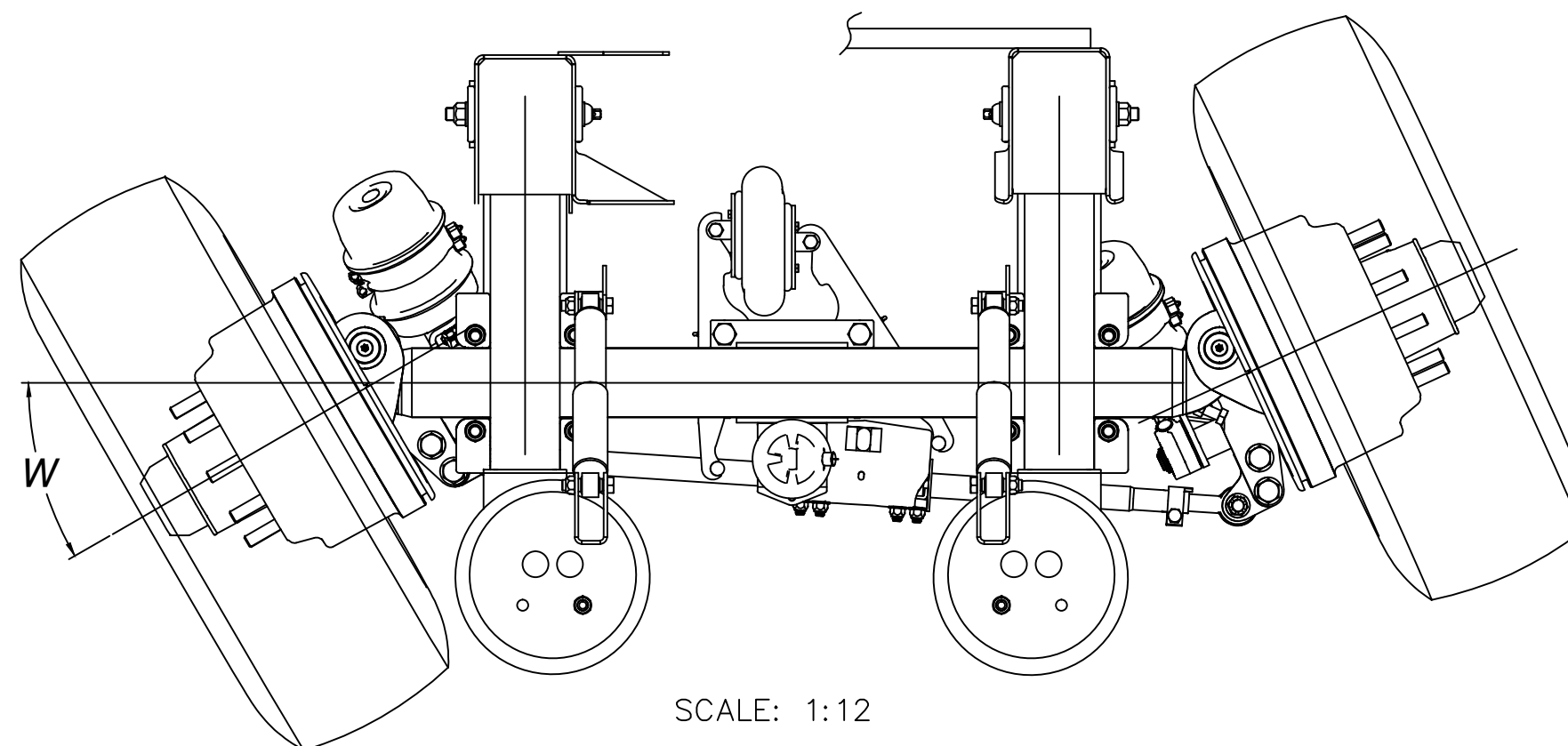

#### NOTES:

- SEE L577 INSTALLATION INSTRUCTIONS FOR INFORMATION ON ASSEMBLY AND WELDING PROCEDURE.
- SEE L579 FOR ALIGNMENT PROCEDURE.
- SEE PAGE 7 FOR C-CHANNEL AND FRAME BRACKET BRACE MOUNTING REQUIREMENTS.
- SEE PAGE 5 FOR TRAILER FRAME CROSSMEMBER LOCATIONS AND MOUNTING DETAILS. ACTUAL SIZE AND SHAPE MAY VARY WITH TRAILER DESIGN. IT IS THE RESPONSIBILITY OF THE INSTALLER TO ENSURE STRUCTURAL ADEQUACY OF THE TRAILER FRAME.
- SEE PAGE 6 & 7 FOR BOLT-ON SUSPENSION MOUNTING REQUIREMENTS.
- SUSPENSION & AXLE CAPACITY: 25,000 LBS. AT GROUND. CAPACITY RATINGS OF BRAKES, TIRES, WHEELS, ETC. MAY LIMIT THE OVERALL CAPACITY OF THE SYSTEM.
- SEE PAGE 3 FOR TABULATED DIMENSIONS.

### CAUTION

#### CLEARANCE SPECIFICATIONS:

- 1.0 INCH MINIMUM REQUIRED BETWEEN TOP OF TIRE AND BOTTOM OF TRAILER STRUCTURE WHEN AXLE IS AT FULL JOUNCE.
- 2.0 INCHES MINIMUM REQUIRED BETWEEN INSIDE OF TIRE AND TRAILER STRUCTURE FOR LATERAL MOVEMENT.
- 1.0 INCH MINIMUM CLEARANCE MUST BE MAINTAINED AROUND AIR SPRING WHEN IT IS AT MAXIMUM DIAMETER.

DETAIL VIEW B  
SCALE: 1:6

REMOVE & DISCARD SHIPPING PIN

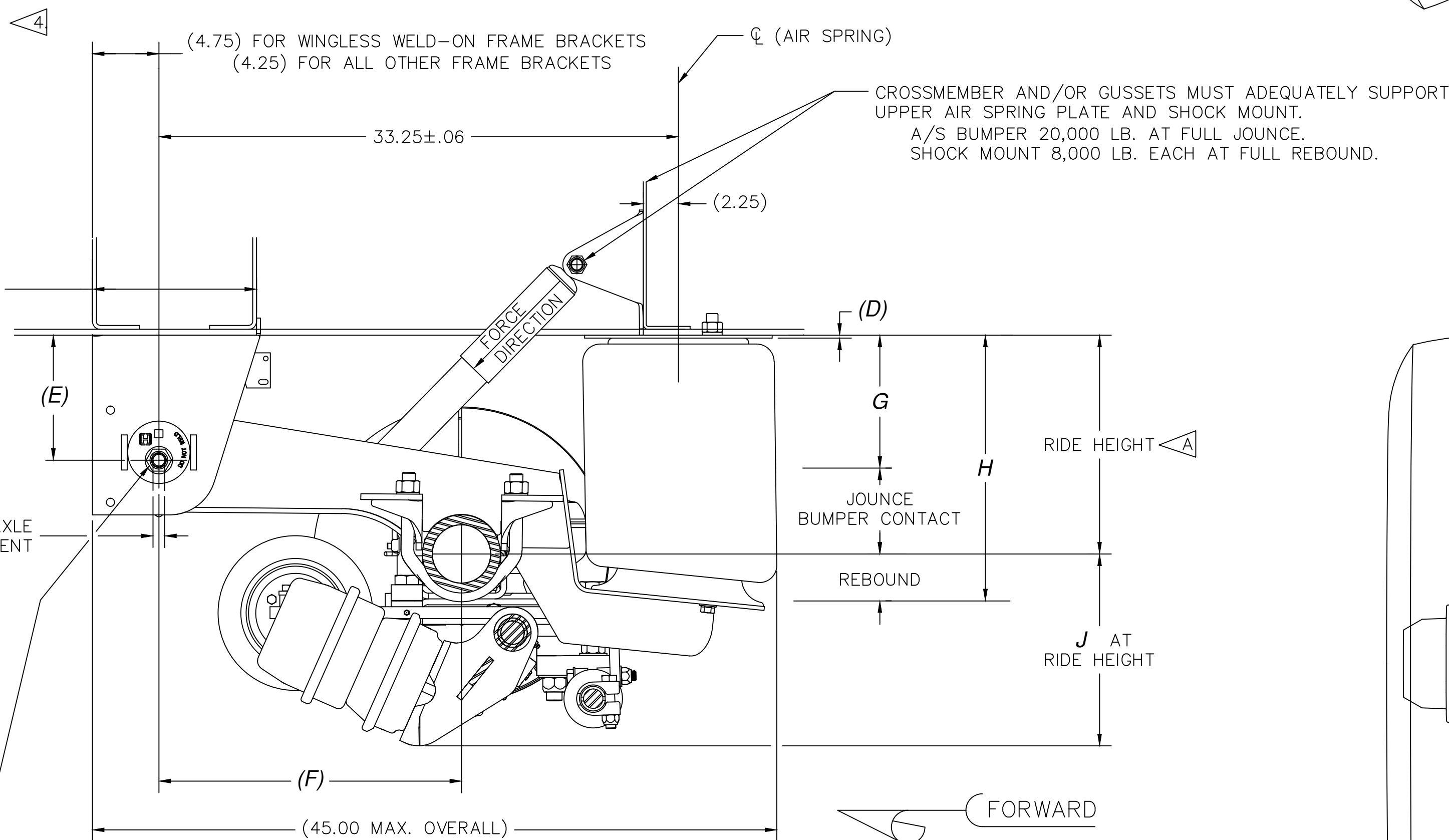

SECTION A-A

AFTER FINAL AXLE ALIGNMENT, TIGHTEN UNTIL SHEAR HEAD SEPARATES AS SHOWN BELOW.

TORQUE SPECIFICATIONS		
DESCRIPTION	SIZE	TORQUE (FT LB)
SHOCK BOLTS	3/4-10	210-235
AIR SPRING NUTS, UPPER	3/4-16	80-100
AIR SPRING BOLTS, LOWER	1/2-13	40-50
WHEEL CUT STOP BOLT, JAM NUT	3/4-10	125-150*
TIE ROD END CLAMPS	5/8-11	50-60*
LS ADJUSTER JAM NUT	5/8-11	125-150*
LS CENTER PLATE CLAMP BOLTS	5/8-11	90-100*

\* INDICATES INSTALLED BY HENDRICKSON. TORQUE IS FOR REFERENCE IF RE-TORQUE IS REQUIRED DURING ALIGNMENT PROCEDURES.

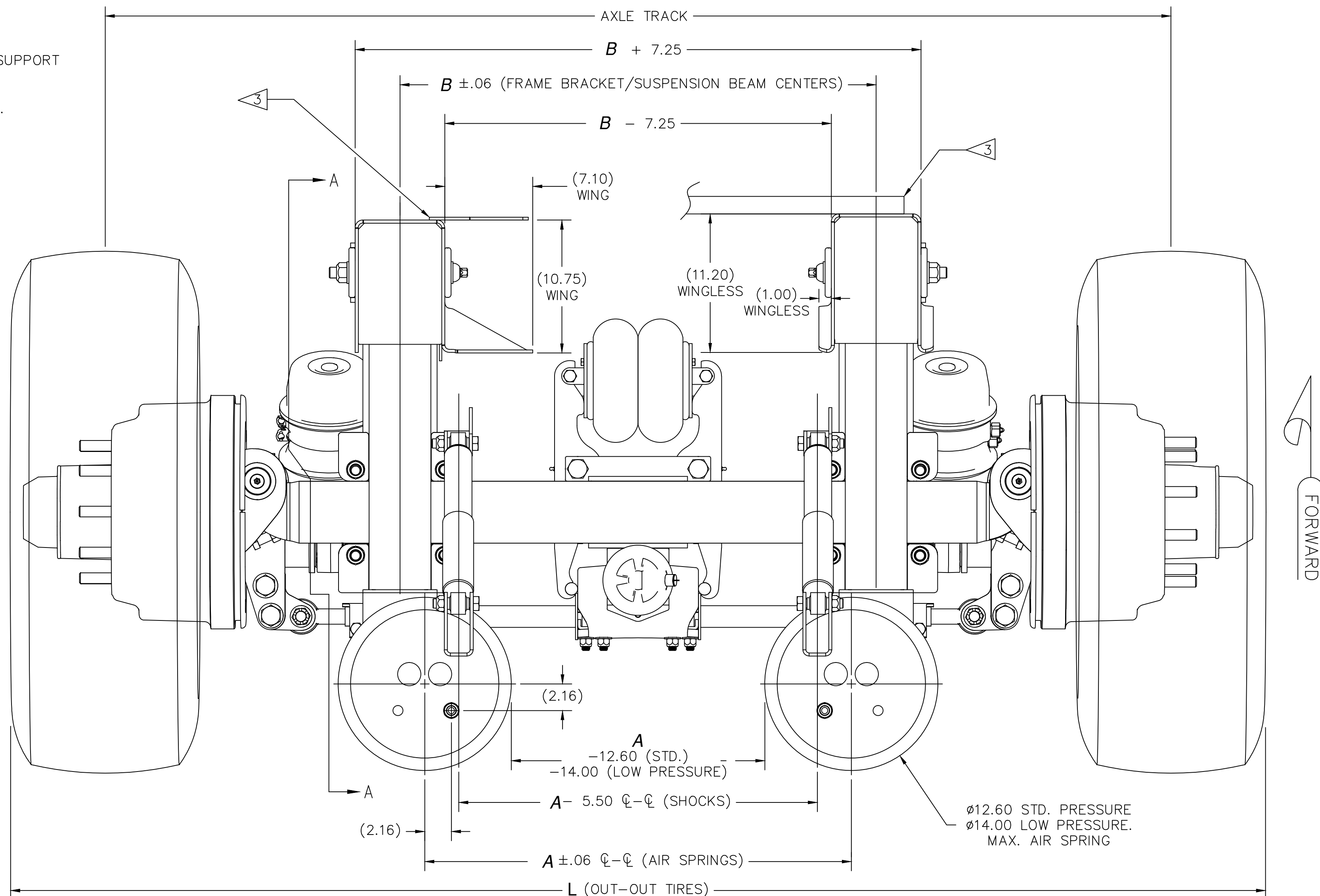

GROUND CLEARANCE	
TO CALCULATE GROUND CLEARANCE, SUBTRACT J FROM LOADED TIRE RADIUS.	
RIDE HEIGHT	J
13.0-19.0	12.22

**HENDRICKSON**

TRAILER COMMERCIAL VEHICLE SYSTEMS  
2070 INDUSTRIAL PLACE S.E., CANTON, OH 44707-2600 U.S.A.

TOLERANCES ARE:	DIMENSIONS ARE:	UNLESS OTHERWISE NOTED:
.X: ±	INCHES	7 043125
.XX: ±		6 34501
.XXX: ±		5 33407
ANGULAR: ±		4 31111

SLB	DATE	BY	DATE	APP'D BY	DATE
02-05-24	01/05/21	J. HOFER	07/20/20	C. RADCLIFF	05-15-18

7-9-15  
K. ERDMANN

CONNEX® ST  
INSTALLATION DRAWING

SCALE	SIZE	PAGE
1:6	D	1 OF 8

DRAWING No. D-36237

P  
PRODUCTION

This Print remains the property of Hendrickson. All information contained thereon is confidential. It is loaned, subject to return on demand and on express condition that it is not to be copied or used directly or indirectly for any purpose other than the purpose for which it has been loaned to you.

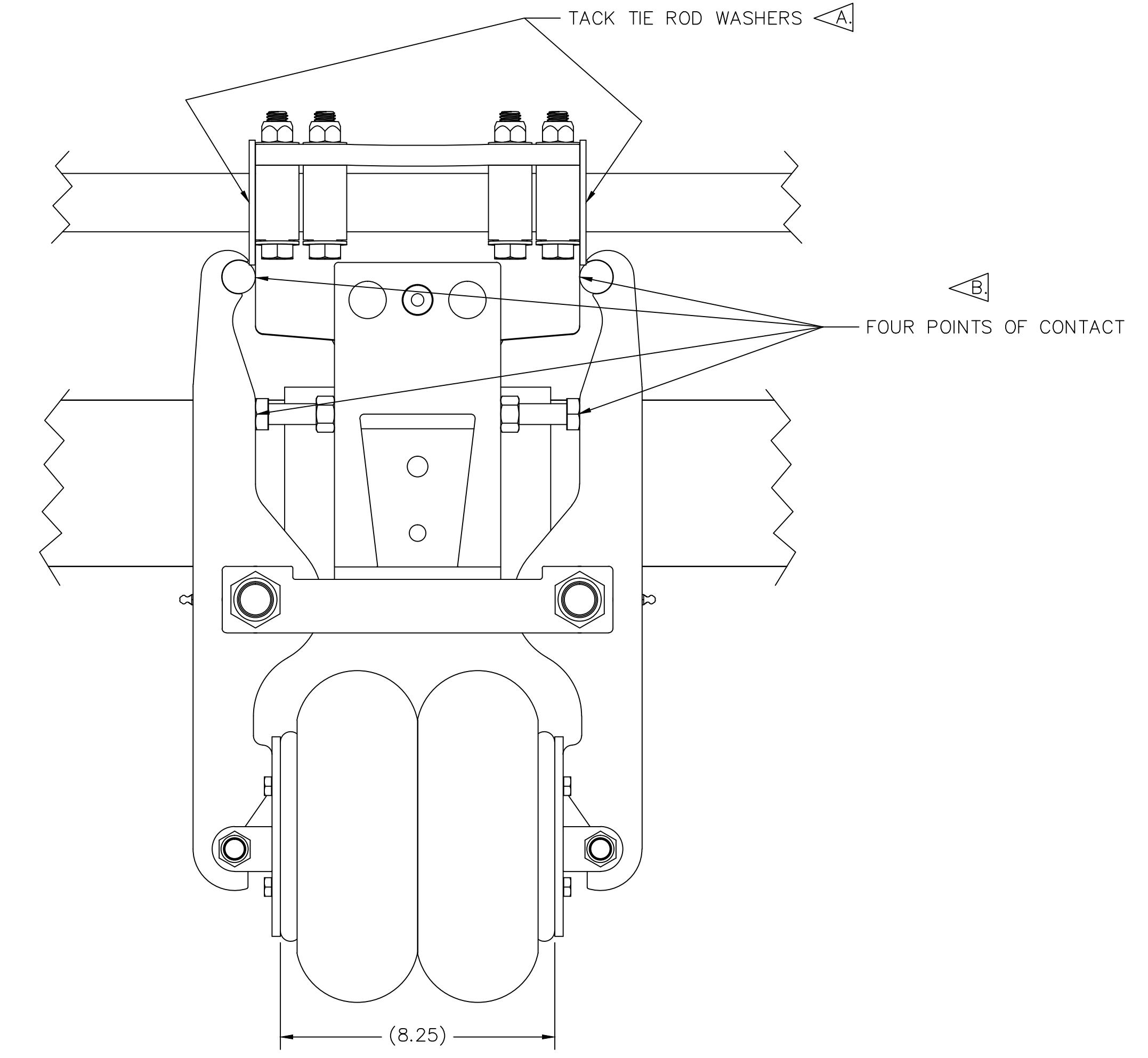
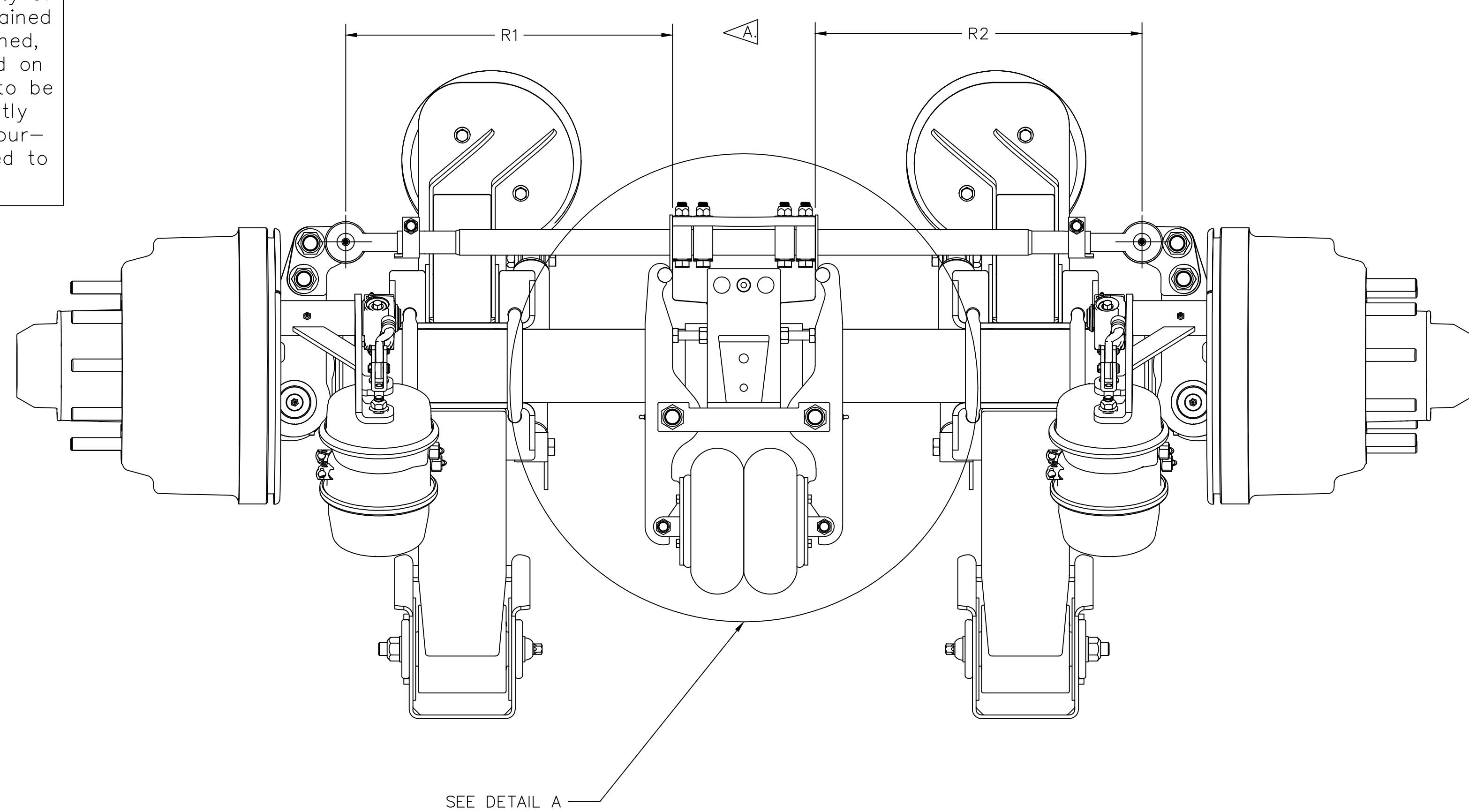

### RECOMMENDED PLUMBING FOR LOCK STRAIGHT MECHANISM

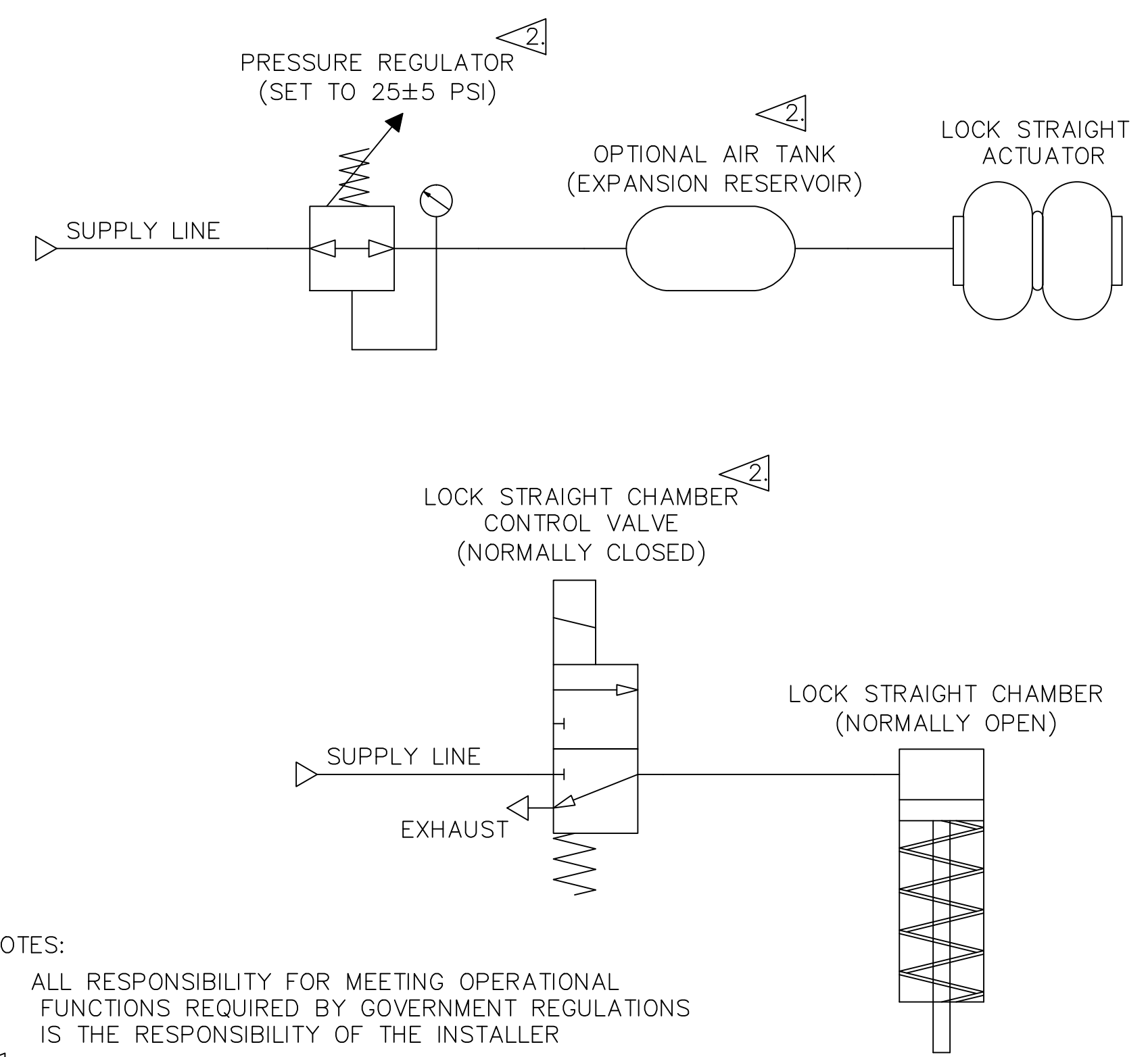

NOTES:  
1. ALL RESPONSIBILITY FOR MEETING OPERATIONAL FUNCTIONS REQUIRED BY GOVERNMENT REGULATIONS IS THE RESPONSIBILITY OF THE INSTALLER  
2. COMPONENTS NOT PROVIDED BY HENDRICKSON.

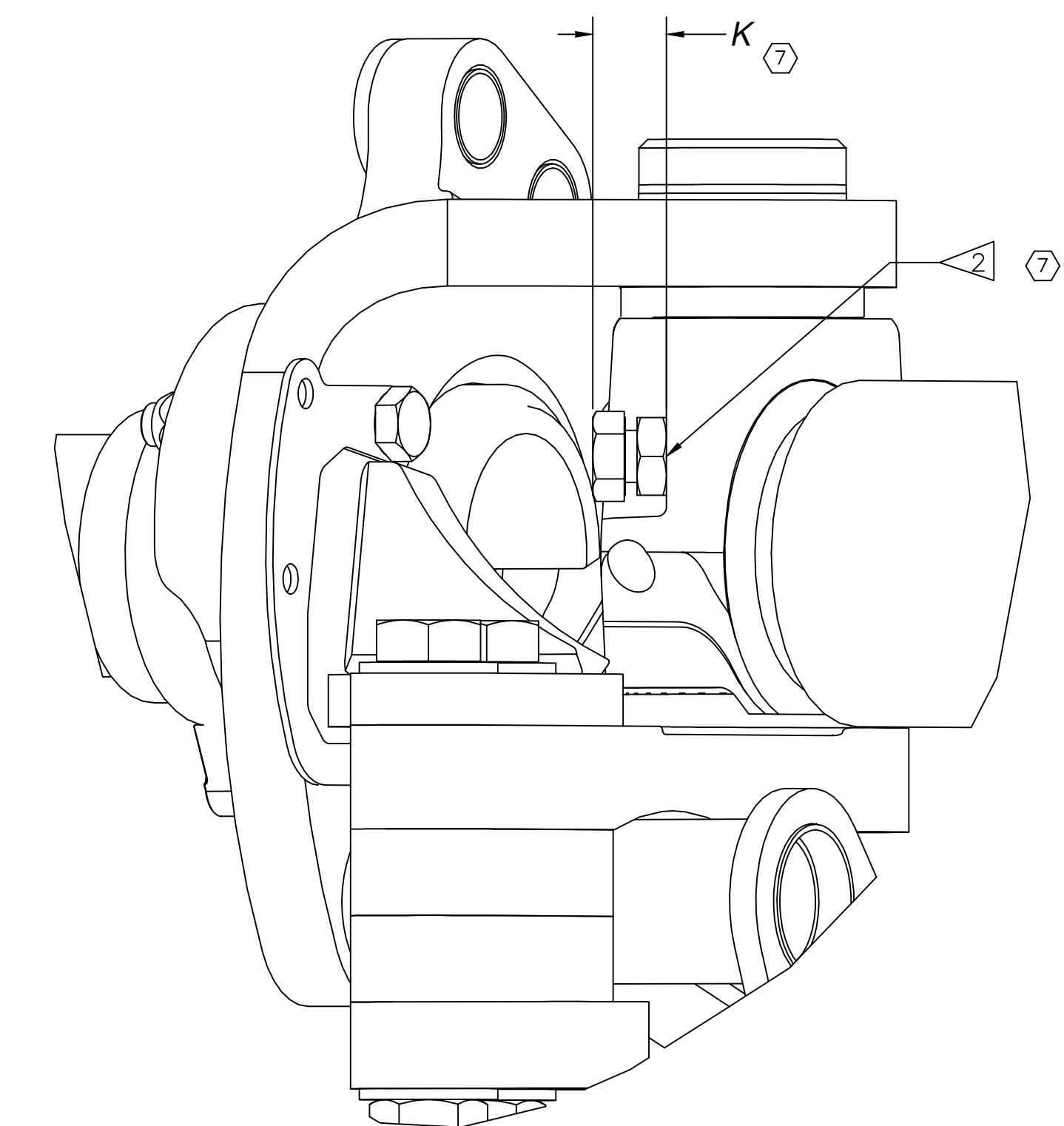

WHEEL CUT STOP BOLT SETTING DETAIL  
SCALE: 1:3

WHEEL CUT STOP BOLT SETTING		
WHEEL CUT		DIM K
30.00°	+ .50° - .00°	⑦ 1.063 <sup>+</sup> .000 - .032
28.00°	+ .50° - .00°	⑦ 1.172 <sup>+</sup> .000 - .028
25.00°	+ .50° - .00°	⑦ 1.341 <sup>+</sup> .000 - .030
20.00°	+ .50° - .00°	⑦ 1.634 <sup>+</sup> .000 - .031

**IMPORTANT**

1. STOP BOLT SETTINGS IN TABLE ARE FOR DUAL DRAW KEY KINGPIN SETUPS. FOR SINGLE DRAW KEY KINGPIN SETUPS PLEASE CONTACT HENDRICKSON.

2. WHEEL-CUT IS PRESET BY HENDRICKSON PER CUSTOMERS REQUEST. IT IS THE INSTALLERS RESPONSIBILITY TO MAINTAIN NECESSARY CLEARANCES WITH SUSPENSION COMPONENTS AND TRAILER FRAME. THE RESPONSIBILITY INCLUDES IF WHEEL-CUT STOP BOLT SETTING IS CHANGED FROM PRESET VALUE.

NOTES:  
1. SEE L579 FOR ALIGNMENT PROCEDURE.  
2. SEE PAGE 1 FOR TORQUE SPECIFICATIONS OF FASTENERS.

### IMPORTANT

SELF STEER AXLE VERIFICATION CHECKLIST:

A. VERIFY TIE ROD CENTER BRACKET LOCATION R1=R2 WITHIN ±.09. IF ADJUSTMENT IS NOT REQUIRED THEN TACK TIE ROD WASHERS IN PLACE. IF ADJUSTMENT IS NEEDED LOOSEN CENTER PLATE CLAMP BOLTS SO ADJUSTMENT CAN BE MADE. WHEN R1=R2 WITHIN ±.09 TORQUE CLAMP BOLTS PER CHART BB ON PG. 1 AND TACK TIE ROD WASHERS IN PLACE.

B. VERIFY 4 POINTS OF CONTACT ON LOCK STRAIGHT MECHANISM. TO VERIFY AND ADJUST REFER TO L579.

C. TOE IS PRESET BY HENDRICKSON. DURING FINAL ALIGNMENT TOE SHOULD BE VERIFIED. REFER TO L579 TO TOE SETTINGS AND ADJUSTMENTS.

This Print remains the property of Hendrickson. All information contained thereon is confidential. It is loaned, subject to return on demand and on express condition that it is not to be copied or used directly or indirectly for any purpose other than the purpose for which it has been loaned to you.

CONNEX ST AXLE ASSEMBLY (HP)														
WHEEL CONFIGURATION	SINGLE											DUAL		
WHEEL MATERIAL	ALUMINUM											STEEL		
WHEEL OFFSET	.56 (OUTSET)							0.00 (OUTSET)*				0.00 (EFFECTIVE)		
WHEEL SIZE	12.25X22.5							14.00X22.5				8.25X22.5	8.25X24.5	
TIRE SIZE	385/65R22.5			425/65R22.5				455/55R22.5**				11R22.5	11R24.5	
AXLE TRACK	80.0	85.0	86.0	77.5	83.5	84.0	85.0	77.5	83.5	84.0	85.0	77.5		
L (TIRE OUT-TO-OUT)	95.6	100.5	101.5	94.5	100.6	101.1	102.1	94.6	100.6	101.1	102.1	102.2		
B (FRAME BRACKET/SUSP. BEAM CENTERS)	32.5	37.5	38.5	39.5	30.0	36.0	36.5	37.5	30.0	36.0	36.5	37.5	28.5	30.0
A (AIR SPRING CENTERS)	28.5	33.5	34.5	35.5	26.0	32.0	32.5	33.5	26.0	32.0	32.5	33.5	24.5	26.0
W <sup>o</sup> (MAX WHEELCUT)	30.0	30.0	30.0	28.0	30.0	30.0	30.0	30.0	28.0	28.0	28.0	28.0	20.0	
AXLE WEIGHT (LB)	725	740	743		716	735	736	740	716	735	736	740	716	

\* FOR 1.00 WHEEL OUTSET MOUNTING ADD 2.0 TO DIM. L

\*\* FOR 445/50R22.5 SUBTRACT .7 FROM DIM. L

**NOTES:**

- SUSPENSION WEIGHT INCLUDES SUSPENSION COMPONENTS ONLY. WEIGHT REFLECTS: CXSL STANDARD BEAMS, STANDARD A/S SHOCK MOUNT/SPACER, WINGED FRAME BRACKETS, STANDARD SHOCKS W/OUT SHOCK STRAP KIT, AND STANDARD HARDWARE.
- FOR AXLE WEIGHTS SEE TABLE "CONNEX ST AXLE ASSEMBLY (HP)" ON THIS DRAWING. AXLE WEIGHTS INCLUDES BRAKE COMPONENTS LESS BRAKE CHAMBERS AND SLACK ADJUSTERS.
- TOTAL WEIGHT = SUSP. WEIGHT + AXLE WEIGHT + FRAME BRACKET BRACING WEIGHT\*\*  
 \*\*IF WINGLESS FRAME BRACKET SEE ADDITIONAL WEIGHT FOR WINGLESS FRAME BRACKET TABLE  
 \*\*IF UBL OPTION IS INCLUDED ADD 70.98 LB TO TOTAL WEIGHT

4. JOUNCE AND REBOUND DIMENSIONS CHANGE AS THE RIDE HEIGHT CHANGES FROM THE NOMINAL POSITION.

5. DIMENSIONS "G" & "H" WILL REMAIN CONSTANT REGARDLESS OF RIDE HEIGHT VARIATION FROM NOMINAL POSITION.  
 RIDE HEIGHT - JOUNCE = "G"  
 RIDE HEIGHT + REBOUND = "H"

**CAUTION**

**APPLICATION RECOMMENDATIONS**

A. RIDE HEIGHT TOLERANCES MUST NOT BE EXCEEDED TO MAINTAIN PROPER STEER CASTER ANGLE FOR OPTIMUM OPERATIONAL PERFORMANCE.

ALL SUSPENSIONS ON A TRAILER SHOULD BE AT DESIGNED RIDE HEIGHT WHEN THE TRAILER IS LOADED. TRAILERS WITH FLEXIBLE FRAMES REQUIRE SPECIAL ATTENTION TO MAKE SURE THE SUSPENSIONS OPERATE WITHIN THE APPROVED RIDE HEIGHT RANGE IN EMPTY AND LOADED CONDITIONS. OPERATION OUTSIDE OF THE RIDE HEIGHT RANGE CAN REDUCE RIDE QUALITY, SHORTEN SUSPENSION LIFE, AND MAY RESULT IN UNEQUAL LOADING OF THE AXLES.

WHEN AIR IS DUMPED ON LEVEL GROUND ALL PRIMARY SUSPENSIONS MUST REACH BUMPER CONTACT HEIGHT BEFORE THE CONNEX ST SUSPENSION REACHES IT'S BUMPER CONTACT HEIGHT.

WHEEL-CUT IS PRESET BY HENDRICKSON PER CUSTOMERS' REQUEST. IT IS THE INSTALLERS RESPONSIBILITY TO MAINTAIN NECESSARY CLEARANCES WITH SUSPENSION COMPONENTS AND TRAILER FRAME. THIS RESPONSIBILITY INCLUDES IF WHEEL-CUT STOP BOLT SETTING IS CHANGED FROM PRESET VALUE.

STANDARD TRAVEL DIMENSIONS FROM PAGE 1													
	RIDE HEIGHT	JOUNCE	REBOUND	BUMPER CONTACT	D	E	F	G	H	RIDE HEIGHT TOLERANCE LIMITS		SUSP. WEIGHT (LB)	
										MIN.	MAX.		
WELD-ON REAR UPPER SHOCK MOUNT	13.0	5.0	4.2	4.4	.19	8.0	19.36	8.0	17.2	12.0	13.5	338	
	14.0	6.0	3.2	5.4	.19	8.0	19.36	8.0	17.2	13.0	14.5	338	
	15.0	6.5	3.1	5.9	1.00	8.0	19.02	8.5	18.1	14.0	15.5	341	
	16.0	6.1	3.0	5.5	2.00	10.0	19.36	9.9	19.0	15.0	16.5	352	
	17.0	6.5	3.1	5.9	3.00	10.0	19.02	10.5	20.1	16.0	17.5	356	
	18.0	6.1	3.0	5.5	4.00	12.0	19.36	11.9	21.0	17.0	18.5	367	
	19.0	6.5	3.1	5.9	5.00	12.0	19.02	12.5	22.1	18.0	19.5	370	
BOLT-ON REAR UPPER SHOCK MOUNT	13.0	4.9	4.2	4.4	.25	8.00	19.36	8.1	17.2	12.0	13.5	365	
	14.0	5.9	3.2	5.4	.25	8.00	19.36	8.1	17.2	13.0	14.5	365	
	15.0	6.4	3.3	5.8	1.19	8.00	19.02	8.6	18.3	14.0	15.5	367	
	16.0	6.0	3.2	5.4	2.19	10.00	19.36	10.0	19.2	15.0	16.5	379	
	17.0	6.4	3.3	5.8	3.19	10.00	19.02	10.6	20.3	16.0	17.5	382	
	18.0	6.0	3.2	5.4	4.19	12.00	19.36	12.0	21.2	17.0	18.5	404	
	19.0	6.4	3.3	5.8	5.19	12.00	19.02	12.6	22.3	18.0	19.5	407	

WEIGHT FOR FRAME BRACKET BRACING												
C-CHANNEL	STANDARD C-CHANNEL		BOLT-ON C-CHANNEL W/STRUTS								FR BKT GUSSET (WINGED WELD-ON ONLY)	
B (FRAME BRACKET/SUSP. BEAM CENTERS)	28.5-32.5	36.0-39.5	28.5	30.0	32.5	36.0	36.5	37.5	38.5	39.5	ALL	
FR BKT BRACING WEIGHT (LB)	11.80	14.00	12.62	13.07	13.81	15.30	15.45	15.75	16.04	16.34	6.32	

ADDITIONAL WEIGHT FOR WINGLESS FR BKT			
RIDE HEIGHT	13.0-15.0	16.0-17.0	18.0-19.0
WEIGHT (LB)	1.67	9.33	8.46

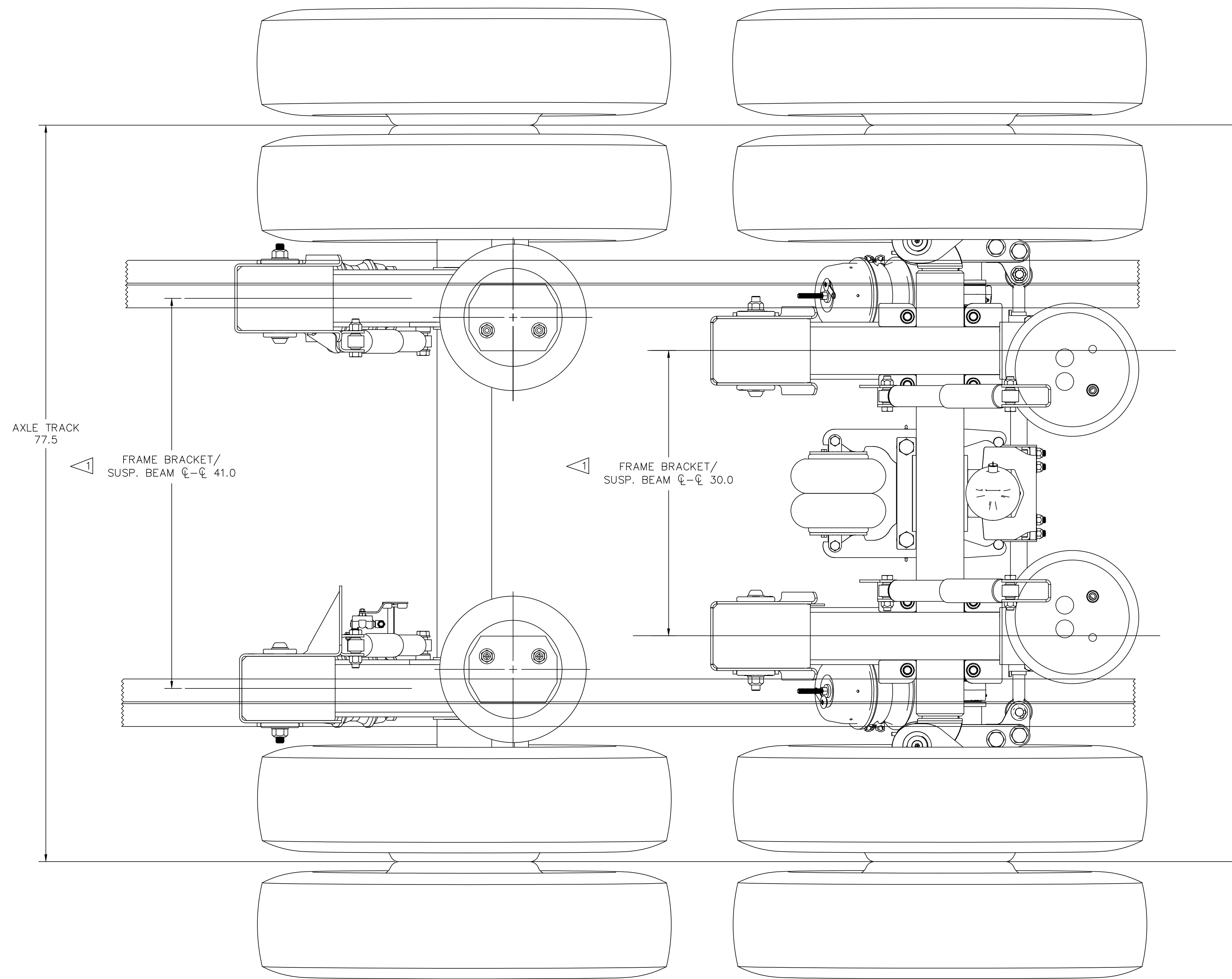

**IMPORTANT**

NOTES:

- 1. SUSPENSION BEAM CENTER REQUIRED FOR CONNEX ST ARE NOT THE SAME AS IT IS FOR OTHER INTRAAX® OR HT® SERIES PRODUCTS AT THE SAME AXLE TRACK.
- 2. SEE PAGE 2 FOR AVAILABLE AXLE TRACKS AND SUSPENSION BEAM CENTERS FOR CONNEX ST.

EXAMPLE:  
77.5 AXLE TRACK INTRAAX® PAIRED WITH A 77.5 AXLE TRACK CONNEX ST

This Print remains the property of Hendrickson. All information contained thereon is confidential. It is loaned, subject to return on demand and on express condition that it is not to be copied or used directly or indirectly for any purpose other than the purpose for which it has been loaned to you.

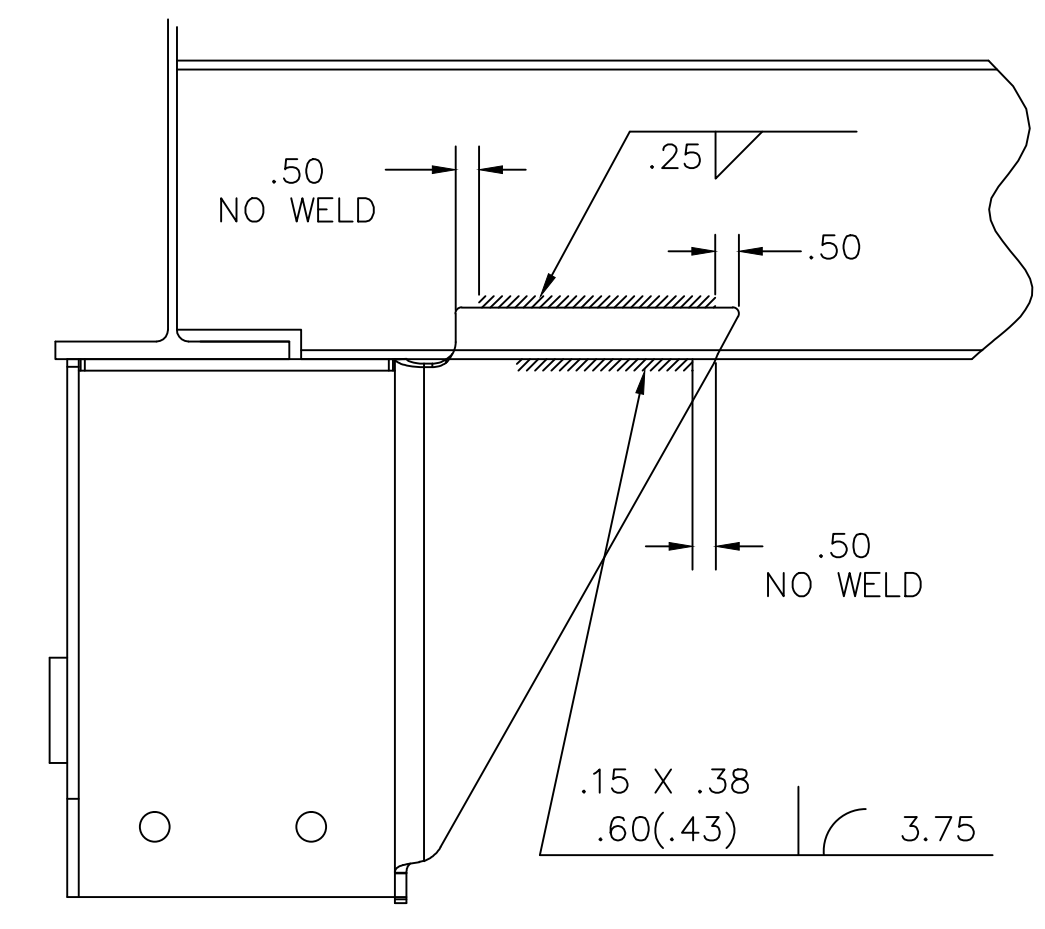
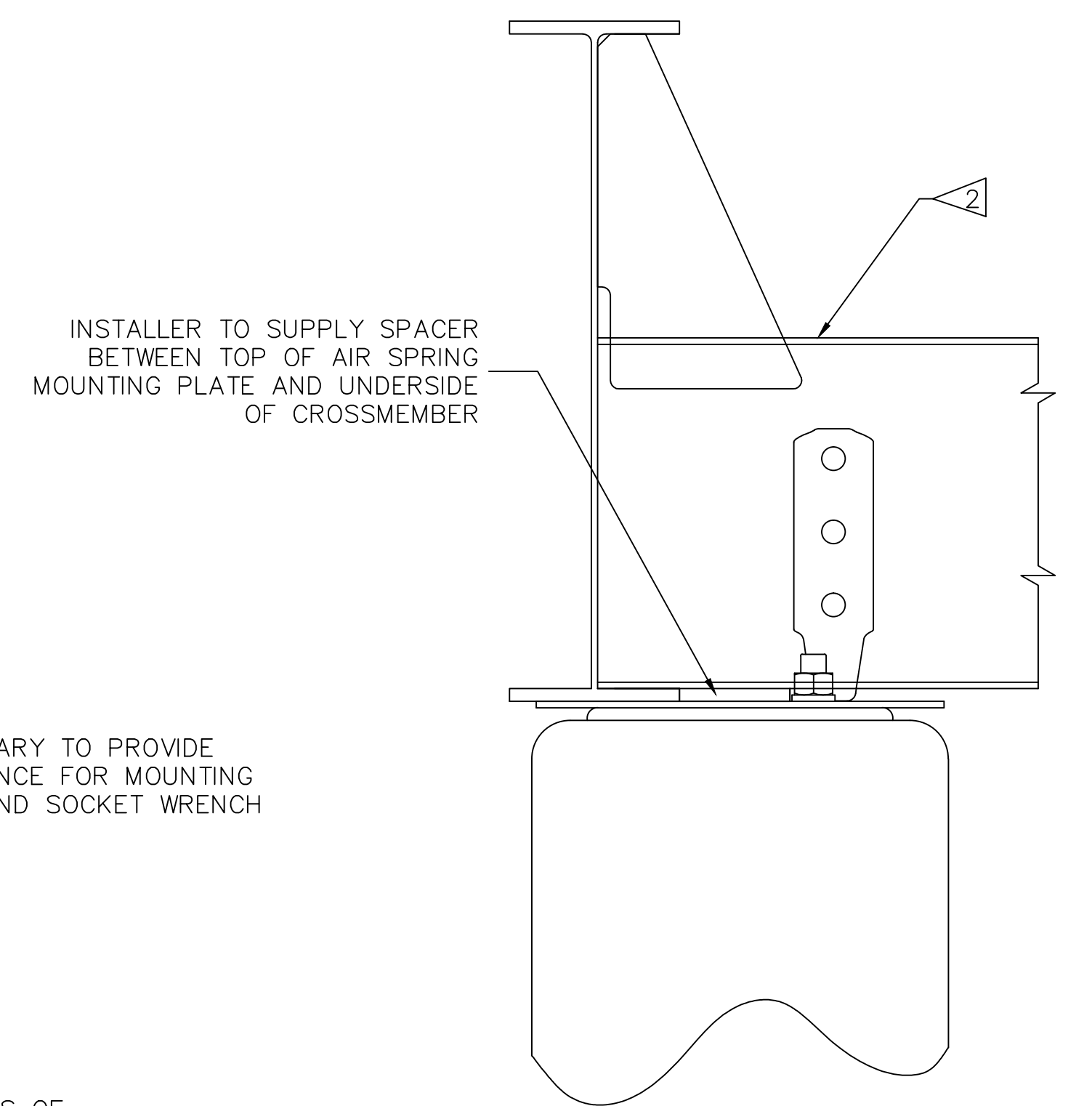
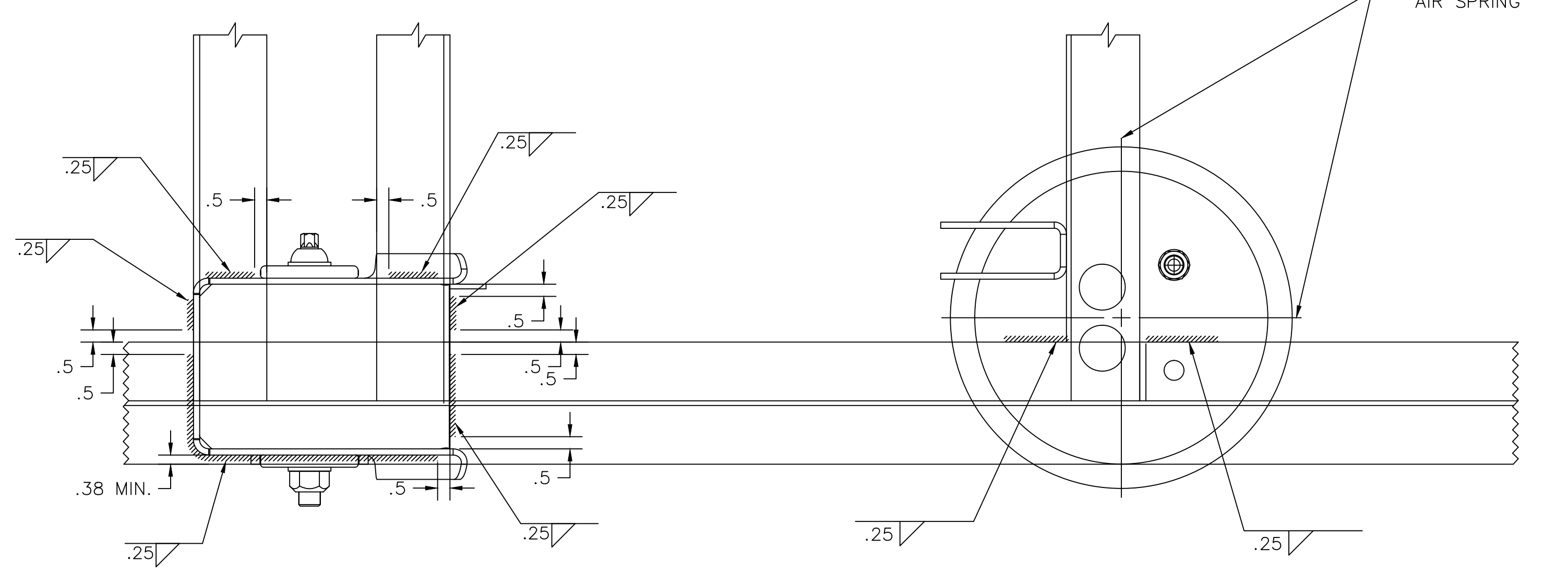
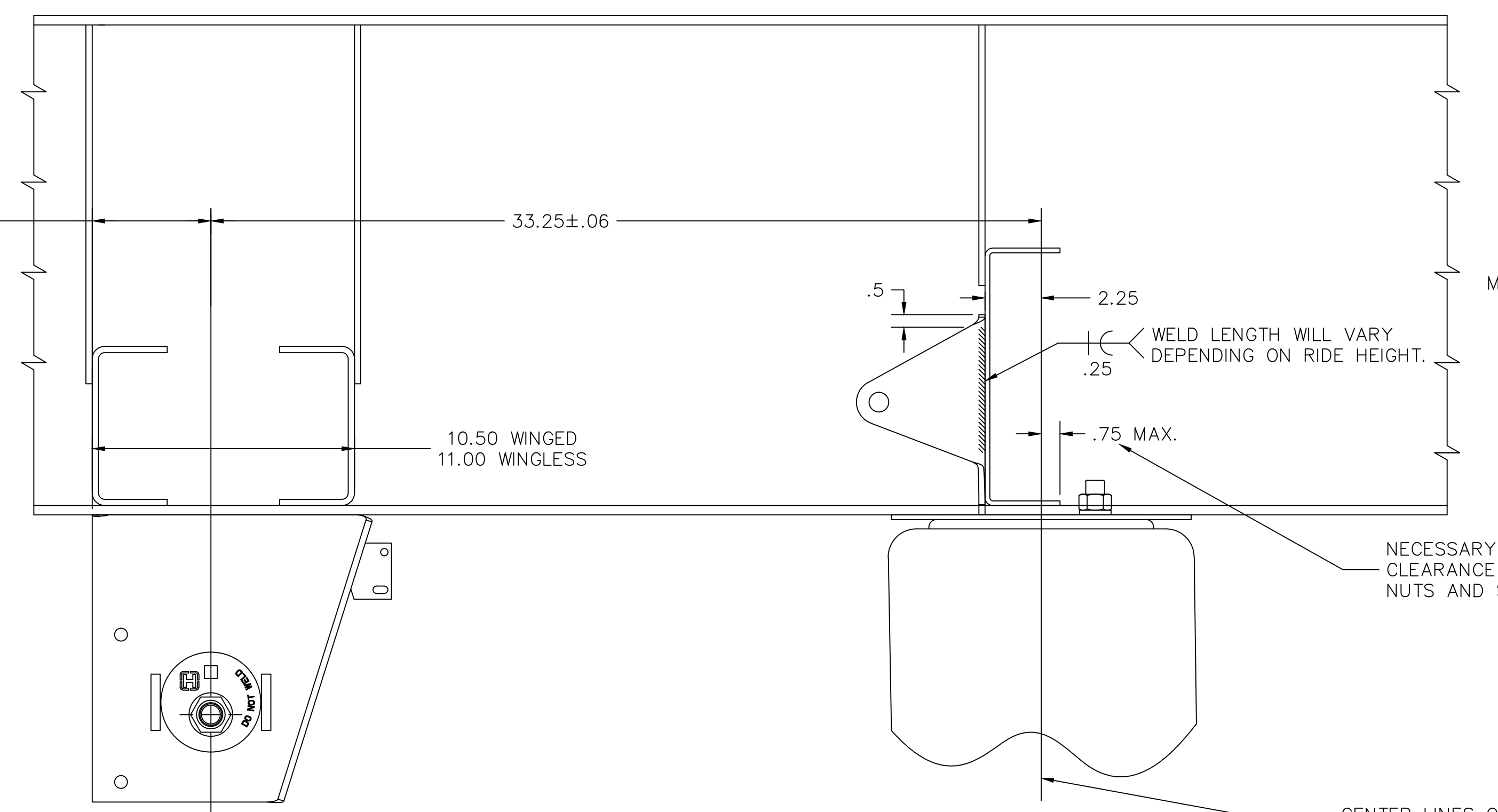
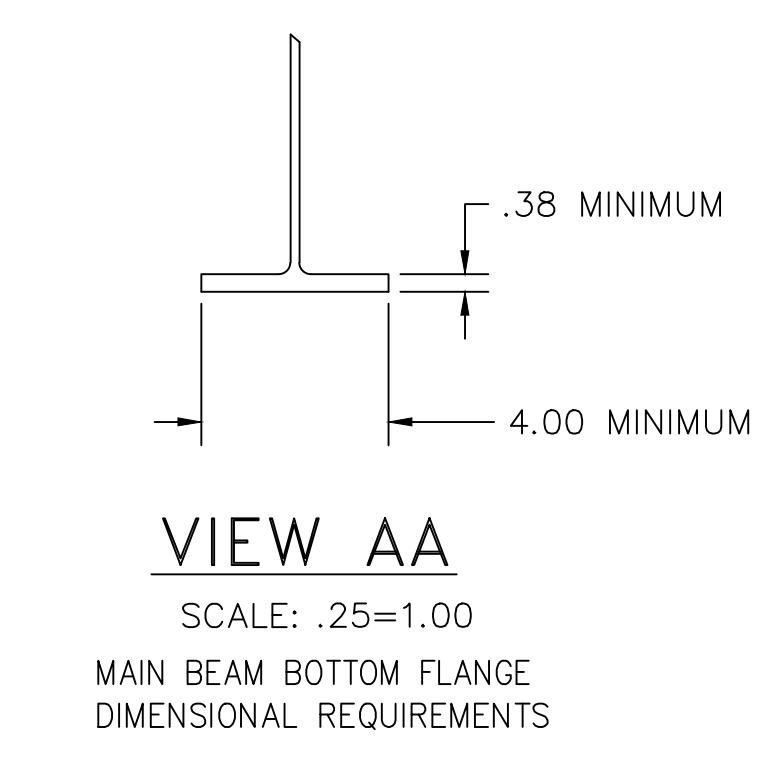
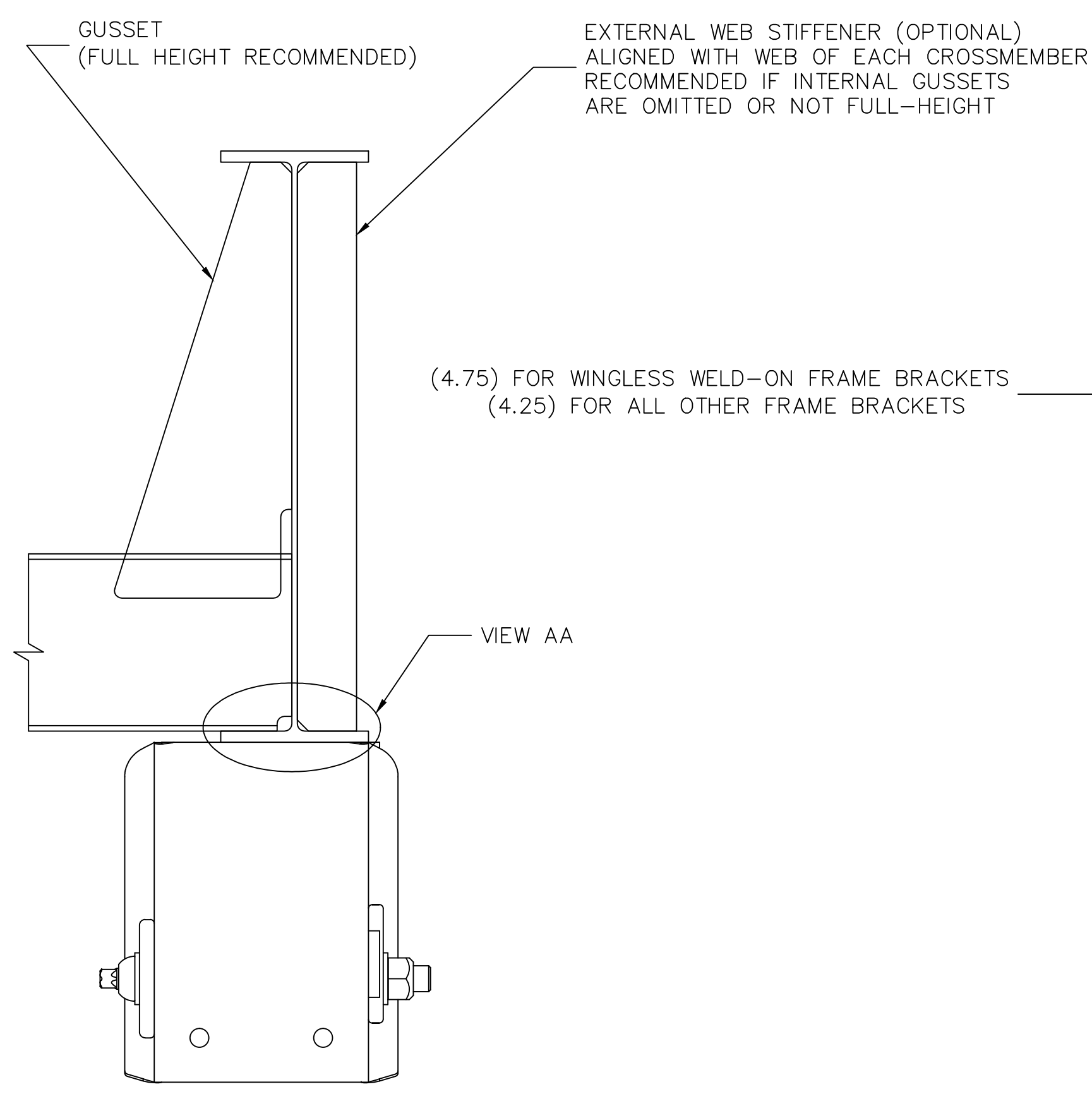

- NOTES:**
1. PATTERN DENOTES WELD PLACEMENT
  2. CROSSMEMBER AND/OR GUSSETS MUST ADEQUATELY SUPPORT UPPER AIR SPRING PLATE AND SHOCK MOUNT. A/S BUMPER 20,000 LB. AT FULL JOUNCE. SHOCK MOUNT 8,000 LB. EACH AT FULL REBOUND. THROUGH AIR SPRING BUMPER.
  3. SEE L577 INSTALLATION INSTRUCTIONS FOR ADDITIONAL INFORMATION ON FRAME BRACKET, CROSS MEMBER, UPPER SHOCK BRACKET AND AIR SPRING MOUNTING WELDING PROCEDURES.

This Print remains the property of Hendrickson. All information contained thereon is confidential. It is loaned, subject to return on demand and on express condition that it is not to be copied or used directly or indirectly for any purpose other than the purpose for which it has been loaned to you.

P  
PRODUCTION

# FRAME BRACKET STANDARD BOLT PATTERN

FRAME BRACKET  $\phi$

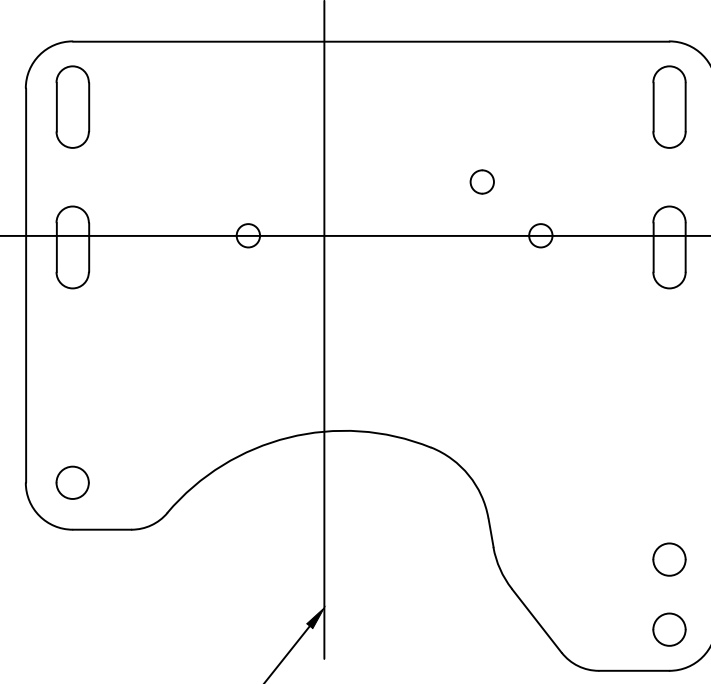

$\phi$  OF PIVOT

$B \pm .06$   
FRAME BRACKET  
/ SUPS. BEAM  $\phi$ - $\phi$

FRAME BRACKET  $\phi$

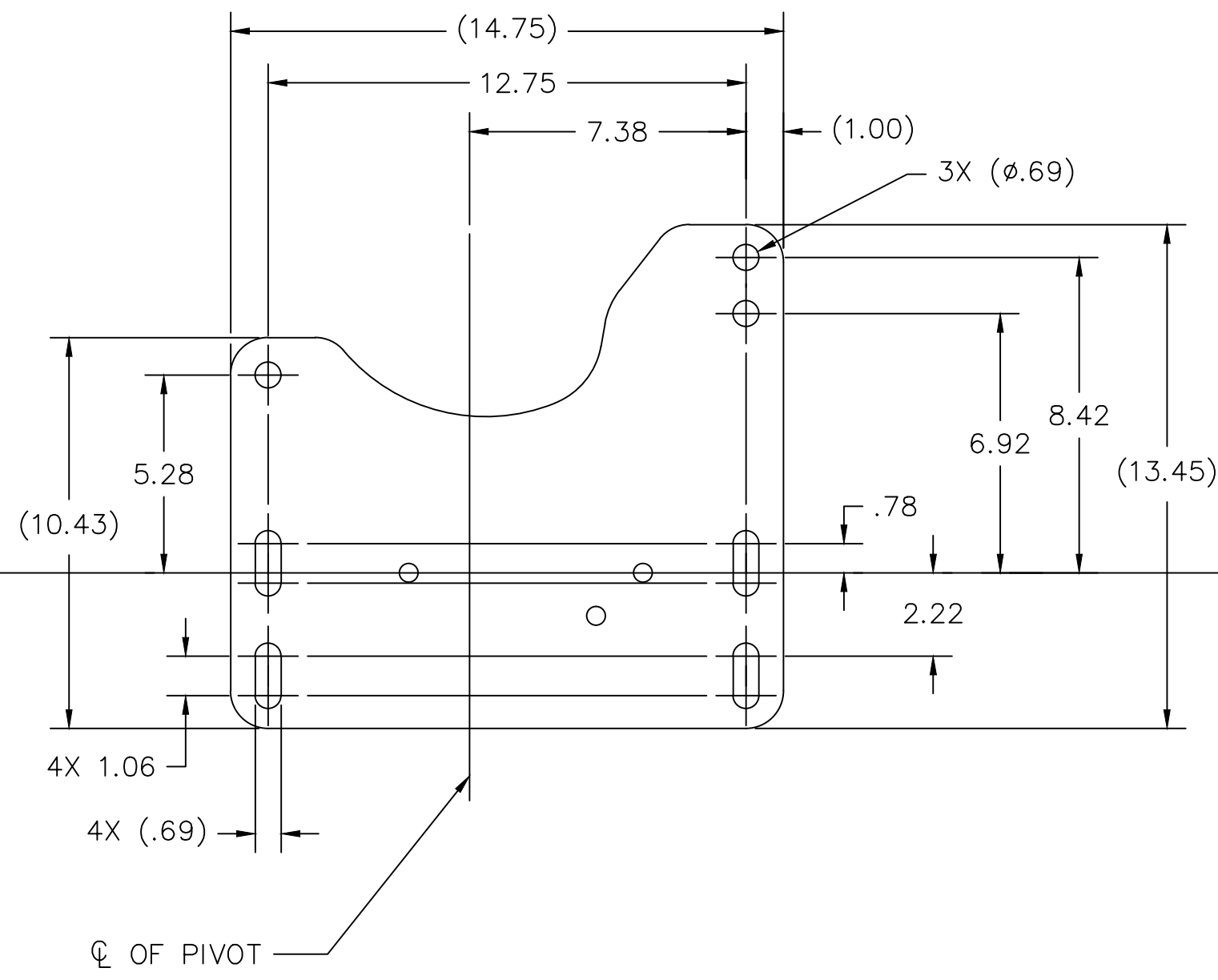

# FRAME BRACKET OFFSET BOLT PATTERN

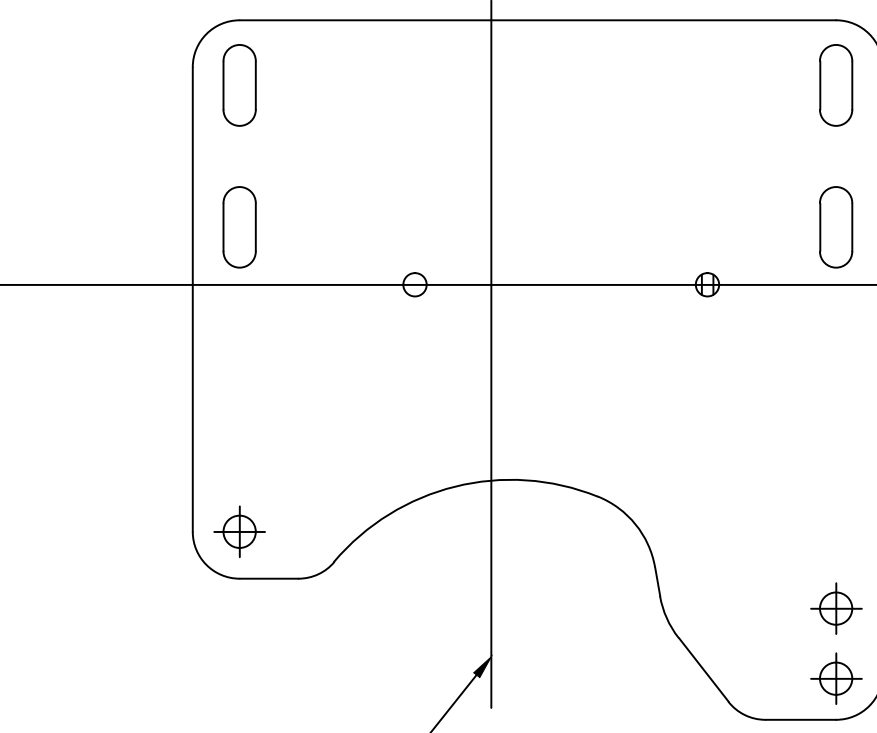

$\phi$  OF PIVOT

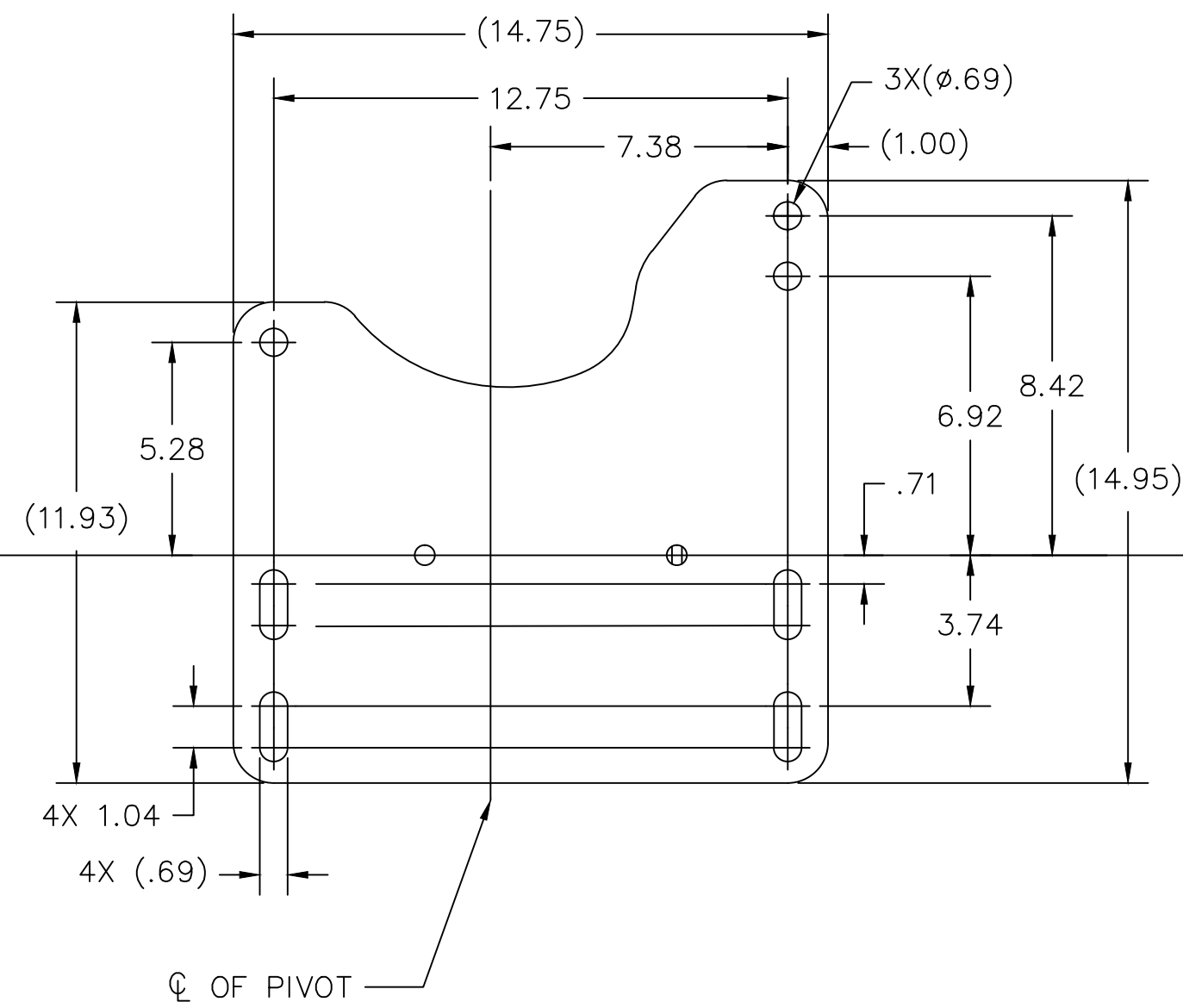

# AIR SPRING MOUNT STANDARD BOLT PATTERN

ANY ONE OF THESE THREE REQUIRED

ANY ONE OF THESE THREE REQUIRED

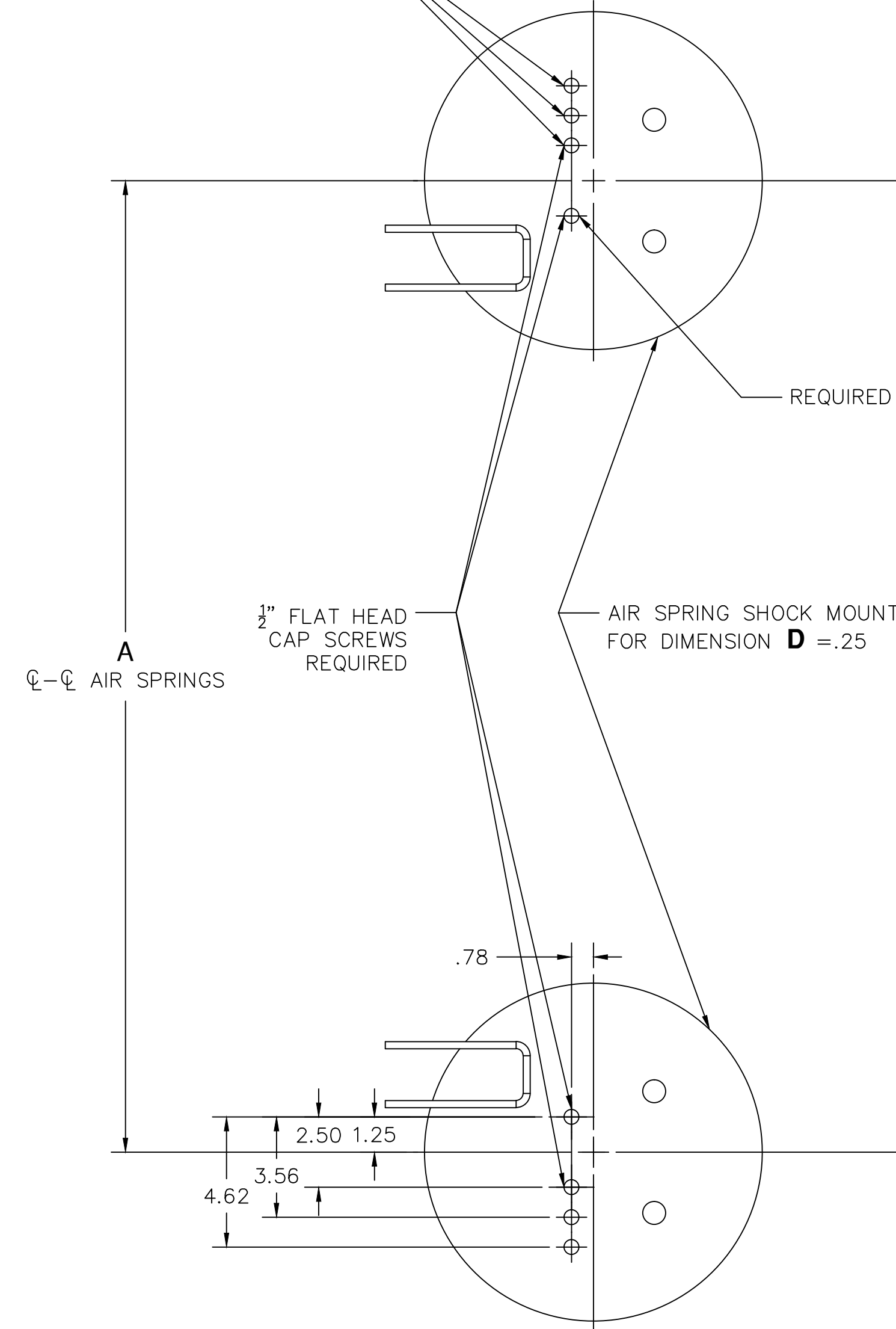

$A$   
 $\phi$ - $\phi$  AIR SPRINGS

1/2" FLAT HEAD  
CAP SCREWS  
REQUIRED

AIR SPRING SHOCK MOUNT  
FOR DIMENSION  $D = .25$

1/2" BOLTS  
REQUIRED

AIR SPRING SHOCK MOUNT  
FOR DIMENSION  $D > .25$

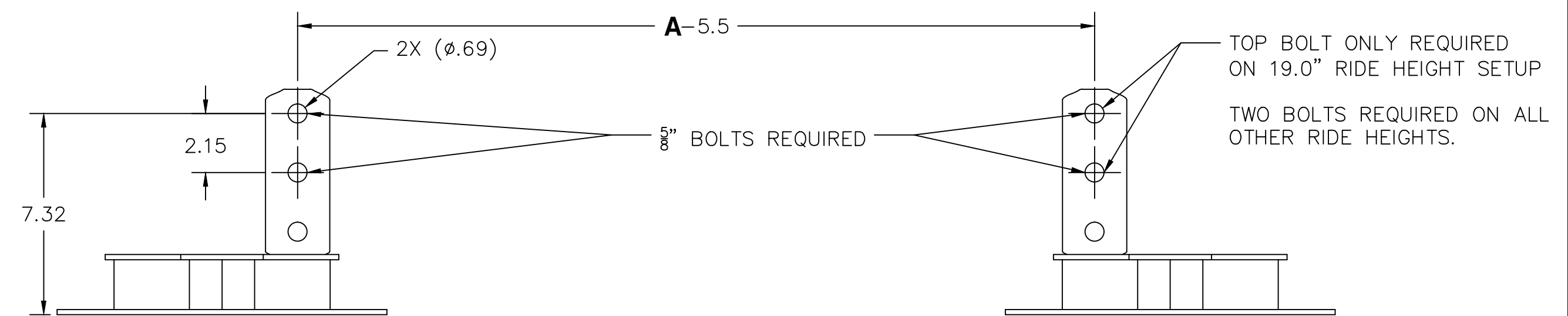

TOP BOLT ONLY REQUIRED  
ON 19.0" RIDE HEIGHT SETUP  
TWO BOLTS REQUIRED ON ALL  
OTHER RIDE HEIGHTS.

## IMPORTANT

### NOTES:

1. FRAME BRACKET SLOT MOUNTING BOLTS REQUIRES 5/8" FASTENERS WITH HARDENED WASHERS.
2. FRAME BRACKET MOUNTING BOLTS CAN BE PLACED IN ANY POSITION IN THE FOUR SLOTS.
3. SEE PAGE 3 FOR TABULATED DIMENSIONS.

This Print remains the property of Hendrickson. All information contained thereon is confidential. It is loaned, subject to return on demand and on express condition that it is not to be copied or used directly or indirectly for any purpose other than the purpose for which it has been loaned to you.

**HENDRICKSON**

TRAILER COMMERCIAL VEHICLE SYSTEMS  
2070 INDUSTRIAL PLACE S.E., CANTON, OH 44707-2600 U.S.A.

UNLESS OTHERWISE NOTED:		7	043125	SLB	02-05-24	DRWN BY	J. HOFER	7-9-15
TOLERANCES ARE:		6	34501	SLB	01/05/21	CHK'D BY	C. RADCLIFF	
DIMENSIONS ARE:		5	33407	KLE	01/20/20	APP'D BY:	K. ERDMANN	
INCHES		4	31111	SLB	05-15-18	BY	DATE	
ANGULAR: ±								
3RD ANGLE PROJECTION								
DIMENSIONS ADHERE TO ANSI Y14.5M-1982								

CONNEX® ST  
INSTALLATION DRAWING

SCALE 1:4 SIZE D PAGE 6 OF 8

DRAWING No. D-36237

P  
PRODUCTION

**C-CHANNEL WELD DETAIL**  
**FRAME ATTACHMENT: WINGLESS WELD-ON**

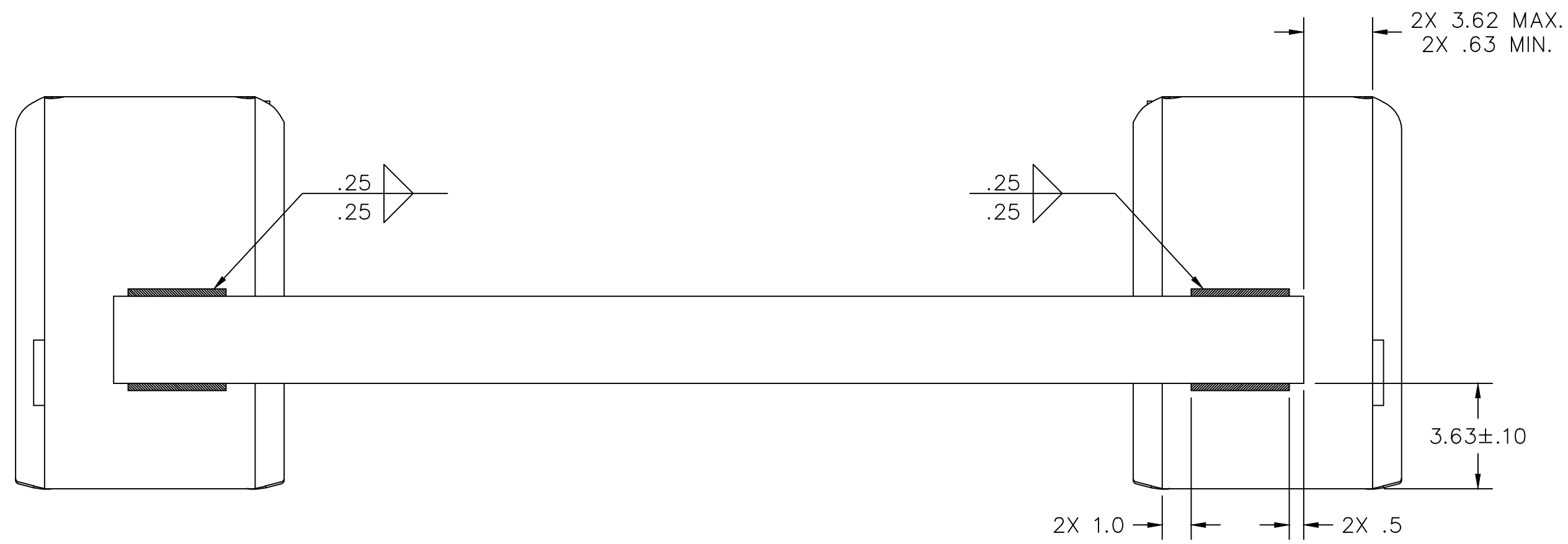

**FRAME BRACKET GUSSET WELD DETAIL**  
**FRAME ATTACHMENT: WINGED WELD-ON**

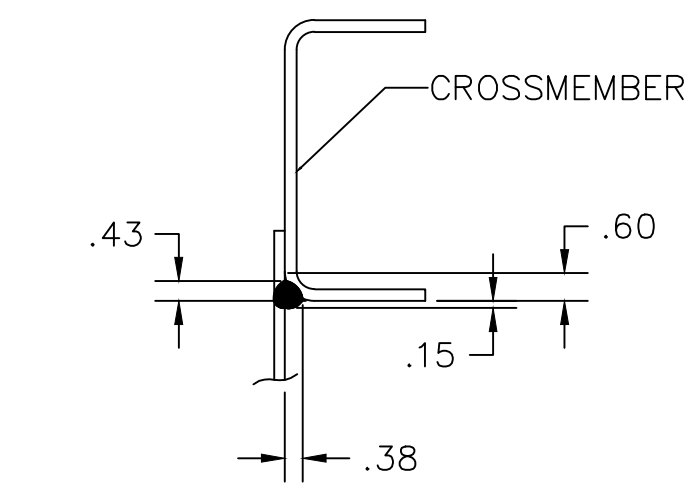
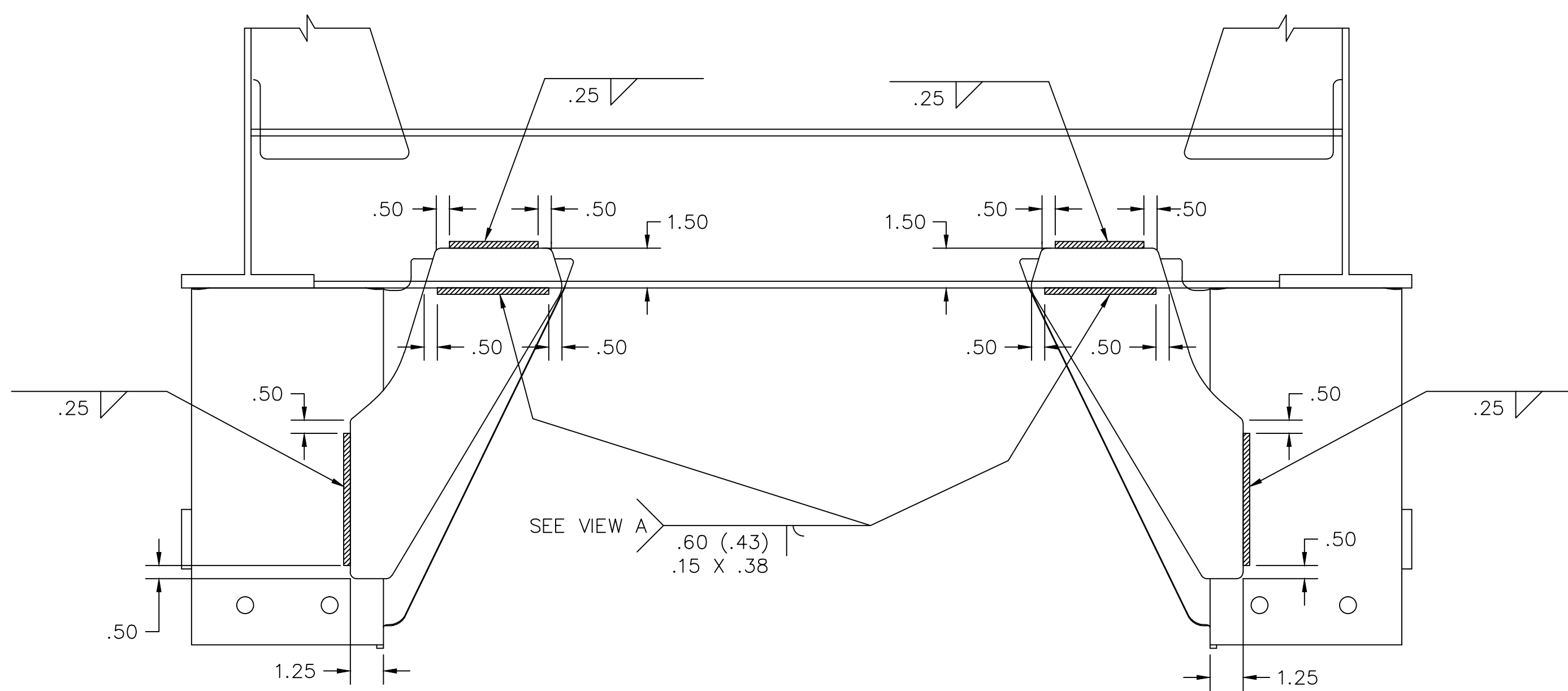

**VIEW A**  
 SCALE: .25=1.00

**NOTES:**

1. PATTERN DENOTES WELD PLACEMENT
2. SEE L577 HT INSTALLATION INSTRUCTIONS FOR ADDITIONAL INFORMATION ON FRAME BRACKET AND CROSSMEMBER WELDING PROCEDURES.
3. SEE PAGE 3 FOR TABULATED DIMENSIONS.

**BOLT-ON C-CHANNEL WITH STRUTS**  
**INSTALLATION DETAILS**  
**FRAME ATTACHMENT: BOLT-ON**

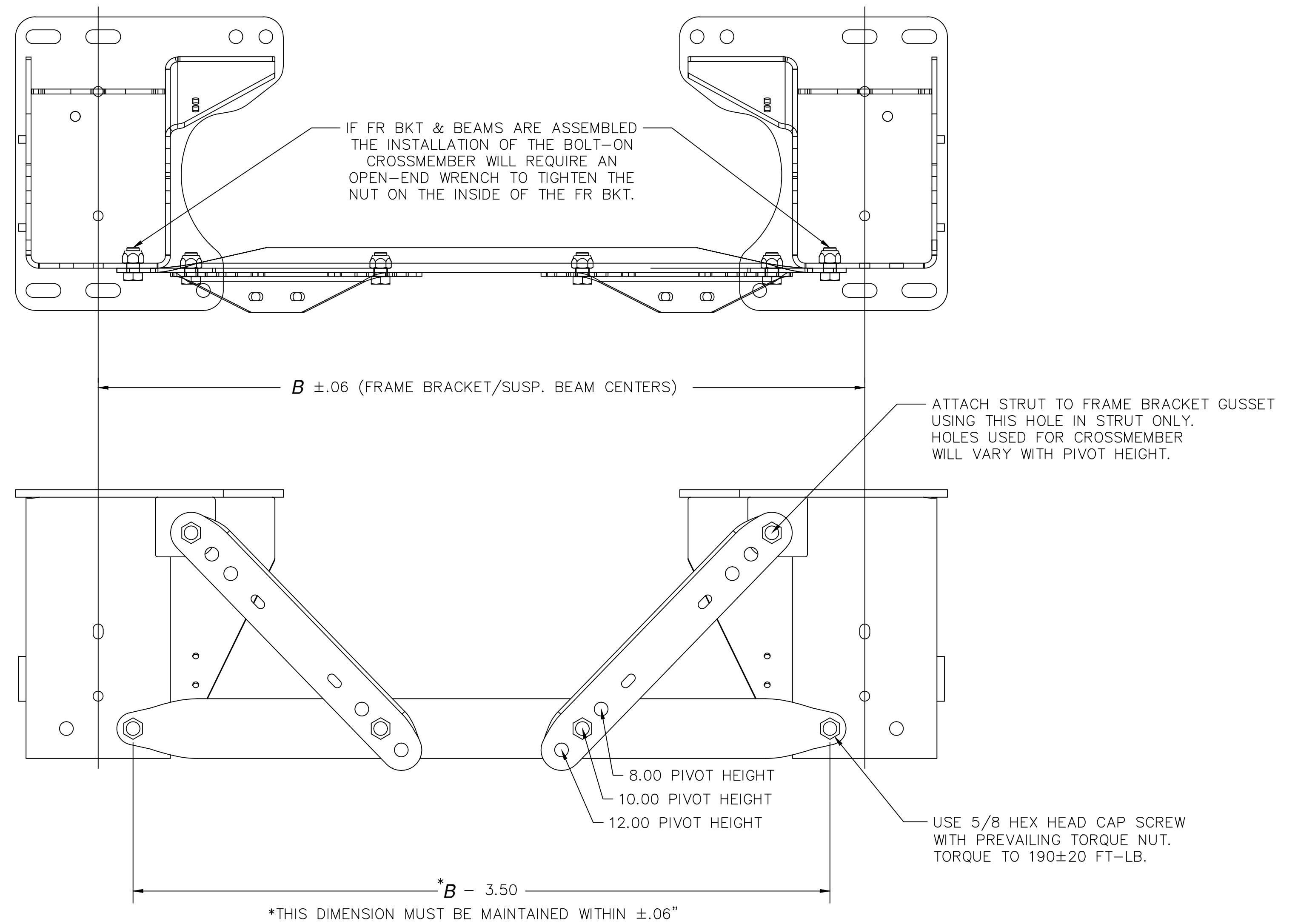

**INSTALLATION SEQUENCE:**

1. LOCATE FRAME BRACKETS ONTO TRAILER FRAME, AND LOOSELY INSTALL MOUNTING BOLTS.
2. INSTALL CROSSMEMBER, USING 5/8" MOUNTING HOLES ON FRONT OF FRAME BRACKETS.
3. INSTALL STRUTS, USING 5/8" MOUNTING HOLES IN FRAME BRACKET GUSSET AND CROSSMEMBER.
4. TIGHTEN CROSSMEMBER MOUNTING BOLTS AND STRUT MOUNTING BOLTS, IF PRESENT.
5. TIGHTEN FRAME BRACKET MOUNTING BOLTS.

FRAME ATTACHMENT	WELD-ON		BOLT-ON
	WINGED	WINGLESS	WINGED
FRAME BRACKET STYLE			
RIDE HEIGHT			
13.0			
14.0			
15.0	FRAME BRACKET GUSSET REQUIRED	C-CHANNEL REQUIRED	C-CHANNEL REQUIRED
16.0			
17.0			
18.0			
19.0			

IT IS THE RESPONSIBILITY OF THE SUSPENSION INSTALLER TO PROVIDE AN EQUIVALENT FRAME BRACKET SUPPORT IF THE FRAME BRACKET BRACING IS NOT PURCHASED FROM HENDRICKSON.

This Print remains the property of Hendrickson. All information contained thereon is confidential. It is loaned, subject to return on demand and on express condition that it is not to be copied or used directly or indirectly for any purpose other than the purpose for which it has been loaned to you.



TRAILER COMMERCIAL VEHICLE SYSTEMS  
 2070 INDUSTRIAL PLACE S.E., CANTON, OH 44707-2600 U.S.A.

UNLESS OTHERWISE NOTED: TOLERANCES ARE:	7 043125 SLB 02-05-24	DRWN BY J. HOFER	7-9-15
DIMENSIONS ARE:	6 34501 SLB 01/05/21	CHK'D BY C. RADCLIFF	
.X: ±	5 33407 KLE 01/20/20	APP'D BY K. ERDMANN	
.XX: ±	4 31111 SLB 05-15-18		
.XXX: ±			
ANGULAR: ±			
DIMENSIONS ADHERE TO ANSI Y14.5M-1982	REV. ECN NO. BY DATE		

CONNEX® ST  
 INSTALLATION DRAWING

SCALE 1:4 SIZE D PAGE 7 OF 8

D-36237

P  
 PRODUCTION

This Print remains the property of Hendrickson. All information contained thereon is confidential. It is loaned, subject to return on demand and on express condition that it is not to be copied or used directly or indirectly for any purpose other than the purpose for which it has been loaned to you.

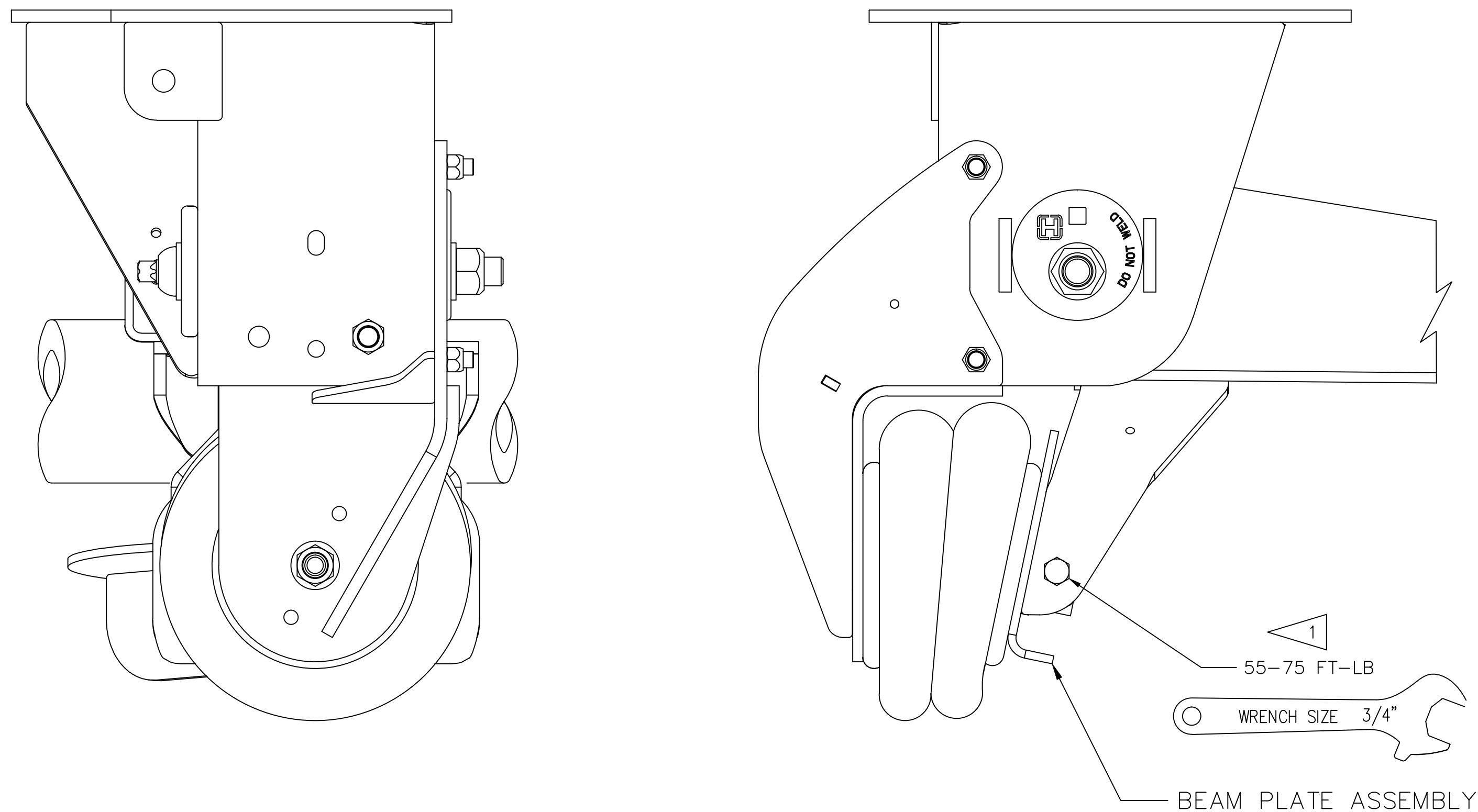

## BEAM BRACKET ASSEMBLY PROCEDURE

**1** ASSEMBLING AIR SPRING MOUNTING PLATE  
INSTALL BEAM PLATE ASSEMBLY USING (4) 1/2-13 X 1.25 HEX CAP SCREW AND (4) 1/2-13 NUTS AND TIGHTEN TO SPECIFIED TORQUE.

## FRONT BRACKET ASSEMBLY PROCEDURE

SCALE: 1:6

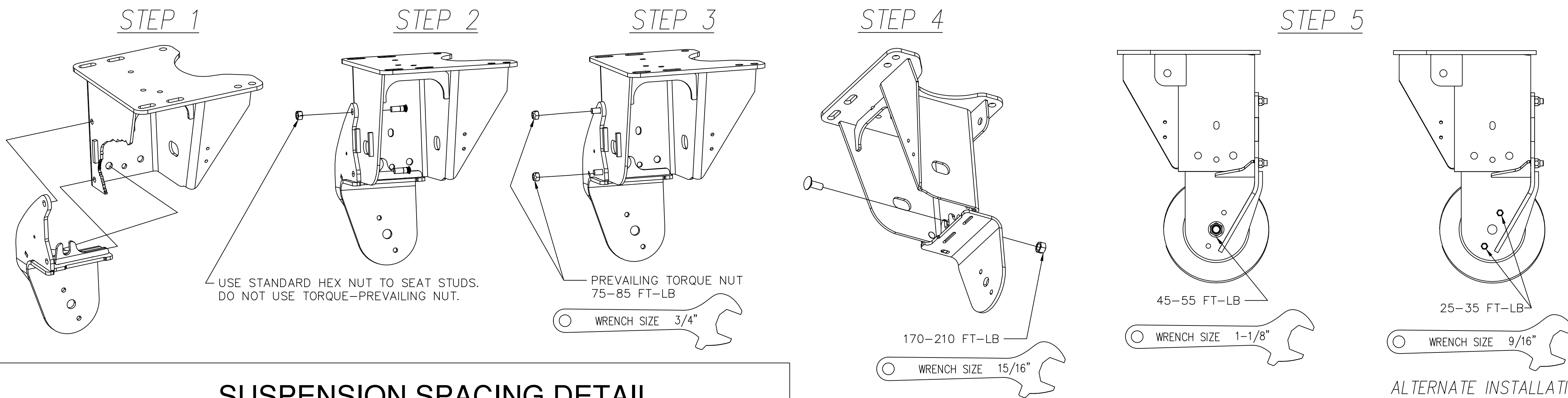

\*\* FRONT BRACKET MUST BE IN PLACE BEFORE SEATING THE RIBBED-NECK BOLTS. BRACKET CANNOT BE INSTALLED IF BOLTS ARE INSTALLED PRIOR TO POSITIONING OF THE BRACKET.

- FITTING BRACKET INTO PLACE.**  
SLIDE FRONT BRACKET INTO PLACE, MAKING SURE THAT ALL MOUNTING HOLES IN UBL BRACKET ALIGN WITH HOLES IN FRAME BRACKET.
- INSERTING SIDE MOUNTING BOLTS.**  
HOLDING THE FRONT BRACKET IN PLACE, PUSH RIBBED-NECK FASTENERS INTO MOUNTING HOLES FROM INSIDE OF FRAME BRACKET. INSERT AND TIGHTEN THE PROVIDED 1/2-13 STANDARD (NON-LOCKING) HEX NUT ON EACH RIBBED-NECK FASTENER. AS THE NUT IS TIGHTENED, THE FASTENER WILL BE DRAWN INTO THE FRAME BRACKET MOUNTING HOLES. TIGHTEN THE NUT UNTIL THE HEAD OF THE FASTENER IS FLUSH WITH THE INSIDE OF THE HANGER.  
(HEX NUT CAN BE REUSED TO SEAT ALL FOUR RIBBED-NECK FASTENERS. DO NOT USE PREVAILING TORQUE NUTS TO SEAT RIBBED-NECK BOLTS)
- TIGHTENING SIDE MOUNTING BOLTS.**  
PLACE 1/2-13 PREVAILING TORQUE NUTS ONTO RIBBED-NECK FASTENERS AND TORQUE TO SPECIFIED VALUE.
- INSTALLING FRONT MOUNTING BOLT.**  
PLACE 5/8-11 X 1.50 CARRIAGE BOLT THROUGH FRONT MOUNTING HOLE WITH THE BOLT HEAD WITH THE INSIDE OF THE FRAME BRACKET (NEAREST THE PIVOT BUSHING). HOLD CARRIAGE BOLT IN HOLE AND PLACE 5/8-11 TORQUE PREVAILING HEX NUT ONTO BOLT AND TORQUE TO SPECIFIED VALUE.
- AIR SPRING ASSEMBLY.**  
ASSEMBLE THE AIR SPRING WITH THE AIR INLET FACING TO THE FRONT OR REAR, DEPENDING ON AIR LINE ORIENTATION PREFERENCE. TIGHTEN THE 3/4-16 FLANGE NUT AND 3/8-16 X .88 BOLTS TO SPECIFIED TORQUES.

## SUSPENSION SPACING DETAIL

SCALE: 1:6

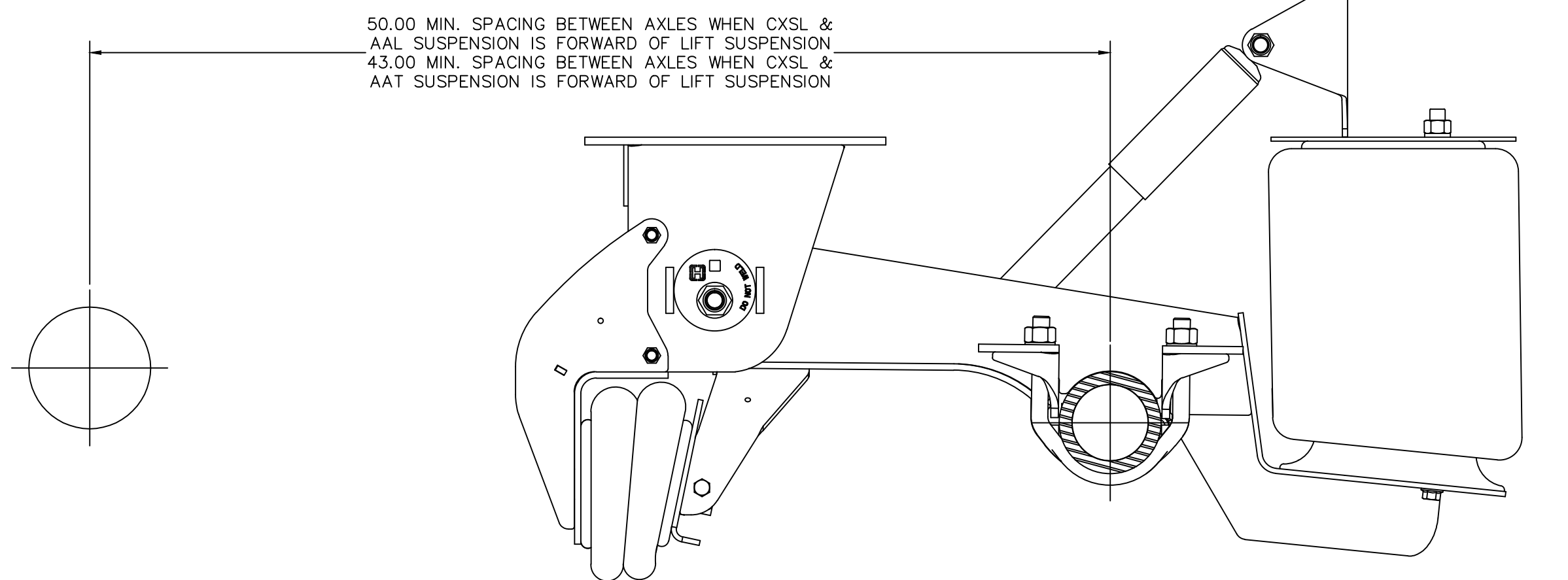

- NOTES:
- 14" RIDE HEIGHT SHOWN, INSTALLATION IS THE SAME FOR ALL RIDE HEIGHTS
  - SEE L1182 CONTROLS PARTS CATALOG FOR LIFT AXLE CONTROL KITS

ALTERNATE INSTALLATION:  
AIR INLET TOWARD REAR OF SUSPENSION