

H PARTS LIST

VANTRAX® HKAT 69K25

LIT NO: L1079

DATE: January 2022

REVISION: E

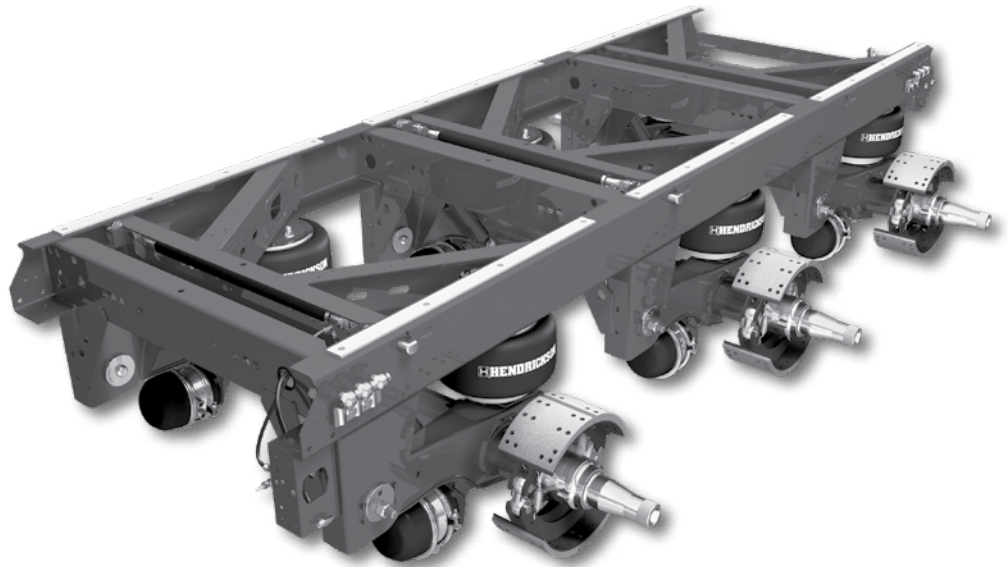
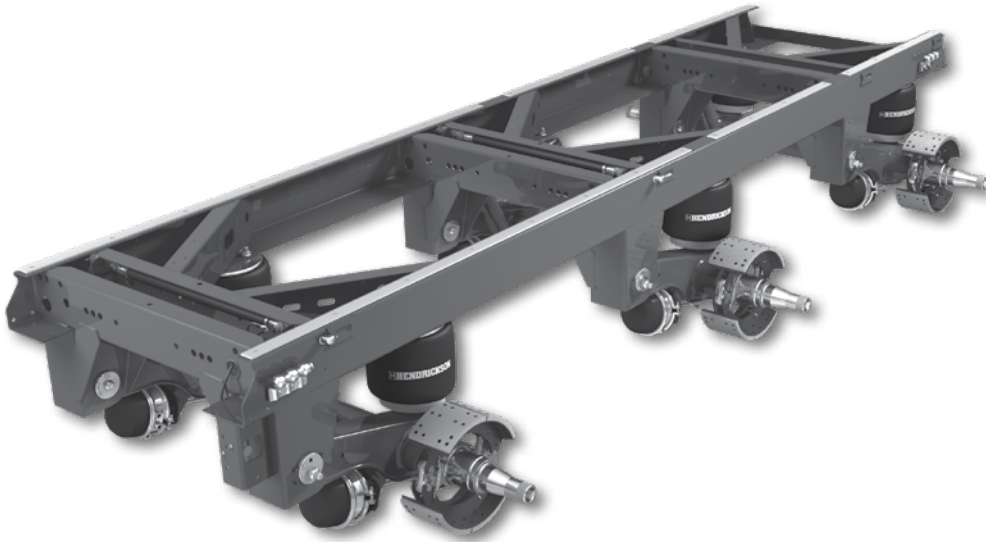



SLIDER BOX ASSEMBLY

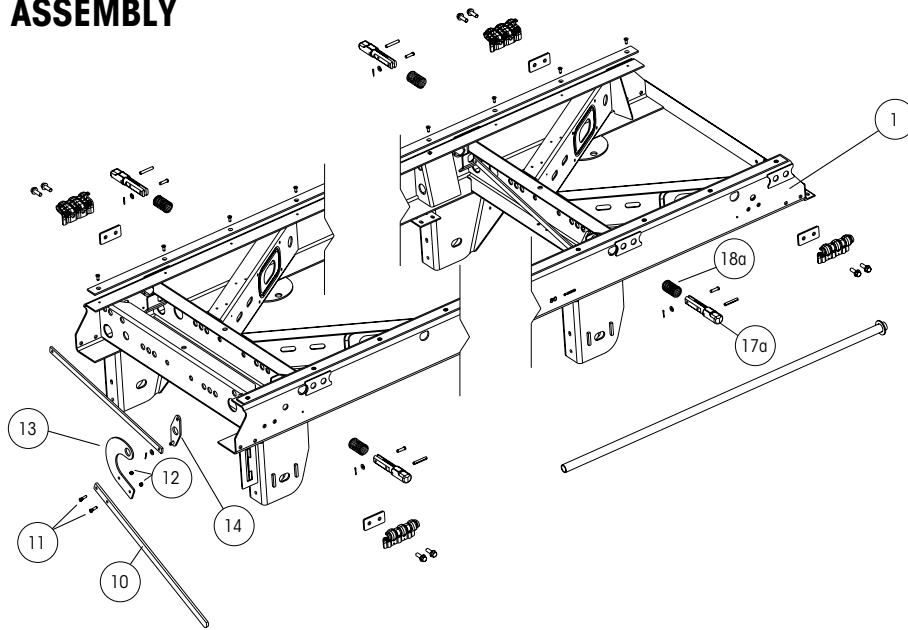

SLIDER PINS

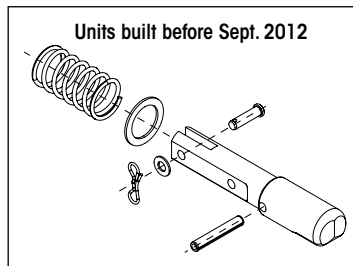
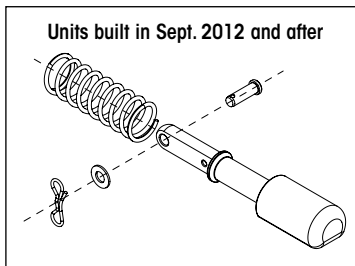

QUIK-DRAW® ACTUATOR ENDS

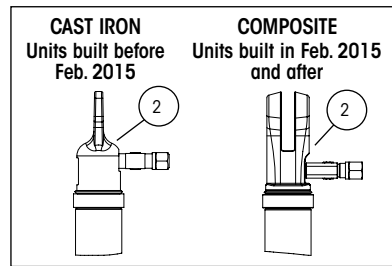

CURRENT PRODUCTION PIN-PULL RELEASE MECHANISMS

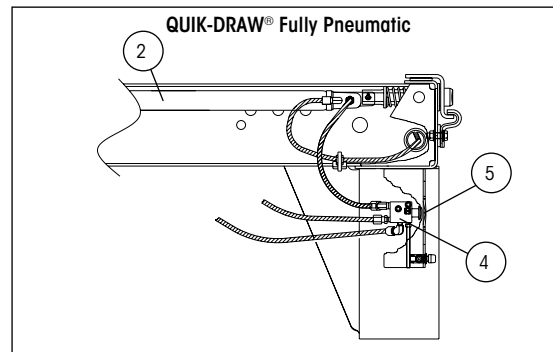
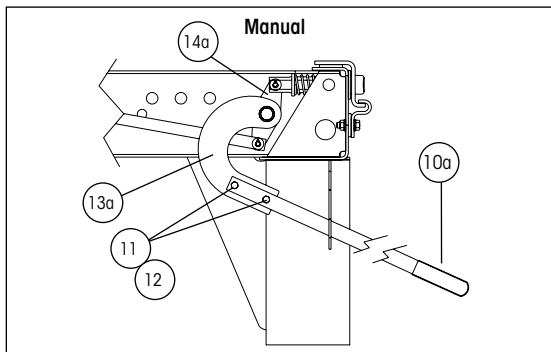

NO LONGER AVAILABLE ON PRODUCTION MODELS OR BOX REPLACEMENTS — PARTS FOR THESE MECHANISMS ARE STILL AVAILABLE

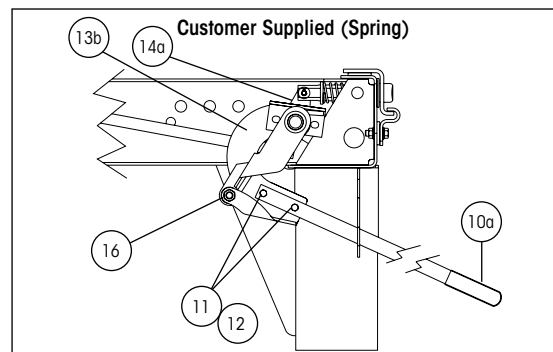
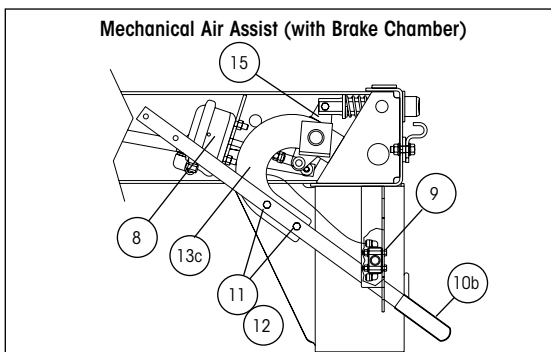

**SLIDER BOX ASSEMBLY**

ITEM	DESCRIPTION	PART NO.	SYSTEM QTY.	NOTE
1	AFTERMARKET BOX REPLACEMENT	AMBOX.###	1	Contact Hendrickson for assistance
2	QUIK-DRAW® PNEUMATIC PIN-PULL MECHANISM			See L751 QUIK-DRAW Parts List
3	PIN EXTENSION 54" BOX WIDTH			See L751 QUIK-DRAW Parts List
4	QUIK-DRAW VALVE			See L751 QUIK-DRAW Parts List
5	QUIK-DRAW VALVE KNOB with SCREW SET			See L751 QUIK-DRAW Parts List
6	QUIK-DRAW VALVE SPACER (not shown)			See L751 QUIK-DRAW Parts List
7	QUIK-DRAW RETROFIT KIT (not shown)			See L751 QUIK-DRAW Parts List
8	BRAKE CHAMBER MECHANICAL AIR ASSIST	A-23039	1	Type 12 modified
9	AIR VALVE MECHANICAL AIR ASSIST	VS-23224	1	Includes air valve with fittings
10	HANDLE ASSEMBLY			
	10a Manual / Customer supplied	S-25592	1	Handle and grip assembly
	10b Mechanical air assist	B-22923	1	Handle only
11	HANDLE BOLT	SA-1100-10	2	2-3/8"-16 x 1-1/4" hex head bolt, grade 5
12	HANDLE NUT	SA-9000-5	2	2-3/8"-16 lock nut, grade B
13	HANDLE MOUNT			
	13a Manual	C-21275	1	
	13b Customer supplied	S-23534	1	
	13c Mechanical air assist	C-23231	1	Includes crank arm bolt kit
14	CRANK WELDMENT			
	14a Manual and customer supplied	B-33010	2	For front and rear of slider box
	14b Mechanical air assist - rear (not shown)	B-33010	1	For rear of slider box
15	CRANK PLATE	B-23025	1	Mechanical Air Assist
16	CRANK ARM BOLT KIT	A-22041	1	Includes bolt, flat washer, lock washer & nut

Note: Narrow hanger shown. Pin pull mechanisms are identical for both wide and narrow width slider models.

Note: Identification can be found on the roadside slider box rail above the front frame bracket. There is also a blank INTRAAX tag on the inside of the curbside beam.



SLIDER BOX ASSEMBLY

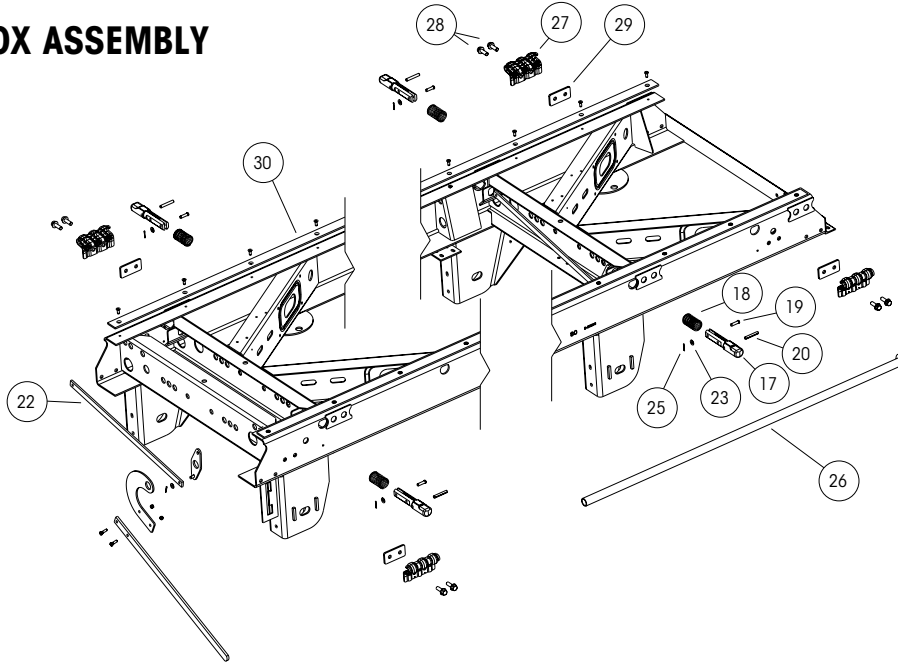

SLIDER PINS

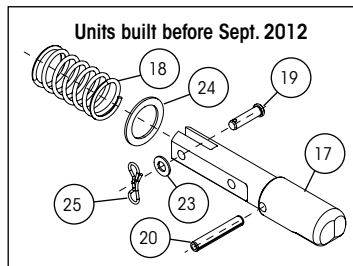
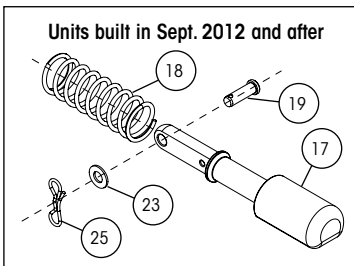

QUIK-DRAW[®] ACTUATOR ENDS

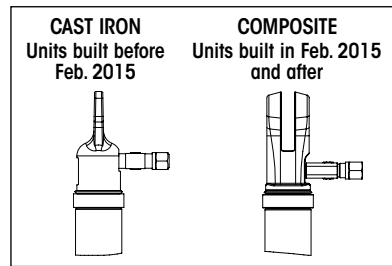

CURRENT PRODUCTION PIN-PULL RELEASE MECHANISMS

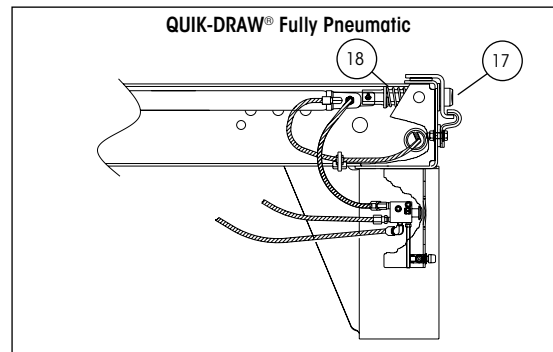
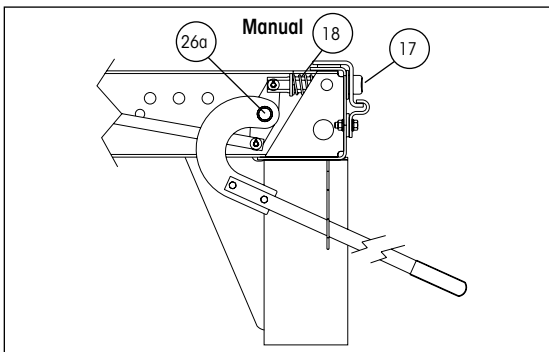

NO LONGER AVAILABLE ON PRODUCTION MODELS OR BOX REPLACEMENTS — PARTS FOR THESE MECHANISMS ARE STILL AVAILABLE

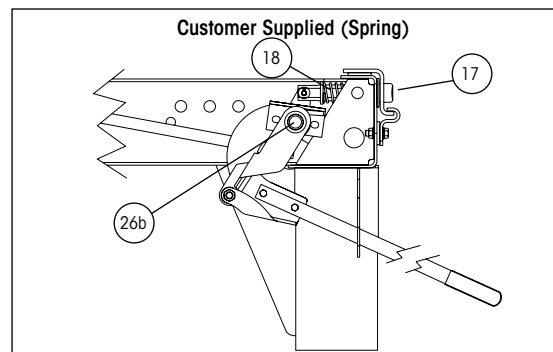
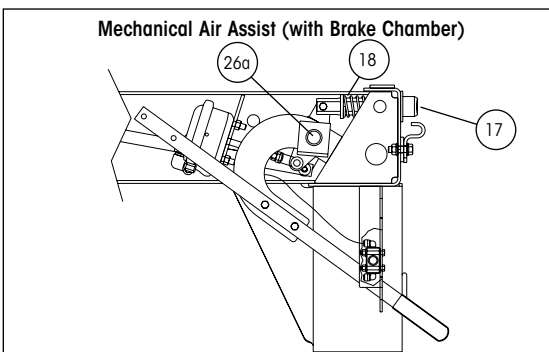

**SLIDER BOX ASSEMBLY**

ITEM	DESCRIPTION	PART NO.	SYSTEM QTY.	NOTE
17	LOCKING PIN			See L751 QUIK-DRAW® Parts List
18	LOCKING PIN SPRING			See L751 QUIK-DRAW Parts List
19	CLEVIS PIN			See L751 QUIK-DRAW Parts List
20	SPRING PIN (Units built before Sept. 2012)			See L751 QUIK-DRAW Parts List
21	PIN GUIDE (not shown)			
	Roadside	S-29646-1	2	
	Curbside	S-29646-2	2	
22	LOCKING PIN LINK			See L751 QUIK-DRAW Parts List
23	LOCKING PIN WASHER			See L751 QUIK-DRAW Parts List
24	PIN WASHER (Units built before Sept. 2012)			See L751 QUIK-DRAW Parts List
25	LOCKING COTTER PIN			See L751 QUIK-DRAW Parts List
26	PIPE WELDMENT			
	26a Manual and mechanical air assist	S-21433	1	
	26b Customer supplied	S-21433-1	1	
27	BODY RAIL CLIP			
	27a 3.4" clip height	S-24459	4	Use with 4" hole centers and 1.625" locking pin
	27b 3.8" clip height	S-24460	4	Use with 6" hole centers and 1.375" locking pin
28	BODY RAIL BOLT	SA-6900-2	8	1/2"-13" x 1-1/2" flanged bolt
29	BODY RAIL CLIP SPACER	A-22367	6	2" clip hole centers
30	SLIDER WEAR PAD KIT	S-14342-3	2	Includes (1) slider wear pad and (8) screws

Note: Identification can be found on the roadside slider box rail above the front frame bracket. There is also a blank INTRAAX tag on the inside of the curbside beam.



SUSPENSION ASSEMBLIES

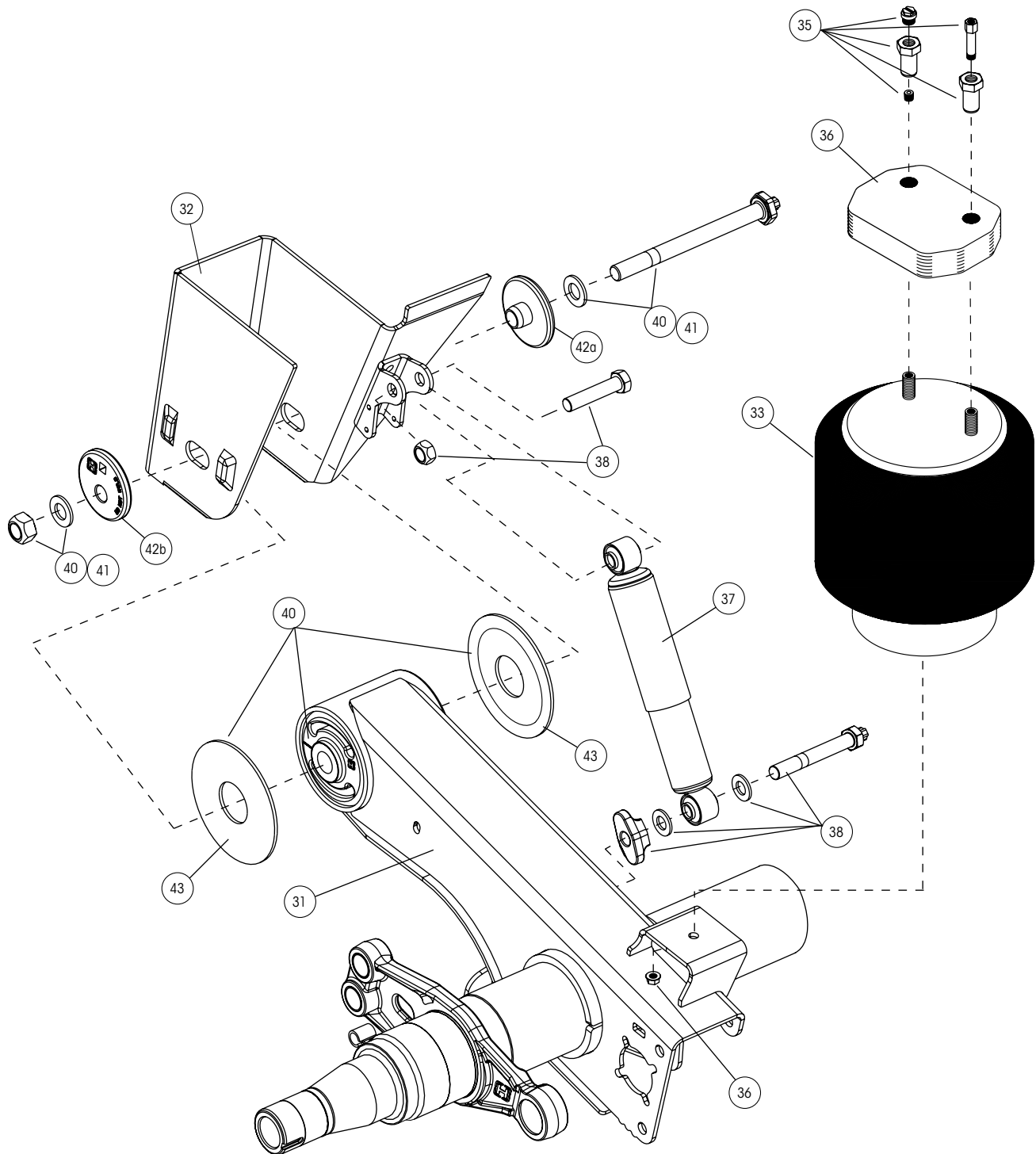

Drawing is a general representation of the actual suspension. Not all components are shown.

**SUSPENSION ASSEMBLIES**

ITEM	DESCRIPTION	PART NO.	SYSTEM QTY.	NOTE
31	HALF-TRAAX AXLE/BEAM WELDMENT	HTRAAX,###	3	Contact Hendrickson for assistance
32	FRAME BRACKET			See L1266 Frame Bracket Parts List
33	AIR SPRING	S-23748	6	
34	AIR SPRING BOTTOM DISK (not shown)	S-21786	6	
35	AIR SPRING MOUNTING KIT (per air spring)			
	16" and 17" ride heights	S-22619/2	6	
	16.5" and 18" ride heights	S-22630/2	6	
	19" ride height	S-22632/2	6	
36	AIR SPRING SPACER			
	16.5" ride height	B-22510-4	6	3/4" thick spacer
	18" ride height	B-22510-4	6	3/4" thick spacer
37	SHOCK ABSORBER	S-24023	6	
38	SHOCK BOLT KIT (per shock)	S-24021	6	Includes shear bolt, spacer, washers, hex bolt and hex nut
39	SHOCK STRAPS (not shown)	C-23086-2	6	Includes straps, clevis and nylon ties. Use with S-24023 shock.
40	TRI-FUNCTIONAL® PIVOT BUSHING KIT ²	S-24691	6	Includes (1) bushing, (1) pivot bolt kit, (2) bushing tube spacers and lubricant pack
41	QUIK-ALIGN® PIVOT BOLT KIT	S-24679	6	Contains 10" bolt, nut and hardened washers
42	QUIK-ALIGN ALIGNMENT COLLARS			
	42a Concentric (Inner)	S-20924	6	Pivot hole is in center of collar
	42b Eccentric (Outer)	S-20925	6	Pivot hole is offset from the center of collar
43	BUSHING TUBE SPACER	S-21099	12	

OTHER PARTS LISTS

More information can be found in the following documents

Lit. Number	Description
L1055	SURELOK® Parts List
L1102	Slider Accessories and Axle Components Parts List
L949	RTR® READY-TO-ROLL® Parts List
L589	TRI-FUNCTIONAL® Bushing Replacement Tool
L1063	Air Disc Brakes Parts List
L1104	Brake Kits and Components Parts List

1. Other options may exist. Contact Hendrickson for assistance.

2. Bushing tool S-21307 is required to properly re-bush the suspension.

Note: Identification can be found on the roadside slider box rail above the front frame bracket. There is also a blank INTRAAX tag on the inside of the curbside beam.

*Actual product performance may vary depending upon vehicle configuration, operation, service and other factors.
All applications must comply with applicable Hendrickson specifications and must be approved by the respective vehicle manufacturer with the vehicle in its original, as-built configuration.
Contact Hendrickson for additional details regarding specifications, applications, capacities, and operation, service and maintenance instructions.*

Call Hendrickson at 330.489.0045 or 866.RIDEAIR (743.3247) for additional information.



www.hendrickson-intl.com

TRAILER COMMERCIAL VEHICLE SYSTEMS

2070 Industrial Place SE
Canton, OH 44707-2641 USA
866.RIDEAIR (743.3247)
330.489.0045 • Fax 800.696.4416

Hendrickson Canada ULC

2825 Argentia Road, Unit #2 - 4
Mississauga, ON Canada L5N 8G6
800.668.5360
905.789.1030 • Fax 905.802.9423

Hendrickson Mexicana

Circuito El Marqués Sur #29
Parque Industrial El Marqués
Pob. El Colorado, Municipio El Marqués,
Querétaro, México C.P. 76246
+52 (442) 296.3600 • Fax +52 (442) 296.3601

L1079 Rev E 01-22

© 2008 - 2022 Hendrickson USA, L.L.C. All Rights Reserved. All trademarks shown are owned by Hendrickson USA, L.L.C., or one of its affiliates, in one or more countries.
Information contained in this literature was accurate at the time of publication. Product changes may have been made after the copyright date that are not reflected.

Printed in United States of America