

**TARGET GAUGE**

- NOTE:** The following procedures assume:
- The trailer is not connected to a truck and the system integrity is good (no damage or leaks).
  - **Shop air supply must be** clean, dry and at least 15 psi above desired cold target (inflation) pressure.

**⚠WARNING:** Emergency air supply must be available at the Emergency supply port on the controller to enable TIREMAAX PRO operation. Supplying air at the emergency glad hand will also release trailer brakes.

For complete instructions, refer to Hendrickson literature number **T51009** TIREMAAX PRO *Installation, Service and Troubleshooting procedures*. This document should have been read before continuing with this version of the procedures.

1. **Chock** wheels or otherwise **immobilize trailer**.
2. **Locate** controller on the trailer. **Ensure** supply valve is in closed position.
3. **Open** controller cover. **Remove and save** test port vent.
4. **Connect** target gauge to the test port.
5. **Charge** trailer air tank by connecting the **shop air supply** to emergency brake and target gauge. Once charged, disconnect from emergency brake glad hand.

**\*IMPORTANT:** After an adjustment to lower pressure, press the target gauge pressure relief button to allow air to escape, then release before reading the gauge.

**TIREMAAX PRO CONTROLLER**

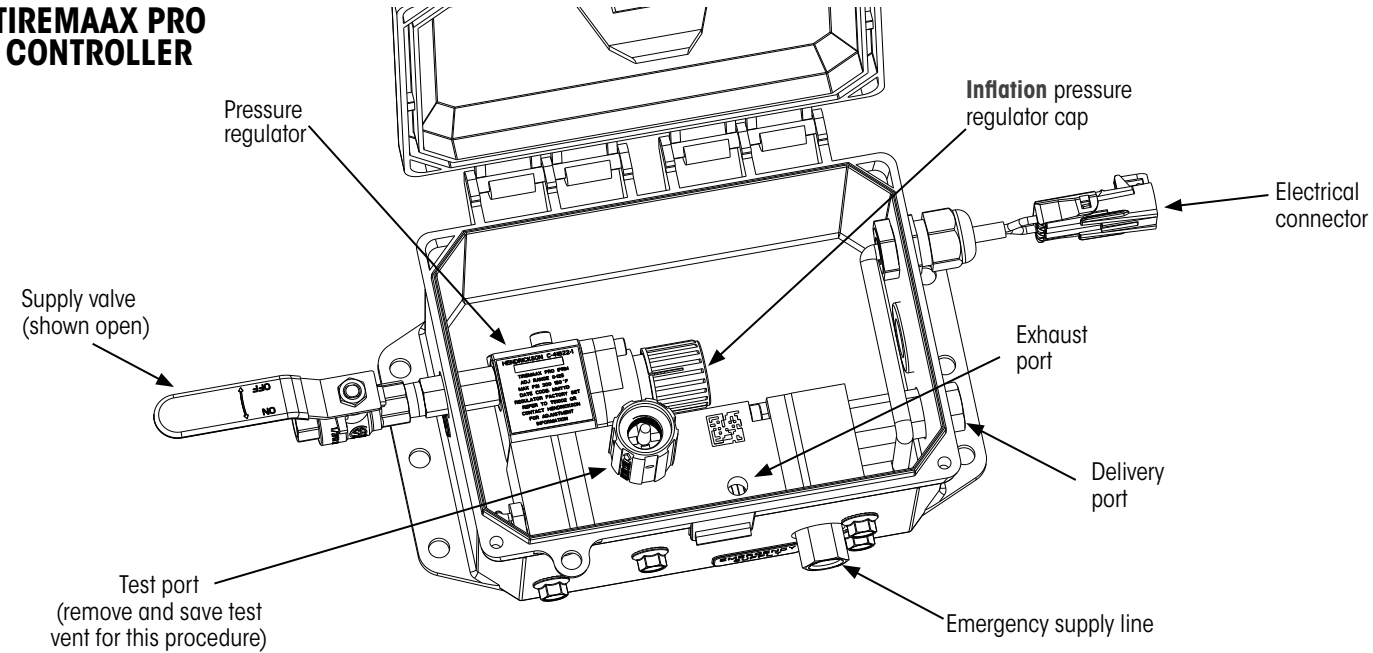

**INCREASE PRO COLD TARGET PRESSURE**

1. **Open** the controller supply valve.
2. **Remove** inflation regulator cap by pulling to right side.  
**NOTE:** Always approach the inflation pressure setting from an increasing pressure direction.\*
3. **Use** a 1/8 Allen wrench to **adjust** inflation regulator until desired inflation pressure is reached.\*
4. **Reinstall** regulator cap.

**DECREASE PRO COLD TARGET PRESSURE**

1. **Open** the controller supply valve.
2. **Remove** inflation regulator cap by pulling to right side.  
**NOTE:** Always approach the inflation pressure setting from an increasing pressure direction.\*
3. **Use** a 1/8 Allen wrench to **adjust** inflation regulator to a pressure below the target, then increase to target pressure.\*
4. **Reinstall** regulator cap.
5. **Close** the controller supply valve.

**RESTORE SYSTEM TO NORMAL OPERATION**

The controller should be set to the desired inflation and deflation pressure. To restore system to normal operation:

1. **Close** the target gauge supply valve.
2. **Disconnect** shop air supply from target gauge.
3. **Disconnect** target gauge from controller.
4. **Restore** the test vent in the "STORE" position.
5. **Close** controller lid, **secure** latch and **ensure** controller supply valve is open.
6. **Update** decal on controller cover, if necessary.

[www.hendrickson-intl.com](http://www.hendrickson-intl.com)  
**HENDRICKSON TRAILER COMMERCIAL VEHICLE SYSTEMS**  
 2070 Industrial Place SE  
 Canton, OH 44707-2641 USA