

# HENDRICKSON ASSEMBLY INSTRUCTIONS

## QUIK-ALIGN® Pivot Bushing Tool for PRIMAAX® EX • FIREMAAX® EX

**SUBJECT:** Tool No. 66086-203L

**LIT NO:** 59310-061

**DATE:** February 2023

**REVISION:** C

### INTRODUCTION

This publication is intended to assist maintenance personnel with the installation / removal of QUIK-ALIGN® pivot bushings with the help of Hendrickson Tool No. 66086-203L for vehicles equipped with PRIMAAX® EX • FIREMAAX® EX rear suspensions.

Refer to the appropriate Hendrickson Technical Procedure and other publications for complete service and safety instructions regarding the particular PRIMAAX EX • FIREMAAX EX rear air suspension on your vehicle. All such Hendrickson publications are available online at [www.hendrickson-intl.com](http://www.hendrickson-intl.com)

### SERVICE HINT

Use the QUIK-ALIGN Pivot Bushing Tool No. 66086-203L to help with the installation and removal of QUIK-ALIGN pivot bushings. The tool allows the existing pivot bushing to be pushed out from the U-beam assembly into the receiving cylinder. Then follow a similar procedure to push in the replacement pivot bushing, see Figure 1.

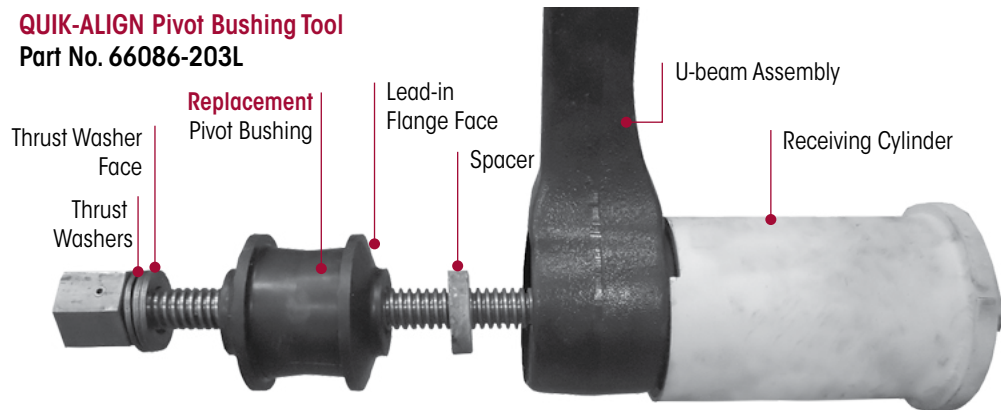
**FIGURE 1**

#### NOTE

**Apply NLGI #2-EP** chassis lubricant to each face of the thrust washers and to the drive screw that will engage through the receiving cylinder.

**Apply P80** lubricant to the face of the lead-in flange and the outer diameter of **NEW** pivot bushing

#### QUIK-ALIGN Pivot Bushing Tool Part No. 66086-203L



### U-BEAM ASSEMBLY REMOVAL

#### **WARNING**

A TECHNICIAN USING A SERVICE PROCEDURE OR TOOL WHICH HAS NOT BEEN RECOMMENDED BY HENDRICKSON MUST FIRST SATISFY HIMSELF THAT NEITHER HIS SAFETY NOR THE VEHICLE'S SAFETY WILL BE JEOPARDIZED BY THE METHOD OR TOOL SELECTED. INDIVIDUALS DEVIATING IN ANY MANNER FROM THE INSTRUCTIONS PROVIDED WILL ASSUME ALL RISKS OF CONSEQUENTIAL PERSONAL INJURY OR DAMAGE TO EQUIPMENT INVOLVED.

1. Remove the U-beam assembly from the vehicle per the U-beam Disassembly procedure in the appropriate PRIMAAX EX • FIREMAAX EX Technical Procedure available online at [www.hendrickson-intl.com](http://www.hendrickson-intl.com).
2. After removal, place U-beam assembly on the floor or suitable work area.



Pivot Bushing Service Kits – Axle Sets

**HEAVY-DUTY BUSHING**

1" Fasteners – Kit No. 60632-020



**SEVERE-DUTY BUSHING**

1" Fasteners – Kit No. 60632-043  
\*1 ¼" Fasteners – Kit No. 60632-033



NOTE \* Kit No. 60632-033 requires Hendrickson engineering approval.

**PIVOT BUSHING**

**NOTE**

When replacing a pivot bushing it is recommended to replace BOTH pivot bushings on the U-beam assembly.

To replace the QUIK-ALIGN pivot bushing you will need:

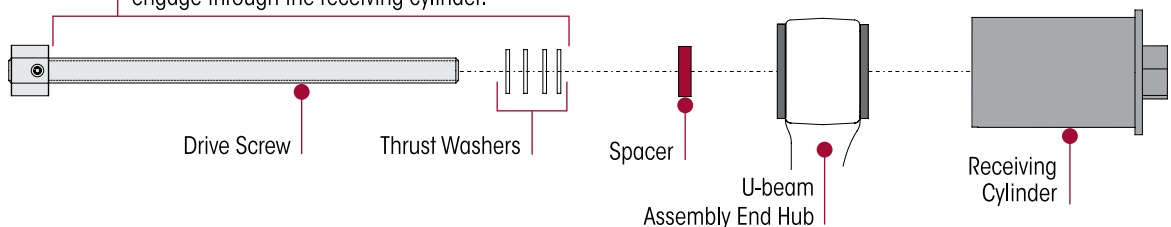
- QUIK-ALIGN pivot bushing tool ( Hendrickson Part No. 66086-203L), see Figure 1
- ¾" Impact wrench (impact gun), some ½" impact wrenches may work

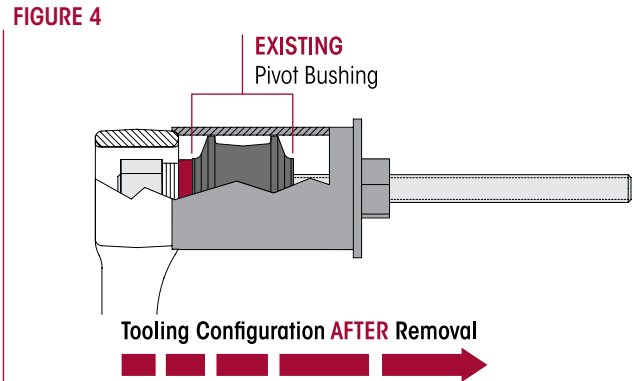
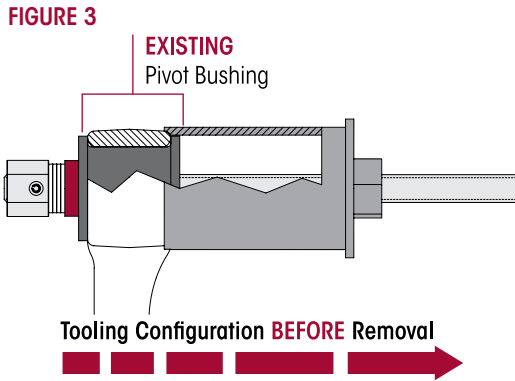
**REMOVAL**

1. Install the pivot bushing tool as shown in Figure 2.
2. Remove and discard thrust washers (if equipped) and any loose rubber or debris from the existing pivot bushing.
3. Apply NLGI #2–EP (Extreme Pressure) chassis lubricant to each face of the thrust washers and to the drive screw that will engage through the receiving cylinder, see Figure 2.
4. Snug the threaded drive screw to hold the thrust washers, spacer, U-beam assembly with the existing pivot bushing and the receiving cylinder in place, see Figure 3.
5. Using a ¾" impact wrench, rotate the drive screw in a continuous motion without stopping until the pivot bushing is removed from the end hub. The existing pivot bushing will enter into the receiving cylinder, see Figure 3.
6. Remove and discard pivot bushing.
7. Repeat steps 1 through 6 for other side of the U-beam assembly, as recommended.

**FIGURE 2**

Apply NLGI #2–EP chassis lubricant to each face of the thrust washers, and drive screw that will engage through the receiving cylinder.





**END HUB INSPECTION**

1. Inspect the inner bore of the U-beam assembly end hub and remove any loose debris or rubber residue from the bushing mating surface.

**INSTALLATION**

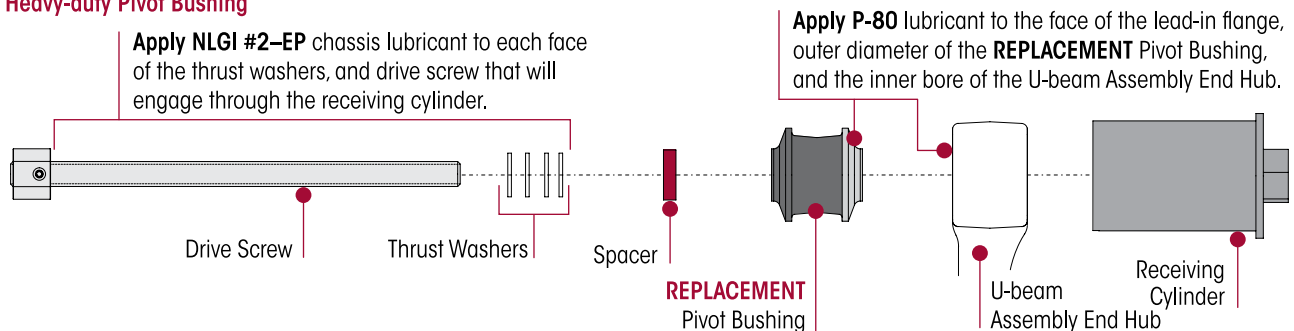
1. Clean the inner diameter of the U-beam assembly end hub with brake cleaner.
2. Apply NLGI #2-EP (Extreme Pressure) chassis lubricant to each face of the thrust washers and to the drive screw that will engage through the receiving cylinder, see Figure 5.

**NOTE**

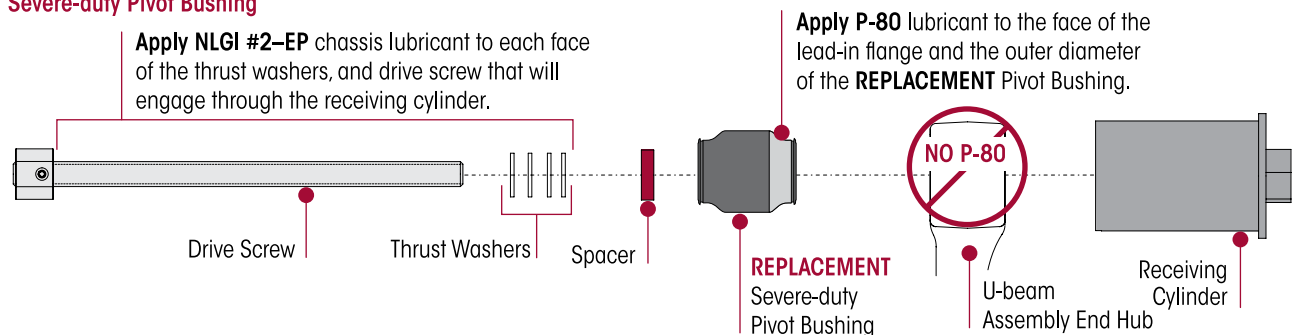
**DO NOT** use petroleum or soap base lubricant, it can cause an adverse reaction with the bushing material, such as deterioration. P-80 lubricant is supplied in the QUIK-ALIGN Pivot Bushing Kits.

3. Apply P-80 lubricant to the:
  - **Heavy-duty Pivot Bushing** – the face of the lead-in flange, to the outer diameter of the replacement pivot bushing and to the inner diameter of the U-beam assembly end hub, see Figure 5.
  - **Severe-duty Pivot Bushing** – the face of the lead-in flange and to the outer diameter of the severe-duty pivot bushing, see Figure 6. **DO NOT** apply to U-beam end hub.

**FIGURE 5**  
Heavy-duty Pivot Bushing



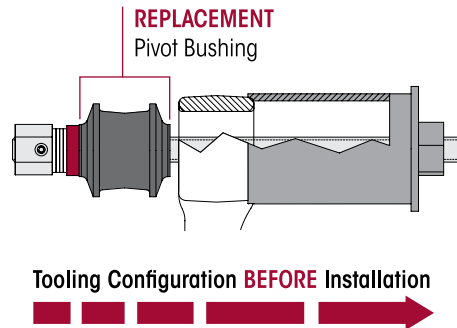
**FIGURE 6**  
Severe-duty Pivot Bushing



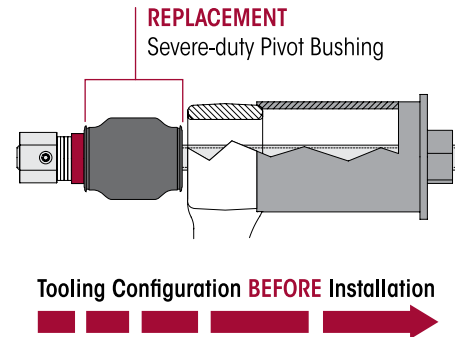


- Snug the threaded drive screw to hold the thrust washers, spacer, pivot bushing, and U-beam assembly with the receiving cylinder in place, see Figures 7 and 8.
- Using a 3/4" impact wrench, rotate the drive screw in a continuous motion without stopping until the pivot bushing is seated in the hub and slightly overshoots the opposite end of the hub. It is necessary to overshoot the desired final position, see Figures 9 and 10.

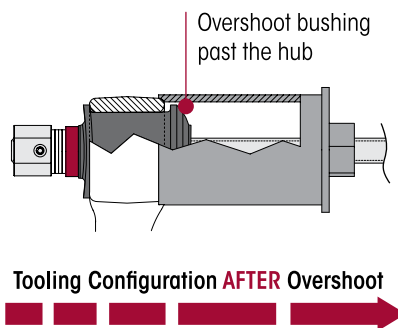
**FIGURE 7**  
Heavy-duty Pivot Bushing



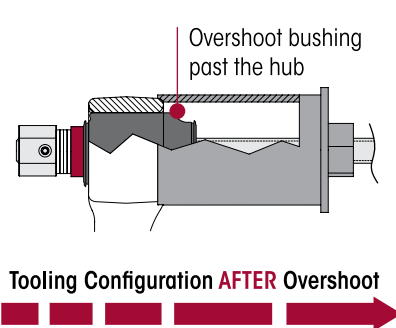
**FIGURE 8**  
Severe-duty Pivot Bushing



**FIGURE 9**  
Heavy-duty Pivot Bushing

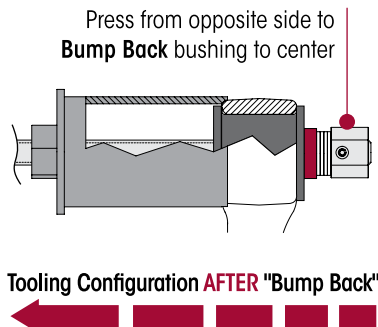


**FIGURE 10**  
Severe-duty Pivot Bushing

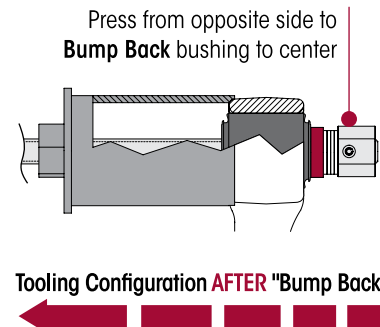


- Remove and reverse the installation tool, then from opposite side of the hub press the pivot bushing again to center the bushing within the beam end hub, see Figures 11 and 12. Center the pivot bushing to help prevent bulging and bushing preload. This is known as the "Bump Back" procedure.

**FIGURE 11**  
Heavy-duty Pivot Bushing



**FIGURE 12**  
Severe-duty Pivot Bushing



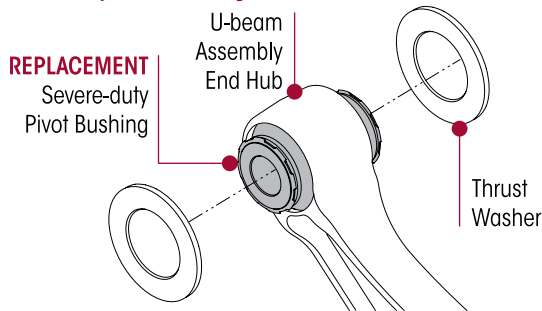
**SERVICE HINT**

If the **severe-duty pivot bushing** comes out of the opposite end of the end hub during installation, less P-80 lubricant is required. Repeat the installation procedure ensure only a light amount of lubricant is on the bushing itself.

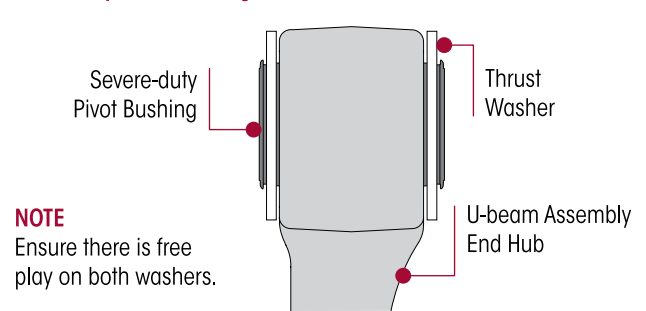


7. **Severe-duty Pivot Bushings** – Snap the thrust washers onto the bushing, (see Figure 13) and ensure there is free play on both washers, see Figure 14. If one washer does not seat properly or is very snug use a dead blow hammer to center the bushing. If a dead blow hammer is not sufficient, the installation tool must be used to perform a secondary "Bump Back" procedure to center the bushing, refer to step 6 and see Figure 12.
8. Repeat for the other side of the U-beam assembly, as recommended:
  - **Heavy-duty Pivot Bushings** – Steps 1 through 6.
  - **Severe-duty Pivot Bushings** – Steps 1 through 7.
9. Allow the lubricant four (4) hours to dissipate before fully operating the vehicle.

**FIGURE 13**  
Severe-duty Pivot Bushing



**FIGURE 14**  
Severe-duty Pivot Bushing



**U-BEAM ASSEMBLY INSTALLATION**

1. Follow the U-beam assembly installation procedure as detailed in the appropriate PRIMAAX EX • FIREMAAX EX Technical Procedures for your vehicle available online at [www.hendrickson-intl.com](http://www.hendrickson-intl.com).

Refer any questions on this publication to Hendrickson Tech Services.



Toll-free U.S. and Canada  
1.866.755.5968  
Outside U.S. and Canada  
1.630.910.2800



Parts Identification  
[truckparts@hendrickson-intl.com](mailto:truckparts@hendrickson-intl.com)  
Technical Support  
[techservices@hendrickson-intl.com](mailto:techservices@hendrickson-intl.com)



1.630.910.2899



Additional Hendrickson  
Product Information  
[www.hendrickson-intl.com](http://www.hendrickson-intl.com)

Actual product performance may vary depending upon vehicle configuration, operation, service and other factors.  
All applications must comply with applicable Hendrickson specifications and must be approved by the respective vehicle manufacturer with the vehicle in its original, as-built configuration.  
Contact Hendrickson for additional details regarding specifications, applications, capacities, and operation, service and maintenance instructions.

*Call Hendrickson at **1.866.755.5968** (toll-free) or **1.630.910.2800** for additional information.*



[www.hendrickson-intl.com](http://www.hendrickson-intl.com)

**TRUCK COMMERCIAL VEHICLE SYSTEMS**  
800 South Frontage Road  
Woodridge, IL 60517-4904 USA  
1.866.755.5968 (Toll-free U.S. and Canada)  
1.630.910.2800 (Outside U.S. and Canada)  
Fax 1.630.910.2899

59310-061 Rev C 2-23

© 2014-2023 Hendrickson USA, L.L.C. All Rights Reserved. All trademarks shown are owned by Hendrickson USA, L.L.C., or one of the affiliates, in one or more countries.  
Information contained in this literature was accurate at the time of publication. Product changes may have been made after the copyright date that are not reflected.

Printed in United States of America