

QUIK-DRAW®

Pneumatic Pin-Pull Mechanism

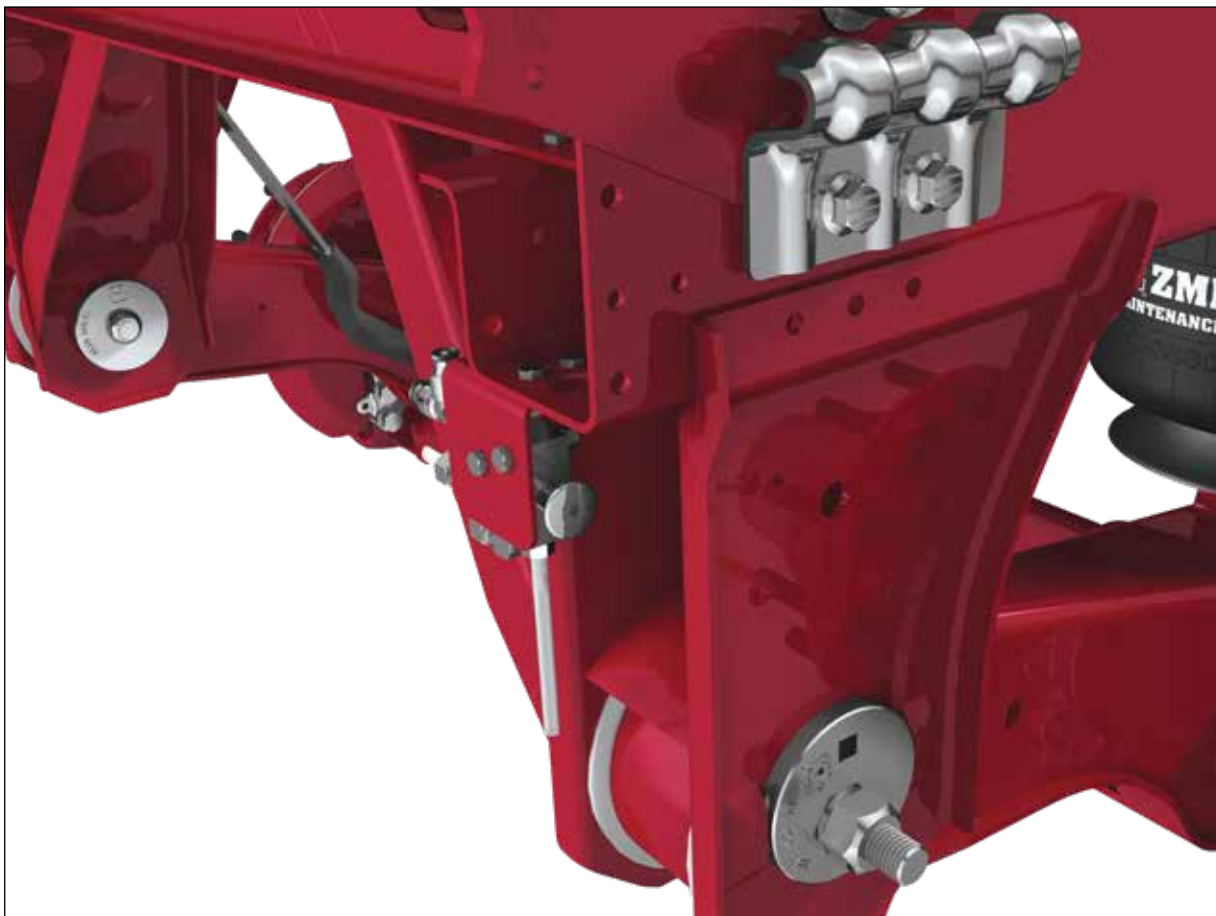

- Fully pneumatic pin-pull mechanism
- Fingertip operation
- Fast, efficient slider repositioning



Fingertip Operation

QUIK-DRAW® makes the true fingertip slider pin release a reality on VANTRAAX® and ULTRAA-K® van and reefer slider systems and INTRAAX® SP platform slider systems. Triggered with a simple pull of a knob, QUIK-DRAW enhances driver productivity and satisfaction. The patented QUIK-DRAW system remains the market's only completely pneumatic pin-pull mechanism, delivering significant weight savings over other mechanically assisted pin-pull devices.

Fast, Efficient Slider Repositioning

When activated, QUIK-DRAW applies continuous pressure until the pins release, reducing repositioning to a one-person exercise by tapping into the trailer's air power. Saving drivers from tugging, jerking and hammering locked or jammed slider pins. As an additional security measure, pins automatically reset with the release of the emergency brake. QUIK-DRAW releases the pins in seconds to help ensure faster and more efficient slider repositioning to get rigs back on the road sooner.

To learn more about QUIK-DRAW, call 866.743.3247
or visit www.hendrickson-intl.com

 **HENDRICKSON**
The World Rides On Us®

QUIK-DRAW® Pin-Pull Mechanism Features and Benefits

Increases Productivity

Keeping drivers and equipment on the road increases fleets' bottom lines. QUIK-DRAW® helps save time with every slider repositioning. When activated, the system applies continuous pressure until pins are free.

Boosts Driver Efficiency and Satisfaction

With simple fingertip activation, QUIK-DRAW prevents drivers from wrestling to free locked slider pins. As an additional feature, pins automatically reset with the release of the trailer emergency brakes – a feature not available on other pin release designs.

Hendrickson Durability

Valves are tested to meet stringent durability and environmental conditions, operating in temperatures to minus 40 degrees. The Hendrickson name guarantees the same high quality and proven durability you demand from our suspensions.



QUIK-DRAW Actuator

VANTRAAX® and ULTRAA-K® – HKA

QUIK-DRAW features linear actuators manufactured from the same rugged material as an air spring. Actuators are tucked inside the slider frame to protect them from road debris.



INTRAAX® SP – AAZ MODELS

Platform slider operators enjoy the same pin-pulling benefits as VANTRAAX users. QUIK-DRAW for sliding flats features a proven air chamber actuator with automatic reset, which fits neatly inside the slider cross member for added protection.

Actual product performance may vary depending upon vehicle configuration, operation, service and other factors.
All applications must comply with applicable Hendrickson specifications and must be approved by the respective vehicle manufacturer with the vehicle in its original, as-built configuration.
Contact Hendrickson for additional details regarding specifications, applications, capacities, operation, service and maintenance instructions.

Call Hendrickson at **866.RIDEAIR (743.3247)** for additional information.



www.hendrickson-intl.com



TRAILER COMMERCIAL VEHICLE SYSTEMS
2070 Industrial Place SE
Canton, OH 44707-2641 USA
866.RIDEAIR (743.3247)
Fax 800.696.4416

HENDRICKSON CANADA ULC
2825 Argentina Road, Unit #1 - 4
Mississauga, ON Canada L5N 8G6
800.668.5360
905.789.1030 • Fax 905.812.9423

HENDRICKSON MEXICANA
Circuito El Marqués Sur #29
Parque Industrial El Marqués
Pob. El Colorado, Municipio El Marqués,
Querétaro, México CP 76246
+52 442.296.3600 • Fax +52 442.296.3601

L628 Rev I 05-25

© 1998 - 2025 Hendrickson USA, L.L.C. All Rights Reserved. All trademarks shown are owned by Hendrickson USA, L.L.C., or one of its affiliates, in one or more countries. Information contained in this literature was accurate at the time of publication.
Product changes may have been made after the copyright date that are not reflected. Printed in United States of America