



H TECHNICAL PROCEDURE

COMOSILITE® EXF: NON-STEERABLE AUXILIARY AXLE SUSPENSION SYSTEMS

SUBJECT: OWNER'S MANUAL

LIT NUMBER: H818

DATE: June 2023

REV: C

TABLE OF CONTENTS

Section 1	Introduction	2	Section 11	Torque Specifications	29
Section 2	Product Description	3	Section 12	Trouble-Shooting Guide	30
	Identifying Your Lift Axle Suspension	3	Section 13	Approved Wheel-Ends	31
Section 3	Important Safety Notice	4	Section 14	Trailer Mount Drawings	33
Section 4	Special Tools	8			
Section 5	Pre-Installation Topics	9			
	Driveline Clearance	9			
	lift axle location	10			
	Ride Height & Frame Width	11			
Section 6	Installation	12			
	Truck Installation	12			
	Final Assembly Checklist	14			
	Trailer Installation (Bolt-On)	15			
	Final Assembly Checklist	16			
	Trailer Installation (Weld-On)	17			
	Final Assembly Checklist	18			
Section 7	Lift Axle Alignment	20			
Section 8	Lift Axle Operation	22			
	Inside/Outside-Mounted Air Control Kits	22			
	Raising The Lift Axle	22			
	Lowering The Lift Axle	22			
	Navigating a 90-Degree Curve or Turn	22			
Section 9	Air Pressure Loads	23			
Section 10	Preventive Maintenance	25			
	Daily/Pre-Trip Operator Inspection	25			
	General Inspection	25			
	Component Inspection	26			
	Tire Inspection	26			

SECTION 1 INTRODUCTION

Hendrickson Technical Publication TP-H818 is intended as a product overview covering installation, operation and preventive maintenance for Hendrickson's COMPOSILITE® EXF Non-Steerable, Auxiliary Lift-Axle Suspension Systems for truck and trailer applications.

In the interest of simplicity, consistency and clarity, throughout this publication the term "Lift Axle" will serve in place of the full product description of "COMPOSILITE® EXF Non-Steerable, Auxiliary Lift-Axle Suspension System". "Lift axle" is to be understood as the entire lift axle system as shipped from the factory, not simply the axle beam or any other interpretation.

IMPORTANT!

INSTALLATION, OPERATION AND PREVENTIVE MAINTENANCE OF A LIFT AXLE REQUIRES A CERTAIN DEGREE OF EXPERTISE AND OFTEN SPECIALIZED TOOLING AND EQUIPMENT; INEXPERIENCED AND NON-QUALIFIED INDIVIDUALS SHOULD NOT UNDERTAKE THE PROCEDURES DESCRIBED IN THIS PUBLICATION. THE QUALIFIED INSTALLER/OWNER OPERATOR MUST READ TECHNICAL PUBLICATION TP-H818 THOROUGHLY BEFORE PROCEEDING WITH ANY INSTALLATION, OPERATION, OR PREVENTIVE MAINTENANCE PROCEDURES. REFER TO HENDRICKSON PUBLICATION [TP-H825](#) (INSTALLATION INSERT) FOR DIMENSIONS USED DURING PRE-INSTALLATION AND INSTALLATION PROCEDURES.

 **WARNING**

BEFORE BEGINNING THE INSTALLATION PROCESS, VERIFY THAT YOUR LIFT AXLE MEETS THE REQUIREMENTS OF YOUR INTENDED VEHICLE AND APPLICATION: ACTUAL PRODUCT PERFORMANCE MAY VARY DEPENDING UPON VEHICLE CONFIGURATION, OPERATION, SERVICE AND OTHER FACTORS. ALL APPLICATIONS MUST COMPLY WITH APPLICABLE HENDRICKSON SPECIFICATIONS AND MUST BE APPROVED BY THE RESPECTIVE VEHICLE MANUFACTURER WITH THE VEHICLE IN ITS ORIGINAL, AS-BUILT CONFIGURATION. ANY LIFT-AXLE'S WEIGHT RATING IS LIMITED BY THE LOWEST RATING OF ANY CONSTITUENT COMPONENT INSTALLED INTO OR ONTO THAT LIFT AXLE. THE TIRE AND RIM SPECIFICATIONS, ORIENTATION AND LOAD LOCATION CAN ALSO AFFECT THE RATING OF THE HUBS AND HENCE THE LIFT AXLE'S RATING AS A WHOLE. IT IS THE INSTALLER'S RESPONSIBILITY TO ENSURE THAT THE LIFT AXLE'S RATING (WHICH MAY BE REDUCED, AS INDICATED ABOVE) IS NOT EXCEEDED. FAILURE TO DO THIS CAN RESULT IN DAMAGE TO THE LIFT AXLE. A PARTICULAR CONCERN IS THE POSSIBLE "DE-RATING" OF SUSPENSION CAPACITY WHEN USING OFFSET (DISHED-OUT OR DISHED-IN) WHEELS, A SITUATION THAT CAN PUT AN EXCESSIVE LOAD ON THE BEARINGS AND SPINDLE, WHICH CAN LEAD TO REDUCED SERVICE LIFE AND MECHANICAL FAILURES. WHEN UTILIZING HUBS, WHEELS OR BEARINGS NOT SUPPLIED BY OR RECOMMENDED BY HENDRICKSON OR WHEN REPLACING HENDRICKSON-SUPPLIED HUBS AND/OR BEARINGS WITH COMPONENTS NOT SUPPLIED BY HENDRICKSON, IT IS THE BUYER'S RESPONSIBILITY TO CONSULT WITH THE SUPPLIERS OF THOSE COMPONENTS AND ALL ASSOCIATED SUPPLIER LITERATURE TO ASSURE THAT THE RATED CAPACITY OF THE LIFT-AXLE OR ITS SUB-ASSEMBLIES WILL NOT BE EXCEEDED.

Contact Hendrickson Customer Service for additional details regarding specifications, applications, capacities, operation, service and maintenance: 800-660-2829 (toll-free in US and Canada), 740-929-5600 or liftaxle@hendrickson-intl.com.

All parts being considered in any warranty claim are subject to return to Hendrickson for evaluation.

The latest revision of Technical Publication TP-H818 and other Hendrickson publications are available online at <https://www.hendrickson-intl.com/Auxiliary>.

SECTION 2 PRODUCT DESCRIPTION

COMPOSILITE® EXF is Hendrickson's next generation of light-weight, durable, non-steerable lift axle. A number of technological advancements enabled Hendrickson to take this concept from theory to the road. Inset lower beams help optimize lateral stiffness and eliminate the need for V-rods, and zero-torsion rubber bushings provide increased bushing life, to help lower the cost of ownership and down-time. The EXF bolt-on axle seats have no seat-to-axle welds and are easier to service and replace for ride-height re-configurations. In addition, the upper aluminum beams help reduce weight without sacrificing durability.

A 7-year structural limited warranty accompanies the COMPOSILITE® EXF. See Hendrickson publications TP-H624 (Hendrickson Auxiliary Lift-Axle Suspensions: Limited Warranty) and TP-H800 (Hendrickson Warranty Claim Request Form), which are available at www.hendrickson-intl.com.

TABLE 2-1: COMPOSILITE® EXF SPECIFICATIONS

SUSPENSION	CAPACITY
TRUCK APPLICATIONS:	
EXF	13.5k (FF spindle)
EXF Roll-off	13.5k (FF spindle)
TRAILER APPLICATIONS:	
EXF Weld-on	13.5k (FF/N spindles); 13.2k (P spindle) 12.2k (P spindle MAXX22T Air Disc); 11k (P spindle Bendix ADB22X Air Disc)
EXF Bolt-on	13.5k (FF/N spindles); 13.2 (P spindle) 12.2k (P spindle MAXX22T Air Disc); 11k (P spindle Bendix ADB22X Air Disc)

IMPORTANT!

SEE SECTION 13 OF THIS DOCUMENT FOR MORE DETAILED INFORMATION ABOUT LIFT-AXLE RATING BASED ON APPROVED WHEEL-END CONFIGURATIONS.

IDENTIFYING YOUR LIFT AXLE SUSPENSION

The Serial Number Plate shown below is a stainless steel tag attached to the frame of the lift axle. It includes a Model Number (MDL) (i.e. an "as-built" reference number) and a Serial Number (S/N) that is a unique identifier for each Hendrickson lift axle. These two numbers are important to have when contacting Hendrickson Customer Service for replacement parts, warranty claims, and regarding other inquiries.

Figure 2-1 below shows the latest format (as of July 2020) of the Hendrickson Serial Number Plate.

FIGURE 2-1: HENDRICKSON SERIAL NUMBER PLATE

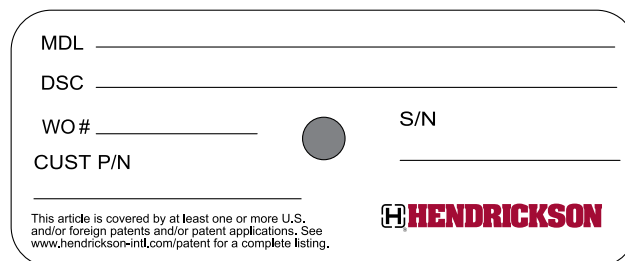

SECTION 3

IMPORTANT SAFETY NOTICE

Proper installation, maintenance, service, and repair is important for the reliable operation of the lift axle. The procedures recommended by Hendrickson and described in this technical publication are methods of performing such installation, maintenance, service and repair.

All safety-related information should be read carefully to help prevent personal injury and to assure that proper methods are used. Improper installation, maintenance, service or repair may damage the vehicle, cause personal injury, render it unsafe in operation, or void the manufacturer's warranty.

Failure to follow the safety precautions in this manual can result in personal injury and/or property damage. Carefully read and understand all safety-related information within this publication, on all decals, and in all such materials provided by the vehicle manufacturer before conducting any installation, maintenance, service or repair.

EXPLANATION OF SIGNAL WORDS

Hazard "Signal Words" (Danger! Warning! Caution!) appear in various locations throughout this publication. Information accented by one of these signal words must be observed to help minimize the risk of personal injury to service personnel, or possibility of improper service methods which may damage the vehicle or render it unsafe.



This is the safety alert symbol. It is used to alert you to potential personal injury hazards. Obey all safety messages that follow this symbol to avoid possible injury or death.

Additional Notes or Service Hints are utilized to emphasize areas of procedural importance and provide suggestions for ease of repair. The following definitions indicate the use of these signal words as they appear throughout the publication.



INDICATES AN IMMINENTLY HAZARDOUS SITUATION, WHICH, IF NOT AVOIDED, WILL RESULT IN SERIOUS INJURY OR DEATH.



INDICATES A POTENTIAL HAZARDOUS SITUATION, WHICH, IF NOT AVOIDED, CAN RESULT IN SERIOUS INJURY OR DEATH.



INDICATES A POTENTIAL HAZARDOUS SITUATION, WHICH, IF NOT AVOIDED, MAY RESULT IN MINOR OR MODERATE INJURY.

NOTE: AN OPERATING PROCEDURE, PRACTICE CONDITION, ETC., WHICH IS ESSENTIAL TO EMPHASIZE.

SERVICE HINT: A HELPFUL SUGGESTION THAT WILL MAKE THE SERVICE BEING PERFORMED A LITTLE EASIER AND / OR FASTER.



The torque symbol alerts you to tighten fasteners to a specified torque value. Refer to the Torque Specifications section of this publication.

SAFETY PRECAUTIONS



LIFT AXLE RAPID MOVEMENT

LIFT AXLE RAPID MOVEMENT CAN CAUSE SEVERE PERSONAL INJURY OR DEATH.

IF LIFT AXLE IS OPERATED BY AN AUTOMATIC OR SEMI-AUTOMATIC LIFT AXLE CONTROL SYSTEM, SUCH SYSTEM MAY CAUSE LIFT AXLE TO RAISE OR LOWER AUTOMATICALLY UNDER DIFFERENT CONDITIONS.

LIFT AXLE ACTIVATION AND MOVEMENT MAY VARY DEPENDING ON THE BRAND, CONFIGURATION, AND OPERATING CONDITION OF THE LIFT AXLE CONTROL SYSTEM AND/OR OTHER FACTORS. READ, UNDERSTAND, AND COMPLY WITH ALL APPLICABLE OPERATING INSTRUCTIONS AND SAFETY INFORMATION PROVIDED BY THE LIFT AXLE CONTROL SYSTEM MANUFACTURER AND VEHICLE MANUFACTURER. ENSURE ALL PERSONNEL ARE CLEAR OF LIFT AXLE BEFORE AND DURING VEHICLE LOADING AND LIFT AXLE ACTIVATION UP OR DOWN.

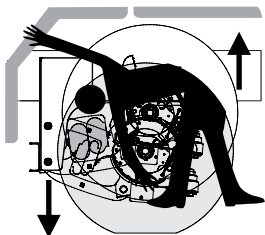



CAUTION

LIFT AXLE ACTIVATION

DO NOT LOWER THE LIFT AXLE WHILE THE VEHICLE IS MOVING IN REVERSE OR TRAVELING FORWARD AT MORE THAN 15 MPH. FAILURE TO COMPLY WITH THIS RULE CAN CAUSE COMPONENT DAMAGE.

CAUTION

NAVIGATING A 90-DEGREE CURVE OR TURN

TO MINIMIZE PREMATURE TIRE WEAR OR POSSIBLE DAMAGE TO NON-STEERABLE LIFT AXLE COMPONENTS (IF APPLICABLE), THE LIFT AXLE MAY BE RAISED TO THE UP POSITION PRIOR TO NAVIGATING A 90 DEGREE OR TIGHTER CURVE OR TURN. COMPLY WITH ALL FEDERAL, STATE / PROVINCIAL AND / OR LOCAL WEIGHT, DIMENSION AND CONFIGURATION REGULATIONS UNDER LOADED AND UNLOADED CONDITIONS.

WARNING

LOAD CAPACITY

ADHERE TO THE PUBLISHED CAPACITY RATINGS FOR THE AUXILIARY LIFT AXLE. ADD-ON AXLE ATTACHMENTS (I.E. SLIDING FIFTH WHEELS) AND OTHER LOAD TRANSFERRING DEVICES CAN INCREASE THE AUXILIARY AXLE LOAD ABOVE THE RATED AND APPROVED CAPACITIES WHICH CAN RESULT IN FAILURE AND ADVERSE VEHICLE HANDLING, POSSIBLY CAUSING PERSONAL INJURY OR PROPERTY DAMAGE.

CAUTION

DAILY / PRE-TRIP OPERATOR INSPECTION

DAILY (AND BEFORE EACH TRIP) INSPECT ALL LIFT AXLE COMPONENTS FOR PROPER OPERATING CONDITION AND PROPER INSTALLATION TO THE TRUCK / TRAILER FRAME. THIS ESSENTIAL DAILY / PRE-TRIP OPERATOR INSPECTION MUST ALSO INCLUDE A VISUAL INSPECTION OF ALL WHEEL SEALS AND GASKETS FOR LEAKS, A VERIFICATION OF PROPER OIL LEVEL IN THE HUBS (IF APPLICABLE), INSPECTION OF ALL LIFT AND RIDE AIR SPRINGS FOR WEAR, AND INSPECTION OF ALL TIRES FOR PROPER INFLATION AND ABNORMAL WEAR PATTERNS. IDENTIFY AND REPAIR / REPLACE ANY LOOSE, DAMAGED OR IMPROPERLY INSTALLED COMPONENTS. FOR ADDITIONAL SERVICE, REPAIR, AND REBUILD INSTRUCTIONS, REFER TO THE CURRENT VERSION OF OTHER HENDRICKSON PUBLICATIONS THAT APPLY TO YOUR PARTICULAR LIFT AXLE SUSPENSION. SUCH PUBLICATION NUMBERS MAY INCLUDE, BUT ARE NOT LIMITED TO [OM-H757](#), WHICH IS AVAILABLE ONLINE AT WWW.HENDRICKSON-INTL.COM.

WARNING

REPAIR AND RECONDITIONING

THE REPAIR OR RECONDITIONING OF LIFT AXLE COMPONENTS THAT ARE BENT, DAMAGED OR OUT OF SPECIFICATION IS NOT ALLOWED. ANY LIFT AXLE COMPONENTS FOUND TO BE DAMAGED OR OUT OF SPECIFICATION MUST BE REPLACED. LIFT AXLE COMPONENTS CANNOT BE BENT, WELDED, HEATED OR REPAIRED WITHOUT REDUCING THE STRENGTH OR LIFE OF THE COMPONENT. FAILURE TO FOLLOW THESE GUIDELINES CAN CAUSE ADVERSE VEHICLE HANDLING, POSSIBLE PERSONAL INJURY, DEATH OR PROPERTY DAMAGE AND WILL VOID APPLICABLE WARRANTIES.

WARNING

PERSONNEL PROTECTIVE EQUIPMENT

ALWAYS WEAR PROPER EYE PROTECTION AND OTHER REQUIRED PERSONAL PROTECTIVE EQUIPMENT TO HELP PREVENT PERSONAL INJURY WHEN YOU PERFORM VEHICLE MAINTENANCE, REPAIR OR SERVICE.

CAUTION

PROCEDURES AND TOOLS

A MECHANIC PERFORMING A SERVICE PROCEDURE OR USING A TOOL THAT HAS NOT BEEN RECOMMENDED BY HENDRICKSON MUST FIRST ASSURE HIMSELF THAT NEITHER HIS SAFETY NOR THE VEHICLE'S SAFETY WILL BE JEOPARDIZED BY THE METHOD OR TOOL SELECTED. INDIVIDUALS DEVIATING IN ANY MANNER FROM THE INSTRUCTIONS PROVIDED ASSUME ALL RISKS OF POTENTIAL PERSONAL INJURY OR DAMAGE TO EQUIPMENT INVOLVED.

WARNING

FASTENERS

DISCARD USED FASTENERS. ALWAYS USE NEW FASTENERS TO COMPLETE A REPAIR. FAILURE TO DO SO COULD RESULT IN FAILURE OF THE PART OR MATING COMPONENTS, ADVERSE VEHICLE HANDLING, PERSONAL INJURY, OR PROPERTY DAMAGE. LOOSE OR OVER-TORQUED FASTENERS CAN CAUSE COMPONENT DAMAGE, ADVERSE VEHICLE HANDLING, PROPERTY DAMAGE, OR SEVERE PERSONAL INJURY. MAINTAIN CORRECT TORQUE VALUE AT ALL TIMES. CHECK TORQUE VALUES ON A REGULAR BASIS AS SPECIFIED, USING A REGULARLY CALIBRATED TORQUE WRENCH. TORQUE VALUES SPECIFIED IN THIS TECHNICAL PUBLICATION ARE FOR HENDRICKSON-SUPPLIED FASTENERS ONLY. IF NON-HENDRICKSON FASTENERS ARE USED, FOLLOW TORQUE SPECIFICATIONS FROM THE FASTENER MANUFACTURER.

 **WARNING****MODIFYING COMPONENTS**

DO NOT MODIFY OR REWORK PARTS WITHOUT AUTHORIZATION FROM HENDRICKSON. DO NOT SUBSTITUTE REPLACEMENT COMPONENTS NOT AUTHORIZED BY HENDRICKSON. USE OF MODIFIED, REWORKED, SUBSTITUTE OR REPLACEMENT PARTS NOT AUTHORIZED BY HENDRICKSON MAY NOT MEET HENDRICKSON'S SPECIFICATIONS AND CAN RESULT IN FAILURE OF THE PART, ADVERSE VEHICLE HANDLING, POSSIBLE PERSONAL INJURY OR PROPERTY DAMAGE, AND WILL VOID APPLICABLE WARRANTIES. USE ONLY HENDRICKSON-AUTHORIZED REPLACEMENT PARTS.

THE VEHICLE MANUFACTURER SHOULD BE CONSULTED BEFORE MAKING ANY CHANGES TO THE VEHICLE'S FRAME. TYPICALLY, CUTTING OR ALTERING THE VEHICLE'S FRAME OR SIDE RAIL IS NOT PERMITTED AND MAY AFFECT THE MANUFACTURER'S WARRANTY COVERAGE.

ANY INSTALLATION DEVIATIONS MUST BE APPROVED IN WRITING BY HENDRICKSON'S PRODUCT ENGINEERING DEPARTMENT. FAILURE TO COMPLY WITH ANY OF THE ABOVE WILL VOID APPLICABLE WARRANTIES.

 **WARNING****DAMAGED AXLE COMPONENTS**

IF A VEHICLE EQUIPPED WITH A HENDRICKSON LIFT AXLE IS INVOLVED IN A CRASH, A THOROUGH INSPECTION OF THE LIFT AXLE MUST BE PERFORMED NOTING THE CONDITION OF THE AXLE BEAM, KINGPINS, AND KNUCKLE ASSEMBLIES, INCLUDING THE AREAS OF AXLE-TO-KINGPIN INTERFACE, FOR ANY DAMAGE, GAPS, KINGPIN MOVEMENT OR PLAY. IF ANY COMPONENT APPEARS DAMAGED, OR THE KINGPINS APPEAR TO CONTAIN ANY DAMAGE, GAPS, MOVEMENT OR PLAY, THE COMPLETE AXLE ASSEMBLY MUST BE REPLACED.

IN ADDITION, IN THE EVENT A CRASH RESULTS IN EXCESSIVE SIDE LOAD DAMAGE TO ADJACENT PARTS, SUCH AS A BENT WHEEL, HUB, OR SPINDLE, IT IS STRONGLY RECOMMENDED TO REPLACE SUCH ADJACENT PARTS AND THE COMPLETE LIFT AXLE ASSEMBLY.

CONTACT HENDRICKSON TECHNICAL SERVICES DEPARTMENT WITH ANY QUESTIONS. FAILURE TO REPLACE ANY DAMAGED COMPONENTS CAN CAUSE ADVERSE VEHICLE HANDLING, POSSIBLE PERSONAL INJURY, DEATH, OR PROPERTY DAMAGE AND WILL VOID ANY APPLICABLE WARRANTIES.

 **WARNING****LIFT AXLE CAMBER**

UNAUTHORIZED WELDING OR MODIFICATIONS CAN CAUSE CRACKS OR OTHER LIFT AXLE STRUCTURAL DAMAGE AND RESULT IN ADVERSE VEHICLE HANDLING, SEVERE PERSONAL INJURY OR DEATH. DO NOT BEND, WELD OR MODIFY AXLE WITHOUT AUTHORIZATION FROM HENDRICKSON. AXLE CAMBER IS NOT ADJUSTABLE. DO NOT CHANGE THE AXLE CAMBER ANGLE OR BEND THE AXLE BEAM. BENDING THE AXLE BEAM TO CHANGE THE CAMBER ANGLE CAN DAMAGE THE AXLE AND REDUCE AXLE STRENGTH, CAN CAUSE ADVERSE VEHICLE HANDLING, POSSIBLY CAUSING PERSONAL INJURY OR PROPERTY DAMAGE AND WILL VOID APPLICABLE WARRANTIES.

 **WARNING****IMPROPER JACKING METHOD**

IMPROPER JACKING METHOD CAN CAUSE STRUCTURAL DAMAGE AND RESULT IN ADVERSE VEHICLE HANDLING, SEVERE PERSONAL INJURY OR DEATH. DO NOT USE AXLE BEAM OUTBOARD OF AXLE SPRING SEATS. REFER TO VEHICLE MANUFACTURER FOR PROPER JACKING INSTRUCTIONS.

 **WARNING****SUPPORT THE LIFT AXLE PRIOR TO SERVICING**

PLACE THE VEHICLE/TRAILER ON A LEVEL FLOOR AND CHOCK THE WHEELS TO HELP PREVENT THE VEHICLE / TRAILER FROM MOVING. PRIOR TO SERVICING A LIFT AXLE IN THE RAISED POSITION, (1) PROPERLY SUPPORT THE LIFT AXLE WITH SAFETY STANDS AND (2) RELEASE ALL AIR PRESSURE IN LIFT AXLE'S AIR SPRINGS AND RIDE SPRINGS. DO NOT WORK AROUND OR UNDER A RAISED LIFT AXLE SUPPORTED ONLY WITH FLOOR JACKS OR OTHER LIFTING DEVICES. FAILURE TO DO SO CAN CAUSE DEATH, PERSONAL INJURY OR DAMAGE TO COMPONENTS.

 **WARNING****SUPPORT THE VEHICLE PRIOR TO SERVICING**

PLACE THE VEHICLE ON A LEVEL FLOOR AND CHOCK THE WHEELS TO HELP PREVENT THE VEHICLE FROM MOVING. PRIOR TO SERVICING A VEHICLE IN THE RAISED POSITION, PROPERLY SUPPORT THE VEHICLE WITH SAFETY STANDS. DO NOT WORK AROUND OR UNDER A RAISED VEHICLE SUPPORTED ONLY WITH FLOOR JACKS OR OTHER LIFTING DEVICES, FAILURE TO DO SO CAN CAUSE DEATH, PERSONAL INJURY OR DAMAGE TO COMPONENTS.

WARNING**AIR SPRINGS**

AIR SPRING ASSEMBLIES MUST BE DEFLATED PRIOR TO LOOSENING ANY ADJACENT HARDWARE. UNRESTRICTED AIR SPRING ASSEMBLIES CAN VIOLENTLY SHIFT. DO NOT INFLATE AIR SPRING ASSEMBLIES WHEN THEY ARE UNRESTRICTED. AIR SPRING ASSEMBLIES MUST BE RESTRICTED BY SUSPENSION OR OTHER ADEQUATE STRUCTURE. DO NOT INFLATE BEYOND PRESSURES RECOMMENDED BY AIR SPRING MANUFACTURER. CONTACT HENDRICKSON TECHNICAL SERVICES FOR DETAILS. IMPROPER USE OR OVER INFLATION MAY CAUSE AIR SPRING ASSEMBLIES TO BURST, CAUSING PROPERTY DAMAGE AND / OR SEVERE PERSONAL INJURY.

WARNING**AIR SPRINGS**

EXHAUST ALL PRESSURE IN THE LIFT AXLE'S AIR SPRINGS AND VEHICLE AIR SYSTEM BEFORE WORKING ON OR AROUND THE LIFT AXLE. FAILURE TO DO SO CAN CAUSE SEVERE PERSONAL INJURY OR DEATH.

WARNING**AIR SPRINGS**

PRIOR TO AND DURING DEFLATION AND INFLATION OF THE AIR SUSPENSION SYSTEM, ENSURE THAT ALL PERSONNEL AND EQUIPMENT ARE CLEAR FROM UNDER THE VEHICLE AND AROUND THE SERVICE AREA. FAILURE TO DO SO CAN CAUSE SEVERE PERSONAL INJURY, DEATH OR PROPERTY DAMAGE.

CAUTION**AIR SPRINGS**

INFLATE THE SUSPENSION'S AIR SPRINGS SLOWLY AND MAKE SURE THE RUBBER BLADDER OF THE AIR SPRING INFLATES UNIFORMLY AND IS NOT BINDING. FAILURE TO DO SO CAN CAUSE DAMAGE TO THE AIR SPRING AND / OR MOUNTING BRACKETS AND WILL VOID APPLICABLE WARRANTIES.

WARNING**OFF ROADWAY TOWING**

HENDRICKSON DOES NOT RECOMMEND TOWING A VEHICLE BY THE LIFT AXLE. DOING SO WILL DAMAGE THE AXLE AND WILL VOID APPLICABLE WARRANTIES.

WARNING**PARTS CLEANING**

SOLVENT CLEANERS CAN BE FLAMMABLE, POISONOUS, AND CAUSE BURNS. TO HELP AVOID SERIOUS PERSONAL INJURY, CAREFULLY FOLLOW THE MANUFACTURER'S PRODUCT INSTRUCTIONS AND GUIDELINES AND THE FOLLOWING PROCEDURES:

1. WEAR PROPER EYE PROTECTION.
2. WEAR CLOTHING THAT PROTECTS YOUR SKIN.
3. WORK IN A WELL VENTILATED AREA.
4. DO NOT USE GASOLINE OR SOLVENTS THAT CONTAIN GASOLINE. GASOLINE CAN EXPLODE.
5. HOT SOLUTION TANKS OR ALKALINE SOLUTIONS MUST BE USED CORRECTLY. FOLLOW THE MANUFACTURER'S RECOMMENDED INSTRUCTIONS AND GUIDELINES CAREFULLY TO HELP PREVENT PERSONAL ACCIDENT OR INJURY.

DO NOT USE HOT SOLUTION TANKS OR WATER AND ALKALINE SOLUTIONS TO CLEAN GROUND OR POLISHED PARTS. DOING SO WILL CAUSE DAMAGE TO THE PARTS AND VOID APPLICABLE WARRANTIES.



SECTION 4

SPECIAL TOOLS

The following tools and materials are required when installing and servicing Hendrickson EXF lift axles:

Assembly & Installation:

- Torque wrench (capability of 475 foot-pounds)
- Linear measuring instruments: tape measure, linear scales, machinist square
- Crane or lifting capability
- Hand grinder
- Hammer and center punch
- Drill for mounting holes
- Trammel bar for alignment
- Impact wrench
- Compressed air supply with air fittings, tubing and associated tools
- Socket set and wrenches, including the following sizes: $\frac{9}{16}$ " ; $1-\frac{1}{8}$ " ; $\frac{3}{4}$ " ; $1-\frac{1}{4}$ " deep socket; $1-\frac{7}{16}$ " Impact socket
- C-clamps or bar clamps

Bushing Inspection:

- | | |
|---------------------|--------------------------------|
| ■ Two jack stands | ■ Block of wood |
| ■ Small bottle jack | ■ Magnetic base dial indicator |

Bushing Housing Replacement

- | | |
|--|--------------------------------|
| ■ Hydraulic shop press with a minimum force capacity of 5 tons | ■ Bushing driver |
| | ■ Magnetic base dial indicator |

Integrated Brake Replacement

- Brake spring tool or notched screw driver

Lubrication

- | | |
|--------------------------------|---------------------------|
| ■ Hand or pneumatic grease gun | ■ NLGI-1 or NLGI-2 grease |
|--------------------------------|---------------------------|

Miscellaneous

- Wheel chocks

Documentation (Supplied by Hendrickson in Parts Box)

- Hendrickson Technical Procedure TP-H825 (Assembly & Installation Insert)
- Plumbing schematic

Frame Fasteners, Supplies (Not Supplied by Hendrickson)

- | | |
|---|---|
| ■ 16 SAE Grade-8 bolts, $\frac{3}{4}$ " | ■ 16 IFI $\frac{3}{4}$ " Grade-8 prevailing-torque type steel hex flange nuts |
| ■ 16 hardened flat washers; | ■ 2 Backing plates ($\frac{1}{4}$ " , Grade 50) |
-

SECTION 5 PRE-INSTALLATION TOPICS

The first step to a successful installation is to verify that the lift axle you ordered and received corresponds by type and quantity to your needs and requirements. Contact the Hendrickson Customer Service if any components are missing or damaged or to receive additional information: 800-660-2829 (in US and Canada), 740-929-5600 or liftaxle@hendrickson-intl.com.

LITERATURE:	EVERY HENDRICKSON LIFT AXLE IS SHIPPED WITH A "PARTS BOX" CONTAINING A "LITERATURE PACK" OF TECHNICAL PUBLICATIONS AND LABELS, INCLUDING TP-H825 (AN ASSEMBLY AND INSTALLATION INSERT), WHICH PROVIDES DIMENSIONS FOR CURRENT HENDRICKSON AUXILIARY LIFT AXLE SUSPENSIONS.
IMPORTANT!	REGARDLESS OF THE MODEL AND CONFIGURATION OF YOUR LIFT AXLE, HENDRICKSON RECOMMENDS THAT YOU REVIEW THIS SECTION THOROUGHLY BEFORE BEGINNING ANY INSTALLATION PROCEDURES.
	<ul style="list-style-type: none"> ■ The truck / trailer manufacturer should be consulted before making any changes to the truck / trailer's frame or other components. Typically, cutting or altering the frame or side rail is not permitted and may affect the vehicle manufacturer's warranty coverage. ■ It is the responsibility of the installer to determine the correct location of the suspension in order to provide the proper load distribution. The load carried by each axle must not exceed the rated capacity of the components involved. ■ It is the responsibility of the installer to ensure that proper clearances exist between the following: the drive shaft (driveline) and the lift axle suspension system; tires (laterally, fore / aft, and vertically); air springs and adjacent components (based on the springs' maximum inflated diameter). ■ No welding of any of the lift axle's components is permitted except where specified by Hendrickson. Alteration of lift axle components is not permitted. ■ Prior to any installation, all safety-related information should be read carefully to help prevent personal injury and to assure that proper methods are used. Improper installation may damage the vehicle, render it unsafe in operation, void manufacturer's warranty or cause personal injury.

DRIVELINE CLEARANCE

!IMPORTANT! FOR TRUCK INSTALLATIONS, REFER TO HENDRICKSON TECHNICAL PUBLICATION H854! PRIOR TO INSTALLATION, VERIFY DRIVELINE CLEARANCE BY MEASURING THE DISTANCE FROM THE BOTTOM OF THE TRUCK RAIL TO THE BOTTOM OF THE FULLY ARTICULATED DRIVELINE. IMPROPER MEASUREMENT CAN LEAD TO DAMAGE TO YOUR VEHICLE AND LIFT AXLE!

Figure 5-1 below shows a COMPOSILITE® EXF lift axle. In the lifted position, there must be at least 1-inch of clearance between the vehicle's driveline and the top of the suspension's axle beam.

FIGURE 5-1: DRIVELINE CLEARANCE

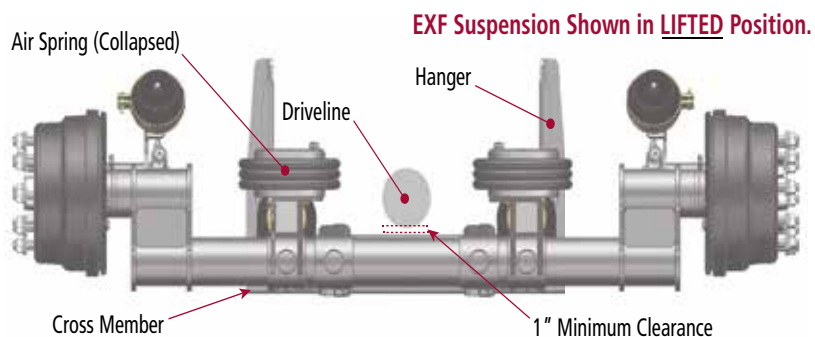

LIFT AXLE LOCATION

In determining the location for an auxiliary lift-axle suspension on a truck or trailer, U.S.-based vehicle owners and / or lift axle installers are responsible for reading and understanding the United States Federal Bridge Formula and Weights Regulation along with their local state laws; it is recommended to work with your state DOT to understand their requirements. Those in other countries and jurisdictions must follow the appropriate local regulations and formulas. General Information: <https://www.hendrickson-intl.com/Bridge-Laws>

Truck or Trailer Lift Axle Applications:

- Verify that the axle spacing conforms to U.S. Federal Bridge Formula and Weights Regulations and all other applicable regulations.
- Verify that the lift axle's location is based on:
 - Vehicle wheel-base
 - Maximum recommended lift axle spacing
- Verify that the vehicle will have the proper load distribution after installation.
- Verify that there is sufficient fore / aft frame rail clearance to mount the lift axle(s).

Additional Considerations (refer to TP-H825):

- Verify that the frame width is within the allowable mounting range of the lift axle.
- Mark the location of the lift axle's side rails on the frame rails. Check for interferences with any existing brackets or mounting bolts.
- Verify that the vehicle / trailer cross members and backing plates are correctly positioned for proper support of the lift axle (Refer to Figure 5-2 below).

IMPORTANT!

DETERMINE THE LOCATION FOR THE LIFT AXLE ACCORDING TO THESE CRITERIA: VEHICLE CROSS MEMBERS MUST BE POSITIONED WITHIN FIVE (5) INCHES FORE OR AFT OF THE SUSPENSION'S FORWARD PIVOT CONNECTIONS AND WITHIN FIVE (5) INCHES FORE OR AFT OF THE CENTER OF THE AIR SPRINGS. MAINTAIN A MINIMUM OF TEN (10) INCHES BETWEEN CROSS MEMBERS.

FIGURE 5-2: CUSTOMER-SUPPLIED CROSS MEMBERS & SPACING

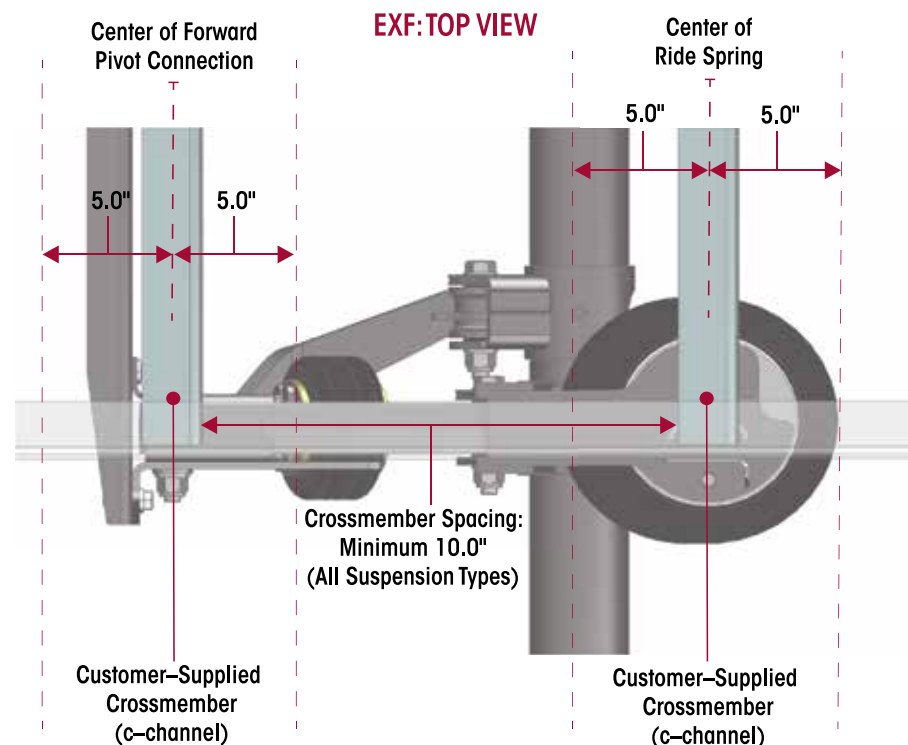

RIDE HEIGHT & FRAME WIDTH

Correct ride height is critical for the safe and efficient operation of your lift axle. For best results, ride height is determined by the distance from the bottom of the vehicle's frame rail to the ground when the vehicle is fully loaded. This ensures the most accurate ride height calculation. However, your measurement might have been calculated based on an unloaded vehicle. In those cases, Hendrickson determines your ride height using a formula to estimate the sag of your specific suspension type.

For a fully loaded vehicle, a correct installation results in the installed suspension's measured ride height being within a tolerance of +/- one inch of the specified ride height.

COMPOSILITE® EXF lift axles are available "factory-ready" with customer-specified ride heights and frame widths for easy, standardized installation for a specific vehicle. COMPOSILITE® EXF "adjustable" suspensions allow the customer to buy lift axles suited for an undetermined vehicle; these adjustable suspensions utilize spacers to accommodate varying vehicle requirements.

If during the installation process you have questions about your suspension's ride height or frame width, please contact Hendrickson Customer Service: 800-660-2829 (TOLL FREE in US and Canada), 740-929-5600 or liftaxle@hendrickson-intl.com.

INSTALLATION NOTE: DO NOT DRILL HOLES IN THE SUSPENSION'S SIDE RAILS (HANGERS), UPPER AIR-SPRING PLATES, OR THE VEHICLE'S FRAME RAIL UNTIL THE RIDE HEIGHT OF YOUR SUSPENSION IS DETERMINE TO BE OPTIMAL!

The COMPOSILITE® EXF adjustable product line can accommodate frame widths of 33.5, 34.0 or 34.5 inches. This suspension option ships with the frame width set to 34.0 inches with two .25" "K" spacers already installed; two additional .25" frame-width "K" spacers are shipped with your suspension in the Hendrickson Parts Box. Twelve ride-height spacers are also included in the Parts Box: 1-inch and 2-inch versions of all three types (See Figures 5-3 and 5-4).

INSTALLATION NOTE: YOUR ADJUSTABLE LIFT AXLE'S FRAME-WIDTH ADJUSTMENT IS ACHIEVED BY REMOVING OR INSERTING THE "K" SPACERS BETWEEN THE SIDE RAILS AND THE BUSHING SADDLES. THE AIR-SPRINGS ("RIDE BAGS") DO NOT REQUIRE FRAME-WIDTH SPACERS OR RE-POSITIONING; THE DESIGN SPECIFICATIONS ALLOW FOR THESE TOLERANCES.

FIGURE 5-3: RIDE HEIGHT & FRAME WIDTH SPACERS

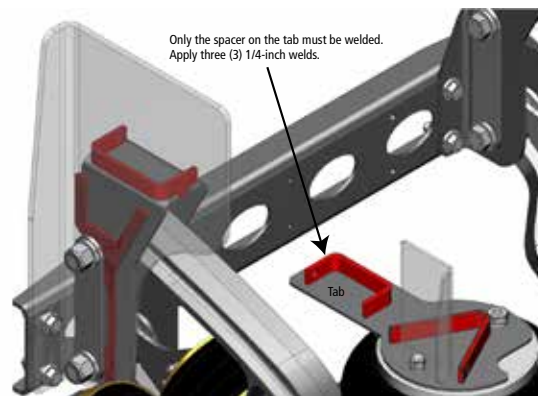
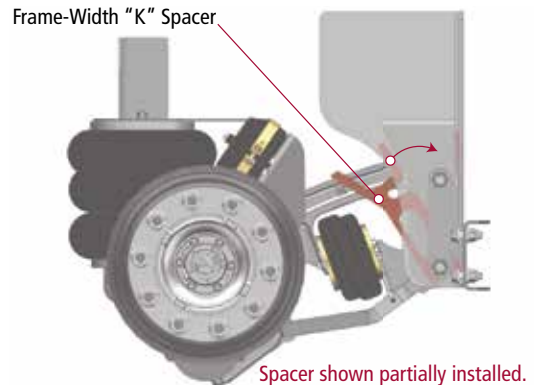

FIGURE 5-4: FRAME WIDTH "K" SPACER



SECTION 6 INSTALLATION

ENGINEERING NOTE: ANY CHANGES TO THE INSTALLATION PROCEDURES INDICATED HEREIN REQUIRE THE WRITTEN PERMISSION OF HENDRICKSON ENGINEERING.

FASTENERS: HENDRICKSON DOES NOT SUPPLY FASTENERS FOR THE INSTALLATION OF YOUR LIFT AXLE TO THE TRUCK RAIL OR TRAILER SUB-FRAME. HENDRICKSON DOES REQUIRE THAT YOU SELECT ¾" 16 SAE GRADE-8 BOLTS, HARDENED FLAT WASHERS, AND IFI* ¾" GRADE-8 PREVAILING-TORQUE TYPE, STEEL HEX FLANGE NUTS. TORQUE SPECIFICATIONS VARY DEPENDING ON THE MANUFACTURER; THEREFORE, THE INSTALLER AND/OR THE OWNER-OPERATOR MUST FOLLOW TORQUE GUIDELINES FOR THE SPECIFIC FASTENERS SELECTED FOR INSTALLATION.

*Industrial Fasteners Institute

TRUCK INSTALLATION

The following instructions cover the installation of Hendrickson COMPOSILITE® EXF lift axles for **Truck Applications**. This section assumes that the correct lift axle was selected based on your individual requirements, including, but not limited to, ride height, frame width, and driveline clearance, and that all other pre-installation issues were thoroughly reviewed during the ordering process or in review of the pre-installation topics outlined in this publication. Once you are sure that you have selected and received the proper suspension, you may proceed with the installation process.

INSTALLATION NOTE: AN AFTERMARKET LIFT AXLE'S MOUNTING SURFACES MUST BE FLUSH WITH THE BOTTOM OF THE TRUCK FRAME RAILS (OR INSTALLED SPACERS). FAILURE TO COMPLY WITH THIS RULE WILL VOID THE SUSPENSION WARRANTY. OEM INSTALLATIONS ARE EXEMPT FROM THIS REQUIREMENT AS CORRECT OEM-SPECIFIC PRE-DRILLED HOLE PATTERNS IN THE SIDE RAIL AND UPPER AIR-SPRING PLATES ASSURE PROPER INSTALLATION POSITION.

CAUTION

BEFORE PROCEEDING, INSPECT THE TRUCK'S FRAME RAILS FOR ANY OBSTRUCTIONS (FUEL LINES, WIRING HARNESSSES, BRAKE LINES, ETC.) THAT MIGHT BE LOCATED ON THE BACK SIDE OF THE TRUCK'S FRAME RAILS. ADJUST ACCORDINGLY BEFORE DRILLING.

1. It is critical that the truck be located on a flat, level surface during the installation process.
2. Set the parking brake and chock the wheels of the truck.
3. Determine the location for the suspension (axle center point) on the truck by following rules stipulated by applicable National / State / Provincial, and / or Local Bridge Formula Weights Regulations.
4. Additionally, determine the location for the suspension on the truck's frame rail according to structural criteria (See Figure 6-1):
 - Vehicle cross members must be positioned within five (5) inches fore or aft of the center of the suspension's forward pivot connections and within five (5) inches fore or aft of the center of the air springs.
 - Maintain a minimum of ten (10) inches between cross members.

FIGURE 6-1: VEHICLE CROSSMEMBERS

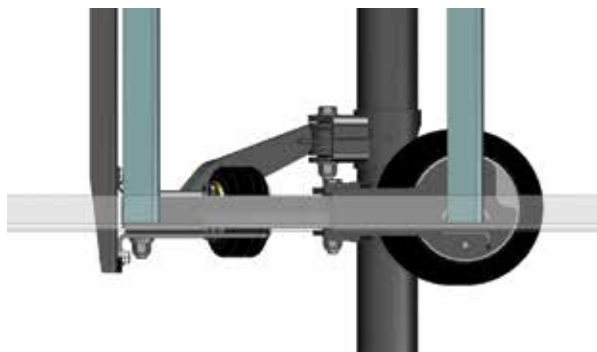

5. Mark the location for the center line of the axle spindle on the outside of the vehicle's frame rails (Remember: this is determined by applicable National / State / Provincial and / or Local Bridge Formula Weights Regulations and the location of the truck's cross members).
6. Mark the locations on one of the truck's frame rails for the lift axle's side rail (hanger) and the upper air spring plate. Verify again that there is no obstruction or interference on the inside of the rail where these mounting locations are marked.

WARNING

FAILURE TO SAFELY RAISE, POSITION AND CLAMP THE LIFT AXLE INTO PLACE CAN RESULT IN DAMAGE TO THE TRUCK AND LIFT AXLE AND CAN LEAD TO PERSONAL INJURY AND DEATH.

7. Raise and position the lift axle into place by using as guides the vehicle's cross members, the marked axle spindle center line, and the marked locations of the lift axle's side rails (hangers) and upper air spring plates.
8. Securely clamp the side rail (hanger) and upper air spring plate with customer-supplied backing plates to the truck's rail (See Figure 6-2).
9. Next, clamp the other side rail (hanger) and upper air-spring plate with customer-supplied backing plates to the truck's other frame rail while verifying that the suspension is in the desired position, is centered on the truck's frame rails, and that the perpendicularity of the lift axle has been verified.

FIGURE 6-2: CUSTOMER-SUPPLIED CROSS MEMBERS & BACKING PLATES

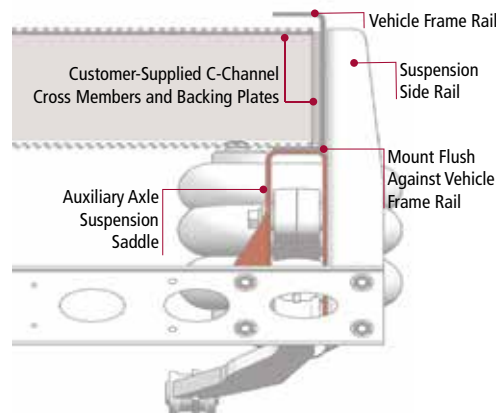

10. Verify again that there are no obstructions on the inside of the truck's frame rails.
11. Next, mark the hole locations on the side rails (hangers) and upper air-spring plates by punch—marking the hole center locations as indicated in Figures 6-3.

TECHNICAL NOTE: FIGURES 6-3 SHOW A SUGGESTED (TYPICAL) BOLT PATTERN; YOUR BOLT PATTERN MAY VARY DUE TO A NUMBER OF STRUCTURAL FACTORS UNIQUE TO YOUR TRUCK'S FRAME RAILS AND OTHER VEHICLE FEATURES.

12. Drill* the first $\frac{13}{16}$ "-diameter hole through the lift axle's side rail (hanger), the vehicle's frame rail, and the customer-supplied backing plate. Inspect the suspension for proper position and install the first $\frac{3}{4}$ " -16 SAE Grade-8 bolt**, one hardened flat washer** and one IFI (Industrial Fasteners Institute) $\frac{3}{4}$ " Grade-8 prevailing-torque type, steel hex flange nut**. "Snug" tighten the hex-flange nut. **Do Not perform final torque yet!**

TECHNICAL NOTE: *DO NOT DRILL OR BOLT THROUGH THE BOTTOM FLANGE OF THE SUSPENSION'S SIDE RAIL (HANGER).

TECHNICAL NOTE: **REFERENCED MOUNTING FASTENER SETS ARE NOT SUPPLIED BY HENDRICKSON.

FIGURES 6-3: SUGGESTED BOLT-HOLE PATTERNS

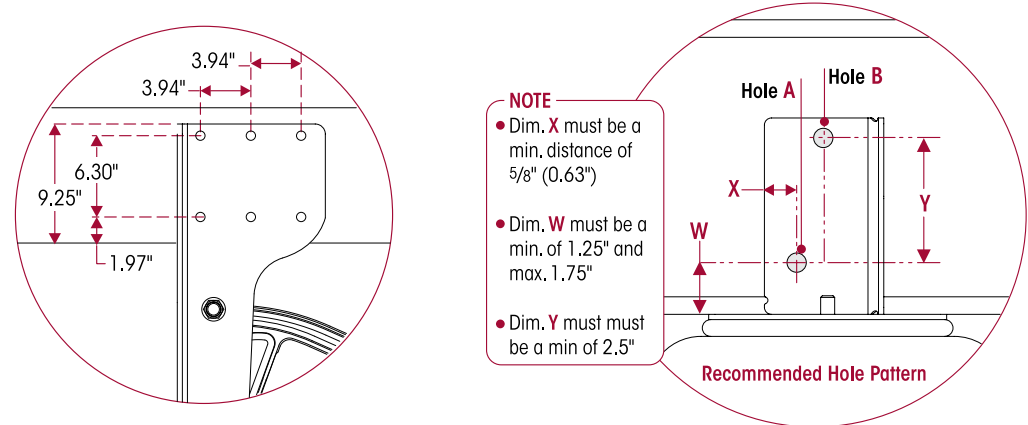

13. Drill the remaining five (5) holes in the side rail (hanger) and two (2) holes in the upper air spring plate and install the seven (7) remaining fastener sets. "Snug" tighten the hex-flange nuts only. Do not perform final torque at this time!
14. Repeat procedures for the other side of the suspension, but DO NOT perform final torque at this time!
15. Verify perpendicularity and parallelism of the lift axle's four mounting points (left and right side rail hangers and left and right upper air spring plates) in relation to the truck's frame rails.
16. Once you are sure of the lift axle's perpendicularity and parallelism, torque all 8 mounting bolts on each side of the lift axle (16 total) according to the fastener manufacturer's specifications (Review the note regarding fasteners on [page 13](#)).

WARNING

FAILURE TO FOLLOW THESE PROCEDURES AND INSTRUCTIONS REGARDING THE INSTALLATION OF HENDRICKSON EXF LIFT AXLES CAN RESULT IN PREMATURE COMPONENT WEAR, LIFT AXLE FAILURE AND LOSS OF WARRANTY COVERAGE.

FINAL ASSEMBLY CHECKLIST

1. Install any remaining miscellaneous hardware.
2. Verify the torque values on all assembly bolts (See [Section 11](#) Torque Specifications).
3. Verify the torque values on all of the lift axle's mounting fasteners (according to fastener supplier's specifications).
4. Install the air controls and plumbing per Hendrickson or other supplier's instructions (Refer to Hendrickson publication OM H817: Air Control Kit Owner's Manual, available online at www.hendrickson-intl.com/Auxiliary).
5. Install wheels and lug nuts; tighten to proper torque (according to fastener supplier's specifications).
6. Ensure there is lubrication in the wheel-end by using the necessary inspection methods. Refer to the Wheel-End Lubrication section in the Technology & Maintenance Council's "Recommended Maintenance Practices Manual" (TMC RP 631).
7. Install the air lines for the lift axle's brakes according to the manufacturer's specifications.
8. Inspect the brakes and adjust if necessary.

NOTE: LIFT AXLES PURCHASED FROM HENDRICKSON SPECIALTY PRODUCTS - AUXILIARY AXLE REQUIRE BRAKE ADJUSTMENT FOR SYSTEMS EQUIPPED WITH AUTOMATIC SLACK ADJUSTERS (REFER TO THE BRAKE MANUFACTURER FOR PROCEDURES).

TRAILER INSTALLATION (BOLT-ON)

ENGINEERING NOTE: ANY CHANGES TO THE INSTALLATION PROCEDURES INDICATED BELOW REQUIRE THE WRITTEN PERMISSION OF HENDRICKSON ENGINEERING.

The following instructions are for the **BOLT-ON** installation of your Hendrickson COMPOSITITE® EXF lift axle for **Trailer Applications**. This section assumes that the correct lift axle was selected based on your individual requirements, including, but not limited to, ride height, frame width, driveline clearance and that all other pre-installation issues were thoroughly reviewed during the ordering process or during the pre-installation process outlined in this publication. Once you are sure that you have selected and received the proper lift axle, you may proceed with the installation process.

FIGURE 6-4: BOLT-ON TRAILER SUSPENSION

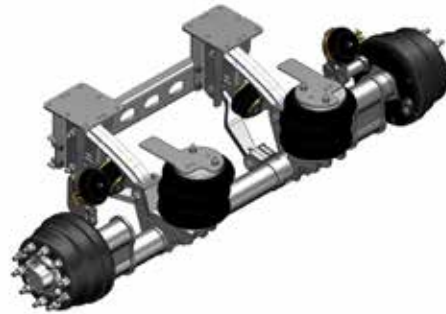
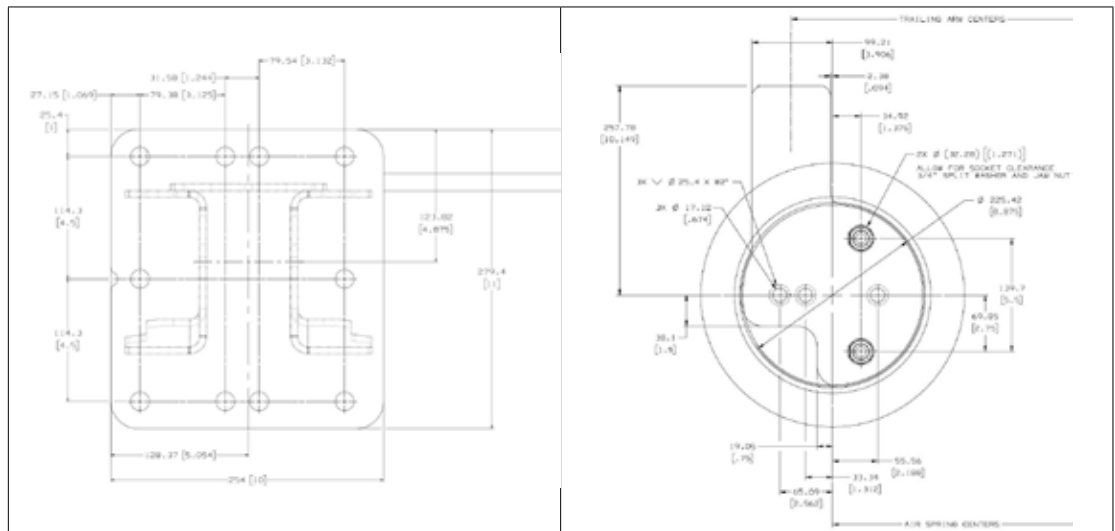

FIGURE 6-5: BOLT-ON TRAILER MOUNTING DETAIL (SEE SECTION 14 FOR LARGER IMAGES)



INSTALLATION NOTE: ON SOME TRAILERS, A SUB-FRAME MAY BE REQUIRED BETWEEN THE LIFT AXLE'S MOUNTING SURFACES AND THE TRAILER'S FRAME TO ACHIEVE THE REQUIRED INSTALLED RIDE HEIGHT. IT IS THE RESPONSIBILITY OF THE LIFT AXLE INSTALLER TO CONSULT WITH THE TRAILER MANUFACTURER TO ENSURE THAT THE TRAILER HAS AN ADEQUATE SUB-FRAME DESIGN AND CROSSMEMBER SUPPORT IN THE MOUNTING AREA FOR THE LIFT AXLE.

INSTALLATION NOTE: THE TRAILER'S RAILS / SUB-FRAME MUST ACCOMMODATE THE BOLT PATTERN OF THE LIFT AXLE'S MOUNTING SURFACES: MOUNTING PADS AND UPPER AIR-SPRING PLATES (SEE FIGURE 6-5).



CAUTION INSPECT TRAILER FRAME AND CROSS MEMBERS FOR ANY OBSTRUCTION (WIRING HARNESSSES, BRAKE LINES, ETC.) THAT MIGHT INTERFERE WITH THE INSTALLATION PROCESS. ADJUST ACCORDINGLY BEFORE INSTALLATION.



1. It is critical that the trailer be located on a flat, level surface during the installation process.
2. Chock the wheels of the trailer.
3. Determine the location for the lift axle (axle spindle center point) on the trailer by following rules stipulated by applicable National / State / Provincial and / or Local Bridge Formula Weights Regulations.
4. Additionally, determine the location for the lift axle on the trailer's frame rail according to these structural criteria:
 - Trailer cross members must be positioned within five (5) inches fore or aft of the center of the suspension's forward pivot connections and within five (5) inches fore or aft of the center of the air springs.
 - Maintain a minimum of ten (10) inches between cross members.
5. Mark the location of the center line of the axle on the outside of the trailer's frame rail.
6. Refer to Hendrickson Publication [TP-H825](#) for lift axle dimensions to assist with determining the boundary locations of the mounting surfaces.
7. Allowances should be made at this time for correcting any interferences that may occur between the lift axle's mounting surfaces and any existing bolts or brackets (located in the marked boundary areas) on the trailer's frame rails or sub-frame.

WARNING

FAILURE TO SAFELY RAISE, POSITION, AND CLAMP THE LIFT AXLE INTO PLACE CAN RESULT IN DAMAGE TO THE TRAILER AND LIFT AXLE AND CAN LEAD TO PERSONAL INJURY AND DEATH.

8. Raise and position the lift axle into place by using the trailer's cross members, the marked axle center line and the marked boundary areas as locators.
9. Verify that the lift axle is centered side-to-side on the trailer's rails / sub-frame! This is a critical difference between trailer and truck application installation procedures. Whereas the truck's rails serve as a default centering guide, lift axles on trailers must be centered on the rails / sub-frame without this built-in "guide". You must verify as well that the lift axle is parallel and perpendicular to the trailer's rails and/or sub-frame.
10. Clamp the lift axle's mounting surfaces to the trailer's rails and / or sub-frame.
11. Mark the locations for the centers of the mounting bolt holes.
12. Verify accuracy of the hole locations and then punch-mark the centers for the holes.
13. Drill the first 13/16" diameter hole through the auxiliary suspension's mounting plate and the trailer's frame rail. Inspect the suspension for proper position and install the first 3/4" 16 SAE Grade-8 bolt*, one hardened, flat washer* and one IFI (Industrial Fasteners Institute) 3/4" Grade-8 prevailing-torque type steel hex-flange nut*. "Snug" tighten the hex-flange nut. Do not perform final torque at this time!

NOTE:

*THESE REQUIRED MOUNTING FASTENERS ARE NOT SUPPLIED BY HENDRICKSON.

14. Drill the remaining holes and install the remaining fastener sets. "Snug" tighten the hex flange nuts. Do not perform final torque at this time!
15. Inspect the opposite side of the suspension for perpendicularity and parallelism between the trailer's frame rail and the suspension. Repeat steps for the opposite side of the suspension.
16. Once you are sure of the suspension's perpendicularity and parallelism between the trailer's frame rail and the suspension, torque all mounting bolts on both sides of the suspension according to the fastener manufacturer's specifications.

FINAL ASSEMBLY CHECKLIST

1. Install any remaining miscellaneous hardware.
2. Verify the torque values on all suspension mounting bolts and assembly bolts (Refer to [Section 11 Torque Specifications](#) of this publication).
3. Install the air controls and plumbing per Hendrickson or other supplier's instructions (Refer to Hendrickson publication [OM H817: Air Control Kit Owner's Manual](#), available online at www.hendrickson-intl.com).

4. Install wheels and lug nuts, tighten to proper torque. Refer to [Section 11 Torque Specification](#) of this publication.
5. Ensure there is lubrication in the wheel end by using the necessary inspection methods. Refer to the Wheel-End Lubrication section in the Technology & Maintenance Council's "Recommended Maintenance Practices Manual" (TMC RP 631).
6. Inspect the brakes and adjust if necessary.

NOTE: SUSPENSIONS PURCHASED FROM HENDRICKSON SPECIALTY PRODUCTS - AUXILIARY AXLE REQUIRE BRAKE ADJUSTMENT FOR SYSTEMS EQUIPPED WITH AUTOMATIC SLACK ADJUSTERS (REFER TO THE BRAKE MANUFACTURER FOR PROCEDURES).

TRAILER INSTALLATION (WELD-ON)

ENGINEERING NOTE: ANY CHANGES TO THE INSTALLATION PROCEDURES INDICATED BELOW REQUIRE THE WRITTEN PERMISSION OF HENDRICKSON ENGINEERING.

The following instructions are for the WELD-ON installation of your Hendrickson COMPOSITE® EXF lift axle for Trailer Applications. This section assumes that the correct auxiliary axle suspension system was selected based on your individual requirements, including, but not limited to, ride height, frame width, and driveline clearance, and that all other pre-installation issues were thoroughly reviewed during the ordering process or during the pre-installation process outlined in this publication. Once you are sure that you have selected and received the proper suspension, you may proceed with the installation process.

FIGURE 6-6: WELD-ON TRAILER SUSPENSION

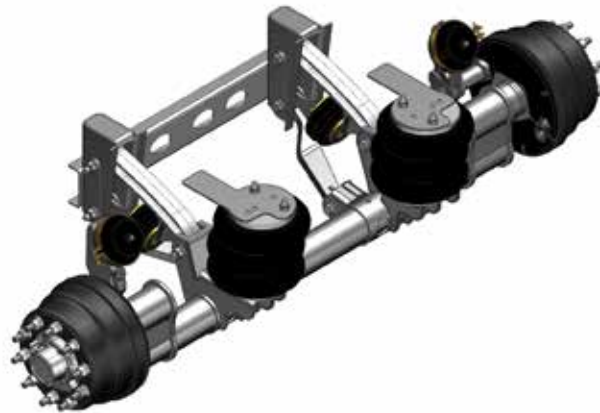
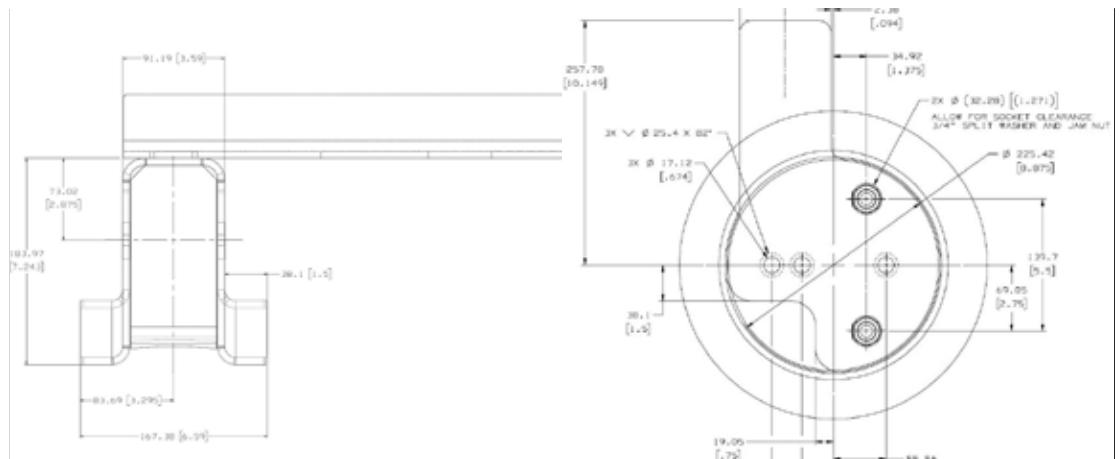

FIGURE 6-7: WELD-ON TRAILER MOUNTING DETAIL (SEE SECTION 14 FOR LARGER IMAGES)



INSTALLATION NOTE: ON SOME TRAILERS, A SUB-FRAME MAY BE REQUIRED BETWEEN THE LIFT AXLE'S MOUNTING SURFACES AND THE TRAILER'S FRAME TO ACHIEVE THE REQUIRED INSTALLED RIDE HEIGHT. IT IS THE RESPONSIBILITY OF THE LIFT AXLE INSTALLER TO CONSULT WITH THE TRAILER MANUFACTURER TO ENSURE THAT THE TRAILER HAS AN ADEQUATE SUB-FRAME DESIGN AND CROSSMEMBER SUPPORT IN THE MOUNTING AREA FOR THE LIFT AXLE.

INSTALLATION NOTE: THE TRAILER'S RAILS/SUB-FRAME MUST ACCOMMODATE THE LIFT AXLE'S WELD-ON MOUNTING SURFACES: MOUNTING PADS AND UPPER AIR-SPRING PLATES (SEE FIGURE 6-7).

CAUTION

INSPECT TRAILER FRAME AND CROSS MEMBERS FOR ANY OBSTRUCTION (WIRING HARNESSSES, BRAKE LINES, ETC.) THAT MIGHT INTERFERE WITH THE WELDING/INSTALLATION PROCEDURES. ADJUST ACCORDINGLY BEFORE BEGINNING THESE PROCEDURES.

1. It is critical that the trailer be located on a flat, level surface during the installation process.
2. Chock the wheels of the trailer.
3. Determine the location for the suspension (axle center point) on the trailer by following rules stipulated by applicable National / State / Provincial and / or Local Bridge Formula Weights Regulations.
4. Additionally, determine the location for the lift axle on the trailer's frame rails/sub-frame according to these structural criteria:
 - Trailer cross members must be positioned within five (5) inches fore or aft of the center of the lift axle's forward pivot connections and within five (5) inches fore or aft of the center of the air springs.
 - Maintain a minimum of ten (10) inches between cross members.
5. Mark the location of the center line of the axle spindle on the outside of the trailer's frame rail.
6. Refer to Hendrickson Technical Publication TP-H825 for lift axle dimensions to assist with determining the boundary locations of the mounting surfaces.
7. Allowances should be made at this time for correcting any interferences that may occur between the lift axle's mounting surfaces and any existing bolts or brackets.

WARNING

FAILURE TO SAFELY RAISE, POSITION, AND CLAMP THE LIFT AXLE INTO PLACE CAN RESULT IN DAMAGE TO THE TRAILER AND LIFT AXLE AND CAN LEAD TO PERSONAL INJURY AND DEATH.

8. Raise and position the auxiliary lift axle suspension into place by using the trailer's cross-members, the marked axle center line and the marked boundary areas as locators.
9. Verify that the suspension is centered on the trailer's frame.
10. Clamp the suspension's mounting surfaces to the trailer's rails / sub-frame.
11. Mark the locations for mounting surfaces.
12. Inspect the opposite side of the suspension for perpendicularity and parallelism between the trailer's frame rail / sub-frame and the suspension. Repeat steps for the opposite side of the suspension.
13. Once you are sure of the suspension's proper position, its perpendicularity and parallelism, weld the suspension's weld mounts to the frame / sub-frame.

FINAL ASSEMBLY CHECKLIST

1. Install any remaining miscellaneous hardware.
2. Verify the torque values on all suspension mounting bolts and assembly bolts (Refer to [Section 11 Torque Specifications](#)).
3. Install the air controls and plumbing per Hendrickson or other supplier's instructions (Refer to Hendrickson publication [OM H817: Air Control Kit Owner's Manual](#), available online at www.hendrickson-intl.com).
4. Install wheels and lug nuts, tighten to proper torque (Refer to the [Section 11 Torque Specifications](#)).

5. Ensure there is lubrication in the wheel end by using the necessary inspection methods. Refer to the Technology & Maintenance Council's Wheel-End Lubrication section in the "Recommended Maintenance Practices Manual" (TMC RP 631).
6. Install the air lines for the lift axle's brakes according to the brake manufacturer's specifications and instructions. Contact Hendrickson Customer Service with any questions.
7. Inspect the brakes and adjust as needed.

NOTE: SUSPENSIONS PURCHASED FROM HENDRICKSON SPECIALTY PRODUCTS - AUXILIARY AXLE REQUIRE BRAKE ADJUSTMENT FOR SYSTEMS EQUIPPED WITH AUTOMATIC SLACK ADJUSTERS (REFER TO THE BRAKE MANUFACTURER FOR PROCEDURES).

SECTION 7 LIFT AXLE ALIGNMENT

Proper alignment of the lift axle depends significantly on its initial proper installation on the vehicle or trailer frame. However, the COMPOSILITE® EXF system allows for a certain degree of post-installation fore and aft adjustment.

NOTE: PRE-ALIGNMENT REQUIREMENTS: SINCE THE LIFT AXLE (IN THE "TAG" OR "PUSHER" POSITION) WILL BE ALIGNED RELATIVE TO THE TRUCK'S DRIVE AXLE (OR TO A TRAILER'S PRIMARY AXLE), IT IS ESSENTIAL THAT THE DRIVE OR PRIMARY AXLE BE PROPERLY ALIGNED AND SQUARED TO THE TRUCK / TRAILER CENTER LINE PRIOR TO INSTALLATION OF THE LIFT AXLE.

The COMPOSILITE® EXF alignment system includes alignment plates and two slots provided on each of the suspension's side rails, which permit fore and aft movement at the connection (See Figures 7-1 and 7-2). Once proper alignment has been achieved and the side rail bolts have been torqued, the alignment collars should be stitch welded to the side rails to maintain alignment during maintenance procedures requiring disassembly, for example, pivot bushing replacement (See Figure 7-3).

ALIGNMENT COMPONENTS & LOCATIONS:

FIGURE 7-1

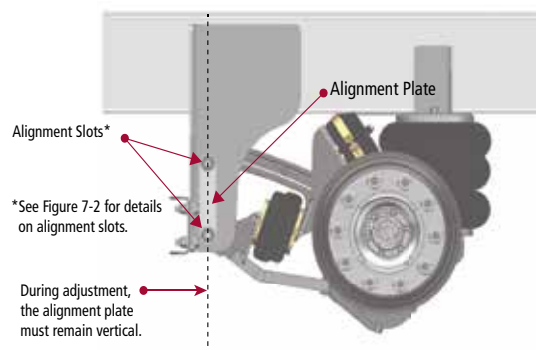
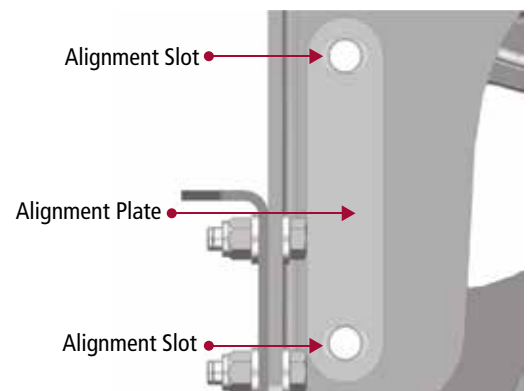

FIGURE 7-2



Please read all of the following steps before proceeding with the alignment adjustment procedure

⚠ DANGER

IT IS IMPORTANT THAT YOU PURGE ALL AIR FROM THE SYSTEM TO COMPLETE THESE PROCEDURES; DE-PRESSURIZE THE ENTIRE SYSTEM, MAKING SURE NO CHECK VALVES HAVE BEEN OVERLOOKED.

1. Secure the vehicle, chock the wheels, and release the brakes on the lift axle. This will allow for tire rotation (roll) while positioning the suspension fore and aft in later steps.

2. As noted above, de-pressurize the entire air system.
3. Once de-pressurized, the suspension should lower to the ground; if not, check for any physical obstructions on the suspension or for obstructions within the air system (hoses, valves, connections).
4. Inspect the vehicle / trailer tire set. Tires must be matched to a maximum of $\frac{1}{8}$ " variation in tire radius and a maximum of $\frac{3}{4}$ " variation in tire circumference.
5. Loosen, but do not disassemble, the four pivot bolts that connect both trailing arms.
6. Position one pair of trailing arms so that the alignment collar's holes and the trailing arms' holes are in the center of the side-rail's alignment slots (you will have to loosen the nuts sufficiently so that you can see behind the bolt heads). Once in position, "snug" tighten the pivot bolts on this side only. Do not perform final torque yet! Please note that in [Figure 7-2](#) above, the elongated alignment slots are in the side rail (hanger) not in the alignment plate; the illustrated depiction can be misinterpreted.
7. Next, position fore or aft the other set of loose trailing arms until the axle beam is equidistant to the center of the vehicle's primary axle spindle on both sides. It is recommended to use a trammel bar. Next, "snug" tighten the bolts. A maximum of $\frac{1}{16}$ " tolerance is commonly considered acceptable.
8. Re-check alignment and then torque all four pivot bolts according to the torque specifications in [Section 11](#) of this publication.
9. RECOMMENDED: At this point, you should stitch-weld the alignment plates to the side rails to maintain alignment during maintenance procedures requiring disassembly, for example, during bushing replacement. See [Figure 7-3](#) below.

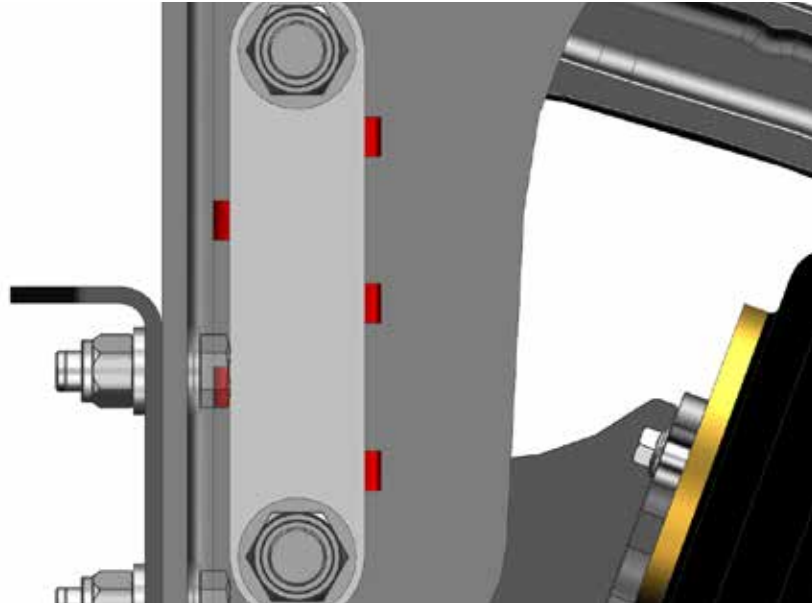
FIGURE 7-3: STITCH-WELD LOCATIONS

NOTE: THE ALIGNMENT SHOULD BE WITHIN $\pm 1/16$ OF AN INCH TO BE CONSIDERED ACCEPTABLE.

CAUTION

ALWAYS WEAR EYE PROTECTION WHEN OPERATING PNEUMATIC TOOLING.

SECTION 8 LIFT AXLE OPERATION

INSIDE/OUTSIDE-MOUNTED AIR CONTROL KITS

1. If vehicle is already running, please proceed to the appropriate section below.
2. Set the vehicle's parking brake.
3. Turn vehicle's ignition to **ON** position.
4. Press ignition **START** switch and release when engine is started.
5. Allow the vehicle to idle until the vehicle's air system pressure has reached the compressor cut out point (typically 120 psi).

RAISING THE LIFT AXLE

1. Where are the lift axle controls mounted?
 - **Inside the vehicle cab:** move the control panel mechanism (pull to lift) to the **UP** position.
 - **Outside the vehicle cab:** ensure vehicle is stopped and parking brake is set. Exit vehicle, go to and open air control enclosure. Move the control panel mechanism to the **UP** position.
2. Visually confirm that the lift axle is lifting.

NOTE: AIR SYSTEM PRESSURE MAY DROP DURING SUSPENSION LIFTING PROCESS.

- Lift axle should be completely lifted when air system pressure returns to the air compressor cut out point (typically 120 psi).

LOWERING THE LIFT AXLE

CAUTION

DO NOT LOWER LIFT AXLE WHILE VEHICLE IS MOVING IN REVERSE OR TRAVELLING MORE THAN 15 MPH. FAILURE TO DO SO CAN CAUSE COMPONENT DAMAGE.

- Where are the lift axle controls mounted?
 - Inside** the vehicle cab: move the control panel mechanism (push to lower) to the "axle down" position.
 - Outside** the vehicle cab: ensure the vehicle is stopped and parking brake is set. Exit vehicle, go to and open air control enclosure. Move the control panel mechanism to the "axle down" position.
- Using the regulator, adjust air system pressure on the gauge to appropriate air pressure for vehicle load conditions.

NOTE: AIR SYSTEM PRESSURE MAY DROP DURING SUSPENSION LOWERING PROCESS.

- Lift axle should be completely lowered and support pre-determined load when air system pressure returns to the air compressor cut-out point (typically 120 psi).

NAVIGATING A 90-DEGREE CURVE OR TURN

CAUTION

TO MINIMIZE PREMATURE TIRE WEAR OR POSSIBLE DAMAGE TO LIFT AXLE COMPONENTS, THE LIFT AXLE MAY BE RAISED TO THE UP POSITION PRIOR TO NAVIGATING A 90-DEGREE OR TIGHTER CURVE OR TURN. COMPLY WITH ALL NATIONAL / STATE / PROVINCIAL AND / OR LOCAL WEIGHT, DIMENSION AND CONFIGURATION REGULATIONS UNDER LOADED AND UNLOADED CONDITIONS.

SECTION 9

AIR PRESSURE LOADS

The air pressure load chart(s) on the following pages are intended to assist vehicle owners, operators and fleet managers (i) to estimate the lift axle air system pressure necessary to support a particular target lift axle load and (ii) to meet applicable National / State / Provincial and / or local vehicle weight regulations.

The air pressure load chart(s) list estimated lift axle air system pressure requirements:

- Ride air spring extension measurements (refer to [Figure 9-1](#));
- Axle lift measurements (refer to [Figure 9-1](#)); and
- Target lift axle loads.

The estimated lift axle air system pressure requirements listed in the air pressure load chart(s) are applicable to a range of lift axle ride heights and tire sizes intended for Hendrickson non-steerable lift axle applications. The actual lift axle air system pressure needed to support a particular target lift axle load may vary depending upon the above-referenced parameters, as well as vehicle and lift axle configuration, operation, payload, service and other factors. If necessary, vehicle operators should use appropriate truck/trailer weight scale equipment to measure actual lift axle loads.

NOTE: ANY / ALL PENALTIES INCURRED FROM IMPROPERLY LOADED VEHICLES OR IMPROPERLY INSTALLED, MODIFIED, OPERATED, SERVICED OR MAINTAINED LIFT AXLE SYSTEMS ARE THE SOLE RESPONSIBILITY OF THE VEHICLE OWNER, OPERATOR, AND / OR FLEET MANAGER. HENDRICKSON AUXILIARY AXLE SYSTEMS SHALL NOT BE RESPONSIBLE FOR ANY SUCH PENALTIES OR ANY DAMAGE OR OTHER ADVERSE EFFECTS ON VEHICLE AND / OR LIFT AXLE FORM, FIT OR FUNCTION DUE TO ANY SUCH IMPROPER ACTIVITY.

NOTE:

IT IS THE RESPONSIBILITY OF THE VEHICLE OWNER-OPERATOR AND / OR FLEET MANAGER TO ENSURE THE VEHICLE AND LIFT AXLE(S) COMPLY WITH ALL APPLICABLE NATIONAL / STATE / PROVINCIAL AND / OR LOCAL WEIGHT, DIMENSION AND CONFIGURATION REGULATIONS UNDER LOADED AND UNLOADED CONDITIONS. CONSULT YOUR APPROPRIATE REGULATORY AND / OR LAW ENFORCEMENT AUTHORITIES TO DETERMINE HOW SUCH REGULATIONS MAY (I) VARY BY OPERATING LOCATION, AND (II) APPLY TO YOUR PARTICULAR VEHICLE, LIFT AXLE(S) AND APPLICATIONS.

WARNING

PRIOR TO AND DURING DEFLATION AND INFLATION OF THE AIR SUSPENSION SYSTEM, ENSURE THAT ALL PERSONNEL AND EQUIPMENT ARE CLEAR FROM UNDER THE VEHICLE AND AROUND THE SERVICE AREA, FAILURE TO DO SO CAN CAUSE SERIOUS PERSONAL INJURY, DEATH OR PROPERTY DAMAGE.

FIGURE 9-1

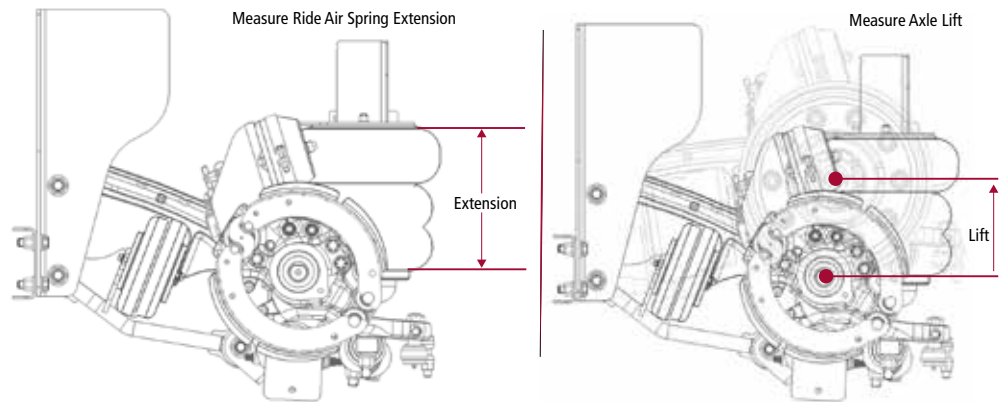

COMPOSILITE EXF 13.5K										
RIDE AIR SPRING EXTENSION (in inches)	10.5"	11.0"	11.5"	12.0"	12.5"	13.0"	13.5"	14.0"	14.5"	
AXLE LIFT (in inches)	6.0"	6.5"	7.0"	7.5"	8.0"	8.5"	9.0"	9.5"	10.0"	



AXLE LOAD (in pounds)	5,000	30	31	32	33	35	36	38	40	43	ESTIMATED AIR SYSTEM PRESSURE REQUIREMENTS (in PSI)
	5,500	34	35	36	37	39	41	43	45	48	
	6,000	37	39	40	41	43	45	47	50	53	
	6,500	41	42	44	45	47	49	52	54	58	
	7,000	45	46	48	49	51	54	56	59	63	
	7,500	48	50	51	53	55	58	61	64	67	
	8,000	52	53	55	57	59	62	65	68	72	
	8,500	55	57	59	61	64	66	69	73	77	
	9,000	59	61	63	65	68	70	74	77	82	
	9,500	63	65	67	69	72	74	78	82	86	
	10,000	66	68	70	73	76	79	82	86	91	
	10,500	70	72	74	77	80	83	86	91	95	
	11,000	73	76	78	81	84	87	91	95	100	
	11,500	77	79	82	84	88	91	95	99	104	
	12,000	80	83	85	88	91	95	99	104	108	
	12,500	84	86	89	92	95	99	103	108	113	
	13,000	88	90	93	96	99	103	107	112	117	
13,500	91	94	97	100	103	107	111	116	121		



SECTION 10 PREVENTIVE MAINTENANCE

DAILY / PRE-TRIP OPERATOR INSPECTION

Daily (and before each trip) inspect all lift axle components for proper operating condition and proper installation to the truck / trailer frame. This essential **Daily / Pre-Trip Operator Inspection** must also include a visual inspection of all wheel seals and gaskets for leaks, a verification of proper oil level in the hubs (if applicable), inspection of all lift and ride air springs for wear, and inspection of all tires for proper inflation and abnormal wear patterns. Identify and repair / replace any loose, damaged or improperly installed components.

NOTE:

REPLACE ANY SAFETY DECALS THAT ARE FADED, TORN, MISSING, ILLEGIBLE OR OTHERWISE DAMAGED. CONTACT HENDRICKSON TO ORDER REPLACEMENT LABELS.

GENERAL INSPECTION

Following appropriate inspection procedures is important to help ensure the proper maintenance and operation of the lift axle and that component parts function to their highest efficiency.

- **Fasteners:** inspect for any loose or damaged fasteners on the entire lift axle. Make sure all fasteners are tightened to the specified torque. Refer to the [Torque Specifications Section](#) of this publication if fasteners are supplied by Hendrickson. For non-Hendrickson fasteners, refer to the vehicle manufacturer. Use a calibrated torque wrench to check torque in a tightening direction. As soon as the fastener starts to move, record the torque. Correct the torque if necessary. Replace any worn or damaged fasteners.
- **Air springs:** visually inspect lift axle for any debris rubbing against air springs or signs of chaffing. Clear debris and / or replace air springs with Hendrickson Genuine Parts as needed.

It is important to conduct appropriate inspection procedures regularly to help ensure the proper operation and service life of the lift axle and its components. Hendrickson recommends that your **COMPOSILITE® EXF** lift axle be inspected upon receipt (pre-installation), at the first in-service inspection interval, and at regular preventive maintenance intervals thereafter. Inspection must include the following items and other components referenced in this section.

HENDRICKSON-RECOMMENDED MAINTENANCE INTERVALS

COMPONENT	INITIAL	INTERVALS AFTER INITIAL BREAK-IN	PROCEDURE
Wheel Bearings	5,000 mi.	Every 8,000 miles or every 2 months, whichever comes first.	Verify end play is between 0.001" and 0.005". Adjust as required and add grease or oil.
Brake Chamber & Components	3,000 mi.	Every 20,000 miles or 10 months, whichever comes first.	Inspect for leaks and inspect brake chamber components for wear.
Wheel Seals	5,000 mi.	Every 5,000 miles or every 2 months, whichever comes first.	Inspect seals for leaks. NOTE: If the hubs or drums are removed for service, wheel seals will require replacement.
Pivot Connections	5,000 mi.	Every 5,000 miles or as needed, whichever comes first.	Verify torque

HENDRICKSON-RECOMMENDED LUBRICATION SPECIFICATIONS

COMPONENT	GREASE
Wheel Bearings	NLGI-1 or NLGI-2 grease; GL-5 gear lubricant

WARNING

FAILURE TO LUBRICATE THE WHEEL BEARINGS CAN RESULT IN COMPONENT DAMAGE, BODILY INJURY OR DEATH.

COMPONENT INSPECTION

- Air Springs: Look for chaffing or any signs of spring or component damage.
- Fasteners: Look for any loose or damaged fasteners on the entire lift axle assembly. Ensure all fasteners are tightened to the specified torque. Use a calibrated torque wrench to check torque in a tightening direction. As soon as the fastener starts to move, record the torque. Correct the torque if necessary. Replace any worn or damaged fasteners.
- Tire wear: Inspect tires for wear patterns that may indicate suspension damage or misalignment. (See Figures 9-1 to 9-6).
- Wear and damage: Inspect all parts of the suspension system for wear and damage. Look for bent or cracked parts. Replace all worn or damaged parts.
- See vehicle manufacturer's applicable publications for other preventive maintenance requirements.

NOTE:

DEFECTIVE COMPONENTS ARE TO BE RETURNED TO THE HENDRICKSON CUSTOMER SERVICE DEPARTMENT IN EXCHANGE FOR REPLACEMENT COMPONENTS, PROVIDED PRODUCT WARRANTY CONDITIONS ARE MET.

TIRE INSPECTION

The leading potential causes of tire wear on commercial vehicles according to the Technology & Maintenance Council (TMC) are the following in order of importance:

1. Tire Pressure
2. Toe Setting (not applicable to non-steerable suspensions)
3. Thrust Angle
4. Camber (not applicable to non-steerable suspensions*)

*Camber on a Hendrickson non-steerable suspension is set at the factory and is not a factor unless the suspension as a whole or the axle individually has been damaged (bent) while in service.

The following tire inspection guidelines are based upon Technology & Maintenance Council's (TMC) recommended practices. Any issues regarding irregular tire wear for which Hendrickson is asked for assistance will require tire and alignment maintenance records as described in the TMC Literature No. RP 642 (Guidelines for Total Vehicle Alignment). Tire wear is normally the best indicator of vehicle alignment conditions. If tires are wearing too rapidly or irregularly, alignment corrections may be needed. The tire wear patterns described below can help to pinpoint specific alignment problems. The most common conditions of concern are the following:

OVERALL FAST WEAR (Miles per 32nd)

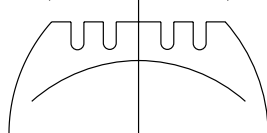

FIGURE 9-1: OVERALL FAST WEAR Fast wear can be described as exhibiting a normal wear pattern but with wear occurring at an accelerated rate. It is typically caused by operating conditions: mountainous terrain, frequency and severity of turning, abrasive road surfaces in combination with vehicle configurations and their attributes, such as power steering, heavy axle loads, high wheel cuts, setback axles, short wheelbase tractors, and long wheelbase straight trucks. To correct this problem, consult with vehicle and tire manufacturers when specifying equipment or replacing tires. For more information, see TMC Literature No. RP 219 ("Radial Tire Wear Conditions and Causes"). For information on how to accurately measure and record tire rates, see TMC Literature No. RP 230 ("Tire Test Procedures for Tread Wear, Serviceability and Fuel Economy").

FEATHER WEAR

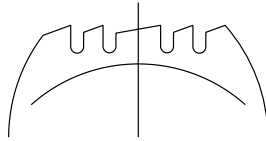

FIGURE 9-2: FEATHER WEAR Tread ribs or blocks worn so that one side is higher than the other resulting in step-offs across the tread face. Generally, ribs or blocks exhibit this wear. To spot this problem, do the following:

With one hand flat on the tread of the tire and a firm down-pressure, slide your hand across the tread of the tire. In one direction, the tire will feel smooth and in the opposite direction there will be a sharp edge to the tread. Typical causes of feather wear include excessive side force scrubbing, resulting from conditions of misalignment such as excessive toe; drive axle misalignment; worn, missing or damaged suspension components; bent tie rods; or other chassis misalignment.

To correct this problem, tires can be rotated to another axle for maximum utilization of remaining tread. Additionally, diagnose the vehicle itself and correct misalignment condition as required. If steer tire feathers are in opposite directions, an improper toe condition is most likely the cause. For more information, see TMC Literature No. RP 219 ("Radial Tire Wear Conditions and Causes", page 5.)

If feather wear on both steer tires is in the same direction, drive axle or other chassis misalignment is indicated. If one steer tire shows feather wear and the other steer tire has normal wear, a combination of toe and drive axle or chassis misalignment is indicated.

CUPPING

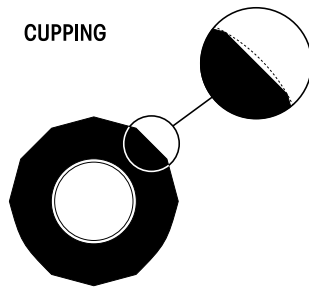

FIGURE 9-3: CUPPING Localized, dished-out areas of fast wear creating a scalloped appearance around the tire. Cupping, which appears around the tire on the shoulder ribs, may also progress to adjoining ribs. See TMC Literature No. RP 219 ("Radial Tire Wear Conditions and Causes"), page 7. Cupping is usually a result of moderate-to-severe imbalance, improper rim / wheel mounting, excessive wheel-end-play or other assembly non-uniformity. It can also be due to lack of stabilizer control on some suspension types. To solve cupping problems:

- Tires: correct mis-mount or balance problem. If ride complaints arise, steer tires may be rotated to drive or trailer axle
- Vehicle: diagnose component imbalance condition, i.e., wheel, rim, hub, brake, drum. Correct as necessary.

DIAGONAL WEAR

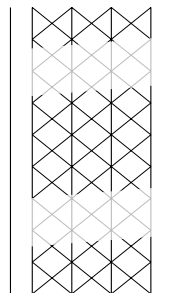

FIGURE 9-4: DIAGONAL WEAR Can be described as localized flat spots worn diagonally across the tread at approximately 25-35 degree angles, often repeating around the tread circumference. For more information, see TMC Literature No. RP 219 ("Radial Tire Wear Conditions and Causes", page 20).

Diagonal wear is usually caused by bad wheel bearings, toe-out, mis-mounting of tire and wheel assembly to axle, and mismatched duals for size and / or inflation pressures. It may start as brake skid. Diagonal wear is aggravated by high speed empty or light load hauls.

To correct diagonal wear, reverse direction of rotation of the tire. If wear is excessive, true or retread. If the source of trouble is the vehicle, diagnose cause and correct as needed.

RAPID SHOULDER WEAR (One Shoulder Only)

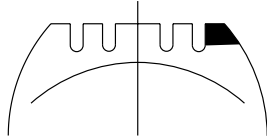

FIGURE 9-5: RAPID SHOULDER WEAR (One Shoulder Only) Is defined as a tire worn on the edge of one shoulder, sometimes extending to inner ribs. It can progress to diagonal wipeout. For more information, see TMC Literature No. RP 219 ("Radial Tire Wear Conditions and Causes", page 22).

This wear condition is usually caused by excessive toe or excessive camber. These conditions can be created by a misaligned or bent axle and can also be caused by loose or worn wheel bearings.

To correct this type of rapid shoulder wear:

- Tires: change direction of rotation of tire. If shoulder wear is severe, remove and retread
- Vehicle: diagnose misalignment and / or mechanical condition and correct

ONE-SIDED WEAR

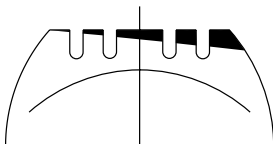

FIGURE 9-6: ONE-SIDED WEAR Excessive wear on one side of tire extending from the shoulder towards the center of the tread. For more information, see TMC Literature No. RP 219 ("Radial Tire Wear Conditions and Causes", page 26) .

One-sided wear is usually caused by improper alignment, worn kingpins, loose wheel bearings, excessive camber, excessive axle loads, non-parallel axles or non-uniform tire and wheel assembly caused by improper bead seating or bent wheel. To correct one-sided wear:

- Tires: Depending on severity, rotate tires to another axle position or, if worn to minimum tread depths, submit for possible retreading.
- Vehicle: Diagnose mechanical problem and correct.



SECTION 11

TORQUE SPECIFICATIONS

HENDRICKSON-RECOMMENDED TORQUE SPECIFICATIONS (ORDERED BY SIZE OF FASTENER)

NO.	DESCRIPTION	SIZE	TORQUE VALUE (FOOT-POUNDS)	
1.	Air Spring Bolt (Lower)	3/8"	25-30	
2.	Air Spring Nut (Upper)	1/2"	45-50	
3.	Air Spring Bolt (Lower)	1/2"	25-30	
4.	Air Spring Nut (Upper)	3/4"	45-50	
5.	Brake Bolts	9/16"	90-110	
6.	Bolt-on Brake Attachments	5/8"	160-180	
7.	Suspension Cross Member Bolt	5/8"	160-180	
8.	Frame Attachment Bolts	3/4"	(See below*)	
9.	PIVOT BOLT CONNECTION	7/8"	On the nut: 575	On the bolt: 475
10.	Wheel Flange Nuts	M22 x 1.5	(See below*)	

***IMPORTANT:**

TORQUE VALUES SHOWN ABOVE APPLY ONLY TO HENDRICKSON-SUPPLIED FASTENERS. USE ONLY HENDRICKSON GENUINE PARTS WHEN SERVICING THIS SUSPENSION SYSTEM. CONTACT HENDRICKSON CUSTOMER SERVICE FOR ASSISTANCE WITH ORDERING COMPOSILITE® EXF PARTS.



NOTE ¹ :	HENDRICKSON DOES NOT SUPPLY FASTENERS FOR THE INSTALLATION OF YOUR LIFT AXLE TO THE TRUCK RAIL OR TRAILER SUB-FRAME. HENDRICKSON DOES REQUIRE THAT YOU SELECT ¾" 16 SAE GRADE-8 BOLTS, HARDENED FLAT WASHERS, AND IFI (INDUSTRIAL FASTENERS INSTITUTE) ¾" GRADE-8 PREVAILING-TORQUE TYPE, STEEL HEX FLANGE NUTS. TORQUE SPECIFICATIONS VARY DEPENDING ON THE MANUFACTURER; THEREFORE, THE INSTALLER AND / OR THE OWNER-OPERATOR MUST FOLLOW TORQUE GUIDELINES FOR THE SPECIFIC FASTENERS SELECTED FOR INSTALLATION.
NOTE ² :	CONTACT WHEEL MANUFACTURER FOR TORQUE SPECIFICATIONS.

SECTION 12 TROUBLE-SHOOTING GUIDE

PROBLEM	POSSIBLE CAUSE	CORRECTION
Not getting the desired load on the axle	Absence of proper air pressure to the ride air springs	a. Adjust the air pressure at regulator valve b. Verify sufficient pressure to the air control system
	Air control system not properly installed	Check plumbing of air system, refer to Hendrickson Technical Publication Number H817
	Lift axle mounted too high Incorrect ride-height specification	a. Use larger tire b. Change height of axle seat
Unit not getting the correct lift	Lift air springs not getting proper air pressure	a. Check system pressure b. Check air system plumbing, refer to Hendrickson Technical Publication Number H817 c. Check air spring pressure
	Interference with chassis, drive line or other components	Inspect for interference and eliminate obstructions
	Unit not installed properly	Check installation instructions in this publication.
Unit has vertical hop	Not running sufficient load	Increase air pressure
	Unbalanced tires	Balance tires

SECTION 13 APPROVED WHEEL END CONFIGURATIONS

For more detailed information about approved wheel-end configurations, we recommend that you contact Hendrickson Customer Service: liftaxle@hendrickson-intl.com.

WHEEL-END LITERATURE

The following literature pertains to wheel end options available on Hendrickson Auxiliary Lift Axle Suspension Systems. The latest revisions of these documents can be found online: <https://www.hendrickson-intl.com>.



Product	Title/Description	Lit. #
HXL3®	Trailer Suspension Systems: Wheel-End System, Hub Maintenance Procedures	T72006
HXL5®	Trailer Suspension Systems: Wheel-End System, Hub Maintenance Procedures	T72007
TIREMAAX®	TIREMAAX® PRO and CP Tire Inflation Systems: Installation, Service & Trouble-Shooting Procedures	T51002

Approved Wheel End Configurations: Drum Brakes			
Spindles & Wheels	15x4		
	TIREMAAX*	HXL3 and HXL5	[H] STANDARD
N-Spindle with Single wheels dished OUT	YES at 13,500 LBS. AXLE RATING	YES at 13,500 LBS. AXLE RATING	YES at 13,500 LBS. AXLE RATING
P-Spindle with Single wheels dished OUT 16.5" or higher RH only	YES at 13,500 LBS. AXLE RATING	YES at 13,500 LBS. AXLE RATING	YES at 13,500 LBS. AXLE RATING
FF (Truck Spindle) with Single wheels dished IN	NO	NO	YES at 13,500 LBS. AXLE RATING

*Tire Pressure Control System

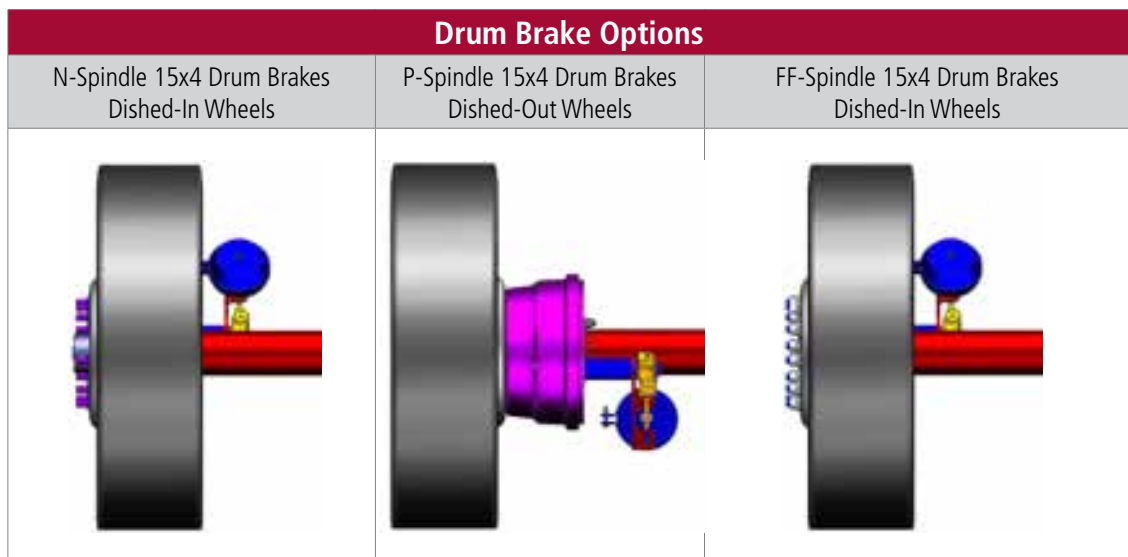



Approved Wheel End Configurations: Disc Brakes			
Spindles & Wheels	HENDRICKSON MAAX22T™		
	HXL3 and HXL5	HXL3®, HXL5® and TIREMAAX®*	[H] STANDARD
P-Spindle Single wheels dished OUT 16.5" or higher RH only	YES at 12,200 LBS. AXLE RATING	YES at 12,200 LBS. AXLE RATING	YES at 12,200 LBS. AXLE RATING
FF (Truck Spindle) Single wheels dished IN	TM	NO	TBD

Spindles & Wheels	Bendix ADB22x		
	HXL3 and HXL5	HXL3®, HXL5® and TIREMAAX®*	[H] STANDARD
P-Spindle Single wheels dished OUT 16.5" or higher RH only	YES at 11,000 LBS. AXLE RATING	YES at 11,000 LBS. AXLE RATING	YES at 11,000 LBS. AXLE RATING
FF (Truck Spindle) Single wheels dished IN	NO	NO	YES at 13,500 LBS. AXLE RATING

*Tire Pressure Control System

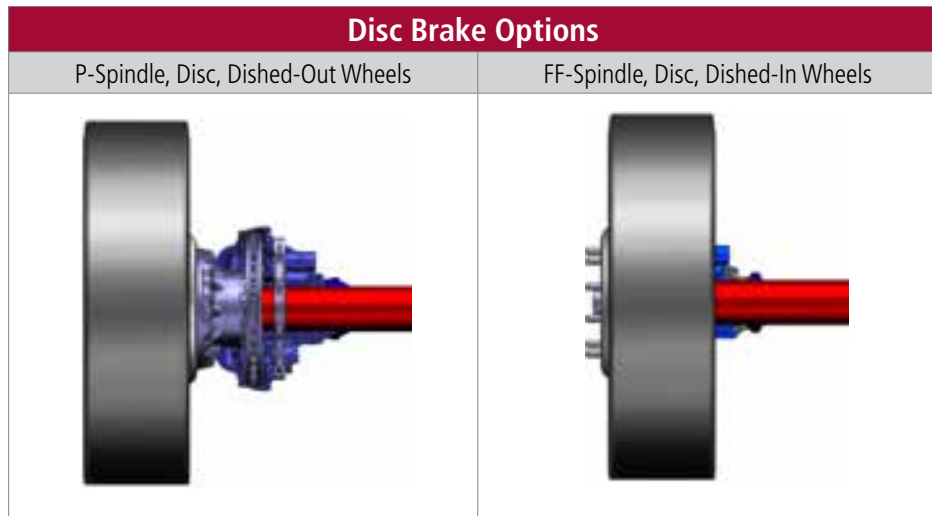

SECTION 14

TRAILER MOUNT DRAWINGS

Trailer Hanger Mount (Bolt-On):

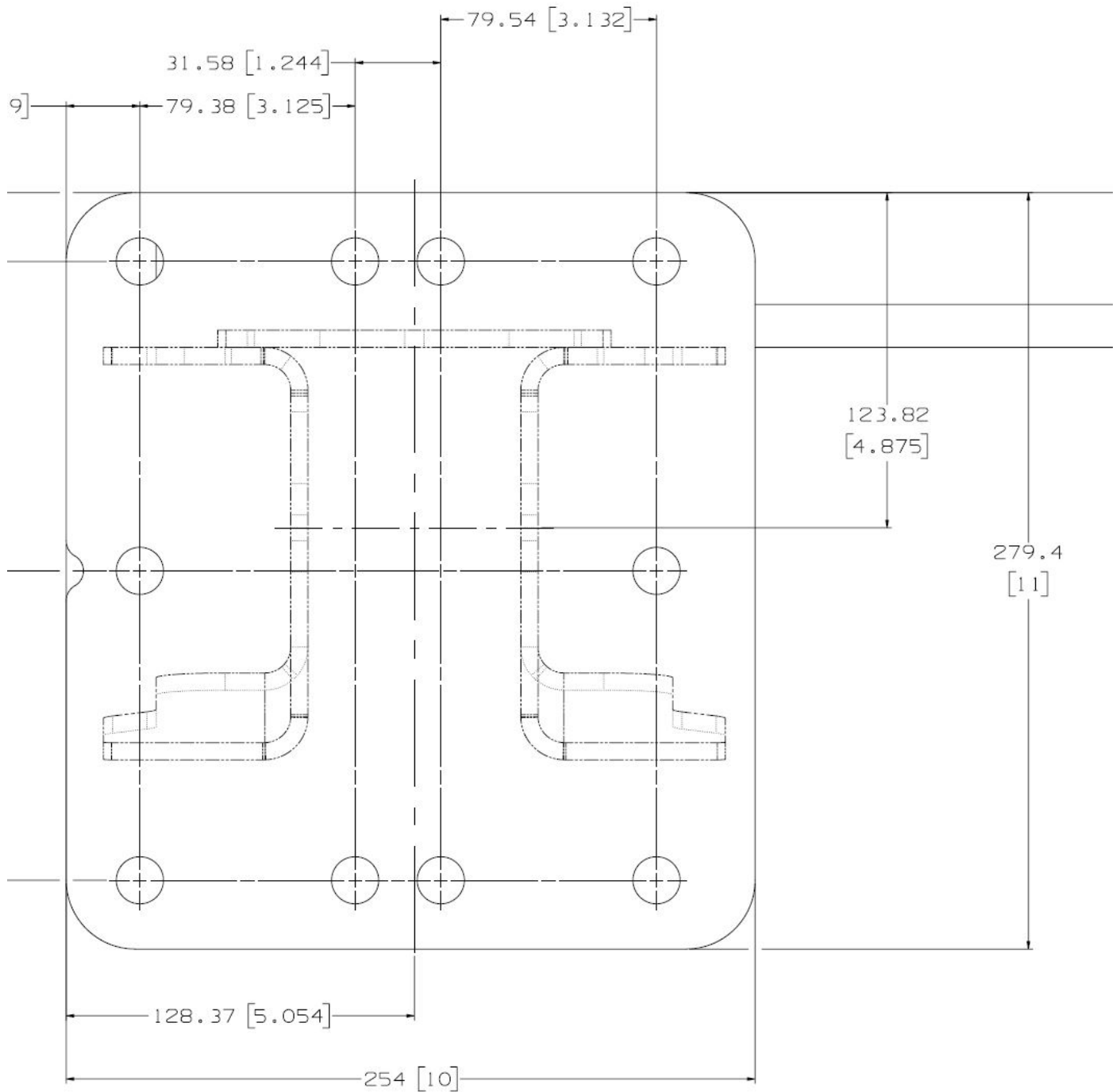



Trailer Ride Spring Mount (Bolt-On):

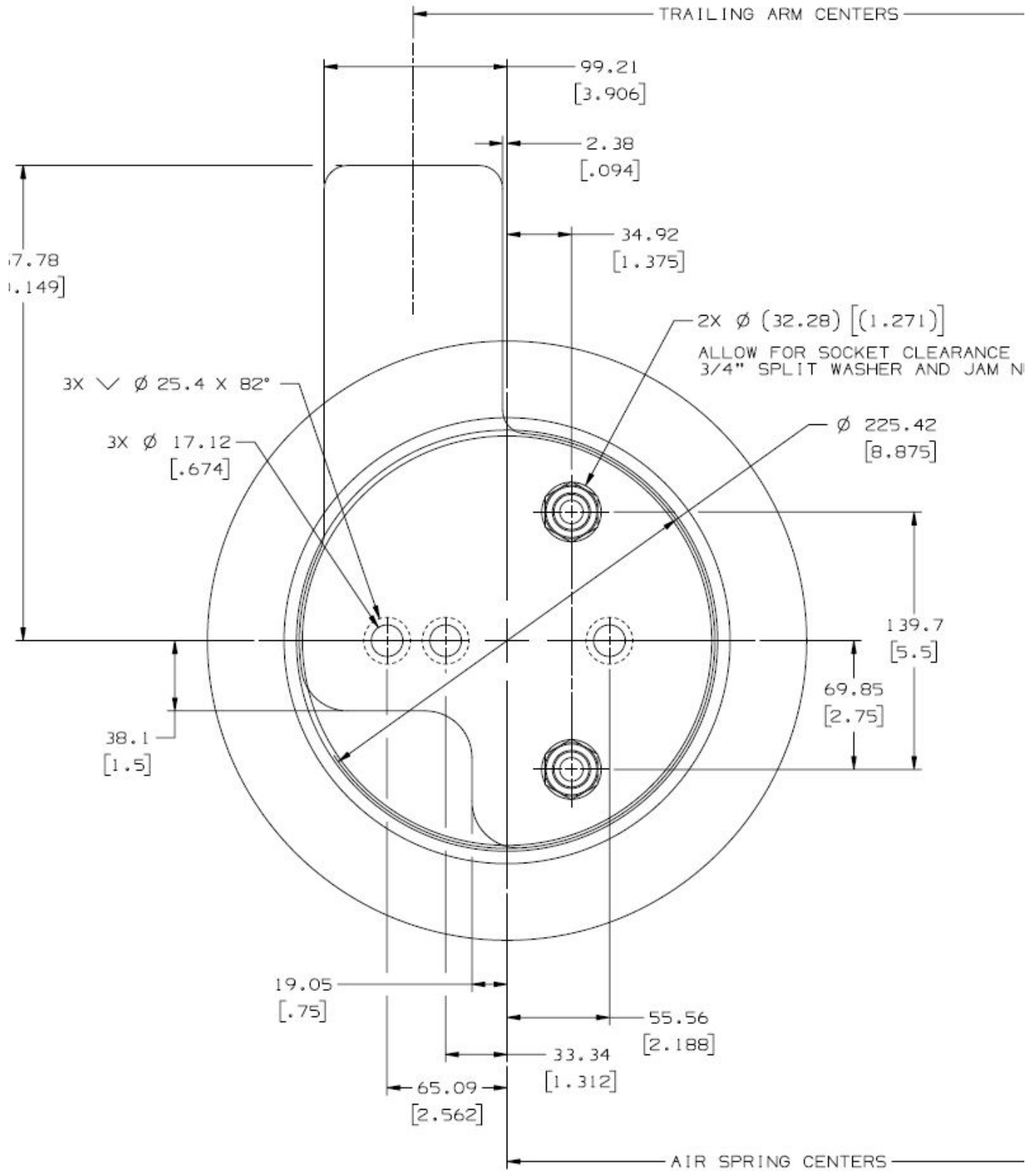



Trailer Hanger Mount (Weld-On):

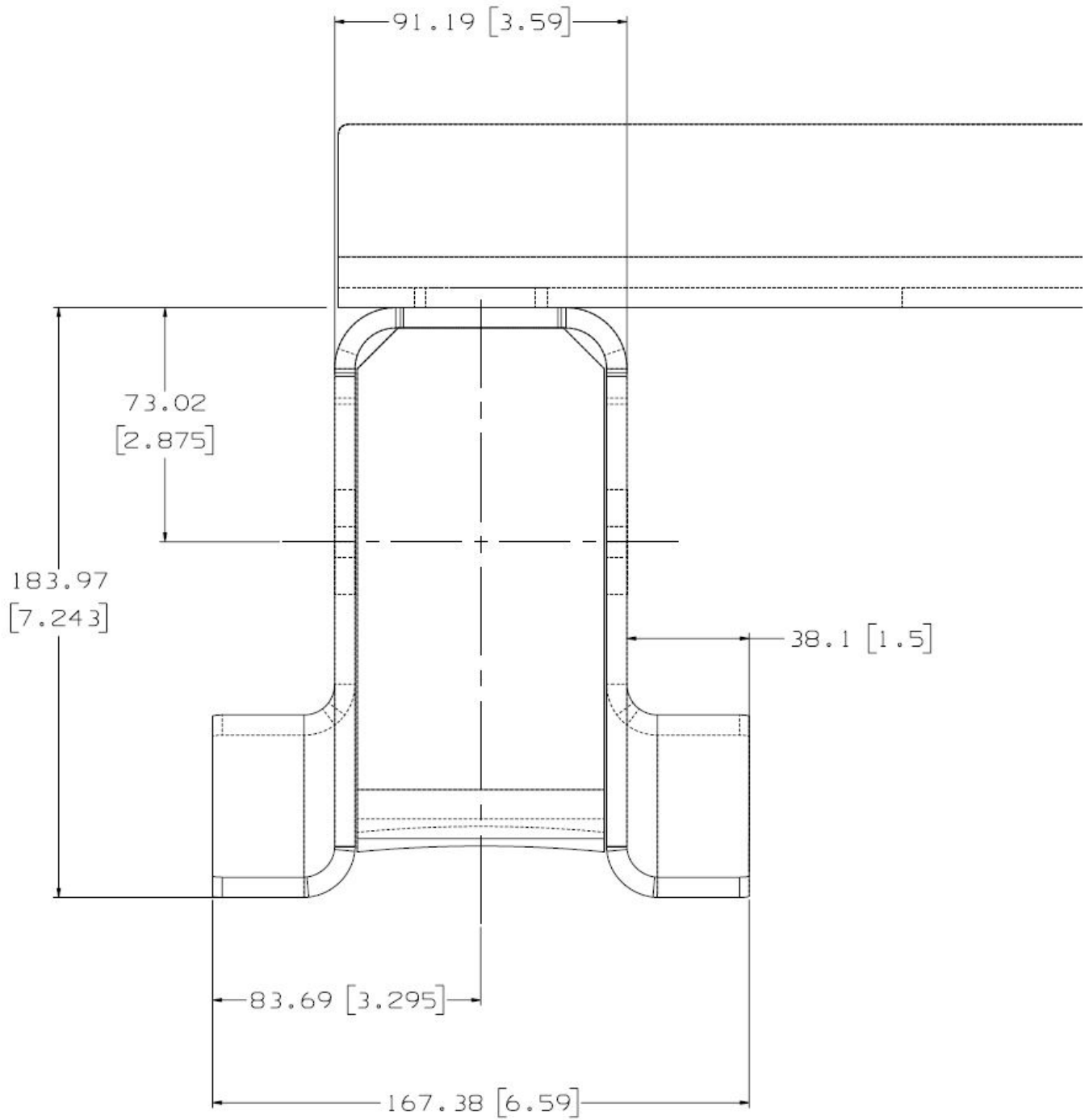



Trailer Ride Spring Mount (Weld-On):

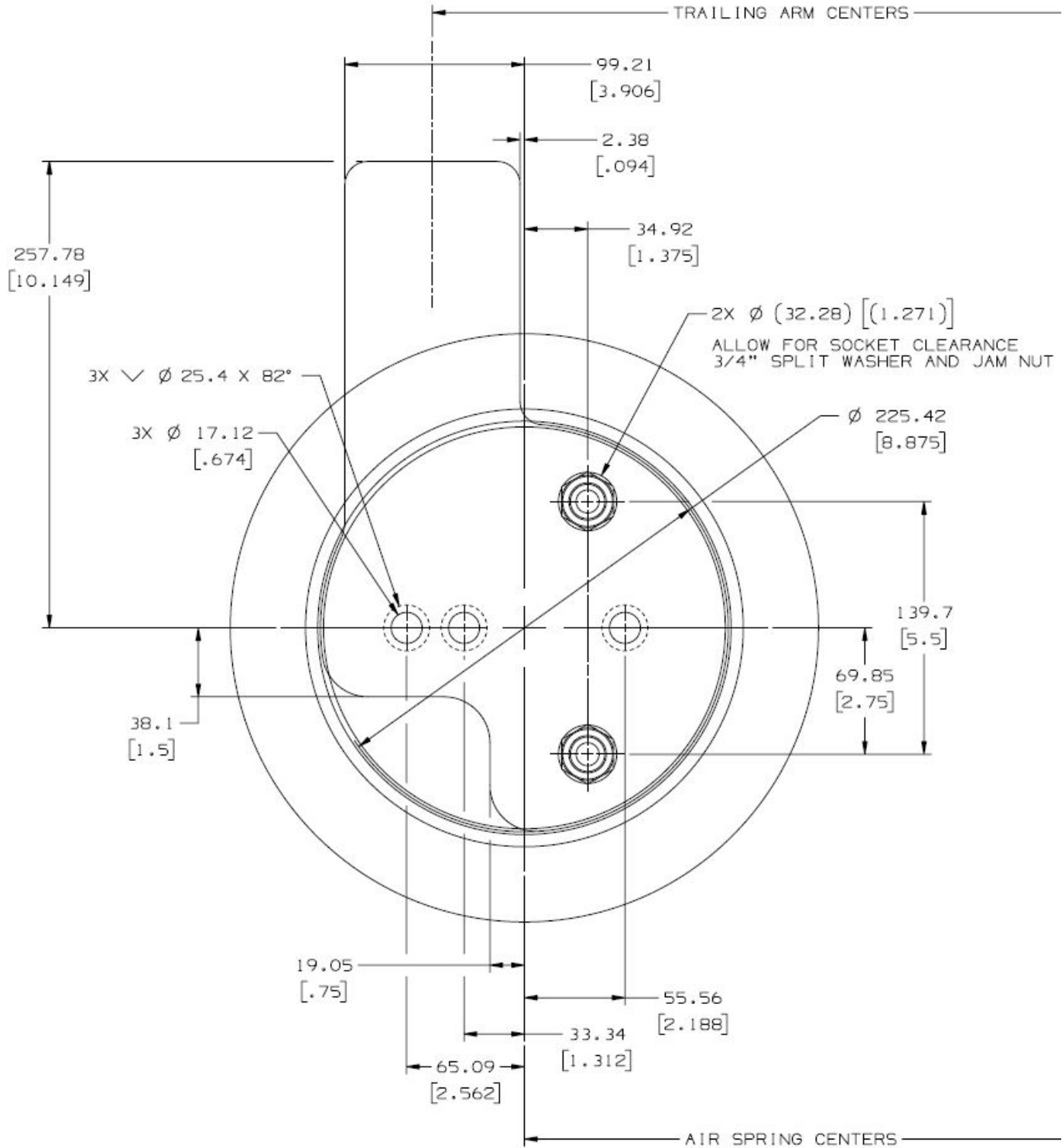

Actual product performance may vary depending upon vehicle configuration, operation, service and other factors.

All applications must comply with applicable Hendrickson specifications and must be approved by the respective vehicle manufacturer with the vehicle in its original, as-built configuration. Contact Hendrickson for additional details regarding specifications, applications, capacities, and operation, service and maintenance instructions.

Call Hendrickson at **800.660.2829** or **800.668.5360** in Canada for additional information.



www.hendrickson-intl.com

**SPECIALTY PRODUCTS -
AUXILIARY AXLE SYSTEMS**
277 North High Street
Hebron, OH 43025 USA
800.660.2829
740.929.5600 • FAX 740.929.5601

Hendrickson Canada ULC
2825 Argentia Road, Unit #2 - 4
Mississauga, ON Canada L5N 8G6
800.668.5360
905.789.1030 • Fax 905.802.9423

H818 Rev C 06-23

© 2022 - 2023 Hendrickson USA, L.L.C. All Rights Reserved. All trademarks shown are owned by Hendrickson USA, L.L.C., or one of its affiliates, in one or more countries. Information contained in this literature was accurate at the time of publication. Product changes may have been made after the copyright date that are not reflected.

Printed in United States of America