

H TECHNICAL PROCEDURE

AIRTEK® NXT Front Air Suspension and Steer Axle System for Engine & Accessory Manufacturing Inc. (EAM) Vehicles

SUBJECT: Service Instructions

LIT NO: 17730-280

DATE: February 2026

REVISION: A

TABLE OF CONTENTS

Section 1	Introduction	2			
Section 2	Product Description	2			
Section 3	Important Safety Notice	4			
Section 4	Special Tools	9			
Section 5	Parts List	10			
Section 6	Towing Procedures	17			
Section 7	Preventive Maintenance				
	Hendrickson Recommended Inspection Intervals	18			
	Component Inspection	18			
	Lubrication Intervals	20			
	Kingpin Lubrication	20			
	Tie Rod Ends	21			
	Clamp Group Retorque Intervals	23			
	Axle Collar Through Bolts	24			
	Axle Seat Liner	24			
	QUIK-ALIGN Connection	24			
	Kingpin Bushing Wear	25			
	Steering Knuckle	26			
	Shock Absorber	27			
	TRAAX ROD Transverse Torque Rods	28			
	Visual Tire Inspection	29			
	Wheel End and Air Disc Brake Assemblies and Components	30			
Section 8	Alignment & Adjustments				
	Alignment Definitions	31			
	Inspection Prior to Alignment	33			
	Front Wheel Alignment	34			
	Steering Stop	35			
	Toe Setting	37			
	Ride Height	39			
	Wheel End and Air Disc Brake Assemblies and Components	40			
Section 9	Component Replacement				
	Fasteners	41			
	Air Spring	41			
	Axle Bracket	42			
	Height Control Valve and Linkage Assembly	43			
	Shock Absorber	45			
	TRAAX ROD Torque Rods	45			
	Frame Hanger	46			
	Leaf Spring & Clamp Group Assembly – Module	48			
	Leaf Spring & Clamp Group assembly – Components	50			
	STEERTEK NXT high-capacity Axle	52			
	Steering Knuckle Components	54			
	Kingpin Bushing	55			
	Tie Rod Ends and Cross Tube	65			
	Wheel End and Air Disc Brake Assemblies and Components	66			
Section 10	Plumbing Diagram	67			
Section 11	Torque Specifications	68			
Section 12	Alignment Specifications	73			
Section 13	Troubleshooting Guide	74			
Section 14	Reference Material	76			

SECTION 1 Introduction

This publication is intended to acquaint and assist maintenance personnel in the preventive maintenance, service, repair and rebuild of the Hendrickson AIRTEK® NXT integrated front air suspension with STEERTEK™ NXT high-capacity single and twin steer axle system for applicable Engine & Accessory Manufacturing Inc. (EAM) truck vehicles.

NOTE

Use only Hendrickson Genuine Parts for servicing this suspension system.

It is important to read and understand this entire Technical Procedure publication and all work instructions and safety related information provided by the vehicle manufacturer prior to performing any maintenance, service, repair, or rebuild of this product. The information in this publication contains parts lists, safety information, product specifications, features, proper maintenance, service, repair, and rebuild instructions for the AIRTEK NXT single and twin steer front air suspension system.

Hendrickson reserves the right to make changes and improvements to its products and publications at any time. Contact Hendrickson Tech Services for information on the latest version of this manual at 855.743.3733 (toll-free U.S. and Canada), 1-630-910-2800 (outside U.S. and Canada) or email: wdtechservices@hendrickson-intl.com.

The latest revision of this publication is available online at www.hendrickson-intl.com.

SECTION 2 Product Description

FIGURE 2-1

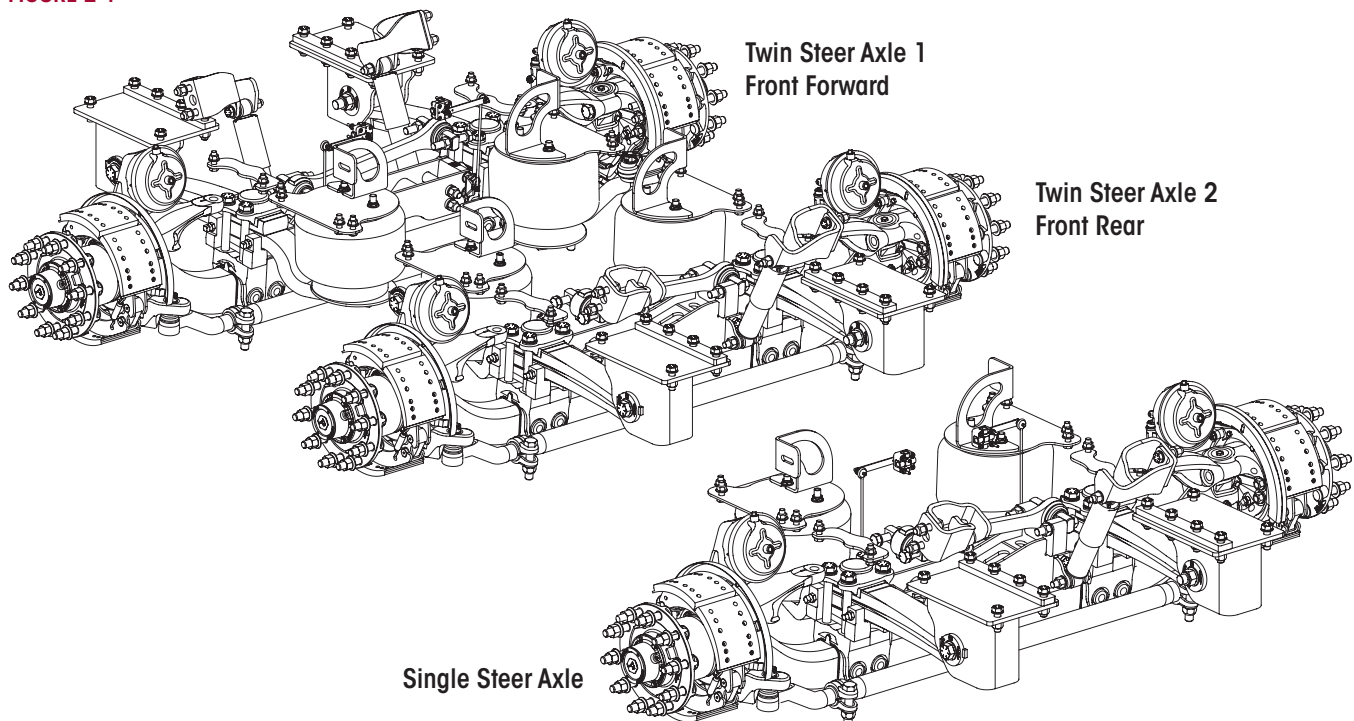



AIRTEK NXT integrated front air suspension and steer axle system is optimized to deliver maximum performance as a complete system solution. The fabricated STEERTEK NXT high-capacity axle design integrates lightweight axle durability with Hendrickson's advanced air suspension technology, assisting in protecting drivers from road irregularities and hazards while providing a premium ride.

AIRTEK NXT system has multiple configuration options and is available in single or twin steer and trailing- or leading-arm configurations. AIRTEK NXT system provides superior maneuverability with up to 35° of wheel cut for tight spaces such as job sites and city streets.

- **Air springs** — Exclusive air springs support a majority of the load to provide a low spring rate and helps to improve ride.
- **Leaf spring & clamp group assembly** — With its innovative design, the leaf spring provides superior roll stability, performance and a soft ride. Clamp group consists of top pad, bottom cap, axle seat, axle seat liners, hex bolts, washers and spherical washers.
- **QUIK-ALIGN®** — reduces maintenance time by offering a fast and easy method to adjust and set alignment without shims. Premium kingpin bushings and seals provide enhanced protection from the elements to improve bushing life.
- **Longitudinal torque rod** — Optimized configuration helps improve handling and roll stiffness for expanded applications. Premium retained rubber bushings for increased service life and resistance to walkout. Designed for optimum clearance and articulation.

STEERTEK NXT High-capacity axle and advanced clamp group design — The box-shaped cross section resists horizontal, vertical and twisting forces more effectively than traditional I-beam axles which improves handling. Continuous beam architecture minimizes stress points for added durability. It weighs less than original I-beam and spring clamp group.

- **Adjustable Tie Rod** — To help maximize tire life, the tie rod easily adjusts toe-in/out.
- **Steering Knuckles** — The steering and tie rod arms are integrated for increased strength and reduced weight. The two piece knuckle design makes replacing the kingpin bushings easier by eliminating the need to remove the kingpins. Premium kingpin bushings and seals provide enhanced protection from the elements to improve bushing life.

TECHNICAL NOTES

1. AIRTEK NXT system is approved for capacities up to 27,500 pounds per axle is approved for on-highway usage. Other applications must be pre-approved by both Hendrickson and EAM. System capacity represents maximum loads on tires at ground level.
2. AIRTEK NXT system is available with a track axle 70.86" Intersections (KPI).
3. AIRTEK NXT system offers a 3" axle drop height when combined with the axle seat. Axle drop when measured from the kingpin intersection to the top of the axle is 4.875".
4. AIRTEK NXT system is equipped with anti-lock braking system (ABS) ready. This system is compatible with industry standard wheel ends and brakes.
5. STEERTEK NXT High-capacity axle product identification is etched on the front of the axle providing the following information, see Figure 2-2:
 - Axle part number: Identifies the features of the axle
 - Wheel end assembly number: Identifies the complete assembly, which includes the steering knuckles, steering arms, tie rod assemblies, and brakes.

FIGURE 2-2

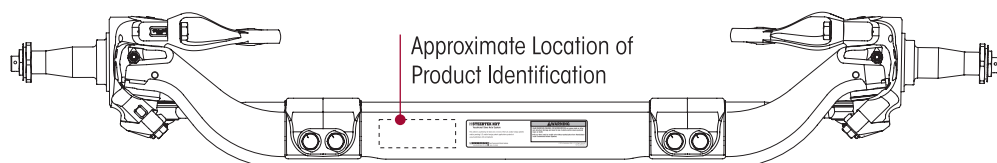

SECTION 3

Important Safety Notice

Proper maintenance, service and repair is important to the reliable operation of the suspension. The procedures recommended by Hendrickson and described in this technical publication are methods of performing such maintenance, service and repair.

The warnings and cautions should be read carefully to help prevent personal injury and to assure that proper methods are used. Improper maintenance, service or repair may damage the vehicle, cause personal injury, render the vehicle unsafe in operation, or void manufacturer's warranty.

Failure to follow the safety precautions in this manual can result in personal injury and/or property damage. Carefully read and understand all safety related information within this publication, on all decals and all such materials provided by the vehicle manufacturer before conducting any maintenance, service or repair.

■ EXPLANATION OF SIGNAL WORDS

Hazard "Signal Words" (Danger-Warning-Caution) appear in various locations throughout this publication. Information accented by one of these signal words must be observed to help minimize the risk of personal injury to service personnel, or possibility of improper service methods which may damage the vehicle or render it unsafe.



This is the safety alert symbol. It is used to alert you to potential personal injury hazards. Obey all safety messages that follow this symbol to avoid possible injury or death.

Additional 'Notes' or 'Service Hints' are utilized to emphasize areas of procedural importance and provide suggestions for ease of repair. The following definitions indicate the use of these signal words as they appear throughout the publication.



INDICATES AN IMMINENTLY HAZARDOUS SITUATION WHICH, IF NOT AVOIDED, WILL RESULT IN SERIOUS INJURY OR DEATH.



INDICATES A POTENTIAL HAZARDOUS SITUATION WHICH, IF NOT AVOIDED, CAN RESULT IN SERIOUS INJURY OR DEATH.



INDICATES A POTENTIAL HAZARDOUS SITUATION WHICH, IF NOT AVOIDED, MAY RESULT IN MINOR OR MODERATE INJURY, OR PROPERTY DAMAGE.

NOTE

An operating procedure, practice condition etc., which is essential to emphasize.

SERVICE HINT

A helpful suggestion, which will make the servicing being performed a little easier and/or faster.

Also note that particular service operations may require the use of special tools designed for specific purposes. These special tools can be found in the Special Tools section of this publication.



The torque symbol alerts you to tighten fasteners to a specified torque value. Refer to Torque Specifications section of this publication.



■ SAFETY PRECAUTIONS

WARNING

FASTENERS

DISCARD USED FASTENERS. ALWAYS USE NEW FASTENERS TO COMPLETE A REPAIR. FAILURE TO DO SO COULD RESULT IN FAILURE OF THE PART, OR MATING COMPONENTS, LOSS OF VEHICLE CONTROL, POSSIBLE PERSONAL INJURY, OR PROPERTY DAMAGE.

LOOSE OR OVER TORQUED FASTENERS CAN CAUSE COMPONENT DAMAGE, LOSS OF VEHICLE CONTROL, PROPERTY DAMAGE, OR SEVERE PERSONAL INJURY. MAINTAIN CORRECT TORQUE VALUE AT ALL TIMES. CHECK TORQUE VALUES ON A REGULAR BASIS AS SPECIFIED, USING A TORQUE WRENCH THAT IS REGULARLY CALIBRATED. TORQUE VALUES SPECIFIED IN THIS TECHNICAL PUBLICATION ARE FOR HENDRICKSON SUPPLIED FASTENERS ONLY. IF NON-HENDRICKSON FASTENERS ARE USED, FOLLOW THE TORQUE SPECIFICATIONS LISTED IN THE VEHICLE MANUFACTURER'S SERVICE MANUAL.

WARNING

LOAD CAPACITY

ADHERE TO THE PUBLISHED CAPACITY RATINGS FOR THE SUSPENSIONS. ADD-ON AXLE ATTACHMENTS AND OTHER LOAD TRANSFERRING DEVICES CAN INCREASE THE SUSPENSION LOAD ABOVE THE RATED AND APPROVED CAPACITIES WHICH COULD RESULT IN FAILURE AND LOSS OF VEHICLE CONTROL, POSSIBLY CAUSING PERSONAL INJURY OR PROPERTY DAMAGE.

WARNING

SUPPORT THE VEHICLE PRIOR TO SERVICING

PLACE THE VEHICLE ON A LEVEL FLOOR AND CHOCK THE WHEELS TO PREVENT THE VEHICLE FROM MOVING OR ROLLING. DO NOT WORK AROUND OR UNDER A RAISED VEHICLE SUPPORTED BY ONLY A FLOOR JACK. ALWAYS SUPPORT A RAISED VEHICLE WITH RIGID SAFETY STANDS. FAILURE TO DO SO CAN CAUSE SERIOUS PERSONAL INJURY OR DAMAGE TO EQUIPMENT.

CAUTION

PROCEDURES AND TOOLS

A TECHNICIAN USING A SERVICE PROCEDURE OR TOOL WHICH HAS NOT BEEN RECOMMENDED BY HENDRICKSON MUST FIRST SATISFY THEMSELVES THAT NEITHER THEIR SAFETY NOR THE VEHICLE'S SAFETY WILL BE JEOPARDIZED BY THE METHOD OR TOOL SELECTED. INDIVIDUALS DEVIATING IN ANY MANNER FROM THE INSTRUCTIONS PROVIDED ASSUME ALL RISKS OF POTENTIAL PERSONAL INJURY OR DAMAGE TO EQUIPMENT INVOLVED.

WARNING

PERSONNEL PROTECTIVE EQUIPMENT

ALWAYS WEAR PROPER EYE PROTECTION AND OTHER REQUIRED PERSONAL PROTECTIVE EQUIPMENT TO HELP PREVENT PERSONAL INJURY WHEN PERFORMING VEHICLE MAINTENANCE, REPAIR OR SERVICE.

WARNING

MODIFYING COMPONENTS

DO NOT MODIFY OR REWORK PARTS WITHOUT AUTHORIZATION FROM HENDRICKSON. DO NOT SUBSTITUTE REPLACEMENT COMPONENTS NOT AUTHORIZED BY HENDRICKSON. USE OF MODIFIED, REWORKED, SUBSTITUTE OR REPLACEMENT PARTS NOT AUTHORIZED BY HENDRICKSON MAY NOT MEET HENDRICKSON'S SPECIFICATIONS, AND CAN RESULT IN FAILURE OF THE PART, LOSS OF VEHICLE CONTROL, POSSIBLE PERSONAL INJURY OR PROPERTY DAMAGE, AND WILL VOID ANY APPLICABLE WARRANTIES. USE ONLY HENDRICKSON AUTHORIZED REPLACEMENT PARTS.

WARNING

TORCH / WELDING

DO NOT USE A CUTTING TORCH TO REMOVE ANY ATTACHING FASTENERS. THE USE OF HEAT ON SUSPENSION COMPONENTS WILL ADVERSELY AFFECT THE STRENGTH OF THESE PARTS. A COMPONENT DAMAGED IN THIS MANNER CAN RESULT IN THE LOSS OF VEHICLE CONTROL AND POSSIBLE PERSONAL INJURY OR PROPERTY DAMAGE.

EXERCISE EXTREME CARE WHEN HANDLING OR PERFORMING MAINTENANCE IN THE AREA OF THE MAIN SUPPORT MEMBER. DO NOT CONNECT ARC WELDING GROUND LINE TO THE MAIN SUPPORT MEMBER. DO NOT STRIKE AN ARC WITH THE ELECTRODE ON THE MAIN SUPPORT MEMBER. DO NOT USE HEAT NEAR THE MAIN SUPPORT MEMBER ASSEMBLY. DO NOT NICK OR GOUGE THE MAIN SUPPORT MEMBER. SUCH IMPROPER ACTIONS CAN DAMAGE TO THE MAIN SUPPORT MEMBER ASSEMBLY AND CAN CAUSE AND CAN CAUSE LOSS OF VEHICLE CONTROL AND POSSIBLE PERSONAL INJURY OR PROPERTY DAMAGE.



AIR SPRINGS

AIR SPRING ASSEMBLIES MUST BE COMPLETELY DEFLATED PRIOR TO LOOSENING ANY CLAMP GROUP HARDWARE. UNRESTRICTED AIR SPRING ASSEMBLIES CAN VIOLENTLY SHIFT. DO NOT INFLATE AIR SPRING ASSEMBLIES WHEN THEY ARE UNRESTRICTED. AIR SPRING ASSEMBLIES MUST BE RESTRICTED BY SUSPENSION OR OTHER ADEQUATE STRUCTURE. DO NOT INFLATE BEYOND PRESSURES RECOMMENDED BY AIR SPRING MANUFACTURER, CONTACT HENDRICKSON TECHNICAL SERVICES FOR DETAILS. IMPROPER USE OR OVER INFLATION MAY CAUSE AIR SPRING ASSEMBLIES TO BURST, CAUSING PROPERTY DAMAGE AND / OR SEVERE PERSONAL INJURY.



WHEN SERVICING THE VEHICLE OR ATTACHING AN AIR SPRING, AND THE VEHICLE IS ON THE GROUND PRIOR TO AIRING UP THE SUSPENSION SYSTEM, MAKE CERTAIN THE AIR SPRING LOCATOR IS INDEXED INTO THE UPPER AIR SPRING FRAME BRACKET PROPERLY AND THE AIR SPRING IS FULLY SEATED ON THE AIR SPRING FRAME BRACKET. FAILURE TO FOLLOW THESE INSTRUCTIONS CAN RESULT IN PREMATURE AIR SPRING FAILURE AND CAUSE PERSONAL INJURY, OR PROPERTY DAMAGE.

PRIOR TO AND DURING DEFLATION AND INFLATION OF THE FRONT AIR SUSPENSION SYSTEM, ENSURE THAT ALL PERSONNEL AND EQUIPMENT ARE CLEAR FROM UNDER THE VEHICLE AND AROUND THE SERVICE AREA. FAILURE TO DO SO CAN CAUSE SERIOUS PERSONAL INJURY, DEATH, OR PROPERTY DAMAGE.



SHOCK ABSORBERS

THE SHOCK ABSORBERS ARE THE REBOUND TRAVEL STOPS FOR THE SUSPENSION. ANYTIME THE AXLE ON AIRTEK NXT SUSPENSION IS SUSPENDED IT IS MANDATORY THAT THE SHOCK ABSORBERS REMAIN CONNECTED. FAILURE TO DO SO CAN CAUSE THE AIR SPRINGS TO SEPARATE FROM THE PISTON AND RESULT IN PREMATURE AIR SPRING FAILURE. REPLACEMENT OF SHOCK ABSORBERS WITH NON-HENDRICKSON PARTS CAN ALTER THE REBOUND TRAVEL OF THE SUSPENSION.



TORQUE RODS

THIS HENDRICKSON SUSPENSION SYSTEM REQUIRES TORQUE RODS FOR SUSPENSION PERFORMANCE AND VEHICLE STABILITY. IF THESE TORQUE RODS ARE DISCONNECTED OR ARE NON-FUNCTIONAL, DO NOT OPERATE THE VEHICLE. OPERATING A VEHICLE WITH DISCONNECTED OR NON-FUNCTIONAL TORQUE RODS CAN RESULT IN ADVERSE VEHICLE HANDLING, COMPONENT DAMAGE, SUSPENSION/VEHICLE DAMAGE, AND/OR SEVERE PERSONAL INJURY.



UNAUTHORIZED REPAIR OR RECONDITIONING

THE REPAIR OR RECONDITIONING OF SUSPENSION OR AXLE COMPONENTS IS NOT ALLOWED AS SHOWN ON LABEL IN FIGURE 3-1 . ANY AXLE COMPONENTS FOUND TO BE DAMAGED OR OUT OF SPECIFICATIONS MUST BE REPLACED. ALL MAJOR COMPONENTS ARE HEAT TREATED AND TEMPERED. THE COMPONENTS CANNOT BE BENT, WELDED, HEATED, OR REPAIRED WITHOUT REDUCING THE STRENGTH OR LIFE OF THE COMPONENT. FAILURE TO FOLLOW THESE GUIDELINES CAN CAUSE LOSS OF VEHICLE CONTROL, POSSIBLE PERSONAL INJURY, DEATH, OR PROPERTY DAMAGE AND WILL VOID APPLICABLE WARRANTIES.

NOTE: REPLACE ANY SAFETY DECALS THAT ARE FADED, TORN, MISSING, ILLEGIBLE, OR OTHERWISE DAMAGED. CONTACT HENDRICKSON TO ORDER REPLACEMENT LABELS.

FIGURE 3-1

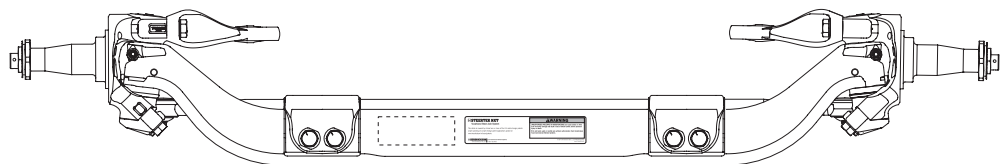
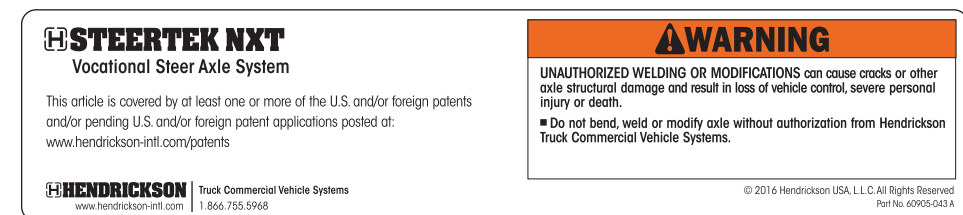



WARNING

STEERTEK NXT HIGH-CAPACITY AXLE

UNAUTHORIZED WELDING OR MODIFICATIONS CAN CAUSE CRACKS OR OTHER AXLE STRUCTURAL DAMAGE AND RESULT IN LOSS OF VEHICLE CONTROL, SEVERE PERSONAL INJURY OR DEATH. DO NOT BEND, WELD OR MODIFY AXLE WITHOUT AUTHORIZATION FROM HENDRICKSON TRUCK COMMERCIAL VEHICLE SYSTEMS.

WARNING

DAMAGED AXLE COMPONENTS

IF A VEHICLE EQUIPPED WITH A STEERTEK NXT HIGH-CAPACITY AXLE IS INVOLVED IN A CRASH, THE AXLE STEER KNUCKLES MUST BE DISASSEMBLED AND A THOROUGH INSPECTION OF THE AXLE MUST BE PERFORMED NOTING THE CONDITION OF THE AXLE BEAM, KINGPINS, AND KNUCKLE ASSEMBLIES, INCLUDING THE AREAS OF AXLE TO KINGPIN INTERFACE FOR ANY DAMAGE, GAPS, KINGPIN MOVEMENT OR PLAY. IF ANY COMPONENT APPEARS DAMAGED, OR THE KINGPINS APPEAR TO CONTAIN ANY DAMAGE, GAPS, MOVEMENT OR PLAY, THE COMPLETE AXLE ASSEMBLY MUST BE REPLACED.

IN ADDITION, IN THE EVENT A CRASH RESULTS IN EXCESSIVE SIDE LOAD DAMAGE TO ADJACENT PARTS, SUCH AS A BENT WHEEL, HUB, OR SPINDLE, IT IS STRONGLY RECOMMENDED TO REPLACE THE COMPLETE AXLE ASSEMBLY.

CONTACT HENDRICKSON TECHNICAL SERVICES WITH ANY QUESTIONS. FAILURE TO REPLACE ANY DAMAGED COMPONENTS CAN CAUSE LOSS OF VEHICLE CONTROL, POSSIBLE PERSONAL INJURY, DEATH, OR PROPERTY DAMAGE AND WILL VOID ANY APPLICABLE WARRANTIES.

WARNING

AXLE CAMBER IS NOT ADJUSTABLE

DO NOT CHANGE THE AXLE CAMBER ANGLE OR BEND THE AXLE BEAM. BENDING THE AXLE BEAM TO CHANGE THE CAMBER ANGLE CAN DAMAGE THE AXLE AND REDUCE AXLE STRENGTH, WILL VOID WARRANTY, AS APPLICABLE AND CAN CAUSE LOSS OF VEHICLE CONTROL, POSSIBLY CAUSING PERSONAL INJURY OR PROPERTY DAMAGE.

WARNING

IMPROPER JACKING METHOD

IMPROPER JACKING METHOD CAN CAUSE STRUCTURAL DAMAGE AND RESULT IN LOSS OF VEHICLE CONTROL, SEVERE PERSONAL INJURY OR DEATH. DO NOT USE AXLE BEAM OUTBOARD OF AXLE SEATS FOR JACKING VEHICLE. REFER TO VEHICLE MANUFACTURER FOR PROPER JACKING INSTRUCTIONS.

WARNING

PARTS CLEANING

SOLVENT CLEANERS CAN BE FLAMMABLE, POISONOUS AND CAUSE BURNS. TO HELP AVOID SERIOUS PERSONAL INJURY, CAREFULLY FOLLOW THE MANUFACTURER'S PRODUCT INSTRUCTIONS AND GUIDELINES AND THE FOLLOWING PROCEDURE:

1. WEAR PROPER EYE PROTECTION
2. WEAR CLOTHING THAT PROTECTS YOUR SKIN
3. WORK IN A WELL VENTILATED AREA
4. DO NOT USE GASOLINE, OR SOLVENTS THAT CONTAIN GASOLINE. GASOLINE CAN EXPLODE
5. ACIDIC SOLUTIONS CANNOT BE USED ON ALUMINUM COMPONENTS
6. HOT SOLUTION TANKS OR ALKALINE SOLUTIONS MUST BE USED CORRECTLY. FOLLOW THE MANUFACTURER'S RECOMMENDED INSTRUCTIONS AND GUIDELINES CAREFULLY TO HELP PREVENT PERSONAL ACCIDENT OR INJURY

DO NOT USE HOT SOLUTION TANKS OR WATER AND ALKALINE SOLUTIONS TO CLEAN GROUND OR POLISHED PARTS. DOING SO WILL CAUSE DAMAGE TO THE PARTS AND VOID ANY APPLICABLE WARRANTY.

WARNING**OFF-ROADWAY TOWING**

WHEN A VEHICLE IS DISABLED AND EQUIPPED WITH A STEERTEK NXT HIGH-CAPACITY AXLE, CARE MUST BE TAKEN TO ENSURE THERE IS NO DAMAGE TO THE SUSPENSION OR AXLE WHEN TOWING THE VEHICLE. THE USE OF A TOW STRAP IS NECESSARY TO TOW A DISABLED VEHICLE TO A REPAIR FACILITY PARKING LOT INTO THE SHOP BAY. THE TOW STRAPS SHOULD BE CONNECTED TO THE TOW HOOKS PROVIDED BY THE VEHICLE MANUFACTURER AT THE FRONT OF THE BUMPER. IF THE USE OF TOW HOOKS IS NOT AN OPTION, THEN A TOW STRAP MAY BE WRAPPED AROUND THE FRONT AXLE, (SEE FIGURE 3-2) IN A MANNER THAT IS ACCEPTABLE FOR TOWING THE VEHICLE FROM A REPAIR FACILITY PARKING LOT INTO THE SHOP BAY. DO NOT USE A TOW CHAIN AROUND THE FRONT AXLE OR WITH A SINGLE POINT LOCATION TO TOW THE VEHICLE. DOING SO WILL DAMAGE THE AXLE AND VOID ANY APPLICABLE WARRANTY, SEE FIGURE 3-2. FOR DETAILED TOWING INSTRUCTIONS FOR ON-HIGHWAY TOWING, SEE TOWING PROCEDURES SECTION IN THIS PUBLICATION.

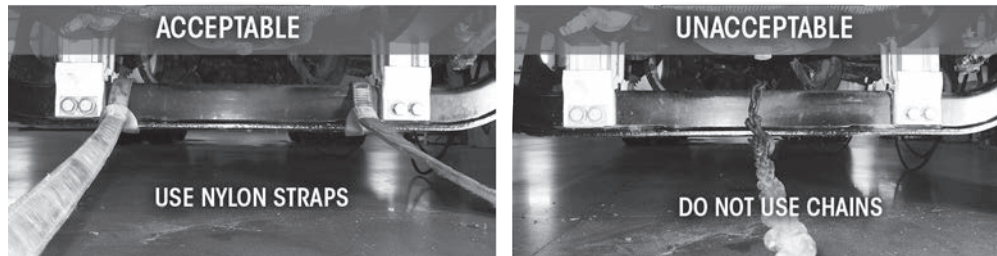
FIGURE 3-2**OFF-ROADWAY TOWING**



SECTION 4 Special Tools

KINGPIN BUSHING TOOLS

NOTE: Hendrickson does not supply these tools. Contact tool manufacturer.

ADJUSTABLE STRAIGHT FLUTE REAMER

2.000" to 2.010" Cutting Diameter

McMaster-Carr #3141A28



OR

PRECISION-FINISH CYLINDER HONE

1.75" to 2.75" Cylinder ID

McMaster-Carr #7362A45



EXTENSION PILOT TOOL

for 1.781" to 2.093" Adjustable Reamer

McMaster-Carr #3004A32



KINGPIN BUSHING AND SEAL SHOP MADE TOOLS

SHOP MADE TOOLS: These shop made tools are designed to install and remove kingpin bushings. Bushing tools are made from cold rolled steel or equivalent. Drawings are for reference only. Hendrickson does not supply these tools.

KINGPIN BUSHING DRIVER

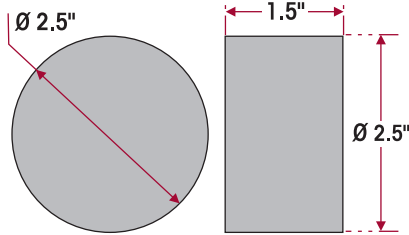

KINGPIN BUSHING REMOVER / INSTALLER

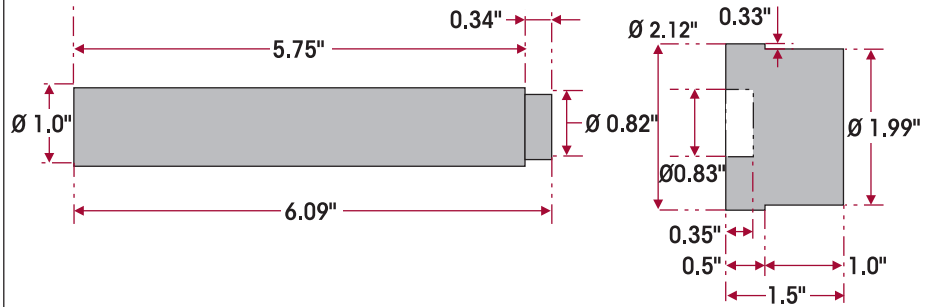

COLLAR DRIVER

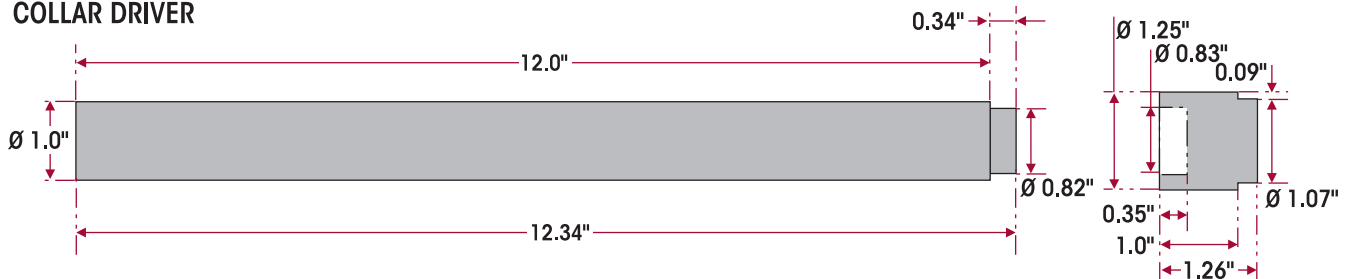

STEERING STOP BOLT JAM NUT TOOL

NOTE: Hendrickson does not supply these tools. Contact tool manufacturer.



DUAL OPEN-END WRENCH

1⁵/₁₆" - 60°/15° Angle Wrench

Martin Tools #3719



SECTION 5 Parts List

27.5K lb Capacity per Axle

Twin Steer • 7.2" Ride Height

Twin Steer Axle 1 Shown
Front Forward Axle

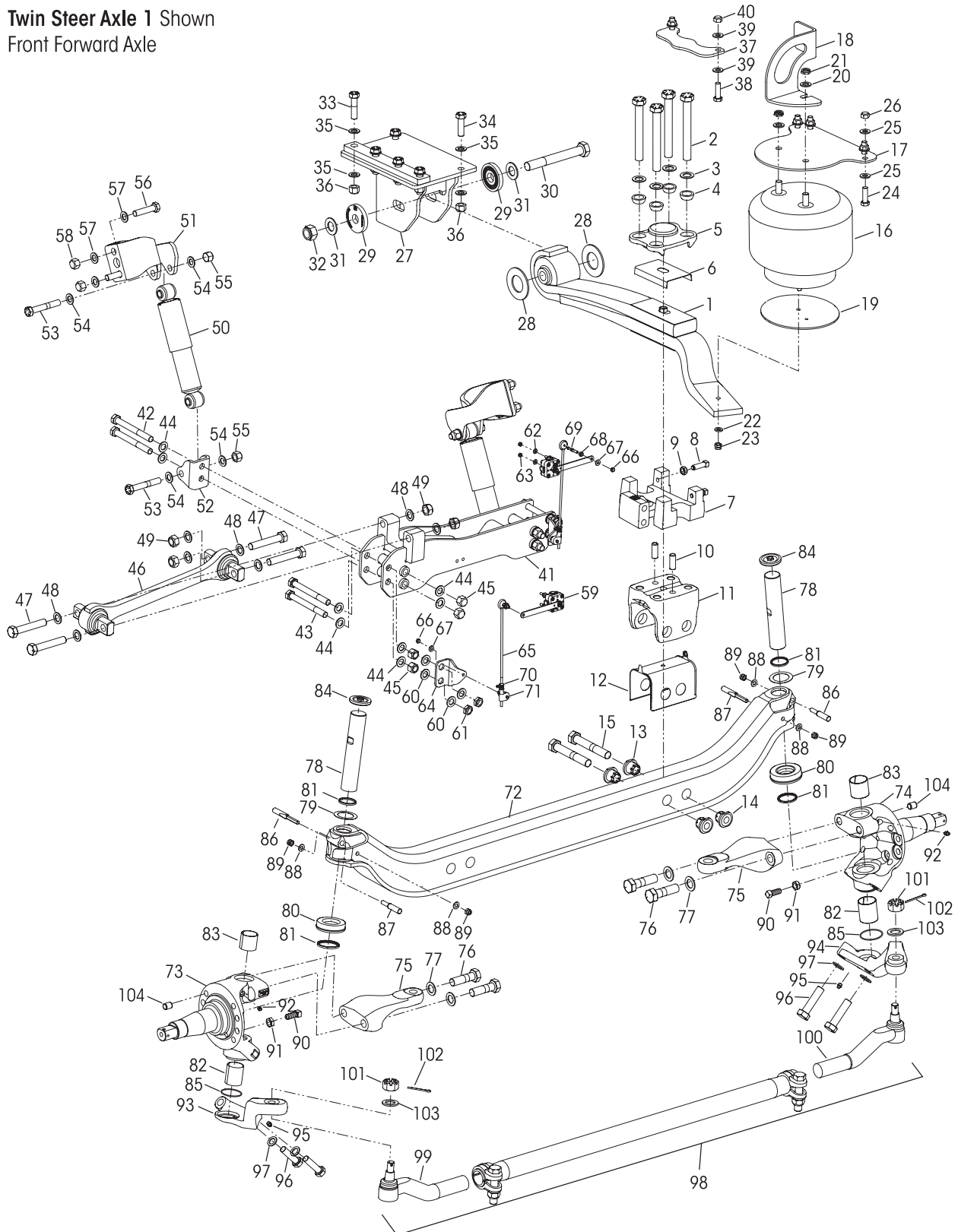



AIRTEK® NXT System for Engine & Accessory Manufacturing Inc. (EAM) Vehicles

KEY NO.	PART NO.	DESCRIPTION	VEHICLE QTY.
		Leaf Spring & Clamp Group Assembly, Includes Key Nos. 1-15	
	80002-301	Left Hand, Axle 1	1
	80002-302	Right Hand, Axle 1	1
	80002-201	Left Hand, Axle 2	1
	80002-202	Right Hand, Axle 2	1
1		Leaf Spring Assembly	
	82417-000	Left Hand, Axle 1 / Right Hand, Axle 2	2
	82418-000	Right Hand, Axle 1 / Left Hand, Axle 2	2
	34013-419	Clamp Group Fastener Service Kit, One Wheel End , Includes Key Nos 2-4, 6	
2		*1"-8 UNC x 8" Hex Bolt	16
3		*1" Flat Washer	16
4		*1" Spherical Washer	16
5	78888-000	Top Pad with Jounce Stop	4
6	79273-001	Leaf Spring Liner	4
7		Bottom Cap	
	80379-301	Left Hand	2
	80379-302	Right Hand	2
8	80483-001	5/8" x 2" Set Screw	8
9	17491-023	5/8"-11 UNC Jam Nut	8
10	18831-021	Dowel Pin	8
11	91799-000	Axle Seat	4
	34013-512	Axle Collar Service Kit, One Side , Includes Key Nos. 12-15	
12	78887-002	Axle Seat Liner	4
		*Axle Collar	
		Non Threaded, Bolt Side	8
		Threaded, Tie Rod Side	8
15		*1"-8 UNC x 6 1/2" Hex Bolt	8
16	91125-001	Air Spring Assembly	4
17	91797-100	Upper Air Spring Plate	4
18	91797-113	Upper Air Spring Z-Bracket	4
19	94338-101	Lower Air Spring Spacer	4
	91855-029	Air Spring Fastener Service Kit, One Side , Includes Key Nos.20-23	
20		*3/4" Upper Air Spring Flat Washer	8
21		*3/4"-16 UNF Upper Air Spring Locknut	8
22		*1/2" Lower Air Spring Hardened Washer	4
23		*1/2"-13 UNC Lower Air Spring Locknut	4
	49177-072	Air Spring Frame Mounting Fastener Kit, One Side , Includes Key Nos. 24-26	
24		*5/8"-11 UNC x 2" Hex Screw	16
25		*5/8" Flat Washer	32
26		*5/8"-11 UNC Nut	16
27		Frame Hanger	
	79819-101	Left Hand, Axle 1 / Right Hand, Axle 2	2
	79819-102	Right Hand, Axle 1 / Left Hand, Axle 2	2
	60632-048	QUIK-ALIGN Collar Service Kit, One Wheel End , Includes Key Nos. 28-32	
28		*Wear Pad	8
29		*QUIK-ALIGN Concentric Collar	8
30		*1 1/8" x 12 UNF x 9" Hex Bolt	4
31		*1 1/8" Hardened Washer	8
32		*1 1/8" x 12 UNF Locknut	4
	64105-016	Frame Hanger Mounting Fastener Kit, Axle Set Includes Key Nos. 33-36	
33		*3/4"-10 UNC x 3" Hex Bolt	16
34		*3/4"-10 UNC x 2 1/2" Hex Bolt	8
35		*3/4" Flat Washer	48
36		*3/4"-10 UNC Nut	24
37	94933-010	Jounce Stop, Front Left Hand & Right Hand	4
	49399-003	Jounce Stop Frame Mounting Fastener Kit, One side , Includes Key Nos. 38-40	
38		*5/8"-11 UNC x 2" Hex Screw	8
39		*5/8" Flat Washer	16
40		*5/8"-11 UNC Nut	8

KEY NO.	PART NO.	DESCRIPTION	VEHICLE QTY.
41	91796-001	Axle /TVTR Bracket	2
	58819-020	Axle /TVTR Bracket Fastener Kit, Axle Set , Includes Key Nos.42-45	
42		3/4"-10 UNC x 7" Hex Bolt	12
43		3/4"-10 UNC x 6 1/2" Hex Bolt	4
44		3/4" Flat Washer	24
45		3/4"-10 UNC Locknut	16
46	8232-0000-550	TRAAX ROD® Torque Rod Assembly	2
	58821-051	Torque Rod Fastener Service Kit, One Side , Includes Key Nos.47-49	
47		7/8"-14 UNF x 4 1/2" Hex Bolt	8
48		7/8" Flat Washer	16
49		7/8"-14 UNF Locknut	8
50	77538-003	Shock Absorber	4
51	95133-000	Upper Shock Bracket	4
52	91795-001	Lower Shock Bracket	4
	50754-091	Shock Absorber Fastener Kit, One Axle , Includes Key Nos. 53-55	
53		*3/4"-10 UNC x 4 3/4" Hex Bolt	8
54		*3/4" Flat Washer	16
55		*3/4"-10 UNC Locknut	8
	50754-093	Shock Bracket Frame Mounting Fastener Kit, One Side , Includes Key Nos. 56-58	
56		*3/4"-10 x 3 1/2" Hex Head Cap Screw	8
57		*3/4" Flat Washer	16
58		*3/4"-10 UNC-2b Nut	8
	58525-084	Height Control Valve Service Kit , Includes Key Nos. 59-63, 65	
59	60841-100	Height Control Valve Assembly	2
60		*3/4" Flat Washer	8
61		*3/4"-10 UNC Jam Nut	4
62		*1/4" Flat Washer	4
63		*1/4"-20 UNC Nut	4
64	91795-013	Lower Linkage Bracket	2
65		HCV Linkage Assembly, Includes Key Nos. 66-71	
	58994-090	Right Hand	1
	58994-091	Left Hand	1
	75841-003	HCV Frame Mounting Fastener Kit , Includes Key Nos. 66-68	
66		*5/16"-18 UNC Locknut	4
67		*5/16" Flat Hardened Washer	4
68		*5/16"-18 UNC Jam Nut	4
69		*5/16"-18 UNC Stud	4
70		*Valve Arm Clamp	2
71		*Adjustable Valve Arm Joint	2
72	79634-001	Axle Knuckle Assembly, Includes Key Nos. 82, 85, 90-92, 104	2
73	77243-001	Left Hand	2
74	77243-002	Right Hand	2
75	79685-006	Steering Arm	4
76	30550-040	1"-14 UNF x 3 1/4" Hex Bolt	8
77	22962-051	1" Flat Washer	8
	34013-230	Kingpin Service Kit, One Side Includes Key Nos. 78-89, 96-97	
78		*Kingpin	4
79		Kingpin Shim (As needed for service)	4
	a	77241-002 0.01" Thickness	
	b	77241-003 0.02"	
80	75918-001	Thrust Bearing	4
81	75966-001	Kingpin Seal	8
		Kingpin Bushing	
82	75919-001	Lower	4
83	75919-002	Upper	4
84	77209-001	Grease Cap	4
85	68303-004	O-Ring	4



KEY NO.	PART NO.	DESCRIPTION	VEHICLE QTY.	KEY NO.	PART NO.	DESCRIPTION	VEHICLE QTY.
		Kingpin Draw Key		97	22962-002	7/8" Flat Washer	8
86	75925-001	Upper, 33/8" Length	4	98	79365-002	Tie Rod Assembly, Heavy-duty, Drop	2
87	75925-002	Lower, 43/4" Length	4			Includes Key Nos. 99-101	
88	22962-054	7/16" Flat Washer	8			Tie Rod End Service Kits,	
89	17700-008	7/16"-14 UNC-2B Locknut	8		60961-884	Axle Set, Includes Kit Nos. 60961-882 and -883	
90	93334-001	5/8"-11 UNC x 1 1/2" Stop Bolt	4		60961-882	Left Hand, Includes Key Nos. 99, 101-102	
91	17491-023	5/8"-11 UNC-2B Jam Nut	4		60961-883	Right Hand, Includes Key Nos. 100-102	
92	33117-000	Grease Zerk	4			*Tie Rod End, Includes Key No. 101	
		Tie Rod Arm Assembly, Includes Key No. 95		99		Left Hand	2
93a	77244-075	Left Hand, Axle 1	1	100		Right Hand	2
b	77244-013	Left Hand, Axle 2 (Not Shown)	1	101		*7/8"-14 UNF-2A Castle Nut	4
94a	77244-076	Right Hand, Axle 1	1	102		*Cotter Pin	4
b	77244-014	Right Hand, Axle 2 (Not Shown)	1	103		*7/8" Flat Washer	4
95	33117-000	Grease Zerk	4	104	64246-000	ABS Sensor Sleeve	4
96	30418-014	7/8"-14 UNF x 3 1/2" Hex Bolt	8				

NOTES: Quantities specified are shown for a twin steer axle system, service kit components may vary from amount shown in lists.

* Item included in kit/assembly only, part not sold separately.



■ **Wheel End Assembly with Air Disc Brakes**

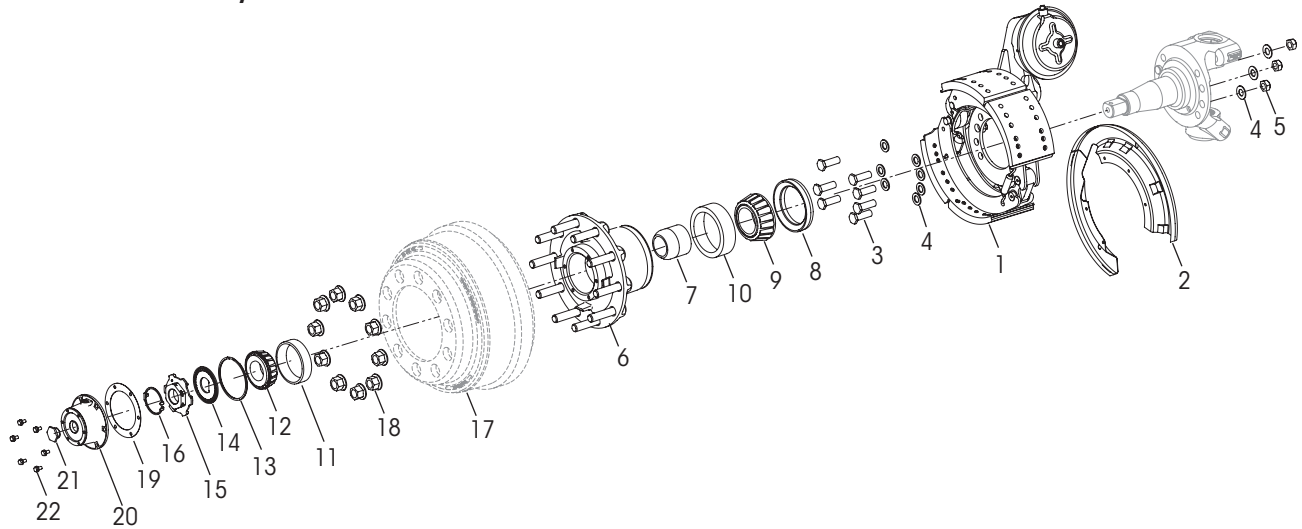

KEY NO.	PART NO.	DESCRIPTION	VEHICLE QTY.
1		*Meritor 16.5" x 6" Q-PLUS Drum Brake Foundation Kit, Includes Key No. 2 Left Hand, Part No. QP4-1656-2729 Right Hand, Part No. QP4-1656-2730	1 1
2		*Dust Shield	2
3	80345-004	3/4"-16 x 2 1/4" Low Profile Hex Head Bolt	14
4	22962-001	3/4" Flat Washer	20
5	80691-001	3/4"-16 UNC - 2B Nut	6
6		*Conmet Preset Plus FL Hub Assembly Part No. 10081313, Includes Key Nos.6-16 *Hub Part No. 10033316 *Conmet Hub Bearing Rebuild Kit No. 10081728, One Wheel End, Includes Key Nos. 6-11 *Conmet Wheel Seal Kit No. 10081519, One Wheel End, Includes Key Nos. 6-7	2
7		*Bearing Spacer Part No. 10034342	
8		*Wheel Seal Part No. 10045883	

KEY NO.	PART NO.	DESCRIPTION	VEHICLE QTY.
9		*Inner Bearing Cone Part No. 10041922	
10		*Inner Bearing Cup Part No. 10041921	
11		*Outer Bearing Cup Part No. 10041923	
12		*Outer Bearing Cone Part No. 10041924 *Conmet Preset Plus FL Nut Assembly Kit No. 10036550, Includes Key Nos. 13-16	
13		*Snap Ring - Double Wind Part No. 10033288	
14		*Spindle Nut Lockwasher 10031171	
15		*Outer Spindle Nut Part No. 10031170	
16		*Snap Ring Retainer Part No. 10031172	
17		**Drum	
18		M22 Flange Nut	20
19		*Drivparts Hub Cap Gasket No. G-3009	2
20		*Drivparts Hub Cap No. 343-009, Includes Key No. 21	2
21		*Rubber Plug	2
22	64545-002	5/16"-18 UNC x 3/4" Hex Bolt with Retained Washer	12

NOTES: * These components are installed by Hendrickson for new production assembly but not supplied by Hendrickson for aftermarket service purposes. Description and part number listed for reference only. For more information and assistance with service, maintenance and rebuild instructions on these components see below component manufacturers:

- **ConMet** 800.547.9473 or www.conmet.com
- **DRiV Incorporated** 800-325-8886 or www.drivparts.com
- **Meritor** 888.725.9355, or www.meritorpartsexpress.com (parts), www.meritorbullpen.com (technical support)
- **WABCO-ZF Friedrichshafen** 855.228.3203 or www.wabco-customercentre.com

** Not supplied by Hendrickson, used for reference only. Contact the vehicle manufacturer for more information.



27.5K lb Capacity per Axle

Single Steer • 7.2" Ride Height

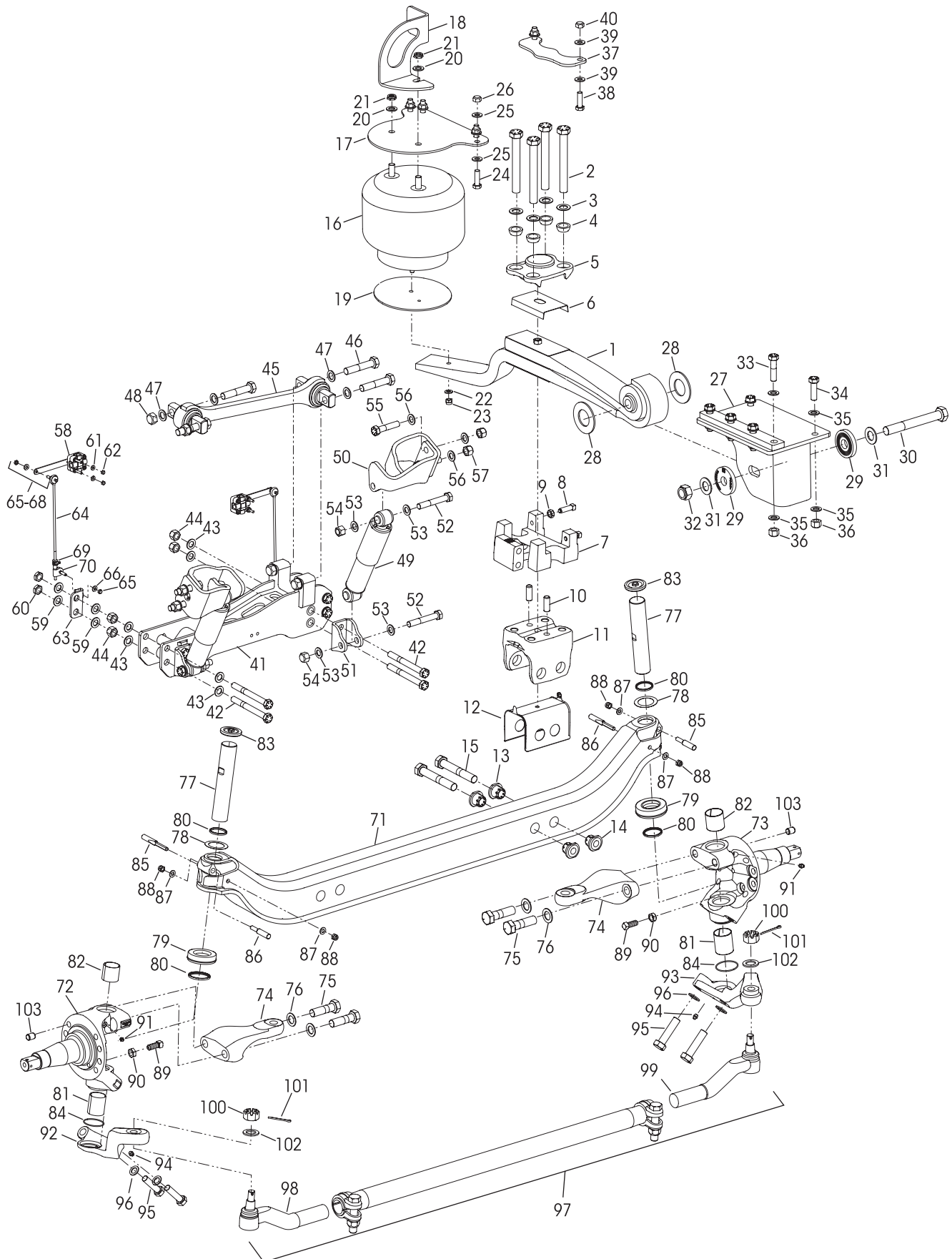



AIRTEK® NXT System for Engine & Accessory Manufacturing Inc. (EAM) Vehicles

KEY NO.	PART NO.	DESCRIPTION	VEHICLE QTY.
		Leaf Spring & Clamp Group Assembly, Includes Key Nos. 1-15	
	80002-201	Left Hand	1
	80002-202	Right Hand	1
1		Leaf Spring Assembly	
	82417-000	Right Hand	1
	82418-000	Left Hand	1
	34013-419	Clamp Group Fastener Service Kit, One Wheel End, Includes Key Nos 2-4, 6	
2		*1"-8 UNC x 8" Hex Bolt	8
3		*1" Flat Washer	8
4		*1" Spherical Washer	8
5	78888-000	Top Pad with Jounce Stop	2
6	79273-001	Leaf Spring Liner	2
7		Bottom Cap	
	80379-301	Left Hand	1
	80379-302	Right Hand	1
8	80483-001	5/8" x 2" Set Screw	4
9	17491-023	5/8"-11 UNC Jam Nut	4
10	18831-021	Dowel Pin	4
11	91799-000	Axle Seat	2
	34013-512	Axle Collar Service Kit, One Side, Includes Key Nos. 12-15	
12	78887-002	Axle Seat Liner	2
		*Axle Collar	
13		Non Threaded, Bolt Side	4
14		Threaded, Tie Rod Side	4
15		*1"-8 UNC x 6 1/2" Hex Bolt	4
16	91125-001	Air Spring Assembly	2
17	91797-100	Upper Air Spring Plate	2
18	91797-113	Upper Air Spring Z-Bracket	2
19	94338-100	Lower Air Spring Spacer	2
	91855-029	Air Spring Fastener Service Kit, One Side, Includes Key Nos.20-23	
20		*3/4" Upper Air Spring Flat Washer	4
21		*3/4"-16 UNF Upper Air Spring Locknut	4
22		*1/2" Lower Air Spring Hardened Washer	2
23		*1/2"-13 UNC Lower Air Spring Locknut	2
	49177-072	Air Spring Frame Mounting Fastener Kit, One Side, Includes Key Nos. 24-26	
24		*5/8"-11 UNC x 2" Hex Screw	8
25		*9/8" Flat Washer	16
26		*5/8"-11 UNC Nut	8
27		Frame Hanger	
	79819-101	Left Hand	1
	79819-102	Right Hand	1
	60632-048	QUIK-ALIGN Collar Service Kit, One Wheel End, Includes Key Nos. 28-32	
28		*Wear Pad	4
29		*QUIK-ALIGN Concentric Collar	4
30		*1 1/8" x 12 UNF x 9" Hex Bolt	2
31		*1 1/8" Hardened Washer	4
32		*1 1/8" x 12 UNF Locknut	2
	64105-017	Frame Hanger Mounting Fastener Kit, Axle Set Includes Key Nos. 33-36	
33		*3/4"-10 UNC x 3" Hex Bolt	8
34		*3/4"-10 UNC x 2 1/2" Hex Bolt	4
35		*3/4" Flat Washer	24
36		*3/4"-10 UNC Nut	12
37	94933-010	Jounce Stop, Front Left Hand & Right Hand	2
	49399-003	Jounce Stop Frame Mounting Fastener Kit, One side, Includes Key Nos. 38-40	
38		*5/8"-11 UNC x 2" Hex Screw	4
39		*9/8" Flat Washer	8
40		*5/8"-11 UNC Nut	4

KEY NO.	PART NO.	DESCRIPTION	VEHICLE QTY.
41	91796-001	Axle /TVTR Bracket	1
	58819-021	Axle /TVTR Bracket Fastener Kit, Axle Set, Includes Key Nos.42-44	
42		3/4"-10 UNC x 7" Hex Bolt	8
43		3/4" Flat Washer	12
44		3/4"-10 UNC Locknut	8
45	8232-0000-550	TRAAAX ROD Torque Rod Assembly	1
	58821-051	Torque Rod Fastener Service Kit, One Side, Includes Key Nos.46-48	
46		7/8"-14 UNF x 4 1/2" Hex Bolt	4
47		7/8" Flat Washer	8
48		7/8"-14 UNF Locknut	4
49	77538-003	Shock Absorber	2
50	95133-000	Upper Shock Bracket	2
51	91795-001	Lower Shock Bracket	2
	50754-091	Shock Absorber Fastener Kit, One Axle, Includes Key Nos. 52-54	
52		*3/4"-10 UNC x 4 3/4" Hex Bolt	4
53		*3/4" Flat Washer	8
54		*3/4"-10 UNC Locknut	4
	50754-093	Shock Bracket Frame Mounting Fastener Kit, One Side, Includes Key Nos. 55-57	
55		*3/4"-10 x 3 1/2" Hex Head Cap Screw	4
56		*3/4" Flat Washer	8
57		*3/4"-10 UNC-2b Nut	4
	91855-016	Height Control Valve Service Kit, Includes Key Nos. 58-64	
58	60841-100	Height Control Valve Assembly	2
59		*3/4" Flat Washer	8
60		*3/4"-10 UNC Jam Nut	4
61		*1/4" Flat Washer	4
62		*1/4"-20 UNC Nut	4
63	91795-013	Lower Linkage Bracket	2
64		HCV Linkage Assembly, Includes Key Nos. 65-70	
	58994-059	Right Hand	1
	58994-058	Left Hand	1
	75841-003	HCV Frame Mounting Fastener Kit, Includes Key Nos. 65-67	
65		*5/16"-18 UNC Locknut	4
66		*5/16" Flat Hardened Washer	4
67		*5/16"-18 UNC Jam Nut	4
68		*5/16"-18 UNC Stud	4
69		*Valve Arm Clamp	2
70		*Adjustable Valve Arm Joint	2
71	79634-001	Axle	1
		Knuckle Assembly, Includes Key Nos. 81, 84, 89-91, 103	
72	77243-001	Left Hand	1
73	77243-002	Right Hand	1
74	79685-006	Steering Arm	2
75	30550-040	1"-14 UNF x 3 1/4" Hex Bolt	4
76	22962-051	1" Flat Washer	4
	34013-230	Kingpin Service Kit, One Side Includes Key Nos. 77-88, 95-96	
77		*Kingpin	2
78		Kingpin Shim (As needed for service)	2
a	77241-002	0.01" Thickness	
b	77241-003	0.02"	
79	75918-001	Thrust Bearing	2
80	75966-001	Kingpin Seal	4
		Kingpin Bushing	
81	75919-001	Lower	2
82	75919-002	Upper	2
83	77209-001	Grease Cap	2
84	68303-004	O-Ring	2



KEY NO.	PART NO.	DESCRIPTION	VEHICLE QTY.
		Kingpin Draw Key	
85	75925-001	Upper, 3 $\frac{3}{8}$ " Length	2
86	75925-002	Lower, 4 $\frac{3}{4}$ " Length	2
87	22962-054	$\frac{7}{16}$ " Flat Washer	4
88	17700-008	$\frac{7}{16}$ "-14 UNC-2B Locknut	4
89	93334-001	$\frac{5}{8}$ "-11 UNC x 1 $\frac{1}{2}$ " Stop Bolt	2
90	17491-023	$\frac{5}{8}$ "-11 UNC-2B Jam Nut	2
91	33117-000	Grease Zerk	2
		Tie Rod Arm Assembly, Includes Key No. 94	
92	77244-077	Left Hand	1
93	77244-078	Right Hand	1
94	33117-000	Grease Zerk	2
95	30418-015	$\frac{7}{8}$ "-14 UNF x 3 $\frac{1}{4}$ " Hex Bolt	4
96	22962-002	$\frac{7}{8}$ " Flat Washer	4

KEY NO.	PART NO.	DESCRIPTION	VEHICLE QTY.
97	79365-002	Tie Rod Assembly, Heavy-duty, Drop Includes Key Nos. 98-100	1
		Tie Rod End Service Kits,	
	60961-884	Axle Set, Includes Kit Nos. 60961-882 and -883	
	60961-882	Left Hand, Includes Key Nos. 98, 100-101	
	60961-883	Right Hand, Includes Key Nos. 99-101	
		*Tie Rod End, Includes Key No. 100	
98		Left Hand	1
99		Right Hand	1
100		* $\frac{7}{8}$ "-14 UNF-2A Castle Nut	2
101		*Cotter Pin	2
102		* $\frac{7}{8}$ " Flat Washer	2
103	64246-000	ABS Sensor Sleeve	2

NOTES: Quantities specified are shown for a single steer axle system, service kit components may vary from amount shown in lists.

* Item included in kit/assembly only, part not sold separately.



SECTION 6 Towing Procedures

Please read, understand, and comply with the vehicle towing instructions and safety precautions provided by the vehicle manufacturer. Hendrickson recommends that in addition, vehicles equipped with AIRTEK NXT steer axle and integrated suspension system for Engine & Accessory Manufacturing (EAM) vehicles also comply with off-roadway towing safety warning below.

OFF-ROADWAY TOWING



WHEN A VEHICLE IS DISABLED AND EQUIPPED WITH A AIRTEK NXT SYSTEM, CARE MUST BE TAKEN TO ENSURE THERE IS NO DAMAGE TO THE SUSPENSION OR AXLE WHEN TOWING THE VEHICLE. THE USE OF TOW STRAPS ARE NECESSARY TO TOW A DISABLED VEHICLE FROM A REPAIR FACILITY PARKING LOT INTO THE SHOP BAY. THE TOW STRAPS SHOULD BE CONNECTED TO THE TOW HOOKS PROVIDED BY THE VEHICLE MANUFACTURER AT THE FRONT OF THE BUMPER. IF THE USE OF TOW HOOKS IS NOT AN OPTION, THEN TOW STRAPS MAY BE WRAPPED AROUND THE FRONT AIRTEK NXT SYSTEM, (SEE FIGURE 6-1) IN A MANNER THAT IS ACCEPTABLE FOR TOWING THE VEHICLE FROM A REPAIR FACILITY PARKING LOT INTO THE SHOP BAY. DO NOT USE A TOW CHAIN AROUND THE FRONT AIRTEK NXT SYSTEM TO TOW THE VEHICLE, DOING SO WILL DAMAGE THE AXLE AND VOID ANY APPLICABLE WARRANTY, (SEE FIGURE 6-1).

- NYLON STRAPS OR CHAINS ARE NOT RECOMMENDED FOR ON-HIGHWAY OR ON-ROADWAY TOWING.

FIGURE 6-1

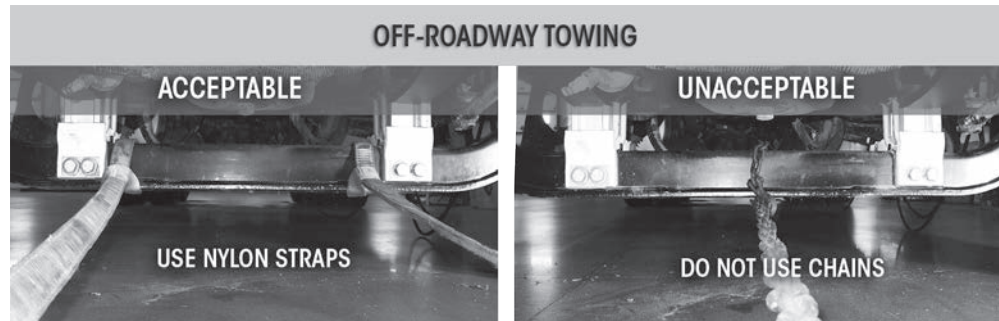



SECTION 7

Preventive Maintenance

Following appropriate inspection procedures is important to help ensure the proper maintenance and operation of the AIRTEK NXT integrated front air suspension with STEERTEK NXT high-capacity steer axle system and components function to their highest efficiency.

HENDRICKSON RECOMMENDED INSPECTION INTERVALS	PRE-DELIVERY	FIRST IN-SERVICE	PREVENTIVE MAINTENANCE	
		within the first 100 miles (160 km), 10 hours	1,000 miles (1,600 km), 100 hours or whichever comes first	5,000 miles (8,000 km), every 6 months or whichever comes first

Hendrickson recommends to visually inspect for proper assembly, function, overall condition, and any signs of damage. During the inspection intervals as shown, check for any unusual movement, loose or missing components, abrasive or adverse contact with other parts, damaged or cracked parts, and improper suspension function or alignment. Replace components as necessary.

Air Spring and Air Supply (Pneumatic Components)	■	■	■	
Axle Collar Through Bolts	■	■	■	
Axle Seat and Axle Seat Liner	■	■	■	
Clamp Group	■	■		■
Fasteners	■	■		■
Frame Hanger Assembly	■	■	■	
Lateral Alignment	■	■		■
Leaf Spring Assembly	■	■	■	
QUIK-ALIGN Pivot Connection	■	■		■
Ride Height	■	■		■
Steering Operation	■		■	
STEERTEK NXT High-Capacity Axle and Tie Rod Assembly	■	■	■	
Shock Absorber	■		■	
Tire Wear			■	
Torque Rod	■	■	■	
Wear and Damage			■	

Refer to the vehicle manufacturer's applicable publications for other preventive maintenance requirements.

COMPONENT INSPECTION

- **Air spring** — Look for chafing or any signs of spring or component damage. Replace all worn or damaged parts.
- **Air supply (Pneumatic components)** — The air supply to the system plays a large role in the air springs' performance. Inspect, clean and replace, if necessary, any support products to the air springs, valves, regulators and air lines. See Air Fitting Inspection in this section if an air leak is suspected.
- **Axle collar through bolts** — Visually inspect at preparation of delivery and check torque within the first 1,000 miles and regular preventive maintenance intervals.



- **Axle seat and axle seat liner** — Inspect axle seats for any cracks or damage. Inspect axle seat liners, check for any missing liner material. If liner material is missing disassemble clamp group and replace liners, see Component Replacement section of this publication.
- **Clamp group** — Visually inspect for any loose or damaged fasteners. Verify the clamp group is properly aligned and fasteners have the proper torque values maintained.
- **Fasteners** — Visually inspect for any loose or damaged fasteners on the entire suspension. Make sure all fasteners are tightened to the specified torque. Refer to the  Torque Specifications section of this publication. Use a calibrated torque wrench to check torque in a tightening direction. As soon as the fastener starts to move, record the torque. Correct the torque if necessary. Replace any worn or damaged fasteners.

NOTE

Torque values shown in this publication apply only if Hendrickson supplied fasteners are used. If non-Hendrickson fasteners are used, follow the torque specifications listed in the vehicle manufacturer's service manual.

- **Frame hanger assembly** — Inspect the frame hanger for any signs of weld cracking or damage. Refer to the vehicle manufacturer for repair or replacement.
- **Lateral alignment** — Verify the lateral alignment of the drive axles are within the vehicle manufacturer's tolerances.
- **Leaf spring assembly** — Look for any cracks. Replace if cracked or broken. Check front bushings for any wear or deterioration. See Component Replacement section of this publication for replacement procedure.
- **QUIK-ALIGN Pivot Connection** — Visually inspect the connection for signs of looseness or movement. Visually inspect the bushing for wear. Verify the connections have the proper torque values maintained. See the Torque Specifications section of this publication for recommended torque requirements.
- **Ride height** — Verify the ride height, refer to the Alignment & Adjustments section of this publication.
- **Steering operation** — All steering components must move freely through the full range of motion from axle stop to axle stop. Check for looseness at all pivot points. Inspect and lubricate all pivot points. Refer to the Troubleshooting Guide section of this publication.
- **STERTEK NXT High-capacity axle and tie rod assembly** — Visually inspect for any cracks or dents on the axle, refer to Tie Rod Ends in this section. Replace as necessary.
- **Shock absorber** — Look for any signs of dents or leakage, misting is not considered a leak. See Shock Absorber Inspection in this section.
- **Tire wear** — Inspect tires for any wear patterns that may indicate suspension damage or misalignment. See Tire Inspection in this section.
- **Torque rod** — All torque rods must be inspected for looseness, torn or shredded rubber, and proper fastener torque. If there is metal-to-metal contact in the bushing joint, this is a sign of excessive bushing wear and the torque rod needs to be serviced, see the TRAAX ROD Transverse Torque Rod inspection in this section.
- **Wear and damage** — Inspect all parts of suspension for any wear and damage. Look for bent or cracked parts. Replace all worn or damaged parts.



LUBRICATION INTERVALS

For vehicles equipped with the STEERTEK NXT high-capacity steer axle system, regular lubrication intervals should be followed to help prevent premature wear to the kingpin bushings and tie rod ends, see lubrication chart below.

NOTE The recommended service lubrication interval is a guideline, the vehicle may require increased lubrication interval depending on severity of operation.

STEERTEK NXT High-capacity Greasing and Lubrication Specifications			
Component	Greasing Interval	Grease	Outside Temperature
Kingpin Bushings	Maximum of 5,000 miles (8,000 kilometers) or 6 months, whichever comes first.	Multipurpose NLGI #2 EP, rated GC-LB or equivalent	Refer to the lubricant manufacturer's specifications for the temperature service limits applicable to your area.
Tie Rod Ends			
Threaded Pin	Every 3 months	Lithium Base	
Drag Link	Refer to the Vehicle Manufacturer		
Wheel End Hub Bearings and Seals	Refer to the Vehicle Manufacturer for lubricant type and other recommendations. For compatible lubricants, intervals and the appropriate quantity to use, consult the Wheel end Component Manufacturers listed in the Parts List section of this publication.		

KINGPIN LUBRICATION

1. Place vehicle on the ground.
2. Chock the wheels and set parking brake.
3. Prior to greasing the kingpins on the vehicle, the suspension must be in a loaded condition.
4. Clean off all the grease zerks and grease gun tip with a clean shop towel prior to lubrication, see Figures 7-1 to 7-3.
5. Lubricate the kingpins through the grease zerks on the top and bottom of the steering knuckle, see Lubrication Specification chart above.
6. Force the required lubricant into the upper and lower kingpin grease zerks, until new lubricant flows out from the upper kingpin connection and steering knuckle and the thrust bearing purge location, see Figures 7-1 to 7-3.
7. Remove wheel chocks.

NOTE Greasing at the lower zerk should purge grease from the thrust bearing shell. The left and right side of the STEERTEK NXT high-capacity steer axle system have steel roller thrust bearings.

FIGURE 7-1



FIGURE 7-2

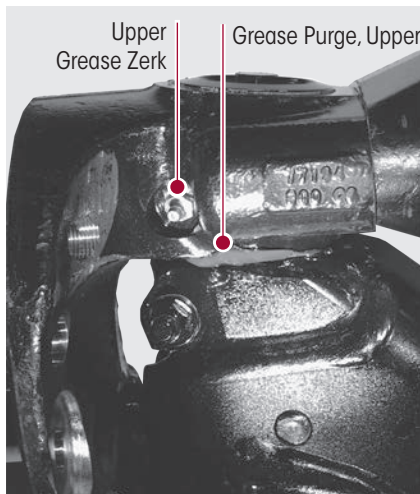
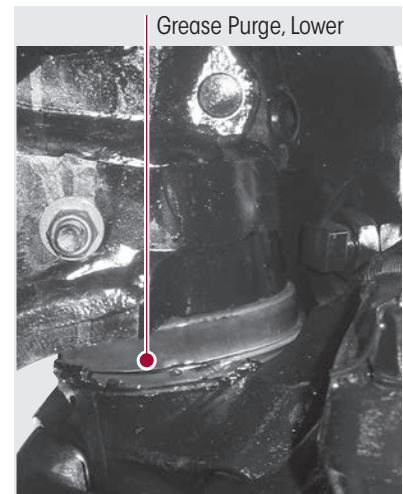

FIGURE 7-3





TIE ROD ENDS

INSPECTION

Prior to inspection the entire system must be unloaded (i.e., the front end of the vehicle must be raised and supported with safety stands).



DO NOT GREASE THE TIE ROD ASSEMBLY BEFORE PERFORMING THE INSPECTION. DOING SO CAN INHIBIT EFFORTS TO DETERMINE ACTUAL WEAR.



REPLACE THE ENTIRE TIE ROD END IF THE BOOT IS TORN OR MISSING, FAILURE TO DO SO CAN CAUSE PREMATURE WEAR OF THE TIE ROD END.

1. Chock the rear wheels of the vehicle.
2. Use the bottom of the axle beam or the frame rails to raise the front end of the vehicle off the ground and support with safety stands.
3. With the engine turned off, turn the wheels from full left to full right and then return to the straight-ahead position.
4. Check that the boots are in place and completely installed over the tie rod ends.
5. Check for cracking or tears in the boots. Also check the boot seals for damage. Replace the entire tie rod end if the boot is damaged.



THE COTTER PIN MUST BE INSTALLED CORRECTLY THROUGH THE TIE ROD END WITH THE CASTLE NUT TIGHTENED TO THE PROPER TORQUE SPECIFICATION IN ORDER TO SECURELY ATTACH THE TIE ROD. LOSS OF THE COTTER PIN CAN CAUSE THE TIE ROD END NUT TO BECOME LOOSE AND ADVERSELY AFFECT VEHICLE STEERING AND POSSIBLY RESULT IN TOTAL LOSS OF STEERING CONTROL.

6. Check that the tie rod end nut is installed and secured with a cotter pin. If the cotter pin is missing, check the nut torque specification and then install a new cotter pin. Always tighten the castle nut to specified torque when setting the cotter pin. **DO NOT** back off the nut to insert cotter pin.



IT IS CRITICAL TO CHECK THE 3/4" TIE ROD CLAMP BOLT HEAD LOCATION TO VERIFY THE CLAMP FASTENERS HAVE SUFFICIENT CLEARANCE AWAY FROM THE LOWER SHOCK MOUNT AT FULL WHEEL CUT. THE FASTENERS MUST NOT CONTACT THE LOWER SHOCK MOUNT. FAILURE TO DO SO CAN CAUSE ONE OR MORE COMPONENTS TO FAIL CAUSING LOSS OF VEHICLE CONTROL AND POSSIBLE PERSONAL INJURY OR PROPERTY DAMAGE.

7. Verify the 3/4" tie rod clamp bolt head does not contact the lower shock mount at full wheel cut, see Figure 7-4.



THE THREADED PORTION OF THE TIE ROD END MUST EXTEND PAST THE SLOTS INTO THE TIE ROD CROSS TUBE, SEE FIGURE 7-4. FAILURE TO DO SO CAN CAUSE COMPONENT DAMAGE, LOSS OF VEHICLE CONTROL AND POSSIBLE PERSONAL INJURY OR PROPERTY DAMAGE.

8. Check that the tie rod end is threaded correctly into the cross tube and is engaged deeper than the end of the cross tube slot. The tie rod end must be visible the entire length of the cross tube slot, see Figure 7-4.

FIGURE 7-4

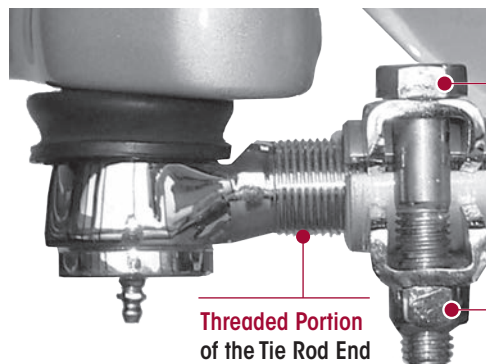

3/4" Tie Rod Clamp Bolt

It is critical to check the 3/4" tie rod clamp bolt head location to verify the clamp fasteners have sufficient clearance away from the lower shock mount at full wheel cut. The fasteners must not contact the lower shock mount.

Tie Rod Cross Tube Slots

It is critical to have the threaded portion of the tie rod end extend past the slots in the tie rod cross tube.

3/4" Tie Rod Clamp Locknut

Tightening Torque
68 ± 7 ft-lb (92 ± 9 Nm)

CAUTION

9. Check that grease zerks are installed. Replace a damaged grease zerk with a new one.

DO NOT USE THE FOLLOWING ITEMS OR METHODS TO CHECK FOR MOVEMENT OF THE TIE ROD ASSEMBLY, WHICH CAN CAUSE DAMAGE TO COMPONENTS:

- A CROW BAR, PICKLE FORK, OR 2 X 4.
- ANYTHING OTHER THAN HANDS USED TO GRASP AND ROTATE THE CROSS TUBE ASSEMBLY (CAN RESULT IN DAMAGE TO THE CROSS TUBE).
- EXCESSIVE PRESSURE OR FORCE APPLIED TO THE TIE ROD ENDS OR THE JOINTS OF THE ASSEMBLY.

10. By hand or using a pipe wrench, with jaw protectors to avoid gouging the cross tube, rotate the cross tube toward the front of the vehicle and then toward the rear. After rotating, center the cross tube. If the cross tube will not rotate in either direction, replace both tie rod ends, see Figure 7-5.

11. Position yourself directly below the tie rod end. Using both hands, grab the assembly end as close to the tie rod end as possible (no more than 6" or 152.4 mm). Apply hand pressure with reasonable human effort vertically up and down in a push-pull motion several times (using approximately 50-100 pounds of force). Check for any movement or looseness at both tie rod end locations, see Figure 7-6.

FIGURE 7-5

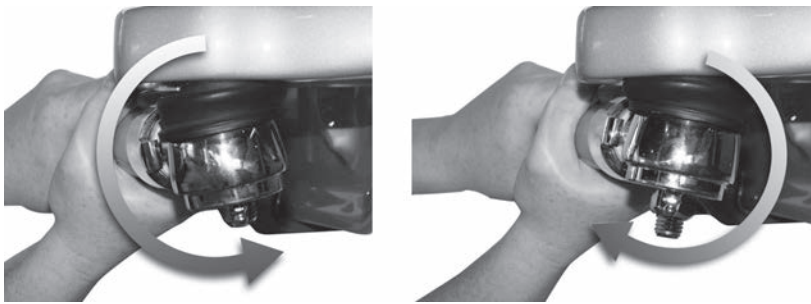
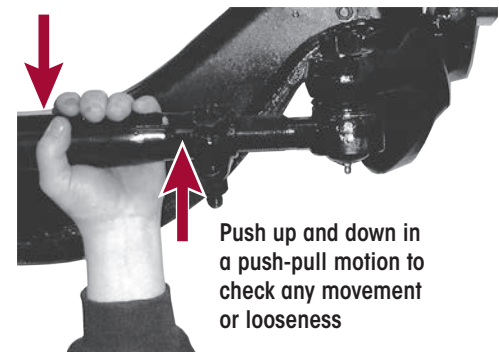

FIGURE 7-6



12. If there is any movement in the tie rod assembly, install a magnetic based dial indicator on the tie rod arm, see Figure 7-7.

13. Set the dial indicator to zero.

14. Apply hand pressure with reasonable human effort vertically up and down in a push-pull motion several times (using approximately 50-100 pounds of force). Observe the reading on the dial indicator.

15. If the reading is more than 0.060", replace both tie rod ends at the next service interval.

16. If a tie rod end exhibits ≥ 0.125 " of movement by hand, the vehicle should be removed immediately from use and the tie rod end be replaced.

FIGURE 7-7

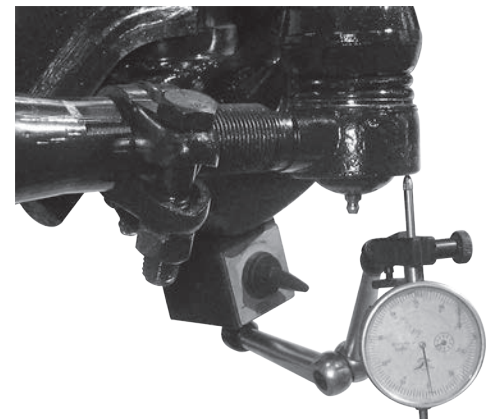
NOTE

According to the Commercial Vehicle Safety Alliance (CVSA), the "out of service" criteria for front steer axle tie rod assemblies on any commercial vehicle is: Any motion other than rotational between any linkage member and its attachment point of more than $\frac{1}{8}$ " (3 mm) measured with hand pressure only. (393.209(d)), (published in the North American Standard Out-of-Service Criteria Handbook, 2025.)

LUBRICATION PROCEDURE

1. Turn the vehicle wheels straight ahead and chock rear wheels.
2. Wipe the grease zerk and grease gun tip with clean shop towels.
3. Wipe the seal/boot clean with shop towels.



CAUTION

4. Attach a grease gun to the grease zerk. Either a hand or pneumatic grease gun is acceptable. If air operated grease gun is used, system air pressure should not exceed 150 psi (1035 kPa).

EXCEEDING THE MAXIMUM AIR PRESSURE TO THE GREASE ZERK CAN CAUSE DAMAGE TO THE DUST BOOT AND COMPONENT FAILURE.

5. Dirt, water, and discolored old grease should flow from the relief vents or purge holes near the boot crimp or bellows area, see Figure 7-8. Continue to purge grease until fresh grease flows from the purge area.
6. If the tie rod end is designed for lube service and it will not accept grease proceed as follows:
 - a. Remove the grease zerk
 - b. Inspect the threaded grease zerk hole in the tie rod end and remove any obstructions
 - c. Install a new grease zerk
 - d. Continue the lubrication procedure
 - e. If the tie rod end will not accept grease following this procedure it will be necessary to replace the tie rod end, (see Tie Rod Ends and Cross Tube replacement in the Component Replacement section of this publication)
7. Apply grease until all the old grease is purged from the boot and fresh grease is coming out.

FIGURE 7-8

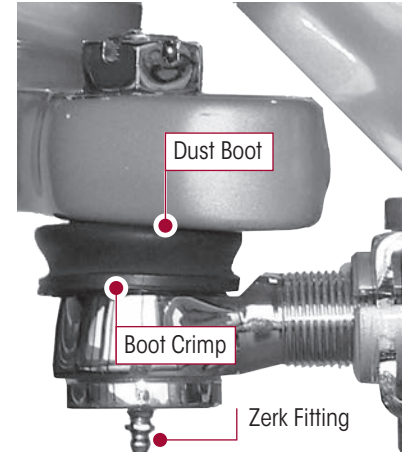

CLAMP GROUP RETORQUE INTERVALS

WARNING

ENSURE THE CLAMP GROUP IS ALIGNED PROPERLY PRIOR TO TIGHTENING HARDWARE. FAILURE TO DO SO CAN CAUSE LOSS OF VEHICLE CONTROL, PROPERTY DAMAGE, OR PERSONAL INJURY.

1. Clamp group hex bolts and axle collar hex cap bolts must be:
 - Tighten to torque specification at preparation for delivery,
 - Plus be re-torqued at 1,000 miles,
 - Thereafter follow the 12 month / 10,000 mile visual inspection and annual retorque interval.
2. Ensure that the clamp group is properly aligned and the hex bolts are seated in the top pad and the bottom cap, and centered on the leaf spring assembly, see Figure 7-9.
3. Check for signs of component or bolt movement.
4. If signs of movement are present, disassemble the clamp group fasteners, check for component wear or damage and replace components as necessary, then install new clamp group fasteners. Follow assembly instructions per Component Replacement section of this publication.
5. Tighten the 1" clamp group hex bolts evenly in 200 foot pound increments to 600 ± 60 foot pounds torque in the proper pattern to achieve uniform bolt tension, see Figure 7-10.

FIGURE 7-9

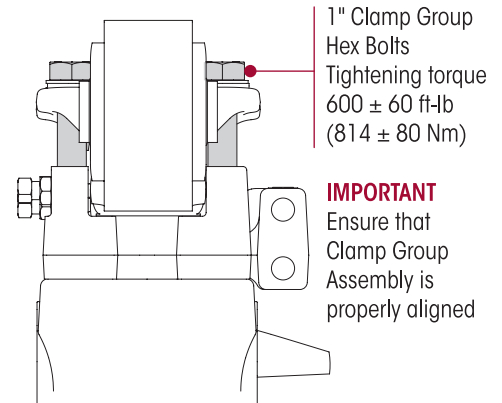
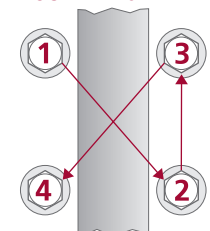

FIGURE 7-10



AXLE COLLAR THROUGH BOLTS

WARNING

LOOSE OR OVER TORQUED FASTENERS CAN CAUSE COMPONENT DAMAGE, LOSS OF VEHICLE CONTROL, PROPERTY DAMAGE, OR SEVERE PERSONAL INJURY. MAINTAIN CORRECT TORQUE VALUES AT ALL TIMES. CHECK TORQUE VALUES ON A REGULAR BASIS AS SPECIFIED.

NOTE

A popping noise coming from the steer axle area may indicate loose fasteners. Proceed to the next service facility for a torque inspection to ensure fasteners are tightened to specification.

Axle collar fasteners must be tightened to specified torque at:

- Preparation for delivery, retorqued at 1,000 miles, thereafter follow the 6 month / 5,000 mile visual inspection and annual retorquing interval.

TORQUE INSPECTION

1. Chock the wheels.
2. Tighten the axle collar fasteners at the bolt head evenly in 200 foot pound increments to 800 ± 20 foot pounds torque, see Figures 7-11 and 7-12.
3. To identify the torque inspection is completed, apply a mark with torque seal to both the axle collars and the bolt heads.
4. Remove the wheel chocks.

FIGURE 7-11

1" x 6½" Hex Thru Bolt
Tightening Torque
800 ± 20 ft-lb
(1084 ± 27 Nm)

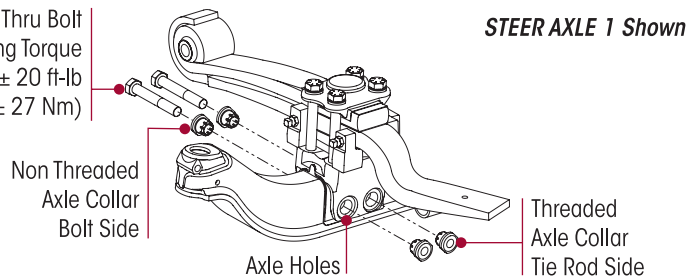
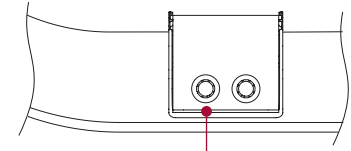

FIGURE 7-12



1" Axle Collar at the Bolt Head
Tightening Torque
800 ± 20 ft-lb (1084 ± 27 Nm)

AXLE SEAT LINER

NOTE

Axle seat liners are installed to help prevent any type of abrasion on the axle at the clamp group area. Any time an axle seat is removed it is mandatory that the axle seat liner be replaced.

INSPECTION

Liner Crack Criteria — It is possible for the axle seat liner to crack during service. If the liner is cracked and all the pieces are intact it is not necessary to replace the liner. If the liner is broken out and there are pieces missing the liner must be replaced immediately, refer to the leaf spring and Clamp Group Assembly in the Component Replacement section of this publication.

QUIK-ALIGN CONNECTION

VISUAL INSPECTION

1. Chock the wheels of the vehicle and apply the parking brakes.
2. Verify the axle assembly is lowered with the parking brake set and the tires on the ground.
3. Inspect the frame hanger and QUIK-ALIGN connection (see Figure 7-13) for the following:
 - Cracks and damage
 - Loose fasteners, and frame hanger or leaf spring movement
 - Visually inspect the QUIK-ALIGN connection for any movement
 - Ensure the QUIK-ALIGN collars are flush against the frame hanger, if the QUIK-ALIGN collars show signs of movement, replacement is necessary.



4. If signs of movement are present, disassemble the QUIK-ALIGN fasteners, check for component wear or damage and replace components as necessary, then install new QUIK-ALIGN fasteners. Follow assembly instructions per Component Replacement section of this publication.
5. Tighten the 1" QUIK-ALIGN fasteners to $\approx 850 \pm 20$ foot pounds torque, see Figure 7-13.
6. Release the parking brakes and remove the wheel chocks.

FIGURE 7-13

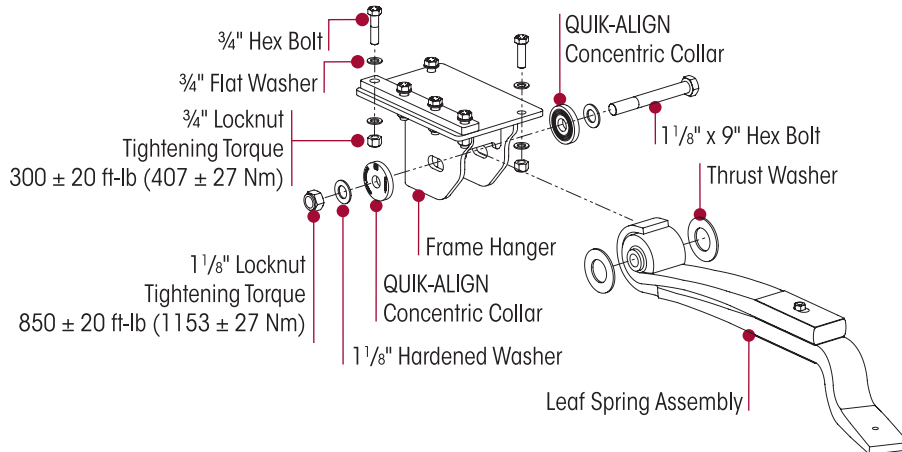

KINGPIN BUSHING WEAR

CHECKING STEERING KNUCKLE LATERAL MOVEMENT

NOTE

If one (1) bushing is worn or damaged, it is mandatory to replace both the upper and lower bushings on that knuckle assembly.

1. Chock the wheels to help prevent the vehicle from moving.
2. Set the parking brakes.
3. Use a jack to raise the vehicle until the wheels are off the ground. Support the vehicle with safety stands.
4. **CHECKING THE UPPER KINGPIN BUSHING.** Install the magnetic dial indicator base onto the axle and place the tip against the steering knuckle, see Figure 7-14.
5. Set the dial indicator to "0" zero.
6. Move the top and the bottom of the tire in and out by applying reasonable constant pressure and then release, see Figure 7-16.

FIGURE 7-14
Check **UPPER** Kingpin Bushing

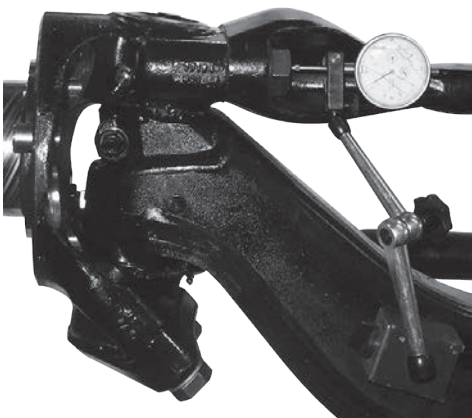

FIGURE 7-15
Check **LOWER** Kingpin Bushing

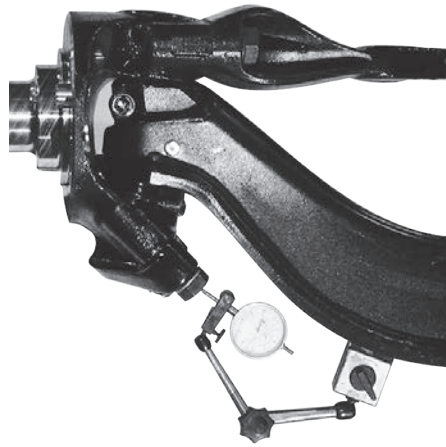

FIGURE 7-16
Move **TOP and BOTTOM** of the tire in and out



7. Check the reading on the dial indicator. If the dial indicator moves more than 0.015", the upper bushing is worn or damaged. Replace both bushings. Refer to the Kingpin Bushing replacement procedure in the Component Replacement section of this publication.
8. **CHECKING THE LOWER KINGPIN BUSHING.** Install a magnetic dial indicator base on the axle and the indicator tip is against the inside of the bottom of the knuckle, see Figure 7-15.
9. Set the dial indicator to "0" zero.
10. Move the bottom of the tire in and out. If the dial indicator moves more than 0.015", the lower bushing is worn or damaged. Replace both kingpin bushings. Refer to the Component Replacement section of this publication.
11. Lower the vehicle and remove the wheel chocks.

STEERING KNUCKLE

CHECKING VERTICAL END PLAY (UP AND DOWN MOVEMENT)

The operating specification for vertical end play on the steering knuckle is 0.008" to 0.030".

FIGURE 7-17

Ensure the tip of the dial indicator is on the top of the upper steering knuckle (not on the grease cap)

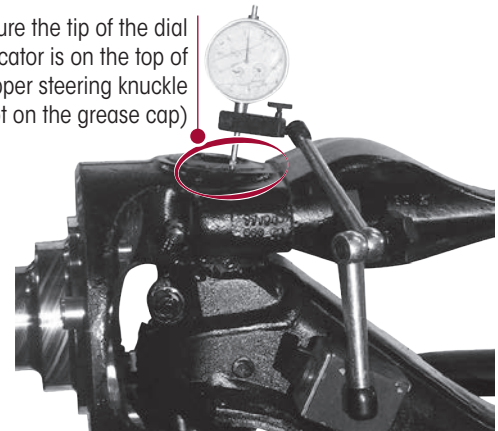

1. Chock the rear tires to help prevent the vehicle from moving.
2. Set the parking brakes.
3. Use a jack to raise the vehicle until both tires are 1" off the ground.
4. Loosen the kingpin draw keys.
5. Place a dial indicator on each side of the axle as follows:
 - a. Index the wheels slightly (left or right).
 - b. Place the magnetic dial indicator base on the axle, see Figure 7-17.
 - c. Place the tip of the dial indicator on the top of the upper steering knuckle.
6. Set the dial indicator to "0" (zero).
7. Lower the jack.
8. Record dial indicator reading.
 - If the steering knuckle binds or **zero** end play is measured, remove shims from the shim pack.
 - If the reading is more than the correct specification shown in Table 7-1, add shims to the shim pack.
9. Perform a re-torque on the kingpin draw key nylock-nuts to  35 ± 5 foot pounds torque.
10. Lower the vehicle and remove the wheel chocks.

TABLE 7-1

VERICAL END PLAY SPECIFICATIONS	
New or Rebuilt Axles	0.001"-0.010" (0.025-0.254 mm)
In-service Axles	0.001"-0.030" (0.025-0.762 mm)



SHOCK ABSORBER

NOTE

It is not necessary to replace shock absorbers in pairs if only one (1) shock absorber requires replacement.

Hendrickson uses a long service life, premium shock absorber on all AIRTEK NXT suspensions. When the shock absorber replacement is necessary, Hendrickson recommends that the shock absorbers be replaced with identical Hendrickson Genuine parts for servicing. Failure to do so will affect the suspension performance, durability, and will void any applicable warranty. See vehicle manufacturer's applicable publications for other shock absorber inspection requirements.

Inspection of the shock absorber can be performed by doing a heat test, and a visual inspection. Replace as necessary, refer to the Component Replacement section in this publication.

HEAT TEST AND PHYSICAL INSPECTION

1. **Heat Test:** Drive the vehicle at moderate speeds on a rough road for minimum of fifteen minutes.



WARNING

DO NOT GRAB THE SHOCK ABSORBER AS IT COULD POSSIBLY BE HOT AND CAUSE PERSONAL INJURY.

- a. Perform heat test by carefully touching or placing a hand near the shock absorber body below the dust cover. Touch the frame to get an ambient reference, see Figure 7-18. A shock absorber that is warm to the touch is acceptable, a cold shock absorber should be replaced.
2. **Physical Inspection:** To inspect for an internal failure, remove and shake the suspected shock absorber. Listen for the sound of metal parts rattling inside. Rattling of metal parts can indicate that the shock absorber has an internal failure and the shock absorber should be replaced.

FIGURE 7-18



VISUAL INSPECTION

Look for these potential problems when doing a visual inspection. Inspect the shock absorbers fully extended. Replace as necessary.

FIGURE 7-19

SHOCK ABSORBER VISUAL INSPECTION - UNACCEPTABLE CONDITIONS

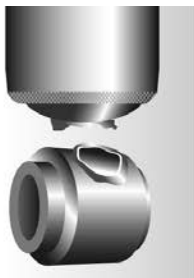

Damaged upper or lower mount



Damaged upper or lower bushing



Damaged dust cover and / or shock body



Bent or dented shock absorber

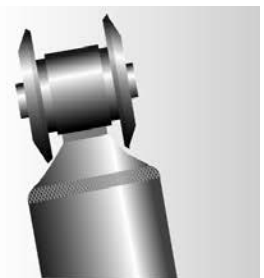

Improper installation
Example: washer (if equipped installed backwards)

LEAKING VS. MISTING SHOCK VISUAL INSPECTION

The inspection must not be conducted after driving in wet weather or a vehicle wash. The shock absorber needs to be free from water.

Many shock absorbers are often misdiagnosed as failures. Misting is the process whereby very small amounts of shock absorber fluid evaporate at a high operating temperature through the upper seal of the shock absorber. When the "mist" reaches the cooler outside air, it condenses and forms a film on the outside of the shock absorber body. Misting is perfectly normal and necessary function of the shock absorber. The fluid which evaporates through the seal area helps to lubricate and prolong the life of the seal.

FIGURE 7-20

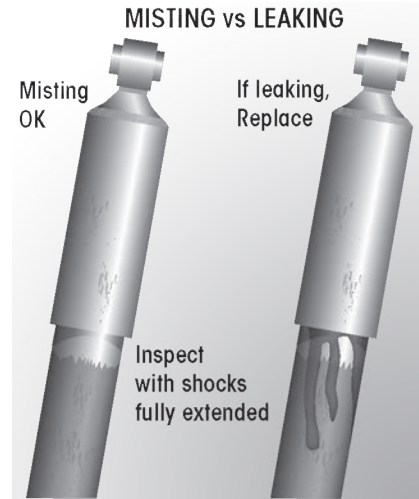

NOTE

AIRTEK NXT suspension systems are equipped with a premium seal on the shock absorber, however this seal will allow for misting to appear on the shock absorber body (misting is not a leak and is considered acceptable).

Inspect the shock absorber fully extended. **A shock absorber that is truly leaking** will show signs of fluid **leaking in streams from the upper seal**. These streams can easily be seen, underneath the main body (dust cover) of the shock absorber. Replace as necessary.

TRAAX ROD TRANSVERSE TORQUE RODS

Transverse TRAAX ROD torque rod length is determined by the centering the axles under the frame.

- If the lateral alignment of the axles is incorrect, it may be necessary to shim the transverse torque rod at the straddle mount end. Shims can be installed between the transverse torque rod and the transverse torque rod frame bracket or between the transverse torque rod and axle tower bracket. Refer to the vehicle manufacturer for proper shim location; also see Lateral Alignment in the Alignment & Adjustments section in this publication.
- The TRAAX ROD transverse torque rods control axle walk-out during cornering. The mounting brackets at the chassis end of the torque rods are furnished and welded into position by vehicle manufacturer.
- **TRAAX ROD torque rods are non-rebushable.** The entire torque rod assembly must be replaced. This feature provides superior bushing retention in the torque rod end hub.

NOTE

It is important that the **tightening torque** of the locknuts be checked during preventive maintenance and service. Follow the tightening torque specifications and all applicable preventive maintenance, service, and safety instructions issued by the respective vehicle and suspension manufacturers.

NOTE

Hendrickson recommends the use of Grade 8 bolts and Grade C locknuts for all straddle mount torque rod attachments.

VISUAL TIRE INSPECTION

The following tire inspection guidelines are based upon Technology & Maintenance Council (TMC) recommended practices. Any issues regarding irregular tire wear where Hendrickson is asked for assistance, will require tire and alignment maintenance records, reference RP 642 in TMC Recommended Practices Manual.

Tire wear is normally the best indicator of vehicle alignment condition. If tires are wearing too rapidly or irregularly, alignment corrections may be needed. The tire wear patterns described below can help isolate specific alignment problems.

The most common conditions of concern for steer tires are: cupping, diagonal wear, feather wear, one-sided wear, overall fast wear (Miles per 32nd), and rapid shoulder wear (one shoulder only).

FIGURE 7-21

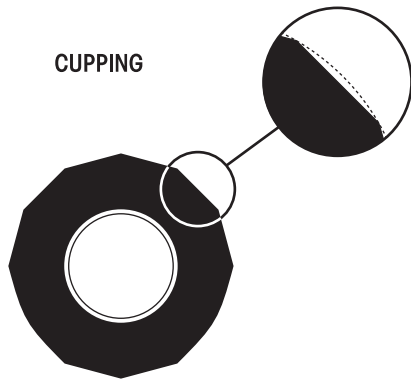

Cupping — Localized, dished out areas of fast wear creating a scalloped appearance around the tire. Cupping, which appears around the tire on the shoulder ribs, may also progress to adjoining ribs.

Cupping is usually a result of moderate-to-severe imbalance, improper rim/wheel mounting, excessive wheel end play or other assembly non-uniformity. It can also be due to lack of shock absorber control on some suspension types as well as loose kingpins.

To solve cupping problems:

Tires – Correct mismatch or balance problem. If ride complaints arise, steer tires may be rotated to drive or trailer axle.

Vehicle – Diagnose component imbalance condition, i.e., wheel, rim, hub, brake, drum. Correct as necessary.

Diagonal Wear — Is localized flat spots worn diagonally across the tread at approximately 25-35° angles, often repeating around the tread circumference. For more information.

Diagonal wear is usually caused by bad wheel bearings, toe out, mismounting of tire and wheel assembly to axle, and mismatched duals for size and/or inflation pressures. It may start as brake skid. Diagonal wear is aggravated by high speed empty or light load hauls.

To correct diagonal wear, reverse direction of rotation of the tire. If wear is excessive, true or retread tire. If the source of trouble is the vehicle, diagnose cause and correct as needed.

FIGURE 7-22
DIAGONAL WEAR

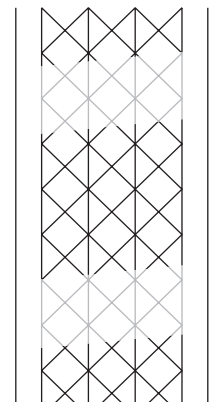
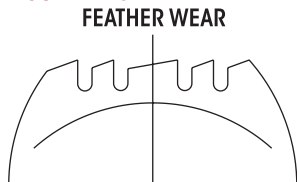

FIGURE 7-23



Feather wear — Tread ribs or blocks worn so that one side is higher than the other resulting in step-offs across the tread face. Generally, all ribs or blocks exhibit this wear.

To spot this problem do the following: With one hand flat on the tread of the tire and a firm down pressure, slide your hand across the tread of the tire. In one direction, the tire will feel smooth and in the opposite direction there will be a sharp edge to the tread.

If feather wear on both steer tires is in the same direction, drive axle or other chassis misalignment is indicated. If one steer tire shows feather wear and the other steer tire has normal wear, a combination of toe and drive axle or chassis misalignment is indicated.

FIGURE 7-24
ONE-SIDED WEAR

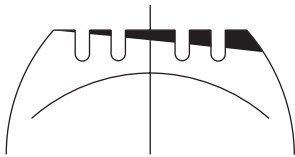

One-sided wear — Is excessive wear on one side of tire extending from the shoulder towards the center of the tread.

One-sided wear is usually caused by improper alignment, worn kingpins, loose wheel bearings, excessive negative camber, excessive axle loads, nonparallel axles, or non-uniform tire and wheel assembly caused by improper bead seating or a bent wheel.

To correct one-sided wear:

Tires – Depending on severity, rotate tires to another axle position or, if worn to minimum tread depths, submit for possible retreading.

Vehicle – Diagnose mechanical problem and correct.

FIGURE 7-25
OVERALL FAST WEAR
(Miles per 32nd)

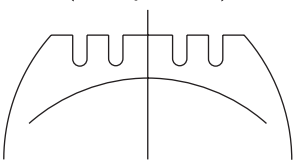

Overall Fast Wear — Fast wear can be described as exhibiting a good, but accelerated wear pattern. It is typically caused by operating conditions, such as mountainous terrain, frequency and severity of turning, abrasive road surfaces in combination with vehicle configurations and their attributes — such as power steering, heavy axle loads, high wheel cuts, setback axles, short wheel base tractors, long wheel base straight trucks. To correct this problem, consult with vehicle and tire manufacturers when specifying equipment or replacing tires.

FIGURE 7-26
RAPID SHOULDER WEAR
(One Shoulder Only)

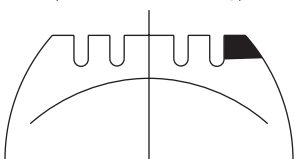

Rapid Shoulder Wear (one shoulder only) — Is a tire worn on the edge of one shoulder, sometimes extending to inner ribs. It can progress to diagonal wipeout.

This wear condition is usually caused by excessive toe or excessive camber. These conditions can be created by a misaligned or bent axle and can also be caused by loose or worn wheel bearings.

To correct this type of rapid shoulder wear:

Tires – Change direction of rotation of tire. If shoulder wear is severe, remove and retread.

Vehicle – Diagnose misalignment and/or mechanical condition and correct.

WHEEL END AND AIR DISC BRAKE ASSEMBLIES AND COMPONENTS

NOTE

Wheel end hubs, seals, bearing cones, hub caps, as well as air disc brake assemblies and components are installed by Hendrickson for new production assembly but these components are not supplied by Hendrickson for aftermarket service purposes. For more information and assistance with service, maintenance and rebuild instructions on these items see the below listed component manufacturers. Refer to the Parts Lists section of this publication for additional information on such assemblies and components.

- **ConMet** 800.547.9473 or www.conmet.com
- **DRiV Incorporated** 800-325-8886 or www.drivparts.com
- **Meritor** 888.725.9355, or www.meritorpartsexpress.com (parts), www.meritorbullpen.com (technical support)
- **WABCO-ZF Friedrichshafen** 855.228.3203 or www.wabco-customercentre.com

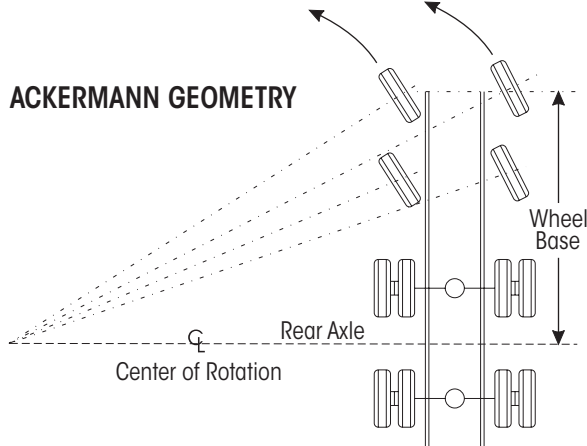
SECTION 8
Alignment & Adjustments
ALIGNMENT DEFINITIONS
FIGURE 8-1

Ackermann Arm (Lower Steering Knuckle) Geometry (Figure 8-1) — The geometry of the four bar linkage consisting of the front axle, two knuckle assemblies, and tie rod assembly is designed to provide free rolling of front tire in a turn. Ackermann geometry is dependent upon the steering axle track-width and wheelbase of the vehicle. Improper geometry results in wheel scrub in turns which generally appears as toe wear on the tire, usually more wear on one side of the vehicle than the other due to the operational route of the vehicle.

Bump steer (feedback) — The feedback felt through the steering linkage to the steering wheel when a steer axle tire hits a bump in the road. This occurs because the axle-end of the drag link and the axle attachment point of the spring do not travel in parallel circular arcs as the suspension moves up and down. This condition can also be caused by trapped air in the power steering system.

Camber (Figure 8-2) — The angle formed by the inward or outward tilt of the wheel reference to a vertical line. Camber is positive when the wheel is tilted outward at the top and is negative when the wheel is tilted inward at the top.

Excessive positive camber may cause smooth wear on the outer half of the tire tread. Excessive negative camber may cause wear on the inner half of the tread. Static-unloaded camber angles are built into the axle to put the loaded tire perpendicular to the road.

Caster (Figure 8-3) — The forward or rearward tilt of the steering axle kingpin in reference to a vertical line. The angle is measured in degrees. Caster is positive when the top of the steering axis is tilted rearward and is negative when the tilt is forward. Proper caster is important for directional stability and returnability. Too much positive caster can cause shimmy, excessive steering effort and is normally a vehicle performance and handling consideration. Uneven positive caster may create a steering pull toward the side with the lower caster. This attribute may be used to compensate for crowned roads.

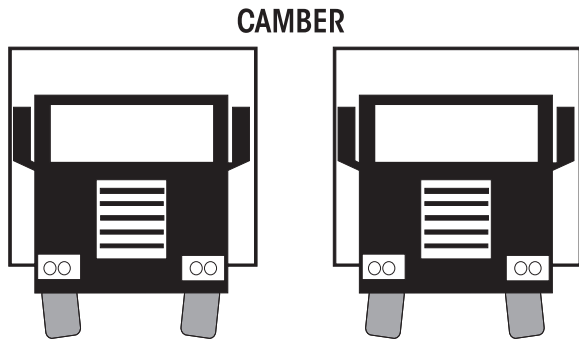
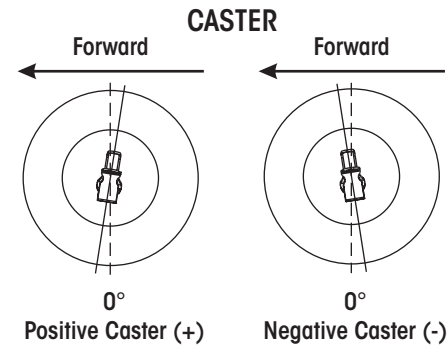
FIGURE 8-2

FIGURE 8-3

Kingpin inclination (KPI) (Figure 8-4) — The inward tilt of the kingpin from the vertical. This front suspension parameter has a pronounced effect on steering effort and returnability. As the front wheels are turned around an inclined kingpin, the front of the truck is lifted. This lifting of the vehicle is experienced as steering effort when the turn is executed and exhibits itself as recovery force when the steering wheel is released.

Kingpin offset (Figure 8-4) — The distance between the center of the tire patch and intersection of the kingpin axis with the ground. This parameter of front-end geometry is important in vehicles without power steering and has a major effect on static steering. If there is no kingpin offset, the tires must scrub around the center of the pin patch when turned in a static condition, resulting in higher static steering efforts.

Steering arm — The component that connects the drag link to the axle knuckle assembly.

FIGURE 8-4

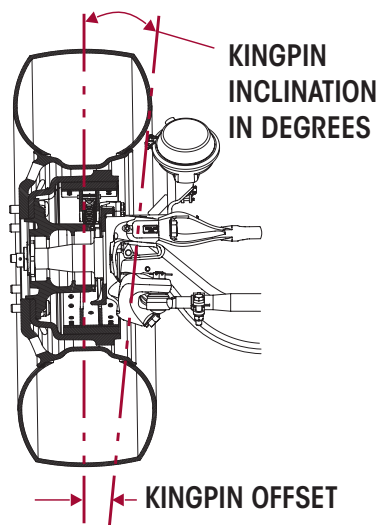

FIGURE 8-5

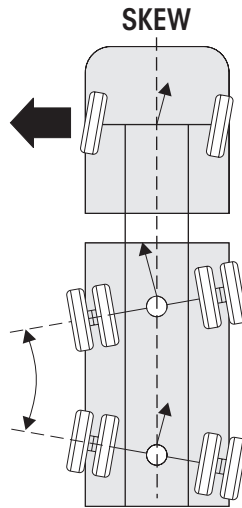
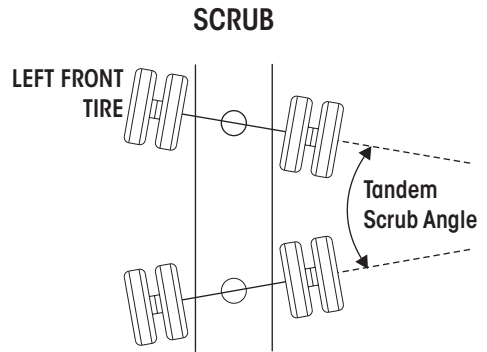

FIGURE 8-6



Scrub, skew, tram angle or parallelism (Figures 8-5 and Figure 6) — The angle formed by two thrust or tracking lines of a tandem (or multiple) axle vehicle. As indicated by the term “parallelism”, the ideal condition is when the two thrust lines form a 0° angle, or are parallel to each other. Positive skew or tram is when the distance between the right axle ends is less than the distance between the left.

Any scrub angle other than 0° will cause the tandem axles to work against each other. The steer axle must be turned to offset the “push” of the tandem axles to keep the vehicle moving straight ahead. This causes every tire on the vehicle to “scrub”. Tire wear from tandem scrubbing occurs at the leading edge of the steer tires in a pattern called “inside/outside” wear, that is, the inside edge of the left steer tire and the outside edge of the right steer tire will exhibit irregular wear for example. Additional tire wear may occur on all tandem axle tires.

Thrust angle, tracking, or square (Figure 8-7) — The angle formed by the centerline of the vehicle frame (geometric centerline) and the direction that an axle points. As indicated by the term “square”, the ideal value for the angle is 0° or when the axle centerline is at 90° or perpendicular to the geometric centerline. Thrust or tracking to the right is positive, and to the left is negative.

FIGURE 8-7

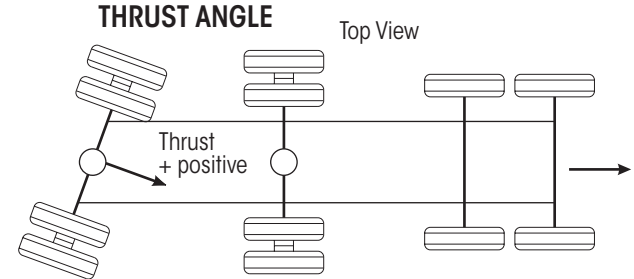

A steering correction is required to offset the effect of the thrust angles and keeps the vehicle traveling in a straight line. It results in a lateral offset between the steer and drive axle tires commonly referred to as “dog tracking.”

Tie Rod Arm (lower steering knuckle, cross tube arm) — The component that transmits steering forces between left and right axle knuckle assemblies through the cross tube assembly.

FIGURE 8-8 TOE-IN

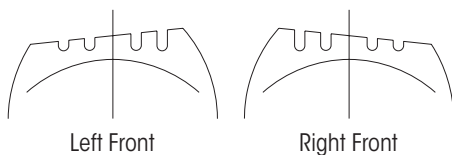

Toe-in (Figure 8-8) — is when the horizontal line intersects in front of the wheels, or the wheels are closer together in front than in the back. Toe-in is commonly designated as positive, toe-out as negative. Excessive toe-in wears the outside edge of the tires. Steer axle toe is adjustable to reduce wear to the leading edge of the tire and also to avoid road wander. Toe is adjusted in a static, unloaded condition so that the tires will run in a straight line under a dynamic, loaded condition.

FIGURE 8-9 TOE-OUT

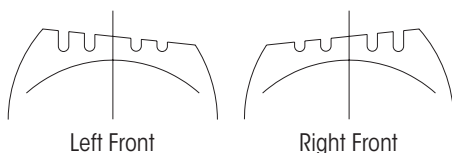

Toe-out (Figure 8-9) — Is when the horizontal lines intersect behind the wheels, or the wheels are closer together in back than in front. Toe-in is commonly designated as positive, toe-out as negative. Excessive toe-out wears the inside edge of the tires. wSteer axle toe is adjustable to reduce wear to the leading edge of the tire and also to avoid road wander. Toe is adjusted in a static, unloaded condition so that the tires will run in a straight line under a dynamic, loaded condition.

Toe-out on turns — (See Ackermann Geometry). Excessive turning angles such as those encountered in pickup and delivery operations may contribute to premature tire wear. Be advised that the greater turning angles, the more that toe and camber change. If you have any doubt regarding the optimum turning angles for your operation, contact the vehicle's manufacturer, axle manufacturer, tire manufacturer and alignment equipment manufacturer for advice.

Total toe (Figure 8-10) — The angle formed by two horizontal lines through the planes of two wheels. Steer axle toe is adjustable to reduce wear to the leading edge of the tire and also to avoid road wander. Toe is adjusted in a static, unloaded condition so that the tires will run in a straight line under a dynamic, loaded condition. Total toe should be set individually for each front axle.

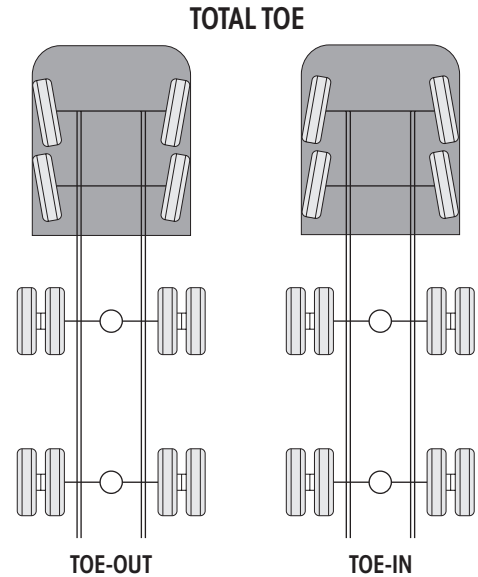
FIGURE 8-10

INSPECTION PRIOR TO ALIGNMENT

WHEELS AND TIRES

Examine the following items:

- The tires are inflated to the manufacturer's specified tire pressure
- The steer axle tires are the same size and type
- The lug nuts are tightened to manufacturer's specified torque
- The wheels are balanced
- The wheels and tires are free of excessive wear and damage
- Wheel bearing end play is within vehicle manufacturer's specification

FRONT SUSPENSION

Inspect the following:

- All fasteners are installed and tightened to the specified torque. See Torque Specifications section of this publication
- Leaf springs are free of wear or damage
- Shock absorbers are free of wear and damage
- Vehicle ride height for both the front and rear axles are within specification. Follow manufacturer's guidelines (if equipped)
- Front and rear spring mounts are free of wear or damage

INSPECT TIE ROD ENDS

Perform the Tie Rod Inspection procedure; refer to the Preventive Maintenance section in this publication.

REAR AXLE AND REAR SUSPENSION

The rear axle can cause front tire wear. If the outer edge of one (1) front tire is worn and the inner edge of the other front tire is worn, check the following:

- Ensure the rear axle (especially a tandem axle) is correctly aligned. Refer to the procedure dictated by the vehicle or suspension manufacturer.
- All fasteners including U-bolts (if applicable) are installed and tightened to the specified torque.
- The leaf springs are not worn or damaged



- The bushings in the leaf springs are not worn or damaged
- The torque rods (if used) are correctly adjusted (if adjustable)
- The frame is not bent or twisted
- Refer to any additional recommendations and specifications from the vehicle manufacturer on the rear axles and suspensions.

FRONT WHEEL ALIGNMENT

Hendrickson recommends technicians review the TMC Guidelines for Total Vehicle Alignment (TMC RP 642).

Check total (front and rear) vehicle wheel alignment when any of the following occurs:

- Every 10,000 miles (16,000 km), or 12 months (normal maintenance), whichever comes first.
- When the vehicle does not steer correctly.
- To correct a tire wear condition.

For **rear** wheel alignment specifications and adjustment refer to the vehicle manufacturer.

The **front** wheel alignment specifications can be found in the Alignment section of this publication. There are two types of front wheel alignment:

1. **Minor alignment** – a minor front wheel alignment is done **for all** normal maintenance conditions, see below.
2. **Major alignment** – a major alignment is done when uneven or excessive tire wear is evident, or response at the steering wheel is sluggish, or the need for major wheel alignment check and adjustment is required, see below.

MINOR FRONT WHEEL ALIGNMENT

Perform the minor front wheel alignment in the following sequence:

1. Inspect all systems that affect wheel alignment. Refer to Inspection Prior to Alignment in this section.
2. Check the wheel bearing end play.
3. Check and adjust toe if necessary.
4. Check and adjust the vehicle ride height as per vehicle manufacturer.

MAJOR FRONT WHEEL ALIGNMENT

Be certain to follow wheel alignment inspection intervals as specified by the original equipment manufacturer. Before performing a major front wheel alignment it is recommended that alignment equipment calibration be checked to ensure proper vehicle alignment.

Major wheel alignment is accomplished in the following sequence of operation:

1. Inspect all the systems that influence the wheel alignment. Refer to the Inspection Prior to Alignment in this section.
2. Check and adjust the maximum turn angle, refer to the Steering Stop Adjustment Procedure in this section, see Figures 8-11 and 8-12.
3. If the vehicle is equipped with power steering, check the pressure relief in the power steering system and reset if necessary. Refer to the vehicle manufacturer regarding the subject: Adjusting the Pressure Relief in the Power Steering System.
4. Check the turning angle. Refer to the original equipment manufacturer specifications.
5. Check the kingpin (or steering axis) inclination. Refer to Kingpin Inclination under Alignment Definitions in this section.



FIGURE 8-11



FIGURE 8-12



WARNING

AXLE CAMBER AND CASTER ARE NOT ADJUSTABLE. DO NOT CHANGE THE AXLE CAMBER ANGLE, CASTER, OR BEND THE AXLE BEAM. BENDING THE AXLE BEAM TO CHANGE THE CAMBER ANGLE CAN DAMAGE THE AXLE AND REDUCE AXLE STRENGTH, AND WILL VOID HENDRICKSON'S WARRANTY. A BENT AXLE BEAM CAN CAUSE LOSS OF VEHICLE CONTROL, POSSIBLY CAUSING PERSONAL INJURY OR PROPERTY DAMAGE, SEE FIGURE 8-13.

6. Check the camber angle. **DO NOT** attempt to adjust. Refer to Camber in the Alignment Definitions in this section.

FIGURE 8-13

STEERTEK NXT
Vocational Steer Axle System

This article is covered by at least one or more of the U.S. and/or foreign patents and/or pending U.S. and/or foreign patent applications posted at:
www.hendrickson-intl.com/patents

HENDRICKSON Truck Commercial Vehicle Systems
www.hendrickson-intl.com | 1.866.755.5968

WARNING

UNAUTHORIZED WELDING OR MODIFICATIONS can cause cracks or other axle structural damage and result in loss of vehicle control, severe personal injury or death.

■ Do not bend, weld or modify axle without authorization from Hendrickson Truck Commercial Vehicle Systems.

© 2016 Hendrickson USA, L.L.C. All Rights Reserved
Part No. 60905-043 A

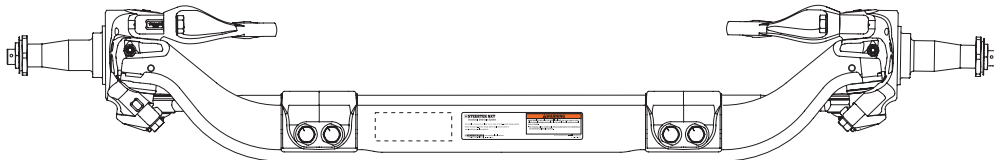

SERVICE HINT

Ensure the rear air suspension (if equipped) ride height is within specification prior to performing a caster measurement or adjustment. The rear ride height must be correct to achieve proper caster.

7. Check caster angle and cross caster (both the caster angle and cross caster are non-adjustable). Refer to Caster in the Alignment Definitions in this section. Cross caster is the difference between the caster readings for left and right side of the vehicle.
8. Check and adjust toe-in, refer to Toe Setting in this section.

STEERING STOP

ADJUSTMENT PROCEDURE

NOTE

When the axle or lower steering knuckle is replaced, the steering stop adjustment must be checked.

You will need:

- 15/16"- 60°/15° angle dual open-end wrench (Martin Tools part number 3719), see Special Tools section of this publication.
- 5/8" open-end wrench

INSPECTION

Inspect the steering axle stop bolt threads for threadlocker, if none is present, apply Loctite 242 or equivalent on the bolt threads prior to tightening.

ADJUSTMENT PROCEDURE

1. Position the vehicle on turntables and chock the rear wheels.
2. Measure the wheel cut:
 - Wheel cut is determined by the steering angle of the tires.
 - Measurement is taken at the **inside wheel only**.
 - Turn the tires to the **full lock position** in both right-hand and left-hand directions.
 - Refer to the vehicle manufacturer's specifications for the exact wheel cut values.

WARNING

ALWAYS CHECK/RESET THE STEERING GEAR BOX POPPET WHEN THE WHEEL CUT IS DECREASED. FOLLOW MANUFACTURER'S GUIDELINES FOR THE GEAR BOX POPPET RESETTING PROCEDURE. FAILURE TO DO SO CAN RESULT IN PREMATURE FAILURE OF THE AXLE OR STEERING KNUCKLE. THIS CONDITION CAN CAUSE LOSS OF VEHICLE CONTROL, POSSIBLE PERSONAL INJURY OR PROPERTY DAMAGE AND VOID ANY APPLICABLE WARRANTY.

3. To **Increase / Decrease** the wheel cut:
 - a. Remove the ABS sensor by prying gently with a standard screwdriver, see Figure 8-14.

FIGURE 8-14

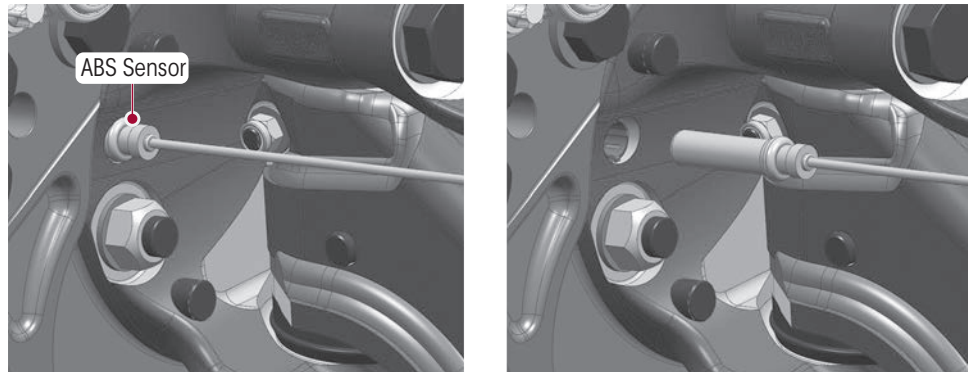

- b. Insert $\frac{15}{16}$ " wrench between knuckle and axle housing from side opposite the steer stop bolt to reach the jam nut, see Figures 8-15 and 8-16.
 - c. Rotate the wrench and flip as needed to achieve a full rotation of the jam nut flats, see Figure 8-17.

FIGURE 8-15

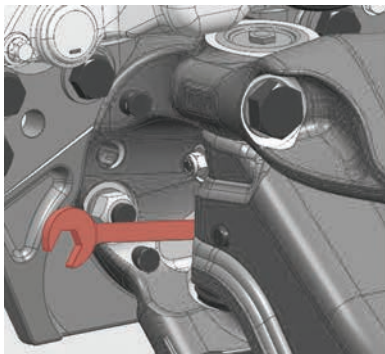

FIGURE 8-16

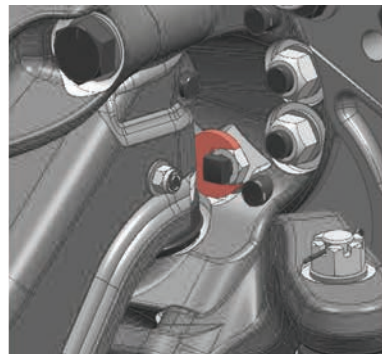
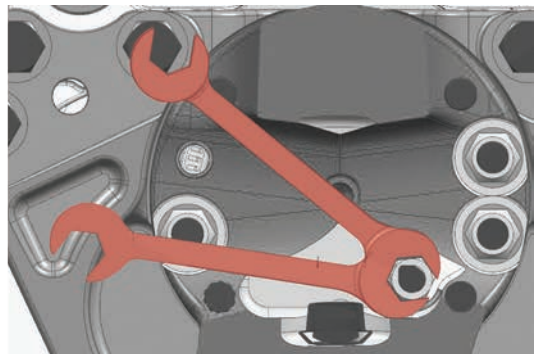

FIGURE 8-17



- d. Loosen the jam nuts and turn the steering stop bolt:
 - **Clockwise (in) to increase the wheel cut**
 - **Counter-clockwise (out) to decrease the wheel cut**



- e. Hold the stop bolt with a $\frac{5}{8}$ " wrench while tightening the jam nut to \mathbb{R} 50 ± 10 foot pounds torque, see Figure 8-18.
- f. Reinstall ABS sensor.

NOTE

Verify that the sides of the square head axle stops are parallel to the axle beam for proper contact, see Figure 8-19.

4. Measure the wheel cut again and check for any interference with the related steering components.

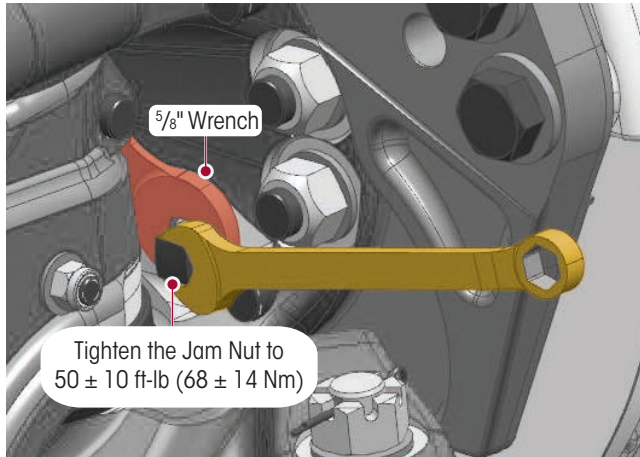
FIGURE 8-18**FIGURE 8-19****TOE SETTING**

1. Place the vehicle on a level floor with the wheels in a straight ahead position.
2. Raise the vehicle and support the front axle with safety stands.
3. Chock the rear wheels of the vehicle.
4. Use paint and mark the center area of tread on both steer axle tires around the complete outer diameter of the tires.
5. Scribe a line through both steer axle tires in the painted area around the complete outer diameter of the tires.
6. Raise the vehicle and remove the safety stands.
7. Set the vehicle on the ground.

NOTE

DO NOT measure toe-in with the front axle off the ground. The weight of the vehicle must be on the front axle when toe-in is measured.

8. Use a trammel bar and measure the distance between the scribe marks at the rear of the steer axle tires. Record the measurement.
9. Install the trammel bar and measure the distance between the scribe marks at the front of the steer axle tires. Record the measurement, see Figure 8-20.

NOTE

When setting up the trammel bar the pointers should be level with the spindles at the front and rear of the steer axle tires.

10. To calculate the toe setting subtract the front measurement from the rear measurement, the difference between the two will equal the toe-in/toe-out measurement.
11. If the toe measurement is not within the specifications of $\frac{1}{16} \pm \frac{1}{32}$ (0.060 ± 0.030), it will be necessary to adjust the toe setting. Refer to the following procedure.
 - a. Loosen the tie rod cross tube clamp bolts and locknuts.
 - b. Turn the tie rod cross tube until the specified toe-in distance is achieved.
 - c. Tighten the bolt and locknut on the tie rod cross tube to \mathbb{R} 68 ± 7 foot pounds torque.

FIGURE 8-20

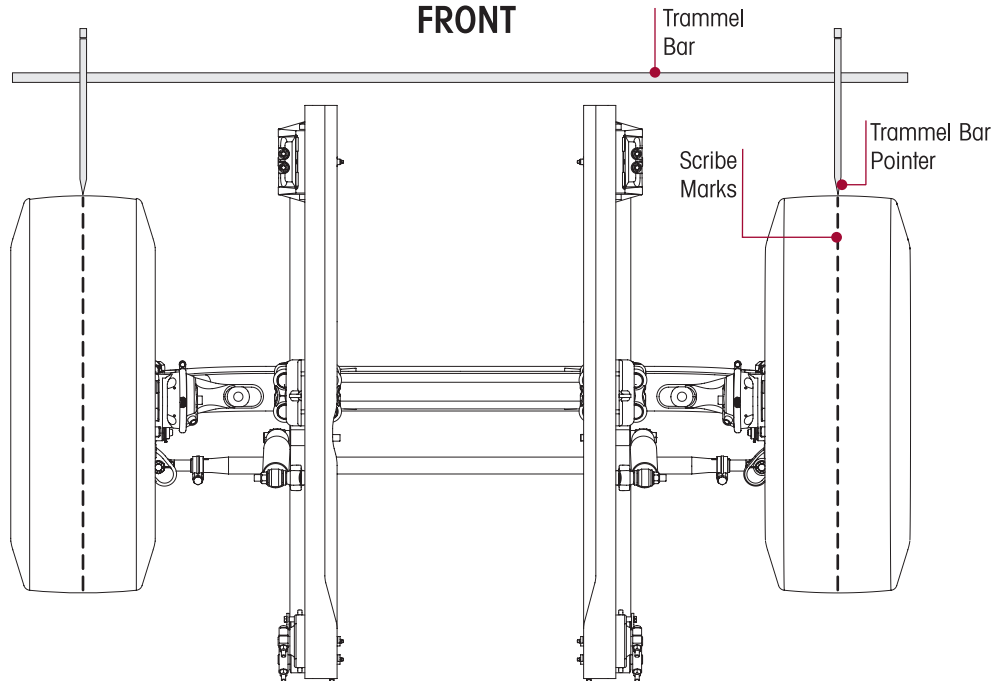
WARNING

THE THREADED PORTION OF THE TIE ROD END MUST EXTEND PAST THE SLOTS INTO THE TIE ROD (SEE FIGURE 8-21) IT IS CRITICAL TO CHECK THE $\frac{3}{4}$ " TIE ROD CLAMP BOLT HEAD LOCATION TO VERIFY THE CLAMP FASTENERS HAVE SUFFICIENT CLEARANCE AWAY FROM THE LOWER SHOCK MOUNT AT FULL WHEEL CUT. THE FASTENERS MUST NOT CONTACT THE LOWER SHOCK MOUNT. FAILURE TO DO SO CAN CAUSE ONE OR MORE COMPONENTS TO FAIL CAUSING LOSS OF VEHICLE CONTROL AND POSSIBLE PERSONAL INJURY OR PROPERTY DAMAGE.

12. Verify the tie rod clamp bolt head does not contact the lower shock mount at full wheel cut, see Figure 8-21.
13. Repeat Steps 1-10 until the correct toe setting is achieved.
14. Remove the vehicle frame safety stands and lower the vehicle.
15. Remove the rear wheel chocks.

FIGURE 8-21

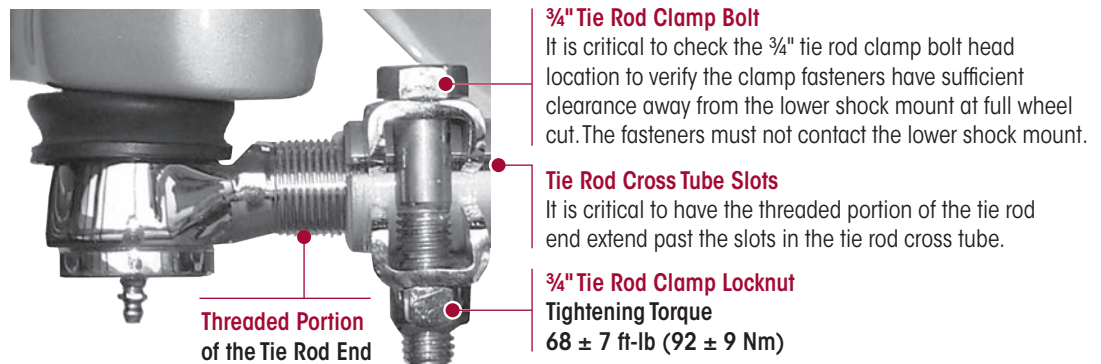



RIDE HEIGHT

1. Use a work bay with a level floor. Drive the vehicle slowly, straight ahead. Try to slacken or loosen the suspension as the vehicle is positioned. End with all the wheels positioned straight ahead.
2. Roll to a stop without the brakes being applied.
3. Chock the drive wheels. **DO NOT** set parking brake.
4. Verify that the air system is at full operating pressure.

NOTE

The height control valve is only located in the center of Steer Axle 1.

5. On the front forward axle **Steer Axle 1**, detach the lower rubber grommet of the height control valve linkage from the lower stud and exhaust the suspension system air by lowering the height control valve linkage arm.
6. Re-attach the lower grommet of the height control valve linkage onto the lower stud to fill the suspension system with air. Wait until the airflow to the front forward air springs have stopped.
7. Measure the suspension reference ride height from the bottom of the frame to the top of the top pad jounce stop on the front forward axle, driver's side (left side of the vehicle), as shown in Figure 8-22.
 - **Referenced ride height** dimension is $2.93" \pm 1/8"$. If the ride height is out of specification, it will be necessary to adjust the ride height.

FIGURE 8-22

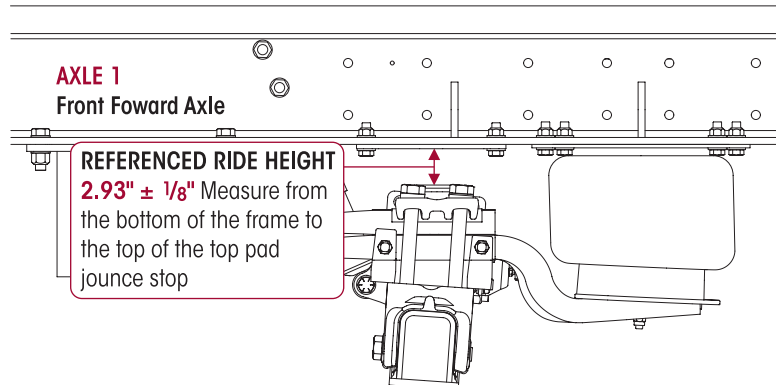

ADJUSTMENT PROCEDURE

1. Verify that the air system is at full operating pressure.

SERVICE HINT

It is very important that the leveling valve be cycled completely before and after any ride height adjustments. Cycling of the leveling valve will help make the adjustment more accurate.

2. See Air Spring Safety Notice in the Important Safety Notice section of this publication prior to deflating or inflating the suspension system.
3. Cycle the air system. Detach the lower rubber grommet of the height control valve linkage from the lower stud and exhaust the suspension system air by lowering the height control valve arm.
4. Refill the suspension by raising the height control valve arm by hand, so that the air springs are above the proper ride height.
5. Lower the height control valve arm(s) to exhaust the air system until the suspension is at the proper ride height as measured.
6. Rotate the lever and set to neutral position (deadband) for the height control valve(s) by aligning the notches in the height control valve arm(s) with the hole in the height control valve cover, as shown in Figure 8-23. Insert a golf tee to keep the arm from rotating.

SERVICE HINT

DO NOT back out the studs from the height control valve body. Loosening the studs may cause the height control valve to leak.

7. It may be necessary to loosen the lower clamp to adjust the length of the height control valve linkage.
8. Reconnect the linkage rubber grommet to the link mounts. Allow the air suspension system to completely fill with air.
9. Recheck the ride height on both sides of Axle 1 after adjustment.
10. If the lower clamp was loosened for adjustment, tighten until securely fastened, see Figure 8-24.
11. Repeat the adjustment if necessary until the ride height is within specification.

FIGURE 8-23

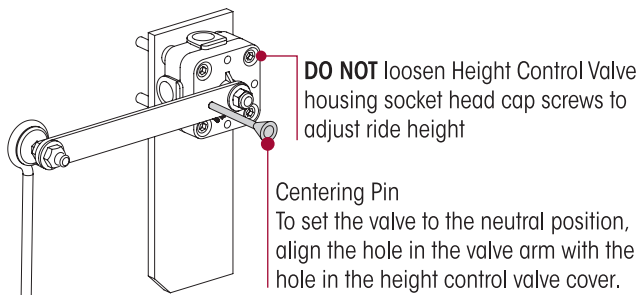
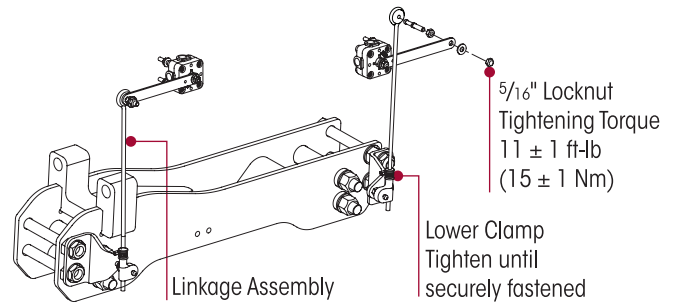

FIGURE 8-24



WHEEL END AND AIR DISC BRAKE ASSEMBLIES AND COMPONENTS

NOTE

Wheel end hubs, seals, bearing cones, hub caps, as well as air disc brake assemblies and components are installed by Hendrickson for new production assembly but these components are not supplied by Hendrickson for aftermarket service purposes. For more information and assistance with service, maintenance and rebuild instructions on these items see the below listed component manufacturers. Refer to the Parts Lists section of this publication for additional information on such assemblies and components.

- **ConMet** 800.547.9473 or www.conmet.com
- **DRiV Incorporated** 800-325-8886 or www.drivparts.com
- **Meritor** 888.725.9355, or www.meritorpartsexpress.com (parts), www.meritorbullpen.com (technical support)
- **WABCO-ZF Friedrichshafen** 855.228.3203 or www.wabco-customercentre.com

SECTION 9
Component Replacement
FASTENERS

Hendrickson recommends that when servicing the vehicle to replace the removed fasteners with new equivalent fasteners. Maintain the correct torque values at all times. Check the torque values as specified, see Hendrickson's Torque Specifications section of this publication. If non-Hendrickson fasteners are used, follow the torque specifications listed in the vehicle manufacturer's service manual.

AIR SPRING
DISASSEMBLY

1. Place the vehicle on level floor.
2. Chock the wheels.
3. Support the frame at ride height with safety stands.



PRIOR TO AND DURING DEFLATION AND INFLATION OF THE AIR SUSPENSION SYSTEM, ENSURE THAT ALL PERSONNEL AND EQUIPMENT ARE CLEAR FROM UNDER THE VEHICLE AND AROUND THE SERVICE AREA, FAILURE TO DO SO CAN CAUSE SERIOUS PERSONAL INJURY, DEATH, OR PROPERTY DAMAGE.



WHEN SERVICING THE VEHICLE OR ATTACHING AN AIR SPRING AND THE VEHICLE IS ON THE GROUND, PRIOR TO AIRING THE SUSPENSION SYSTEM MAKE CERTAIN THE AIR SPRING LOCATOR IS INDEXED INTO THE UPPER AIR SPRING BRACKET PROPERLY, AND THE AIR SPRING IS FULLY SEATED ON THE LOWER AIR SPRING BRACKET. FAILURE TO FOLLOW THESE INSTRUCTIONS COULD RESULT IN PREMATURE AIR SPRING FAILURE, CAUSE PERSONAL INJURY, OR PROPERTY DAMAGE.

4. See additional Air Spring Cautions and Warnings in the Important Safety Notice section of this publication prior to deflating or inflating the air system.
5. Disconnect the linkage at the lower rubber grommet to remove the air from the air system and allow the lever to drop. This will exhaust air from the system.
6. Disconnect the air line and remove the air fittings from the air spring assembly.
7. Remove and discard the 1/2" lower air spring fasteners, see Figure 9-1.
8. Remove and discard the 3/4" upper air spring fasteners from the upper air spring bracket / frame hanger assembly per vehicle manufacturer instructions.

NOTE

Upper air spring brackets on steer axle 2 are welded to the frame by vehicle manufacturer. Refer to the vehicle manufacturer for preventive maintenance and service instructions.

9. Remove the air spring assembly.

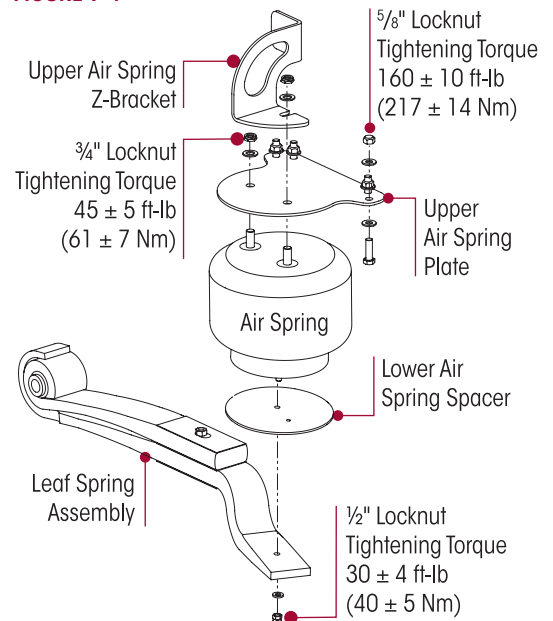
FIGURE 9-1

**ASSEMBLY**

1. Compress the air spring and slide into vertical position.
2. Locate ¼" PTC fitting and ½" threaded stud on top of the air spring.
3. Guide the bottom stud and properly seat the lower air spring piston onto the lower air spring spacer and the leaf spring. Secure the ½" locknut to the piston, see Figure 9-1.

SERVICE HINT

DO NOT twist air spring bladder when tightening locknut.

4. Tighten the ¾" upper air spring locknuts to 45 ± 5 foot pound torque and the ½" lower air spring locknut to 30 ± 4 foot pound torque.

WARNING

WHEN SERVICING THE VEHICLE OR ATTACHING AN AIR SPRING AND THE VEHICLE IS ON THE GROUND, PRIOR TO AIRING THE SUSPENSION SYSTEM MAKE CERTAIN THE AIR SPRING LOCATOR IS INDEXED INTO THE UPPER AIR SPRING BRACKET PROPERLY, AND THE AIR SPRING IS FULLY SEATED ON THE LEAF SPRING. FAILURE TO FOLLOW THESE INSTRUCTIONS COULD RESULT IN PREMATURE AIR SPRING FAILURE, CAUSE PERSONAL INJURY, OR PROPERTY DAMAGE.

5. See Air Spring Warnings and instructions in the Important Safety Notice section in this publication prior to deflating or inflating the suspension system.
6. Connect the air line into the air spring assembly.
7. Raise the truck with floor jack and remove frame stand supports.
8. Lower the truck to the ground.
9. Air up the suspension.
10. Verify the ride height is within specification, see the Alignment & Adjustments section in this publication for the proper ride height adjustment.
11. Remove the wheel chocks.

AXLE BRACKET**DISASSEMBLY****NOTE**

Service only one axle bracket at a time.

1. Chock the wheels.
2. Support the frame of the vehicle at ride height with safety stands.
3. Remove the wheel assemblies on the axle being serviced per the vehicle manufacturer's instructions.
4. On the front forward axle **Steer Axle 1**, detach the lower rubber grommet of the height control valve linkage from the lower stud and exhaust the suspension system air by lowering the height control valve linkage arm.
5. On the axle being serviced, remove and discard ¾" lower shock absorber fasteners.
6. On the axle being serviced, slide the lower shock absorbers out of lower shock bracket.
7. On the axle being serviced, remove and discard the 7/8" torque rod fasteners from the axle bracket, see Figure 9-2.

NOTE

It is not necessary to remove the torque rod fasteners from the vehicle frame.

8. Remove and discard ¾" axle bracket fasteners from the lower linkage bracket, see Figure 9-2.
9. Remove and discard ¾" axle bracket fasteners from the bottom cap.
10. Remove the axle bracket.
11. Remove and discard ¾" axle bracket fasteners from the lower shock bracket, see Figure 9-2.

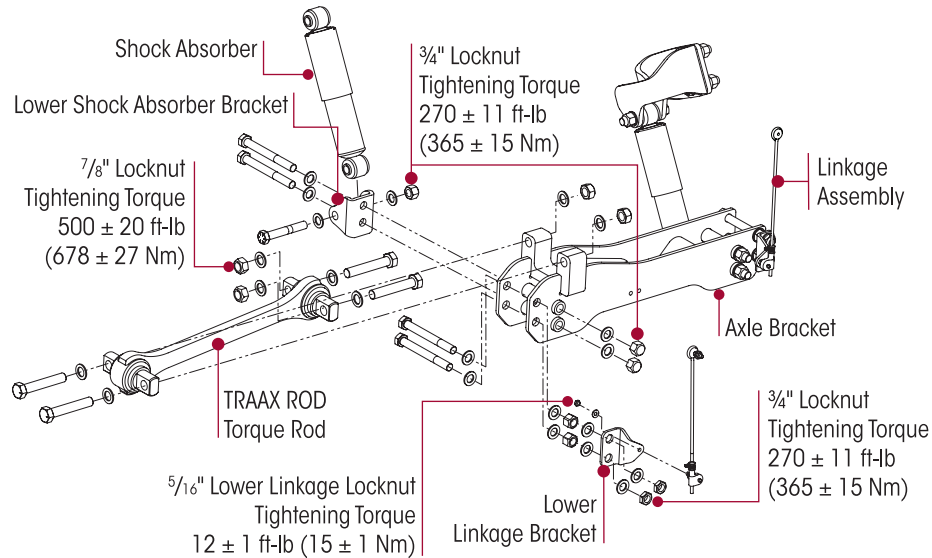
FIGURE 9-2

INSPECTION

Inspect the mounting surface of the torque rod axle bracket, shock absorber mounting bracket, and lower linkage bracket for damage or wear. Repair or replace as necessary.

ASSEMBLY

1. Install the lower shock brackets onto the axle bracket. Install the 3/4" fasteners and tighten to 270 ± 11 foot pounds, see Figure 9-2.
2. Install the axle bracket onto the bottom cap. Install the 3/4" fasteners and tighten to 270 ± 11 foot pounds.
3. Install the lower linkage bracket onto the axle bracket. Install the 3/4" fasteners and tighten to 270 ± 11 foot pounds, see Figure 9-2.
4. Install the transverse TRAAX ROD onto the axle bracket. Install the 7/8" torque rod fasteners and tighten to 500 ± 20 foot pounds see Figure 9-2.
5. Install the linkage assembly onto the lower linkage bracket. Install the 5/16" fasteners and tighten to 12 ± 1 foot pounds, see Figure 9-2.
6. Install the shock absorbers into the lower shock brackets. Install the 3/4" fasteners and tighten to 270 ± 11 foot pounds, see Figure 9-2.
7. Install the wheel assembly per the vehicle manufacturer's instructions.
8. Remove the frame safety stands.
9. Inflate the suspension slowly and verify that the air spring bladder inflates uniformly without binding.
10. Verify the vehicle ride height is within the vehicle manufacturer's specifications.
11. Perform a lateral vehicle alignment (necessary anytime the transverse torque rod is removed), refer to the Alignment & Adjustment section in this publication.

HEIGHT CONTROL VALVE AND LINKAGE ASSEMBLY

The vehicle manufacturer recommends dual height control valves are only to be installed on the rear suspension when the front suspension is equipped with a single height control valve system. This arrangement is best suited to keep the vehicle level versus having dual height control systems on both the front and rear suspensions.

NOTE

This procedure is for servicing a height control valve supplied by Hendrickson. Contact the vehicle manufacturer for instructions when servicing a non-Hendrickson height control valve.

DISASSEMBLY

1. Chock the wheels of the vehicle.

WARNING

PRIOR TO AND DURING DEFLATION AND INFLATION OF THE AIR SUSPENSION SYSTEM, ENSURE THAT ALL PERSONNEL AND EQUIPMENT ARE CLEAR FROM UNDER THE VEHICLE AND AROUND THE SERVICE AREA, FAILURE TO DO SO CAN CAUSE SERIOUS PERSONAL INJURY, DEATH, OR PROPERTY DAMAGE.

2. See additional Air Spring Cautions and Warnings in the Important Safety Notice section in this publication prior to deflating or inflating the air system.
3. Disconnect the height control linkage assembly from the height control valve arm by sliding the rubber grommet off the height control valve arm's stud. Lower the height control valve arm to exhaust the air in the air springs and deflate the rear suspension.

WARNING

SOME VEHICLE APPLICATIONS, SUCH AS VEHICLES EQUIPPED WITH OUTRIGGERS, RETAIN SOME AIR PRESSURE IN THE AIR SPRINGS AT ALL TIMES. PRIOR TO PERFORMING ANY MAINTENANCE, SERVICE, OR REPAIR OF THE SUSPENSION, VERIFY EACH AIR SPRING IS COMPLETELY DEFLATED. FAILURE TO DO SO COULD RESULT SERIOUS PROPERTY DAMAGE AND/OR SEVERE PERSONAL INJURY.

FIGURE 9-3

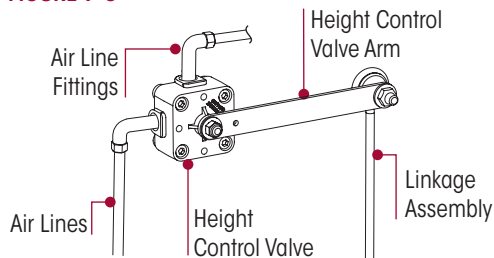

4. Remove the air lines from the height control valve, see Figure 9-3.
5. Remove and discard the locknut fasteners that attach the height control valve to the frame mounting bracket per the vehicle manufacturer's instructions. **DO NOT** back out the studs from the height control valve body. Loosening the studs may cause the height control valve to leak.
6. Remove the height control valve, see Figure 9-4.
7. Remove the air line fittings from the height control valve.

FIGURE 9-4

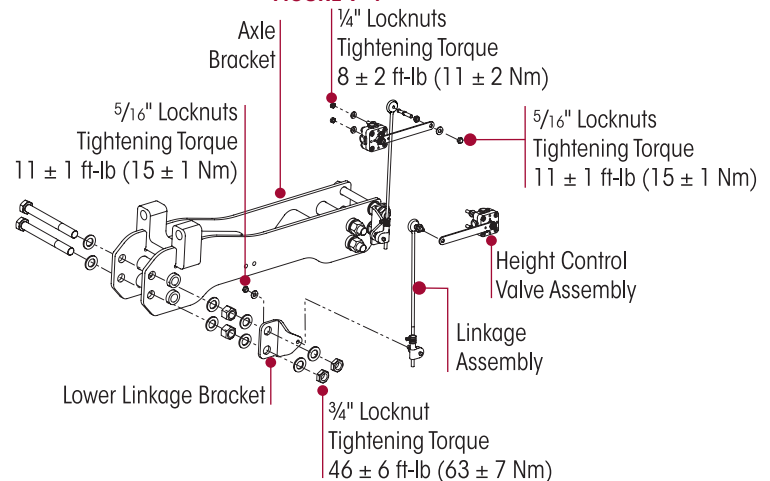

ASSEMBLY

1. Install the air line fittings into the height control valve using Teflon (or equivalent) thread seal.
2. Install the height control valve to the frame mounting bracket and tighten $\frac{1}{4}$ " fasteners to $\boxed{8} \pm 2$ foot pounds torque, see Figure 9-4.
3. Install the air lines to the height control valve. Refer to the Plumbing Diagrams section in this publication.
4. See additional Air Spring Cautions and Warnings in the Important Safety Notice section in this publication prior to deflating or inflating the air system.
5. Inflate the suspension slowly and verify that the air spring bladder inflates uniformly without binding.
6. Reconnect the height control linkage assembly to the height control valve arm. Install the $\frac{5}{16}$ " fasteners and tighten to $\boxed{11} \pm 1$ foot pounds torque, see Figure 9-4.
7. Verify proper ride height adjustment, see Ride Height Adjustment in the Preventive Maintenance section of this publication.
8. Remove the wheel chocks.



SHOCK ABSORBER

NOTE It is not necessary to replace shock absorbers in pairs if only one (1) shock absorber requires replacement.

NOTE Upper shock brackets are welded to the frame by vehicle manufacturer. Refer to the vehicle manufacturer for preventive maintenance and service instructions.



THE SHOCK ABSORBERS ARE THE REBOUND TRAVEL STOPS FOR THE SPRINGS. ANYTIME THE FRONT AXLE ON THE SUSPENSION IS SUSPENDED IT IS MANDATORY THAT THE SHOCK ABSORBERS REMAIN CONNECTED. FAILURE TO DO SO COULD CAUSE THE REVERSE ARCH IN THE STEEL LEAF SPRINGS, POSSIBLY RESULTING IN PREMATURE STEEL LEAF SPRING FAILURE.

DISASSEMBLY

1. Chock the wheels.
2. Remove the lower shock absorber mounting fasteners from lower shock bracket, see Figure 9-5.
3. Remove the upper shock absorber mounting fasteners from the upper shock bracket, see Figure 9-5.
4. Slide out the shock absorber.
5. Inspect the shock absorber mounting brackets and hardware for damage or wear, replace as necessary.

FIGURE 9-5

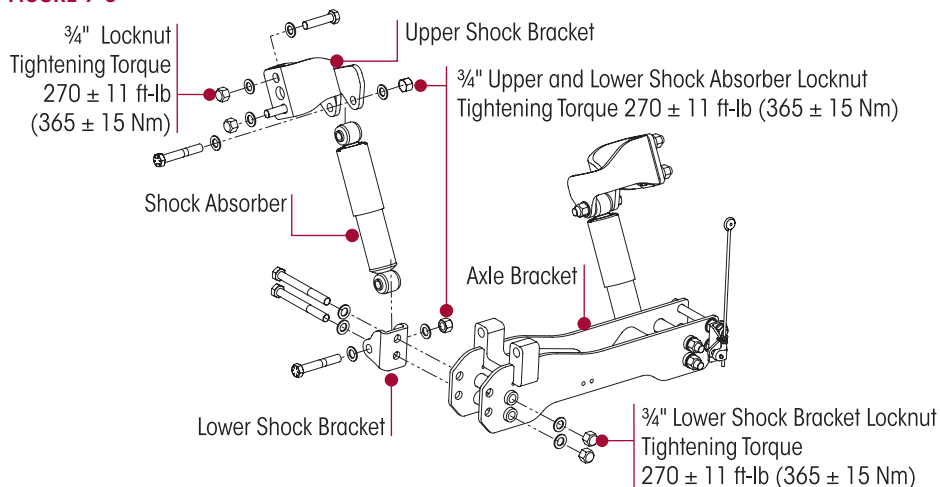

ASSEMBLY

1. Slide the shock absorber into the **upper** shock bracket.
2. Install the upper shock absorber mounting fasteners.
3. Install the lower shock absorber fasteners, see Figure 9-5.
4. Tighten the upper and lower shock absorber 3/4" fasteners to 270 ± 11 foot pounds, see Figure 9-5.
5. Tighten the lower shock bracket 3/4" fasteners to 270 ± 11 foot pounds, see Figure 9-5.
6. Remove the wheel chocks.

TRAAX ROD TORQUE RODS



THIS HENDRICKSON SUSPENSION SYSTEM REQUIRES TORQUE RODS FOR SUSPENSION PERFORMANCE AND VEHICLE STABILITY. IF THESE TORQUE RODS ARE DISCONNECTED OR ARE NON-FUNCTIONAL, DO NOT OPERATE THE VEHICLE. OPERATING A VEHICLE WITH DISCONNECTED OR NON-FUNCTIONAL TORQUE RODS CAN RESULT IN ADVERSE VEHICLE HANDLING, COMPONENT DAMAGE, SUSPENSION/VEHICLE DAMAGE, AND/OR SEVERE PERSONAL INJURY.

NOTE TRAAX ROD torque rod assemblies equipped on the AIRTEK NXT suspension system for EAM Vehicles are not rebushable. The entire torque rod assembly must be replaced. This feature provides superior bushing retention in the torque rod end hub.

DISASSEMBLY

1. Chock the wheels of the vehicle.

SERVICE HINT

Note the quantity and location of shims (if equipped) to maintain the lateral alignment of the axle during assembly.

2. Remove and discard the torque rod mounting fasteners and shims (if equipped) from the frame weldment transverse torque rod bracket as per the vehicle manufacturer's instructions.
3. Remove the fasteners and shims (if equipped) from the axle bracket.
4. Remove the transverse torque rod, see Figure 9-6.
5. Inspect the mounting surfaces for any wear or damage. Repair or replace as necessary.

ASSEMBLY

1. Install the transverse torque rod to the frame weldment transverse torque rod bracket.
2. Install the mounting fasteners and any shims (if equipped) with the same quantity and location as prior to removal to maintain lateral alignment.
3. Install the fasteners and shims (if equipped) from the axle bracket.

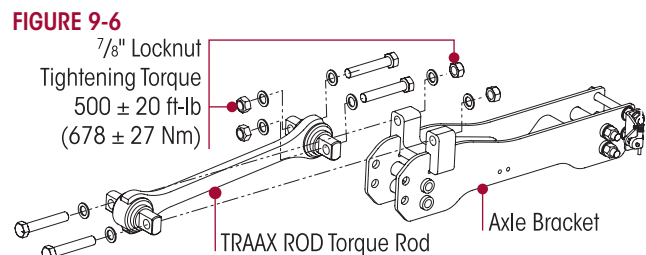

NOTE

Hendrickson recommends using Grade 8 bolts and Grade C locknuts for all torque rod attachments.

4. Prior to tightening fastenes, ensure that the vehicle is at the proper ride height.
5. Tighten 7/8" fasteners to  500 ± 20 foot pounds, see Figure 9-6.
6. Remove the wheel chocks.

FRAME HANGER

DISASSEMBLY

WARNING

PLACE THE VEHICLE ON A LEVEL FLOOR AND CHOCK THE WHEELS TO PREVENT THE VEHICLE FROM MOVING OR ROLLING. DO NOT WORK AROUND OR UNDER A RAISED VEHICLE SUPPORTED BY ONLY A FLOOR JACK. ALWAYS SUPPORT A RAISED VEHICLE WITH RIGID SAFETY STANDS. FAILURE TO DO SO CAN CAUSE SERIOUS PERSONAL INJURY OR DAMAGE TO EQUIPMENT.

1. Place the vehicle on level floor.
2. Chock the wheels.
3. Support the frame at ride height with safety stands.

WARNING

PRIOR TO AND DURING DEFLATION AND INFLATION OF THE AIR SUSPENSION SYSTEM, ENSURE THAT ALL PERSONNEL AND EQUIPMENT ARE CLEAR FROM UNDER THE VEHICLE AND AROUND THE SERVICE AREA, FAILURE TO DO SO CAN CAUSE SERIOUS PERSONAL INJURY, DEATH, OR PROPERTY DAMAGE.

4. See additional Air Spring Cautions and Warnings in the Important Safety Notice section of this publication prior to deflating or inflating the air system.
5. Disconnect the linkage at the lower rubber grommet to remove the air from the air system and allow the lever to drop. This will exhaust air from the system.
6. On the side being serviced, remove and discard the QUIK-ALIGN fasteners, see Figure 9-7.



7. Remove the QUIK-ALIGN collars that connect the leaf spring to the frame hanger.
8. Remove the fasteners that attach the frame hanger to the frame rail.
9. Remove the frame hanger.

FIGURE 9-7

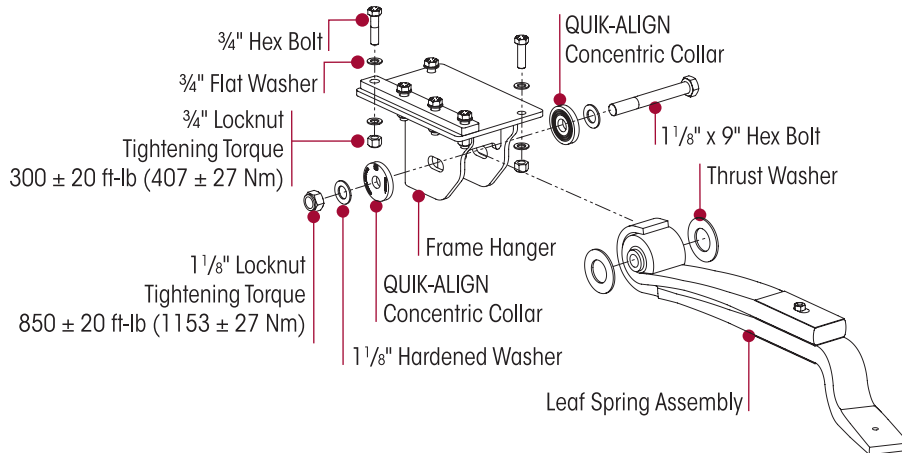

ASSEMBLY

1. Slide the frame hanger over the leaf spring, see Figure 9-7.
2. Install the frame hanger to frame rail. Tighten the 3/4\"/>



WARNING

DO NOT ASSEMBLE THE QUIK-ALIGN JOINT WITHOUT THE PROPER FASTENERS. USE ONLY HENDRICKSON COATED GENUINE FASTENERS TO SUSTAIN PROPER CLAMP FORCE. ENSURE THAT THE QUIK-ALIGN FASTENER'S TORQUE VALUES ARE SUSTAINED AS RECOMMENDED IN THE TORQUE SPECIFICATIONS SECTION IN THIS PUBLICATION. FAILURE TO FOLLOW THE ABOVE ITEMS CAN CAUSE ADVERSE VEHICLE HANDLING RESULTING IN PERSONAL INJURY OR PROPERTY DAMAGE AND WILL VOID ANY APPLICABLE WARRANTIES. FOLLOW THE VEHICLE MANUFACTURER'S FASTENER ORIENTATION WHEN PERFORMING ANY MAINTENANCE, SERVICE, OR REPAIR.

NOTE

Use a new QUIK-ALIGN Kit (see the Parts Lists section in this publication) for any axle alignment or disassembly of the QUIK-ALIGN connection. This helps to ensure that the proper clamp load is applied to the connections so that the joints will not slip in service.

3. Install the QUIK-ALIGN collars and fasteners.
4. Snug the pivot bolt locknut to approximately 100 foot pounds of torque. **DO NOT** tighten to the specified torque at this time.
5. See Air Spring Cautions and Warnings in the Important Safety Notice section of this publication prior to deflating or inflating the air system.
6. Inflate the suspension slowly and verify that the air spring bladder inflates uniformly without binding.
7. Remove the safety stands.
8. Verify proper ride height. Refer to vehicle manufacturer's specifications.
9. Verify that the axle is in proper alignment, see the Alignment & Adjustments section in this publication.

NOTE

Prior to tightening the QUIK-ALIGN locknuts to final torque specifications, it is mandatory that the vehicle be positioned at the proper ride height and alignment.

10. After alignment of the axle is verified, tighten the QUIK-ALIGN fasteners to 850 ± 20 foot pounds torque, see Figure 9-7.
11. Remove the wheel chocks.



LEAF SPRING & CLAMP GROUP ASSEMBLY – Module

NOTE The various leaf spring and clamp group assemblies are sold as separate modules in the aftermarket as well as individual components. The following instructions are to remove and install each such module as a unit from the axle. It also is a preliminary procedure to remove the module to service the assemblies' individual components, refer to the Parts List section in this publication.

NOTE The removal of the leaf spring and clamp group assembly from the axle is done one axle at a time and **one side of the axle with** the other side clamped to the axle to prevent axle movement during service.

You will need:

- Axle collar driver, refer to the Special Tools section of this publication.

REMOVAL FROM AXLE

1. Place the vehicle on a level floor.
2. Chock the wheels.
3. Raise the vehicle and support with safety stands.
4. Raise and support the axle with a safety stand.
5. Remove the wheel assembly on the side being serviced per the vehicle manufacturer's instructions.
6. Remove the air spring as per the Air Spring instructions in this section.
7. Remove the torque rod axle bracket assembly as shown in this section.
8. Remove and discard the QUIK-ALIGN fasteners.
9. Remove the QUIK-ALIGN collars.
10. Partially remove the axle collar bolts with a couple of threads engaged, see Figure 9-8.
11. Strike the bolt heads with a hammer to dislodge and drive out the axle collars.
12. Remove axle collar and bolts.
13. Install the collar bushing driver from the tie rod side of the axle, see Figure 9-9.

FIGURE 9-8



FIGURE 9-9

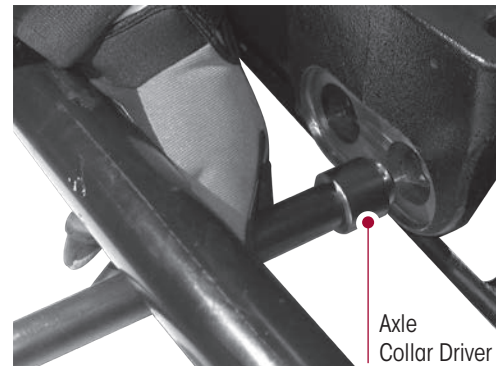

14. To remove the axle collars, strike the bushing driver to dislodge and drive out the axle collars, Figure 9-10, until the axle collars are clear from the axle, see Figure 9-11.
15. **Lower the axle** until there is sufficient clearance to remove the leaf spring from the frame hanger and clamp group assembly on the side being serviced from the axle.
16. **On the side being serviced**, remove and discard the axle seat fasteners.
17. Remove and discard thrust washers.



WARNING

THE WEIGHT OF THE LEAF SPRING AND CLAMP GROUP ASSEMBLY IS APPROXIMATELY 250 POUNDS. CARE SHOULD BE TAKEN AT REMOVAL AND INSTALLATION TO PREVENT PERSONAL INJURY OR DAMAGE TO COMPONENTS.



18. Remove the leaf spring and clamp group assembly from the axle.

19. Remove and discard the spring liner.

FIGURE 9-10



Strike on the bolt side of the axle to remove non threaded axle collar

FIGURE 9-11

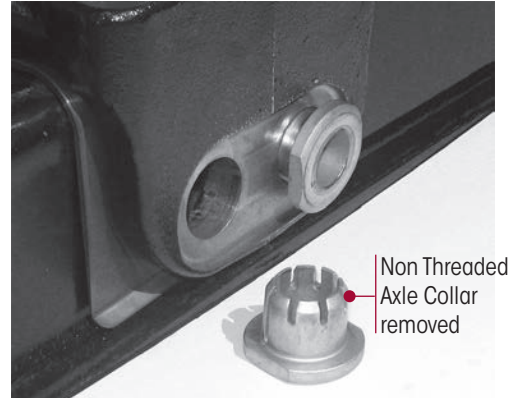

ASSEMBLY



WARNING

WHEN PLACING THE LEAF SPRING AND CLAMP GROUP ASSEMBLY IN A VISE IT IS NECESSARY TO PROTECT THE MACHINED SURFACES FROM GOUGES OR MARRING BY USING BRASS JAWS (SOFT JAWS) SEE FIGURE 9-12. FAILURE TO DO SO CAN CAUSE PREMATURE PART DAMAGE, DAMAGE TO THE LEAF SPRING AND CLAMP GROUP ASSEMBLY, LOSS OF WARRANTY, LOSS OF VEHICLE CONTROL, CAUSING PERSONAL INJURY OR PROPERTY DAMAGE.

SERVICE HINT

It is acceptable to mount the leaf spring and clamp group components in a soft jaw vise or work bench when performing the following tightening procedure.

1. Secure the leaf spring and clamp group assembly in a suitable holding device, such as a vise with brass jaws (soft jaws) or on a workbench, see Figure 9-12.
2. Ensure the clamp group hex bolts are tightened to 600 ± 60 foot pounds torque in 100 pound increments in the proper pattern to achieve uniform bolt tension, see Figure 9-13.

FIGURE 9-12

Leaf Spring and Clamp Group Assembly

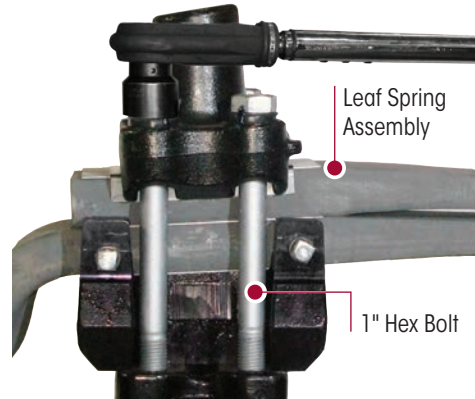
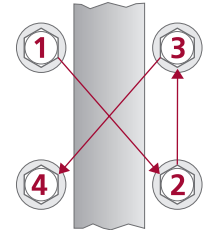

FIGURE 9-13



3. Install the new axle seat liner under the axle seat (liner ear snap to side of axle seat), see Figure 9-14.



WARNING

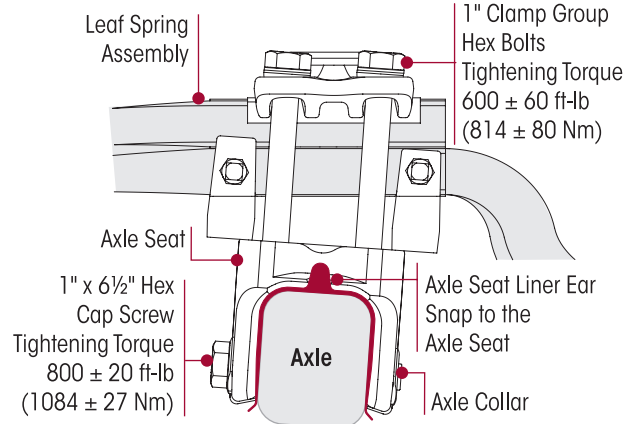

THE WEIGHT OF THE LEAF SPRING AND CLAMP GROUP ASSEMBLY IS APPROXIMATELY 250 POUNDS. CARE SHOULD BE TAKEN AT REMOVAL AND INSTALLATION TO PREVENT PERSONAL INJURY OR DAMAGE TO COMPONENTS.

FIGURE 9-14

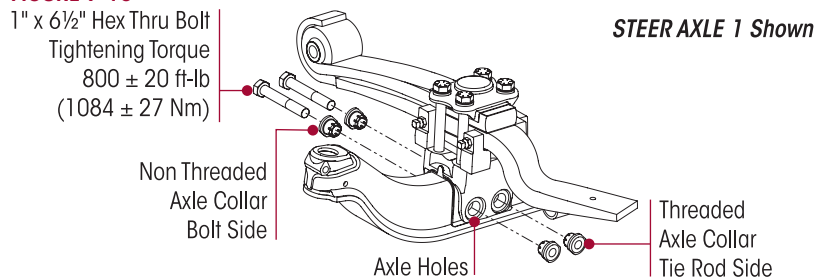
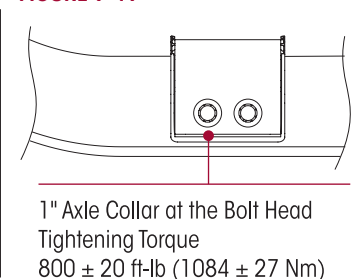

4. Install the new leaf spring and clamp group assembly (approximate weight 250 pounds) on the axle. Ensure the axle seat liner holes are lined up with the axle seat and axle holes, see Figures 9-14.
5. Install the non-threaded collars at the **BOLT SIDE** of the axle and the threaded collars at the **TIE ROD SIDE** of the axle going into the axle seat, axle seat liner and axle. Tap into place with a mallet, see Figure 9-15.
6. Install the axle collar bolts, see Figure 9-16, of the axle and snug fastener. **DO NOT** tighten to torque at this time.
7. Raise the axle.
8. Install thrust washers on leaf spring.
9. Install the leaf spring assembly into the front hanger.

FIGURE 9-16**FIGURE 9-17**

10. Install the QUIK-ALIGN fasteners. **DO NOT** torque at this time.
11. Install the axle bracket, refer to Axle Bracket in this section.
12. Install the air spring, refer to Air Spring in this section.
13. Raise the axle and the leaf spring clamp group assembly.
14. Install the lower shock absorber bolt from the outboard side of the leaf spring shock absorber mount. Install the outboard spacer, inboard spacer and locknut and tighten fasteners to  188 ± 13 foot pounds torque.
15. Tighten both sides, left and right of the axle collar bolts in four stages, (stage one: 100 foot pounds), (stage two: 350 foot pounds), (stage three 700 foot pounds) and (stage four:  800 ± 20 foot pounds final torque), see Figure 9-17.
16. Raise the vehicle to ride height.
17. Tighten QUIK-ALIGN fasteners to  850 ± 20 foot pounds.
18. Install the tires per the vehicle manufacturer's specifications.
19. Remove the safety stands and load the front axle with the vehicle weight.
20. Remove the wheel chocks.

LEAF SPRING & CLAMP GROUP ASSEMBLY – Components

These leaf spring and clamp group assembly instructions can be used to replace individual components shown in Figure 9-18.

You will need:

- Soft Jaw Vice

DISASSEMBLY

1. Remove the leaf spring and clamp group assembly module as shown in this section.
2. Remove and discard the four (4) 1" x 8" clamp group hex bolts, flat and spherical washers that secure the clamp group, see Figure 9-18.
3. Prior to removal note the top pad orientation. Remove the top pad.
4. Remove and discard leaf spring liner.



5. Loosen the jam nuts and back off the set screws, see Figure 9-18.
6. Use a suitable lifting device to pivot the leaf spring assembly off the bottom cap.
7. Lift the bottom cap off of axle seat and remove dowel pins if necessary.



THE WEIGHT OF THE LEAF SPRING AND CLAMP GROUP ASSEMBLY ARE APPROXIMATELY 250 POUNDS. CARE SHOULD BE TAKEN AT REMOVAL AND INSTALLATION TO PREVENT PERSONAL INJURY, OR DAMAGE TO THE COMPONENTS.

8. Remove and discard the axle seat liner.

ASSEMBLY

1. Install the new axle seat liner under the axle seat (liner ear snap to side of axle seat), see Figure 9-19.
2. If necessary, insert the dowel pins into the bottom cap. Ensure the dowel pins are fully seated into the bottom cap.
3. Install the bottom cap onto the axle seat in the same orientation prior to removal, see Figure 9-19.
4. Lower and pivot the rear leaf spring assembly until it engages into the bottom cap. Ensure the assembly is fully seated into the bottom cap.
5. Install the new leaf spring liner on top of the leaf spring assembly.
6. Install the top pad in the same orientation as prior to removal.
7. Install the washers, spherical washers onto the top pad, see Figure 9-18.

FIGURE 9-18

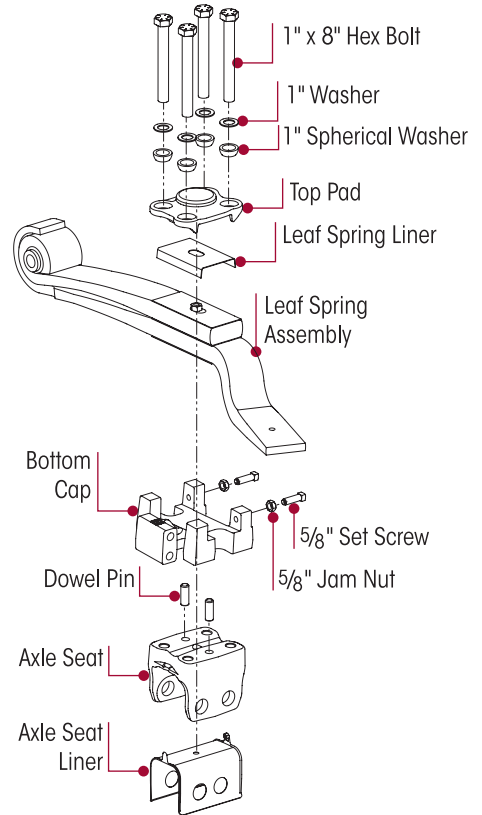

FIGURE 9-19

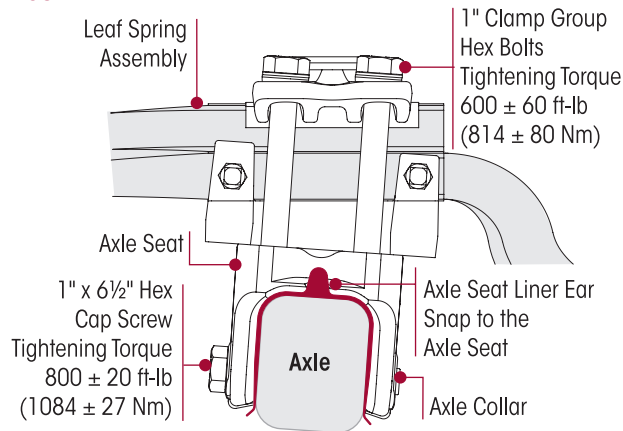
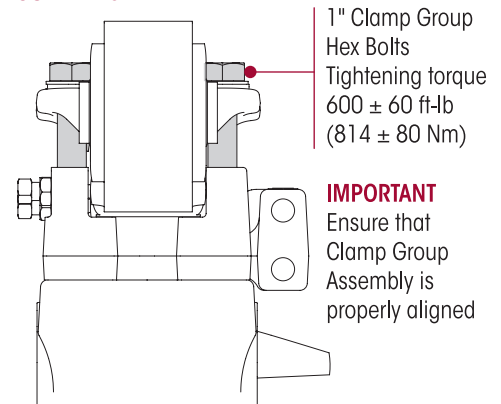
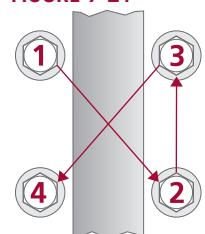

FIGURE 9-20



8. Install the hex bolts through the top pad and into the axle seat and snug. **DO NOT** tighten at this time, see Figure 9-20.
9. Tighten the 1" clamp group hex bolts evenly in 200 foot pound increments to \mathbb{R} 600 ± 60 foot pounds torque in the proper pattern to achieve uniform bolt tension, see Figure 9-21.
10. Tighten the set screws and jam nuts to \mathbb{R} 50 ± 10 foot pounds torque, see Figure 9-18.

FIGURE 9-21



11. Install the thrust washers onto the leaf spring assembly onto the frame hanger.
12. Install leaf spring & clamp group assembly module as shown in this section.
13. Install the air spring, refer to Air Spring in this section.
14. Install the axle bracket, refer to Axle Bracket in this section.
15. Install the wheel assemblies per the vehicle manufacturer's instructions.
16. Remove the axle safety stands and lower the axle.
17. Remove the frame safety stands and load the front axle with the vehicle weight.
18. Remove the wheel chocks.

STEERTEK NXT HIGH-CAPACITY AXLE

AXLE REMOVAL

1. Place the vehicle on level floor.
2. Chock the wheels.

WARNING

DO NOT USE A TORCH ON AXLE COLLAR FASTENERS OR ANY OTHER PART OF THE STEERTEK NXT HIGH-CAPACITY STEER AXLE SYSTEM. THE USE OF A TORCH CAN CAUSE DAMAGE TO CERTAIN STEERTEK NXT HIGH-CAPACITY COMPONENTS THAT CAN RESULT IN THE LOSS OF VEHICLE CONTROL, AND POSSIBLE PERSONAL INJURY, OR PROPERTY DAMAGE.

3. Raise the frame.
4. Support the vehicle with safety stands
5. Suspend the front axle with the shock absorbers attached.
6. Remove the front wheels assemblies per the vehicle manufacturer's instructions.
7. Disconnect the drag link from the steering arm.
8. Support the axle with a safety stands.

WARNING

DO NOT REPAIR OR RECONDITION SUSPENSION OR AXLE COMPONENTS FOUND TO BE DAMAGED OR OUT OF SPECIFICATIONS. ALL SUCH DAMAGED OR OUT OF SPECIFICATION COMPONENTS MUST BE REPLACED. ALL MAJOR HENDRICKSON COMPONENTS ARE HEAT TREATED AND TEMPERED. AIRTEK NXT COMPONENTS CANNOT BE BENT, WELDED, HEATED, OR REPAIRED WITHOUT REDUCING THE STRENGTH OR LIFE OF THE COMPONENT. FAILURE TO FOLLOW THESE GUIDELINES CAN CAUSE LOSS OF VEHICLE CONTROL, AND POSSIBLE PERSONAL INJURY OR DEATH OR PROPERTY DAMAGE AND WILL VOID APPLICABLE WARRANTIES.

9. Remove the 1" axle collar bolts and collars, refer Leaf spring and Clamp Group Module Disassembly.
10. Lower the axle and remove from the vehicle.

AXLE INSTALLATION



1. Place the new axle assembly on the floor jack and position the axle under the vehicle, see Figure 9-22.
2. Install the new axle seat liner under the axle seat (liner ear snap to the side of the axle seat).
3. Raise the axle into position.
4. Ensure the axle seat liner holes are lined up with the axle seat and axle holes, see Figure 9-22.
5. Install the new axle collar fasteners with the bolt head located on the front side of the axle.
6. Tighten both sides, left and right of the axle collar bolts in four stages, stage one 100 foot pounds, stage two 350 foot pounds, stage three 700 foot pounds and the fourth and final  800 ± 20 foot pounds torque, see Figure 9-22.
7. Install the steering knuckles, refer to the Steering Knuckle installation instructions in this section.
8. Install the tie rod assembly into the tie rod arms.



FIGURE 9-22

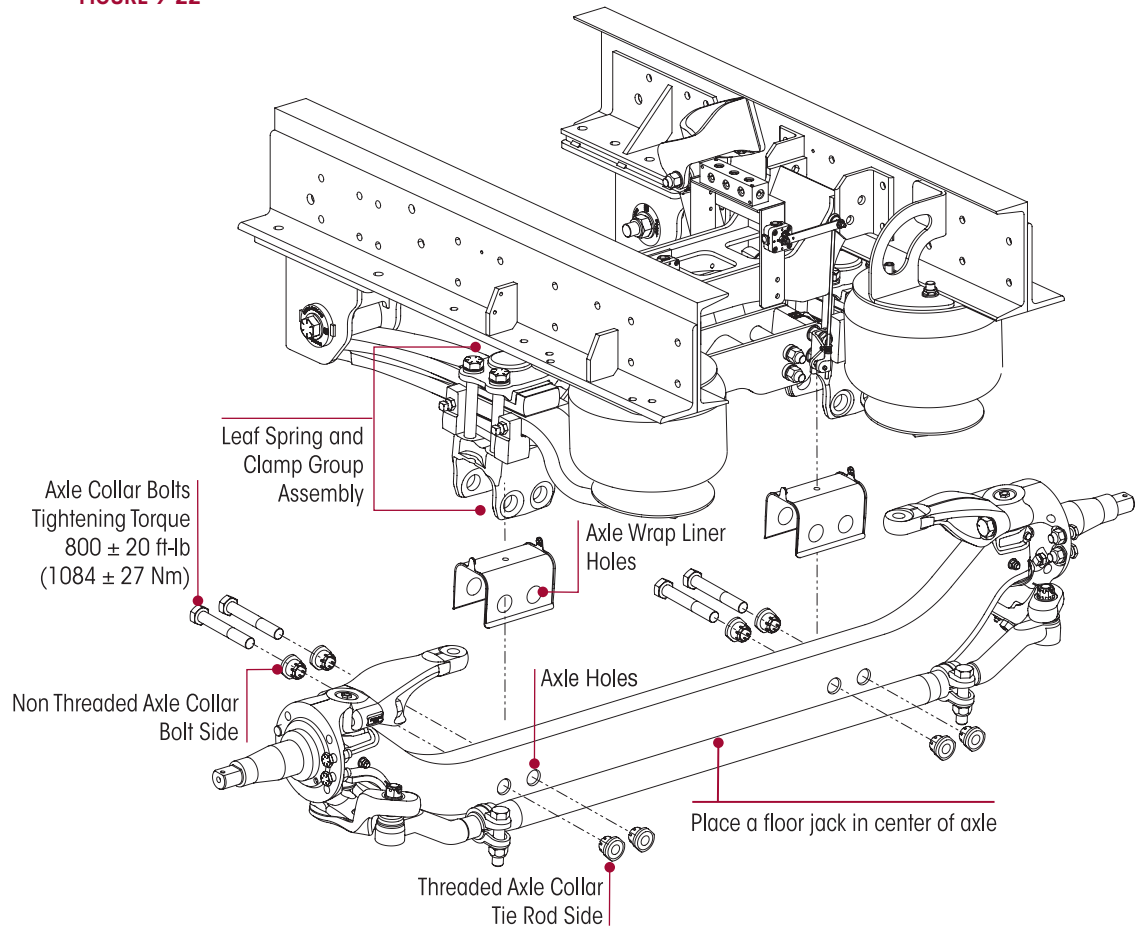

9. Install the $\frac{7}{8}$ " washers on the tie rod arms and the castle nuts. Tighten the castle nuts to  185 foot pounds, then rotate until the first castle slot lines up with the cotter pin bore in the tie rod end. **DO NOT** back off nut for cotter pin installation.
10. Install the tie rod end cotter pin.
11. Connect the drag link in the steering arm.
12. Install the castle nut on the drag link taper stud as per vehicle manufacturer's instructions. **DO NOT** back off nut for cotter pin installation.
13. Install the drag link cotter pin.
14. Install the torque plate assemblies and ABS sensors and torque all fasteners per manufacturer's specifications.
15. Install the wheel assemblies per the vehicle manufacturer's instructions.
16. Raise the vehicle and remove the safety stands.
17. Lower the vehicle and load the front axle with the truck's weight. Remove the floor jack.
18. Remove the wheel chocks.
19. Fill the hubs with the proper lubricant, (see manufacturer's guidelines for recommended lubrication), if required.
20. Grease the front steering components as per lubrication guidelines in the Preventive Maintenance section on this publication.

STEERING KNUCKLE COMPONENTS

TIE ROD DISASSEMBLY

1. Note the orientation of tie rod arm before removal.
2. Place the vehicle on level floor.
3. Chock the wheels.
4. Support the vehicle with safety stands
5. Raise and support the axle with safety stands.
6. Remove the wheel assemblies per the vehicle manufacturer's instructions.
7. Remove the caliber and brake assembly from steering knuckle per the brake manufacturer's instructions.
8. Remove the hub and rotor assembly as per the component manufacturers listed in the Parts List section of this publication.

FIGURE 9-23

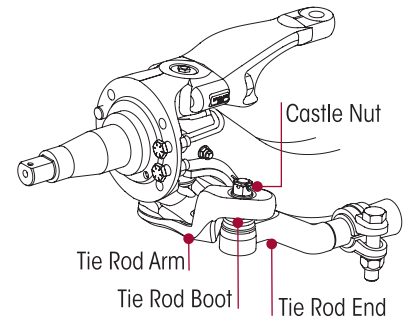

DO NOT USE A PICKLE FORK STYLE TOOL TO SEPARATE THE TIE ROD END FROM THE TIE ROD ARM. DOING SO WILL RESULT IN DAMAGE TO THE GREASE BOOT.

9. Use a 7/8"-14 tie rod end removal tool to separate the tie rod end from the tie rod arm, see Figures 9-23 and 9-24.
10. Disconnect the tie rod assembly from the tie rod arms, see Figures 9-23 and 9-24.
11. Remove the tie rod assembly.

FIGURE 9-24

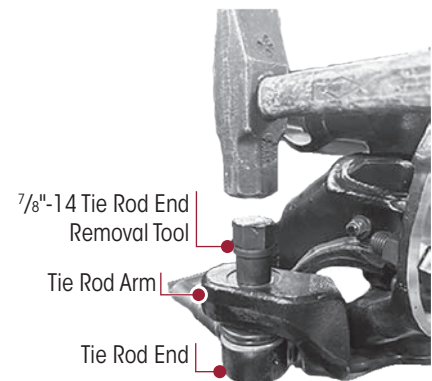

STEERING ARM DISASSEMBLY

1. Remove the two steering arm hex bolts from the knuckle assembly. Figure 9-25.

FIGURE 9-25

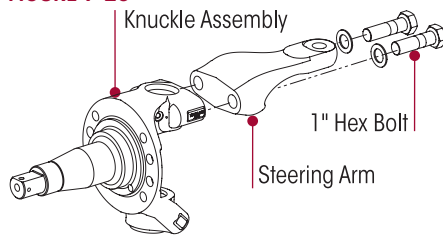

2. Remove the steering arm from the knuckle assembly. If necessary, use a leather or plastic mallet to tap the outside of the arm and separate the arm from the knuckle assembly.
3. Remove the steering arm.
4. Inspect the steering arm for cracks or damage, replace as necessary.



TIE ROD ARM DISASSEMBLY

SUPPORT THE TIE ROD ASSEMBLY DURING MAINTENANCE AND SERVICE TO PREVENT SERIOUS PERSONAL INJURY AND DAMAGE TO COMPONENTS.



DO NOT HEAT THE TIE ROD ARM TO REMOVE THE TIE ROD ASSEMBLY. HEATING THE TIE ROD ARM WILL SOFTEN PARTS AND DAMAGE TO COMPONENTS WILL RESULT.

1. Remove and discard tie rod arm 7/8" fasteners.
2. Remove the tie rod arms, see Figure 9-26.

FIGURE 9-26

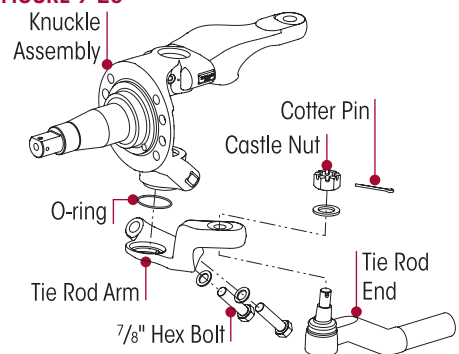



DRAW KEY, KINGPIN AND SHIM DISASSEMBLY

You will need:

- Brass drift and hammer,
 - Heavy-duty kingpin press that can generate 46,000 lb of force and will accommodate 2" kingpins
1. Remove the top grease cap.
 2. Remove the draw keys.
 - a. Loosen the threaded draw key locknut until the top of the locknut is even with the end of the draw key, see Figure 9-27.
 - b. Use a brass drift and a hammer to hit the end of the draw key.
 - c. Remove and discard the nut from the draw key. Remove the draw key from the knuckle.
 3. **If not replacing the kingpin bushings**, use the following procedure to help prevent damage to the bushings during kingpin removal.
 - a. Use a brass drift and a hammer to remove the kingpins from the knuckle, see Figure 9-28.
 - b. Remove any flaring on the drift that touches the bushings.
 - c. Wrap tape to a thickness of 1/16" (1.5 mm) onto the end of the drift.
 4. If the kingpin is difficult to remove, use a hydraulic kingpin remover.
 5. Remove the steering knuckle from the axle.



WARNING

WEAR GLOVES WHEN REMOVING OR INSTALLING SHIMS. SHIMS HAVE SHARP EDGES THAT CAN CAUSE SERIOUS PERSONAL INJURY.

6. While wearing gloves, remove the shims and thrust bearing from the axle and/or steering knuckle, see Figure 9-29.
7. Inspect the parts, refer to the Preventive Maintenance section in this publication.

FIGURE 9-26

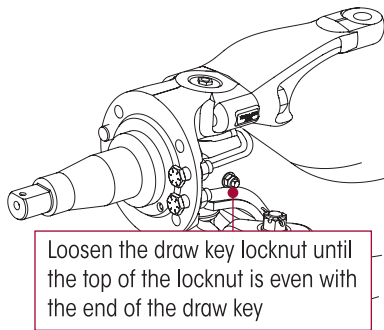

FIGURE 9-28

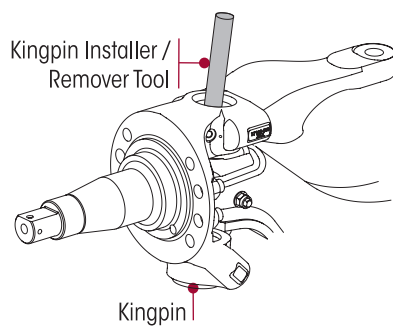
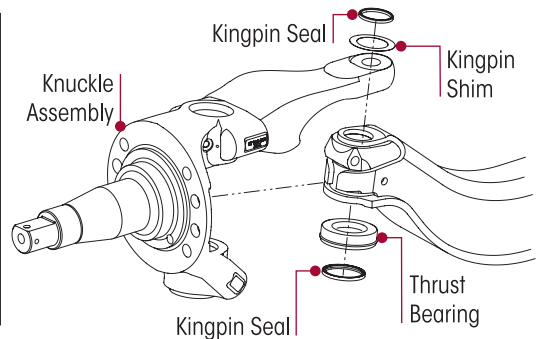

FIGURE 9-29



KINGPIN BUSHING

You will need:

- Kingpin bushing driver and installer/remover tool, refer to the Special Tools section of this publication.

REMOVAL

1. Place the steering knuckle on a workbench squarely supported.
2. Place the STEERTEK NXT high-capacity kingpin bushing installer/remover tool in the steering knuckle/kingpin bore, see Figure 9-30.
3. Remove the kingpin seal.
4. Use a hammer and drive out the kingpin bushing, see Figure 9-31.
5. Rotate the knuckle over and repeat Steps 1-4 to remove the other kingpin bushing.

6. Clean the knuckle kingpin bores with a rotary wire wheel and inspect for reassembly, see Figure 9-32.

FIGURE 9-30

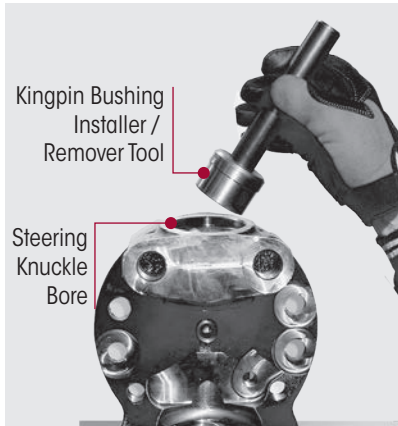

FIGURE 9-31



FIGURE 9-32



STEERING KNUCKLE BORE MEASUREMENT

Complete the following steering knuckle bore inspection and the measurement instructions prior to installing the kingpin bushing.

1. Measure the upper steering knuckle bore inside diameter at two locations. Always use an inside micrometer or a telescoping gauge when taking a knuckle bore measurement. Some out-of-roundness at the top and bottom of the bore edges is acceptable. Steering knuckle bore diameter specification is $2.127" \pm 0.002"$.
2. Measure the upper and lower bore in two positions and at two locations. The two positions must be 90° opposed from each other, see Figures 9-33 through 9-35. If the average measurement is more than the knuckle bore maximum diameter specification, replace the knuckle.

FIGURE 9-33

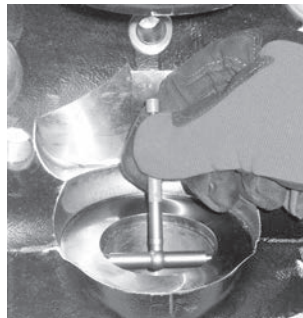

FIGURE 9-34

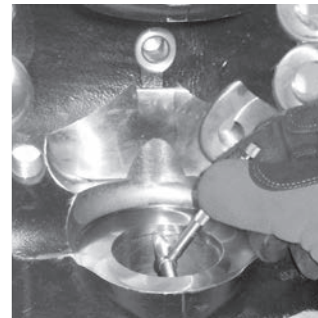
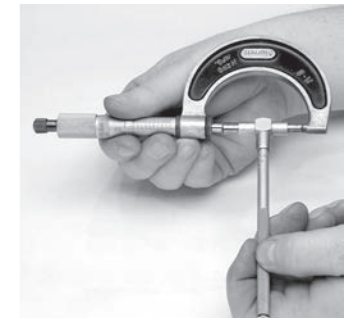

FIGURE 9-35



INSTALLATION

1. Install the kingpin bushings from the axle side of the steering knuckle.
2. Place the new kingpin bushing into the steering knuckle bore so the seam **DOES NOT** align with the grease channel, see Figures 9-36 and 9-37.
3. Use the kingpin bushing driver to install the kingpin bushing into the steering knuckle bore, see Figure 9-38. Continue installation until the kingpin bushing is flush with the machined surface of the steering knuckle.
4. Remove the kingpin bushing driver.
5. Install the kingpin bushing installer/remover tool.
6. Continue driving the kingpin bushing into the steering knuckle until it is flush with the bottom of kingpin seal bore, see Figures 9-39 and 9-40.
7. Repeat steps for the remaining kingpin bushing.
8. Ream or hone the bushings, see Reaming • Honing procedure in this section.



FIGURE 9-36

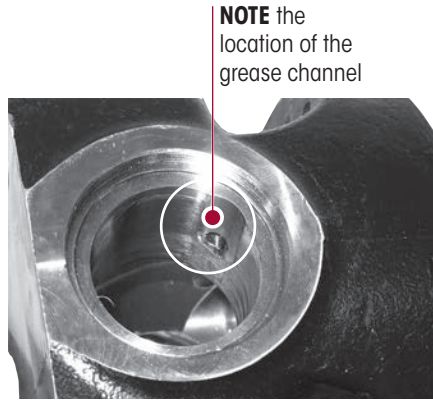

FIGURE 9-37

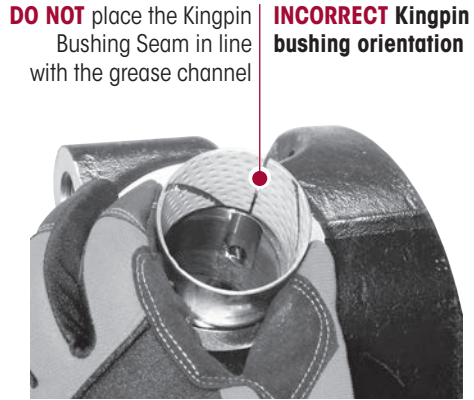

FIGURE 9-38



FIGURE 9-39



FIGURE 9-40

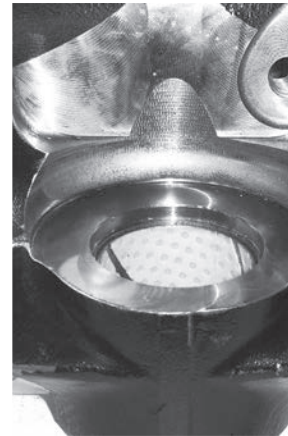

KINGPIN PREPARATION AND MEASUREMENT

Cleaning Ground and Polished Parts

- Use a cleaning solvent to clean ground or polished parts and surfaces. **DO NOT USE GASOLINE.**
- **DO NOT** clean ground or polished parts in a hot solution tank or with water, steam, or alkaline solutions. These solutions will cause corrosion of the parts.

Drying the Cleaned Parts – Parts must be dried immediately after cleaning. Dry the parts with clean paper towels, clean rags, or compressed air. **DO NOT** dry bearings by spinning with compressed air. Damage to the bearings will result.

Preventing Corrosion on Cleaned Parts – Apply a light coating of oil to all cleaned and dried parts that are going to be reused. **DO NOT** apply oil to the brake lining or the brake drums. If parts are to be stored, apply an effective rust inhibitor to all surfaces.



SOLVENT CLEANERS CAN BE FLAMMABLE, POISONOUS AND CAUSE BURNS. TO HELP AVOID SERIOUS PERSONAL INJURY, CAREFULLY FOLLOW THE MANUFACTURER'S PRODUCT INSTRUCTIONS AND GUIDELINES AND THE FOLLOWING PROCEDURE:

1. WEAR PROPER EYE PROTECTION
2. WEAR CLOTHING THAT PROTECTS YOUR SKIN
3. WORK IN A WELL VENTILATED AREA
4. DO NOT USE GASOLINE, OR SOLVENTS THAT CONTAIN GASOLINE. GASOLINE CAN EXPLODE
5. ACIDIC SOLUTIONS CANNOT BE USED ON ALUMINUM COMPONENTS
6. HOT SOLUTION TANKS OR ALKALINE SOLUTIONS MUST BE USED CORRECTLY. FOLLOW THE MANUFACTURER'S RECOMMENDED INSTRUCTIONS AND GUIDELINES CAREFULLY TO HELP PREVENT PERSONAL ACCIDENT OR INJURY

DO NOT USE HOT SOLUTION TANKS OR WATER AND ALKALINE SOLUTIONS TO CLEAN GROUND OR POLISHED PARTS. DOING SO WILL CAUSE DAMAGE TO THE PARTS AND VOID ANY APPLICABLE WARRANTY.

WARNING

TO HELP PREVENT SERIOUS EYE INJURY, ALWAYS WEAR PROPER EYE PROTECTION WHEN YOU PERFORM VEHICLE MAINTENANCE OR SERVICE.

1. Inspect the kingpin for wear or damage.
2. Use a micrometer and measure the kingpin. If the kingpin has less than 2.0" diameter, replacement is necessary, see Figure 9-41. **Kingpin minimum dimension is 2.0"**

FIGURE 9-41

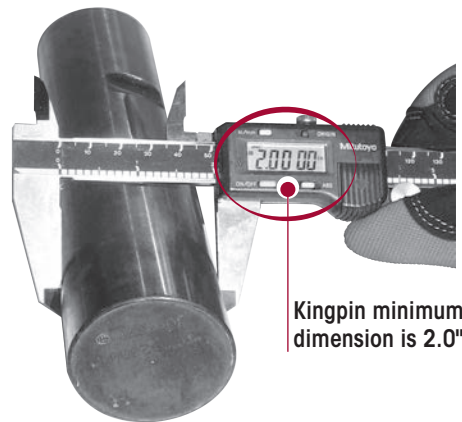
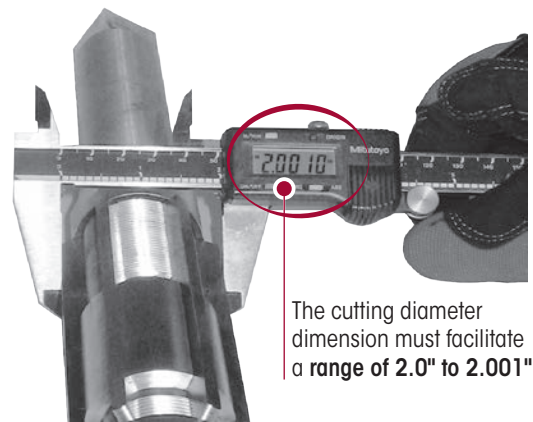

FIGURE 9-42



KINGPIN BUSHING REAMING • HONING PROCEDURE

Once new replacement kingpin bushings are installed, they will need to be properly sized to fit the respective kingpins using one of the following two methods:

- **Method A – Reaming** or **Method B – Honing**

NOTE

Bushing inner diameter size is to be 0.001" larger than the measured kingpin outer diameter size.

CAUTION

DO NOT BURNISH THE KINGPIN BUSHINGS. BURNISHING WILL DAMAGE THE BUSHINGS AND VOID ANY APPLICABLE WARRANTY.

WARNING

WHEN INSTALLING STEERING KNUCKLE COMPONENTS IN A VISE IT IS NECESSARY TO PROTECT THE MACHINED SURFACES FROM GOUGES OR MARRING BY USING BRASS JAWS. FAILURE TO DO SO CAN CAUSE PREMATURE PART DAMAGE, DAMAGE TO THE STEERING KNUCKLE COMPONENTS, LOSS OF WARRANTY, LOSS OF VEHICLE CONTROL, CAUSING PERSONAL INJURY OR PROPERTY DAMAGE.

WARNING

PRIOR TO INSTALLATION ENSURE THAT ALL RESIDUAL LOCTITE® MATERIAL IS REMOVED FROM THE MOUNTING BOLTS AND THE THREAD BORES IN THE UPPER STEERING KNUCKLES, AND NEW LOCTITE 277 OR EQUIVALENT IS APPLIED TO HELP ENSURE THAT THE BOLTS SUSTAIN THE PROPER TORQUE REQUIREMENT. FAILURE TO DO SO CAN CAUSE LOSS OF VEHICLE CONTROL RESULTING IN PERSONAL INJURY OR PROPERTY DAMAGE.

METHOD A: REAMING

NOTE

Prior to reaming the kingpin bushing, re-assemble the steering knuckle.

You will need:

- Adjustable straight flute reamer (McMaster-Carr part no. 3141A28), extension pilot tool (McMaster-Carr part no. 3004A32), and vise with brass jaws (soft jaws), see Parts List section of this publication.
1. Set up the reamer to match kingpin dimension, see Figure 9-42. The dimension of cutting diameter must facilitate a range of 2.0" to 2.001".
 2. Place the steering knuckle in a vise with brass jaws (soft jaws), see Figure 9-43.



3. Install the reamer onto the end of the extension pilot tool and position the extension pilot tool through the kingpin bushing.

SERVICE HINT

The pilot helps keep the reamer straight during the reaming process.

4. Slide the reamer into the steering knuckle until the blades touch the kingpin bushing inner diameter surface.
5. Rotate the reamer with a light **DOWNWARD** pressure. **DO NOT** apply too much force. Rotate the reamer smoothly, see Figures 9-44 and 9-45.

FIGURE 9-43

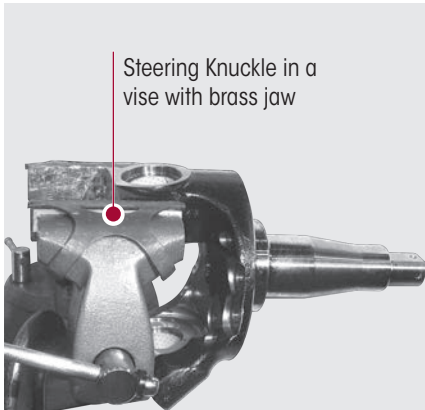

FIGURE 9-44

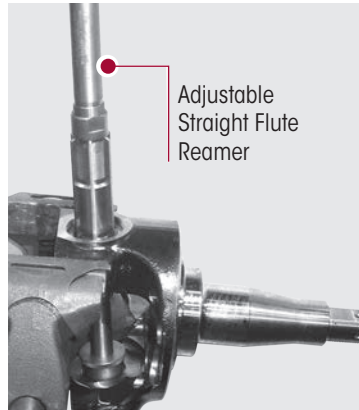
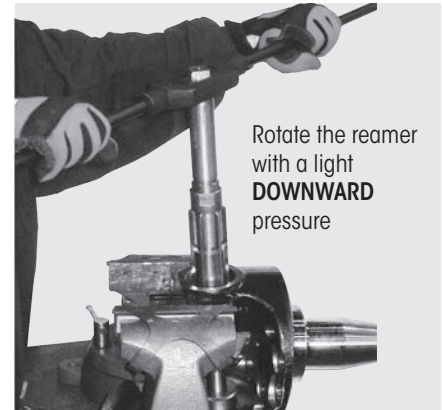

FIGURE 9-45



SERVICE HINT

To remove the reamer, rotate the tool in the opposite cutting direction.

6. Turn the knuckle over in the vise and repeat Steps 1 through 4 for the other kingpin bushing, then remove the steering knuckle from the vise.
7. Disassemble the steering knuckle, then clean and remove all loose kingpin bushing material created by the reaming operation from the steering knuckle(s). Take special attention to remove material from the grease channels and dimples.
8. Clean the 5/8" brake backing plate bolts with a wire wheel and run a tap through the threads of the steering knuckle and then flush out with brake cleaner and dry with compressed air.
9. Lightly lubricate the mating kingpin with penetrating oil.
10. Temporarily install the steering knuckle on the mating kingpin to check for a close slip fit and free rotation.

SERVICE HINT

Prior to assembly of the knuckle to the axle, insert the kingpin into the knuckle to ensure proper reaming or honing of the bushing. The kingpin should slide into the upper and lower kingpin bushings with little to no resistance. If the kingpin does not slide easily repeat the reaming / honing procedure, see Figure 46.

NOTE

If the kingpin does not fit into the kingpin bushing, **DO NOT** force it.

FIGURE 46



11. Rotate the steering knuckle back and forth to verify there is no binding on the kingpin.
12. If either of the kingpin bushings are too tight, repeat steps 1 through 10 until proper clearance is achieved.
13. Proceed to the Kingpin Seal Installation procedure.

METHOD B: HONING

You will need:

- 1 3/4" to 2 3/4" precision-finish cylinder hone (McMaster-Carr part no. 7362A45), see Parts List section of this publication. The cylinder must be manually adjustable.
1. Assemble the cylinder hone with clean, dry honing stones.

SERVICE HINT

If the honing stones are damaged or oily, they should be replaced.

2. Ensure the wiper blocks are clean and dry, see Figure 9-47.
3. Place the steering knuckle (equipped with replacement kingpin bushing(s)) on a work surface.
4. Size the precision cylinder hone slightly smaller than the kingpin bushing inner diameter and insert it into the kingpin bushing, see Figure 9-48.
5. Increase the precision cylinder hone's diameter until there is just enough pressure on the kingpin bushing inner diameter to hold the hone in place.
6. Connect a power drive to the precision cylinder hone, see Figure 9-49.
7. Using the power drive, rotate the precision cylinder hone about ten revolutions in the kingpin bushing. The power drive should rotate at a speed of **less than 30 revolutions per minute (RPM)**.
8. Stop the power drive rotation.
9. Reduce the precision cylinder hone's diameter and remove it from the kingpin bushing.
10. Remove steering knuckle from the work surface. Repeat Steps 1 through 9 for the other steering knuckle.
11. Clean and remove all loose kingpin bushing material created by the honing operation from the steering knuckle. Take special attention to remove material from the grease channels and dimples.
12. Perform Steps 7 through 10 of the Method A – Reaming section.
13. If either of the kingpin bushings are too tight, repeat steps 1 through 12 of the Method B, until proper clearance is achieved.
14. Proceed to Kingpin Seal Installation procedure.

FIGURE 9-47



FIGURE 9-48

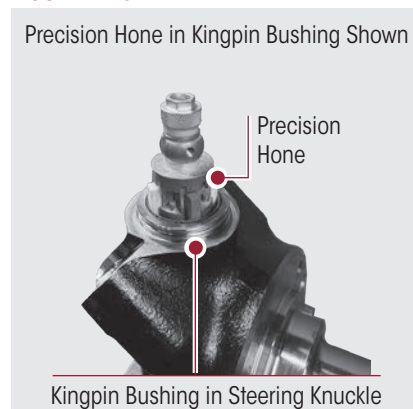

FIGURE 9-49





KINGPIN SEAL INSTALLATION

You will need:

- Kingpin Seal Driver/Remover Tool, refer to the Special Tools section in this publication.
1. Place the steering knuckle assembly on a suitable workbench.
 2. Lay the kingpin seal into the bore of the steering knuckle. Ensure the lip of the kingpin seal faces toward the axle, see Figure 9-50.
 3. Use a kingpin seal Driver/Remover tool and drive the seal firmly into the steering knuckle assembly with a hammer.
 4. Install the kingpin seal until it bottoms out in the kingpin bore, see Figure 9-51.

FIGURE 9-50

Ensure the lip of the Kingpin Seal is facing **towards** the axle



FIGURE 9-51

Kingpin seal bottoms out in the kingpin bore



STEERING KNUCKLE INSTALLATION

1. Clean the kingpin bores of the axle.
2. Install the roller thrust bearing assembly on the inner steering knuckle. The seal must face **UPWARD** toward the beam. The top inner diameter will contact the bottom of the axle, see Figure 9-52.

FIGURE 9-52

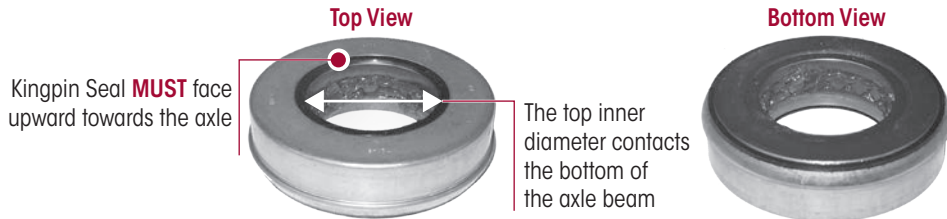

WARNING

WEAR GLOVES FOR SHIM INSTALLATION. SHIMS HAVE SHARP EDGES THAT CAN CAUSE SERIOUS PERSONAL INJURY.

3. Place the knuckle onto the axle, see Figure 9-53.
4. Place a pry bar between the steering arm boss and the axle. Lift the knuckle and slide the shim pack between the top of the beam and the steering knuckle, see Figure 9-54.

FIGURE 9-53

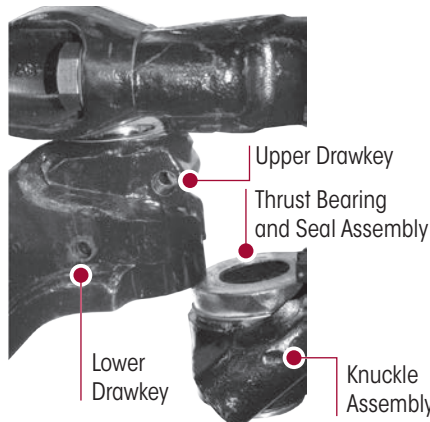
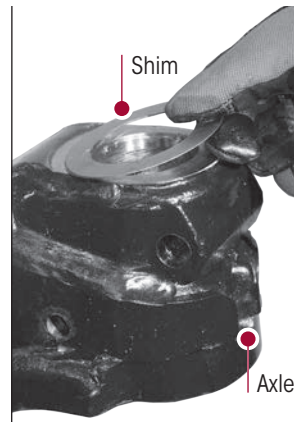

FIGURE 9-54



5. Align all the steering knuckle components within the kingpin bore. If the bores are not aligned, the components will be damaged during kingpin installation.
6. Remove the pry bar.
7. Apply the multi-purpose grease onto the bottom half of the kingpin prior to kingpin installation onto the steering knuckle.

CAUTION

VERIFY THAT THE DRAW KEY IS INSTALLED COMPLETELY OR THE LOCKNUT IS TIGHTENED TO $\boxed{35 \pm 5}$ FOOT POUNDS TORQUE. IF NOT INSTALLED CORRECTLY, THE KINGPIN AND THE AXLE WILL BE DAMAGED.

8. Install the kingpin into the top of the knuckle and through the area where the shims are located, see Figures 9-55 and 9-56. **DO NOT** force the kingpin through the upper kingpin bushing. Ensure the word **TOP** is facing up, see Figure 9-57.
9. Rotate the kingpin and slide in until the two draw key slots align with the axle draw key bores, see Figures 9-56 and 9-57.
10. If required, use a hammer and a brass drift to apply direct force to the kingpin for seating into the lower steering knuckle bore, see Figure 9-55.

FIGURE 9-55

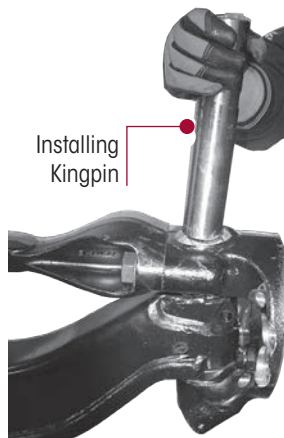

FIGURE 9-56

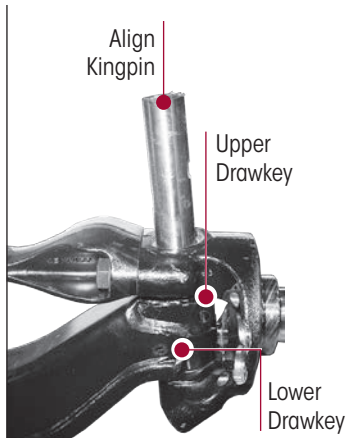
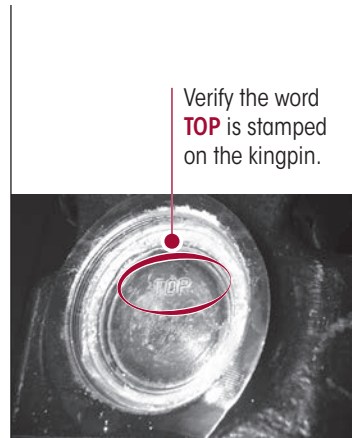

FIGURE 9-57



11. Seat the upper draw key into the **FRONT** of the axle, see Figure 9-59.
12. Seat the lower draw key into the **BACK** of the axle by striking it with a hammer and drift, see Figure 9-58. The draw keys must align with the slots of the kingpin.
13. Install the draw key locknuts, Snug, **DO NOT** tighten to torque until after the steering knuckle vertical end play procedure is completed.

FIGURE 9-58

LOWER DRAW KEY

4 $\frac{3}{4}$ " Draw Key
Part No. 75925-002
Back of the Axle

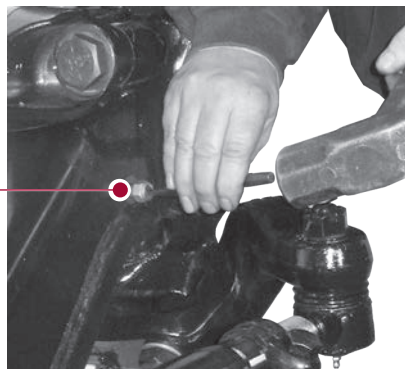
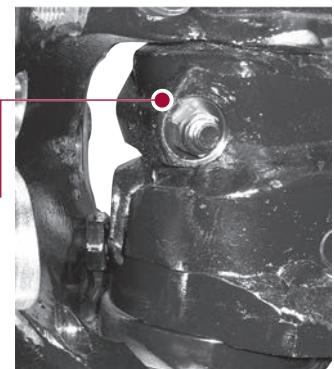

FIGURE 9-59

UPPER DRAW KEY

3 $\frac{3}{8}$ " Draw Key
Part No. 75925-001
Front of the Axle



MEASURE STEERING KNUCKLE VERTICAL END PLAY

1. Turn the knuckle to the straight-ahead position.
2. Attach a magnetic dial indicator base onto the axle. Place the tip onto the top of the steering knuckle, see Figure 9-60.



3. Set the dial indicator to zero.
4. Use one of the following methods to measure the vertical clearance.
 - Place a pry bar between the steering knuckle and the top of the axle center. Pry the steering knuckle up and measure the vertical end play.
 - Place a block of wood and a hydraulic jack under the bottom of the steering knuckle. Raise the steering knuckle until the pointer on the dial indicator stops
5. Record dial indicator reading.
 - If the steering knuckle binds or **zero** end play is measured, remove shims from the shim pack.
 - If the reading is more than the correct specification shown in Table 9-2, add shims to the shim pack.

FIGURE 9-60

Ensure the tip of the dial indicator is on the top of the upper steering knuckle (not on the grease cap)

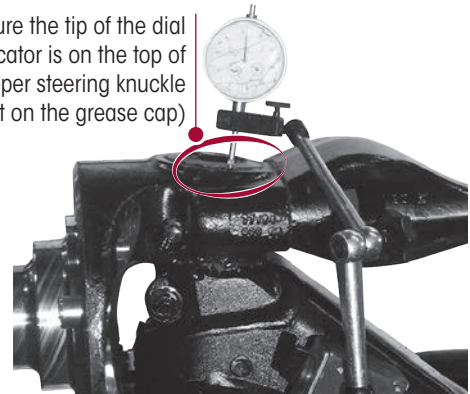

TABLE 9-2

END PLAY SPECIFICATIONS

New or Rebuilt Axles:	0.001"-0.010" (0.025-0.254 mm)	In-service Axles:	0.001"-0.030" (0.025-0.762 mm)
------------------------------	--------------------------------	--------------------------	--------------------------------

6. Tighten the upper and lower draw key locknuts to \mathbb{R} 35 ± 5 foot pounds torque.

GREASE CAP INSTALLATION



TAKE CARE WHEN USING LOCTITE ADHESIVE APPLICATION TO AVOID SERIOUS PERSONAL INJURY. READ THE MANUFACTURER'S INSTRUCTIONS BEFORE USING THIS PRODUCT. FOLLOW THE INSTRUCTIONS CAREFULLY TO PREVENT IRRITATION TO THE EYES AND SKIN. IF LOCTITE® ADHESIVE MATERIAL GETS INTO YOUR EYES, FOLLOW THE MANUFACTURER'S EMERGENCY PROCEDURES. HAVE YOUR EYES CHECKED BY A PHYSICIAN AS SOON AS POSSIBLE.

NOTE

If reusing a grease cap, ensure to apply the Loctite Straight Thread Sealant™ (STS) all around the threads (apply to a minimum of 3 threads), see Figure 9-61.

FIGURE 9-61

Apply Loctite STS to a minimum of three grease cap threads



FIGURE 9-62

Grease Cap Tightening Torque 60 ± 10 ft-lb

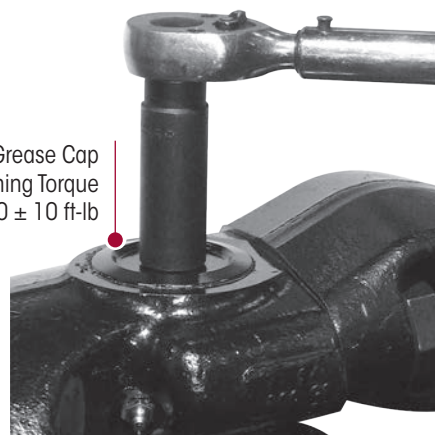

1. Ensure the Loctite STS is applied to a minimum of three grease cap threads (**Note:** New grease caps have Loctite STS pre-applied).
2. Install the threaded grease caps onto the top of the steering knuckle.
3. Tighten the grease caps to \mathbb{R} 60 ± 10 foot pounds, see Figure 9-62.
4. Remove the bottle jack and continue assembling the wheel ends assemblies.

STEERING ARM INSTALLATION

WARNING

TAKE CARE WHEN USING LOCTITE ADHESIVE APPLICATION TO AVOID SERIOUS PERSONAL INJURY. READ THE MANUFACTURER'S INSTRUCTIONS BEFORE USING THIS PRODUCT. FOLLOW THE INSTRUCTIONS CAREFULLY TO PREVENT IRRITATION TO THE EYES AND SKIN. IF LOCTITE® ADHESIVE MATERIAL GETS INTO YOUR EYES, FOLLOW THE MANUFACTURER'S EMERGENCY PROCEDURES. HAVE YOUR EYES CHECKED BY A PHYSICIAN AS SOON AS POSSIBLE.

1. Use a tap to remove old Loctite adhesive from the internal threads of the steering knuckle.
2. Use new steering arm hex bolts and apply Loctite 680 adhesive. Ensure to cover at least half of the thread area.
3. Insert the hex bolts through the steering arm. Hand-start the bolts into the steering knuckle assembly, see Figure 9-63.
4. Tighten the steering arm hex bolts to \mathbb{R} 637 ± 13 foot pounds torque.

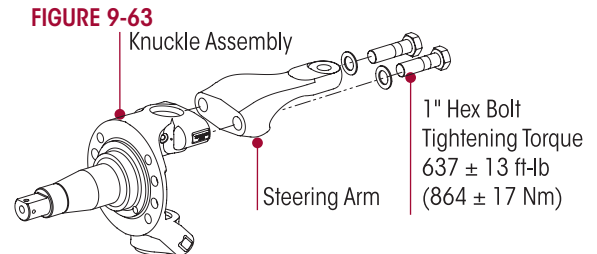
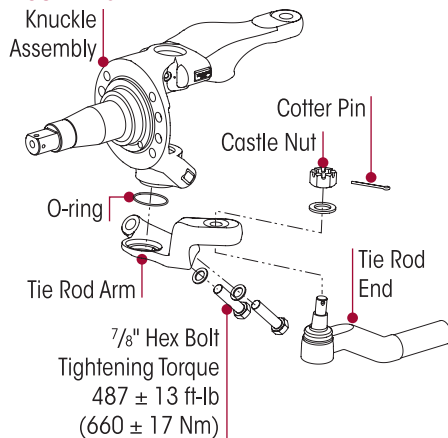

FIGURE 9-64



TIE ROD ARM INSTALLATION

1. Install a new O-ring on the bottom of the steering knuckle.
2. Use a tap to remove old Loctite adhesive from the internal threads of the steering knuckle.
3. Use new tie rod arm hex bolts and apply Loctite 680 adhesive. Ensure to cover at least half of the thread area, see Figure 9-64.
4. Lubricate O-ring with grease and install tie rod arm on the bottom of the steering knuckle.
5. Insert the tie rod arm hex bolts through the tie rod arm and into the steering knuckle. Hand-start the bolts into the steering knuckle assembly, see Figure 9-64.
6. Tighten the tie rod arm bolts to \mathbb{R} 487 ± 13 foot pounds torque.
7. Install the tie rod end into the tie rod arm, see Figure 9-64.
8. Tighten the castle nuts to \mathbb{R} 185 foot pounds torque then rotate the castle nut to the next castle slot and install cotter pin, see Figure 9-64.
9. Install the brake torque plate.

IMPORTANT NOTE

It is critical to apply Loctite to the three brake torque plate bolts to ensure that these bolts sustain the proper torque requirement of steering knuckle assembly.

10. Apply Loctite Red 262 to the torque plate bolts prior to installation into the torque plate.
11. Tighten the torque plate bolts to \mathbb{R} 400 ± 50 foot pounds torque.
12. Install the caliber and brake assembly on steering knuckle per the brake manufacturer's instructions.
13. Install the drag link into the steering arm and tighten to the vehicle manufacturer's specifications.
14. Install wheels and tires.
15. Remove jack and safety stands.
16. Grease steering knuckles with the vehicle on the floor.
17. Remove the wheel chocks.



TIE ROD ENDS AND CROSS TUBE

You will Need:

- 7/8" -14 tie rod end removal tool

DISASSEMBLY

1. Chock the wheels.
2. Position the steer axle tires straight ahead.



DO NOT USE A CROW BAR, PICKLE FORK, OR 2 X 4 TO REMOVE THE TIE ROD ENDS OR THE TIE ROD ASSEMBLY WHICH CAN CAUSE DAMAGE TO COMPONENTS.

3. Remove the cotter pin and castle nut, see Figure 9-65.
4. Use a 7/8" -14 tie rod end removal tool (see Figure 9-63) to separate the tie rod end from the tie rod arm, see Figure 9-65.

FIGURE 9-65

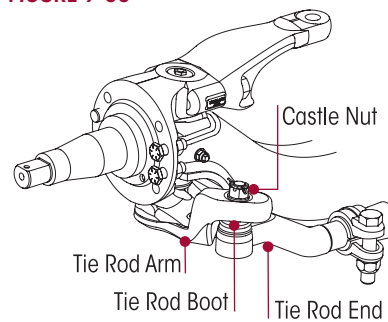

FIGURE 9-66

7/8" -14 Tie Rod End Removal Tool



5. Repeat Steps 3 and 4 to remove the other tie rod end to remove the tie rod assembly.
6. Remove the tie rod assembly from the vehicle.
7. Mount the cross tube in a soft jaw vice.
8. Remove the tie rod clamp hardware from the cross tube.
9. Count the exposed threads on the tie rod end being replaced.



DO NOT HEAT THE CROSS TUBE WITH A TORCH TO FACILITATE THE REMOVAL OF THE TIE ROD END. THE USE OF SUCH HEAT CAN ADVERSELY AFFECT THE STRENGTH OF THE CROSS TUBE. A COMPONENT DAMAGED IN THIS MANNER WILL RESULT IN LOSS OF WARRANTY, AND CAN RESULT IN THE AND LOSS OF VEHICLE CONTROL, AND POSSIBLE PERSONAL INJURY OR PROPERTY DAMAGE.

10. Remove the tie rod end from the cross tube.
11. If the opposing tie rod end is being replaced repeat Steps 8 through 10.
12. Inspect the cross tube for dents, cracks, or thread damage, replace as necessary.

ASSEMBLY

1. Lubricate the new tie rod end threads with anti-seize.

NOTE

When installing the cross tube the thread direction of the tie rod ends are as follows:

- A right hand threaded tie rod end will be installed into the right side tie rod arm.
- A left hand threaded tie rod end will be installed into the left side tie rod arm.

2. Install the new tie rod end into the cross tube, leaving the same amount of threads exposed that were counted on the removed tie rod end.





THE THREADED PORTION OF THE TIE ROD END MUST EXTEND PAST THE SLOTS INTO THE TIE ROD CROSS TUBE, SEE FIGURE 9-67. FAILURE TO DO SO CAN CAUSE COMPONENT DAMAGE, LOSS OF VEHICLE CONTROL AND POSSIBLE PERSONAL INJURY OR PROPERTY DAMAGE.

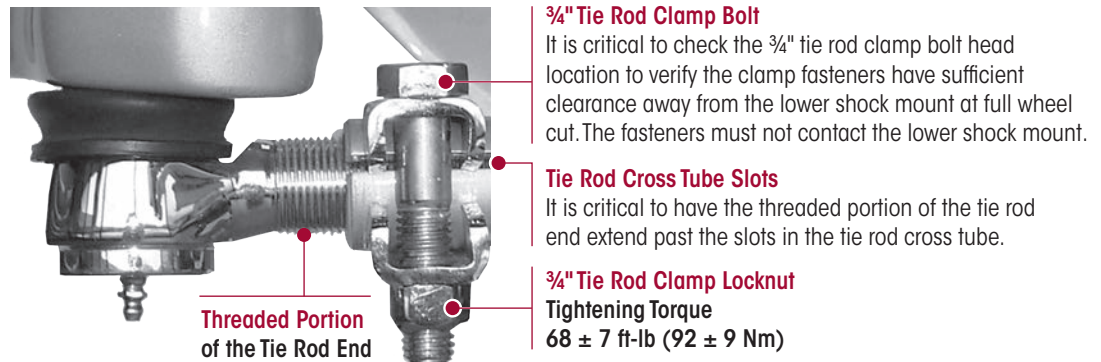

IT IS CRITICAL TO CHECK THE 3/4" TIE ROD CLAMP BOLT HEAD LOCATION TO VERIFY THE CLAMP FASTENERS HAVE SUFFICIENT CLEARANCE AWAY FROM THE LOWER SHOCK MOUNT AT FULL WHEEL CUT. THE FASTENERS MUST NOT CONTACT THE LOWER SHOCK MOUNT. FAILURE TO DO SO CAN CAUSE ONE OR MORE COMPONENTS TO FAIL CAUSING LOSS OF VEHICLE CONTROL AND POSSIBLE PERSONAL INJURY OR PROPERTY DAMAGE.

FIGURE 9-67



3. If replacing the opposing tie rod end is not necessary, it is critical that the ball and socket are free to rotate in the opposing tie rod end.
4. Replace the opposing tie rod end if necessary, by repeating Steps 1 and 2.
5. Install both tie rod ends into the tie rod arms.
6. Tighten the castle nuts to  185 foot pounds torque, then rotate the castle nut to the next castle slot and install cotter pin.
7. Grease the tie rod ends with the specified lubricant, see lubrication specifications and procedure in the Preventive Maintenance section of this publication.
8. Set the toe, refer to the Toe Adjustment procedure in the Alignment & Adjustments section in this publication.
9. Remove the wheel chocks.

WHEEL END AND AIR DISC BRAKE ASSEMBLIES AND COMPONENTS

NOTE

Wheel end hubs, seals, bearing cones, hub caps, as well as air disc brake assemblies and components are installed by Hendrickson for new production assembly but these components are not supplied by Hendrickson for aftermarket service purposes. For more information and assistance with service, maintenance and rebuild instructions on these items see the below listed component manufacturers. Refer to the Parts Lists section of this publication for additional information on such assemblies and components.

- **ConMet** 800.547.9473 or www.conmet.com
- **DRiV Incorporated** 800-325-8886 or www.drivparts.com
- **Meritor** 888.725.9355, or www.meritorpartsexpress.com (parts), www.meritorbullpen.com (technical support)
- **WABCO-ZF Friedrichshafen** 855.228.3203 or www.wabco-customercentre.com



SECTION 10 Plumbing Diagram

NOTE

Common example configuration shown. Contact vehicle manufacturer for specific plumbing requirements.

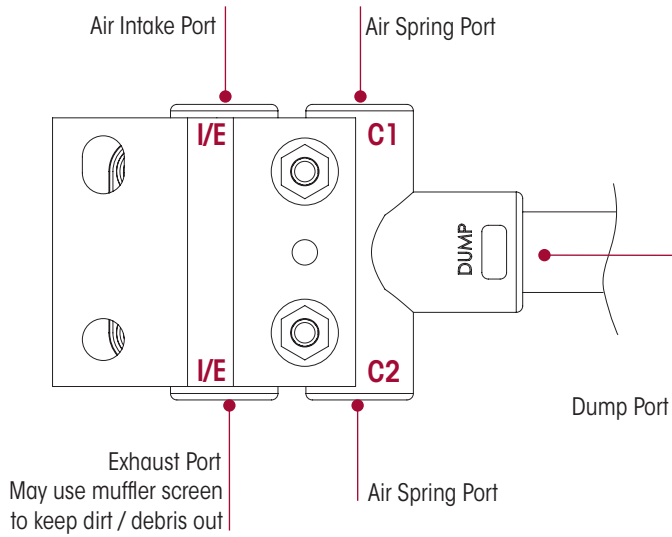

SECTION 11 Torque Specifications

Hendrickson Recommended Torque Values Provided
in Foot Pounds and In Newton Meters

Twin Steer • 7.2" Ride Height

Twin Steer Axle 1 Shown
Front Forward Axle

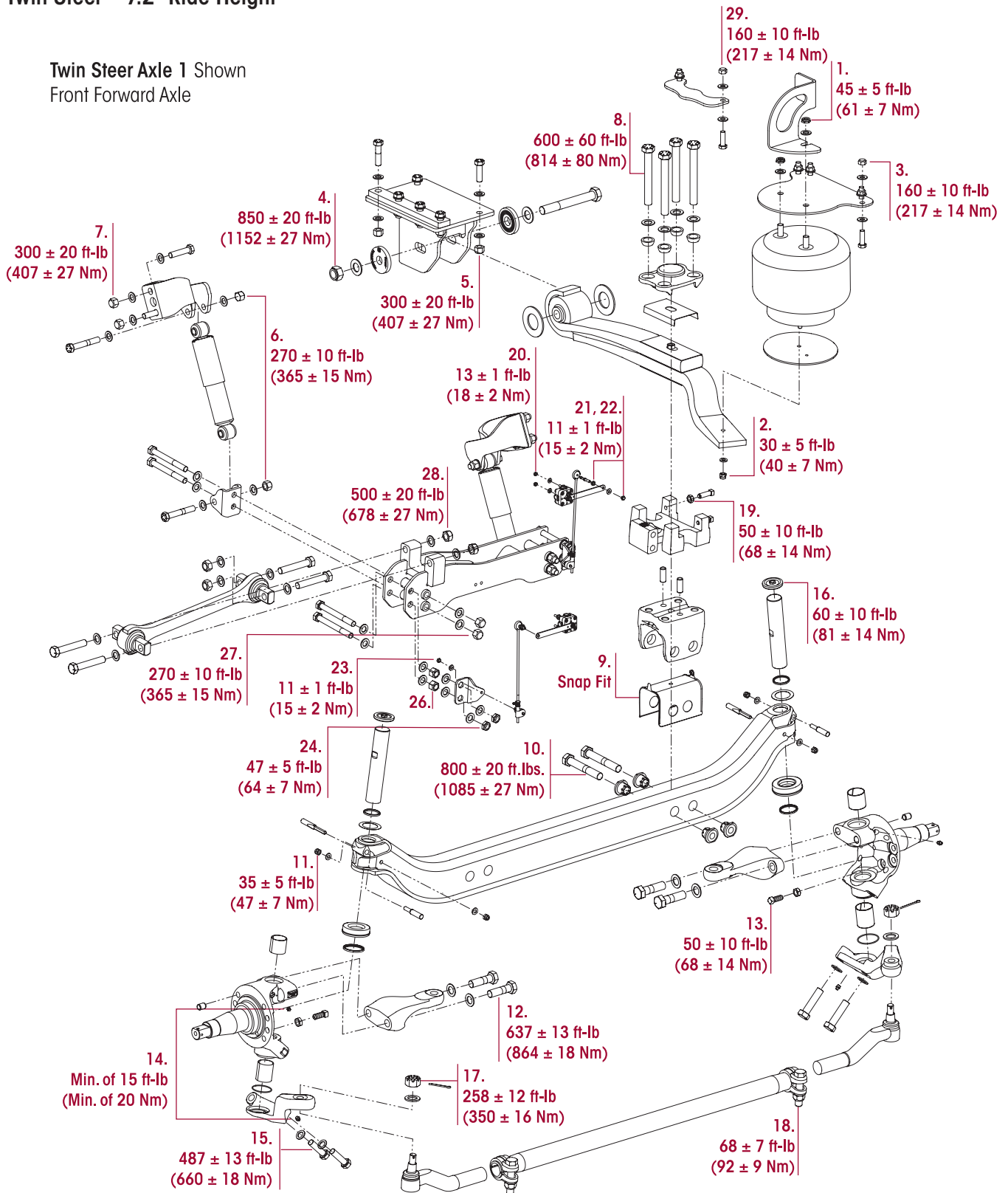



**AIRTEK NXT with STEERTEK NXT High-capacity Axle
Twin Steer**

HENDRICKSON RECOMMENDED TORQUE SPECIFICATIONS

NO.	COMPONENT	FASTENER		TORQUE VALUE	
		QTY.	SIZE	FOOT POUNDS	NEWTON METERS
WARNING: ENSURE THE CLAMP GROUP IS ALIGNED PROPERLY PRIOR TO TIGHTENING FASTENERS. FAILURE TO DO SO CAN CAUSE LOSS OF VEHICLE CONTROL, PROPERTY DAMAGE OR PERSONAL INJURY.					
1	Upper Air Spring Locknut	8	¾"-16 UNF	45 ± 5	61 ± 7
2	Lower Air Spring Locknut	4	½"-13 UNC	30 ± 5	40 ± 7
3	Air Spring Frame Mounting Locknut	16	⅝"-11 UNC	160 ± 10	217 ± 14
4	QUIK-ALIGN Locknut	4	1 ⅛"-12 UNF	850 ± 20	1152 ± 27
5	Frame Hanger Mounting Locknut	24	¾"-10 UNC	300 ± 20	407 ± 27
6	Upper and Lower Shock Absorber Locknut	8	¾"-10 UNC	270 ± 10	365 ± 15
7	Shock Bracket Frame Mounting Locknut	8	¾"-10 UNC	300 ± 20	407 ± 27
8	Clamp Group Hex Bolt	16	1"-8 UNC	600 ± 60	814 ± 80
9	Axle Seat Liner	4		Snap Fit	Snap Fit
10	Axle Seat Fasteners at the Bolt Head	8	1"-8 UNC	800 ± 20	1085 ± 27
11	Kingpin Draw Key Nut	8	7/16"-14 UNC	35 ± 5	47 ± 7
12	Knuckle Assembly to Steering Arm	8	1"-14 UNF	637 ± 13	864 ± 18
13	Knuckle /Axle Wheel Stop Bolt	4	⅝"-11 UNC	50 ± 10	68 ± 14
14	Grease Zerk	8		Minimum of 15	Minimum of 20
15	Knuckle Assembly to Tie Rod Arm	8	7/8"-14 UNF	487 ± 13	660 ± 18
16	Grease Cap	4		60 ± 10	81 ± 14
17	Tie Rod Ends to Tie Rod Arm	4	7/8" Castle Nut	258 ± 12	350 ± 16
18	Tie Rod Tube to Tie Rod Ends	4	¾"-10 UNC	68 ± 7	92 ± 9
19	Set Screw to Bottom Cap	8	⅝"-11 UNC	50 ± 10	68 ± 14
20	Height Control Valve (HCV)	4	¼"-20 UNC	13 ± 1	18 ± 2
21	Height Control Valve to HCV Linkage	4	5/16"-18 UNC	11 ± 1	15 ± 2
22	HCV Linkage Jam Nut	4	5/16"-18 UNC	11 ± 1	15 ± 2
23	Height Control Valve to HCV Bracket	4	5/16"-18 UNC	11 ± 1	15 ± 2
24	HCV Bracket	4	¾"-10 UNC	47 ± 5	64 ± 7
25	Linkage Rod Clamp	2		Until Securely Fastened	
26	Axle Bracket to HCV Bracket	16	¾"-10 UNC	270 ± 10	365 ± 15
27	Axle Bracket to Shock Absorber Bracket	16	¾"-10 UNC	270 ± 10	365 ± 15
28	Axle Bracket to TRAAX Rod	8	7/8"-14 UNF	500 ± 20	678 ± 27
29	Jounce Stop	8	⅝"-11 UNC	160 ± 10	217 ± 14

• All hardware ¼" and greater is Grade 8 with no additional lubrication.

Single Steer • 7.2" Ride Height

Hendrickson Recommended Torque Values Provided
in Foot Pounds and In Newton Meters

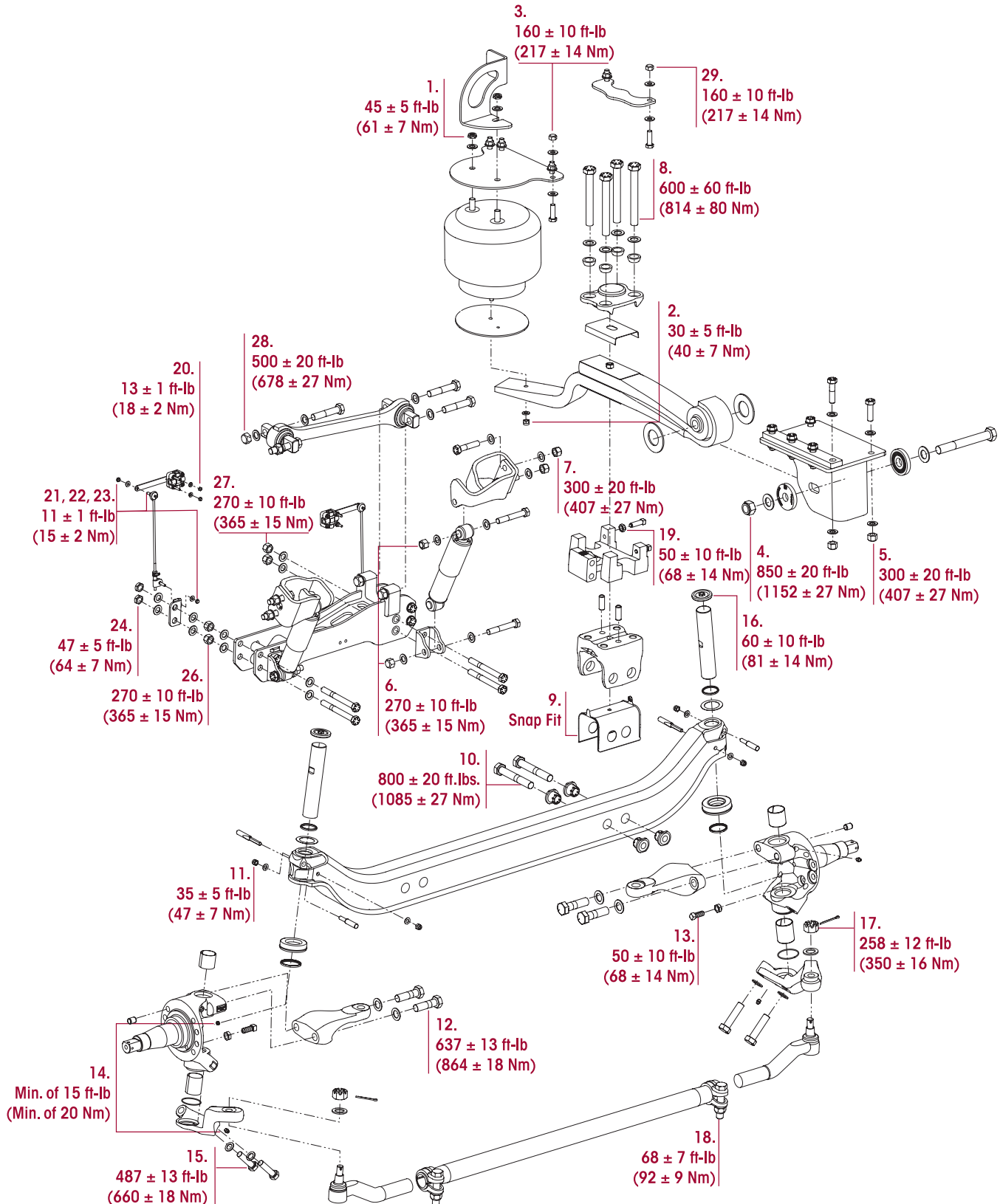



**AIRTEK NXT with STEERTEK NXT High-capacity Axle
Single Steer**

HENDRICKSON RECOMMENDED TORQUE SPECIFICATIONS

NO.	COMPONENT	FASTENER		TORQUE VALUE	
		QTY.	SIZE	FOOT POUNDS	NEWTON METERS
WARNING: ENSURE THE CLAMP GROUP IS ALIGNED PROPERLY PRIOR TO TIGHTENING FASTENERS. FAILURE TO DO SO CAN CAUSE LOSS OF VEHICLE CONTROL, PROPERTY DAMAGE OR PERSONAL INJURY.					
1	Upper Air Spring Locknut	8	¾"-16 UNF	45 ± 5	61 ± 7
2	Lower Air Spring Locknut	4	½"-13 UNC	30 ± 5	40 ± 7
3	Air Spring Frame Mounting Locknut	16	⅝"-11 UNC	160 ± 10	217 ± 14
4	QUIK-ALIGN Locknut	4	1 ⅛"-12 UNF	850 ± 20	1152 ± 27
5	Frame Hanger Mounting Locknut	24	¾"-10 UNC	300 ± 20	407 ± 27
6	Upper and Lower Shock Absorber Locknut	8	¾"-10 UNC	270 ± 10	365 ± 15
7	Shock Bracket Frame Mounting Locknut	8	¾"-10 UNC	300 ± 20	407 ± 27
8	Clamp Group Hex Bolt	16	1"-8 UNC	600 ± 60	814 ± 80
9	Axle Seat Liner	4		Snap Fit	Snap Fit
10	Axle Seat Fasteners at the Bolt Head	8	1"-8 UNC	800 ± 20	1085 ± 27
11	Kingpin Draw Key Nut	8	7/16"-14 UNC	35 ± 5	47 ± 7
12	Knuckle Assembly to Steering Arm	8	1"-14 UNF	637 ± 13	864 ± 18
13	Knuckle /Axle Wheel Stop Bolt	4	⅝"-11 UNC	50 ± 10	68 ± 14
14	Grease Zerk	8		Minimum of 15	Minimum of 20
15	Knuckle Assembly to Tie Rod Arm	8	7/8"-14 UNF	487 ± 13	660 ± 18
16	Grease Cap	4		60 ± 10	81 ± 14
17	Tie Rod Ends to Tie Rod Arm	4	7/8" Castle Nut	258 ± 12	350 ± 16
18	Tie Rod Tube to Tie Rod Ends	4	¾"-10 UNC	68 ± 7	92 ± 9
19	Set Screw to Bottom Cap	8	⅝"-11 UNC	50 ± 10	68 ± 14
20	Height Control Valve (HCV)	4	¼"-20 UNC	13 ± 1	18 ± 2
21	Height Control Valve to HCV Linkage	4	5/16"-18 UNC	11 ± 1	15 ± 2
22	HCV Linkage Jam Nut	4	5/16"-18 UNC	11 ± 1	15 ± 2
23	Height Control Valve to HCV Bracket	4	5/16"-18 UNC	11 ± 1	15 ± 2
24	HCV Bracket	4	¾"-10 UNC	47 ± 5	64 ± 7
25	Linkage Rod Clamp	2		Until Securely Fastened	
26	Axle Bracket to HCV Bracket	16	¾"-10 UNC	270 ± 10	365 ± 15
27	Axle Bracket to Shock Absorber Bracket	16	¾"-10 UNC	270 ± 10	365 ± 15
28	Axle Bracket to TRAAX Rod	8	7/8"-14 UNF	500 ± 20	678 ± 27
29	Jounce Stop	8	⅝"-11 UNC	160 ± 10	217 ± 14

• All hardware ¼" and greater is Grade 8 with no additional lubrication.



Hendrickson Recommended Torque Values Provided
in Foot Pounds and In Newton Meters

Wheel End Assembly with Air Disc Brakes

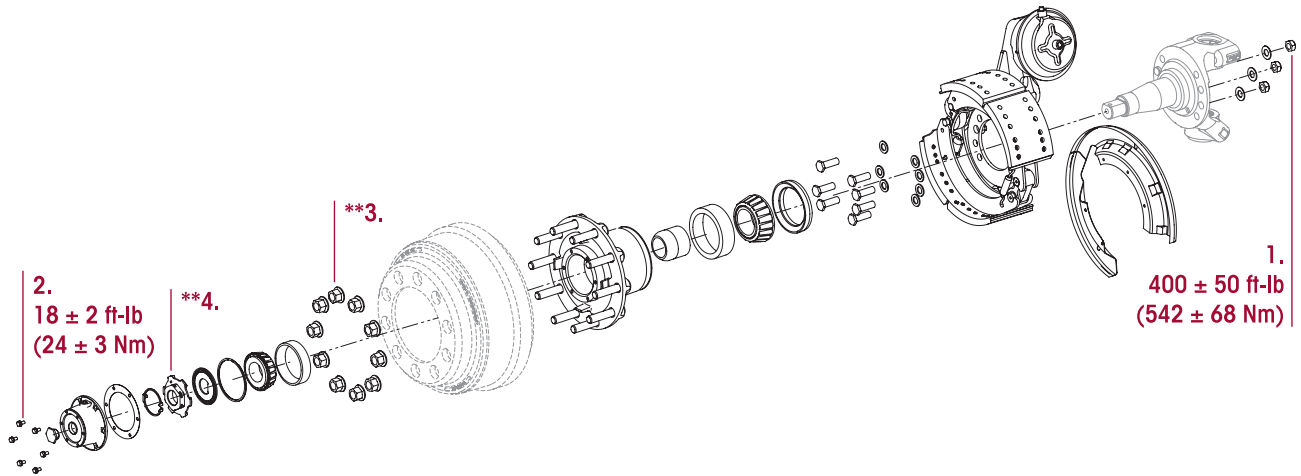

AIRTEK NXT with STEERTEK NXT High-capacity Axle

HENDRICKSON RECOMMENDED TORQUE SPECIFICATIONS

NO.	COMPONENT	FASTENER		*TORQUE VALUE	
		QTY.	SIZE	FOOT POUNDS	NEWTON METERS
1	Torque Plate Mounting Fasteners	24	M18	315 ± 10	428 ± 13
2	Hub Cap Fasteners	24	5/16"	18 ± 2	24 ± 3
3	Wheel Nut	20	M22	**	**
4	Outer Spindle Nut	2		**	**

NOTE: * Recommended torque values for fasteners originally supplied by Hendrickson, if non-Hendrickson fasteners are used, follow torque specifications listed in the vehicle manufacturer's service manual. Hendrickson is not responsible for maintaining vehicle manufacturer's torque values.

** For torque values and interval specifications, refer to the wheel end component manufacturers listed in the Parts List section of this publication.



SECTION 12 Alignment Specifications

AIRTEK NXT with STEERTEK NXT High-capacity Axle

FRONT SUSPENSION ALIGNMENT SPECIFICATIONS			
CAMBER ¹	DESIGN SPECIFICATION	RANGE	
		MINIMUM	MAXIMUM
LEFT	0.0°±1.0°	-1.0°	+1.0°
RIGHT	-0.25°±1.0°	-1.25°	+0.75°
CROSS	0.0°	—	+2.0°
CAMBER NOTES:			
<ol style="list-style-type: none"> The camber angle is not adjustable. DO NOT bend the axle or otherwise try to adjust camber. If found out of specification, notify Hendrickson Tech Services for further information. 			
CASTER ^{1,2}	DESIGN SPECIFICATION	RANGE	
		MINIMUM	MAXIMUM
LEFT	3°±1.0°	+2°	+4°
RIGHT	3°±1.0°	+2°	+4°
CROSS ³	0.0°	—	+1.5°
CASTER NOTES:			
<ol style="list-style-type: none"> Caster is measured with the vehicle at specified ride height for air suspension systems. It is critical that the vehicle front and rear ride height are within specification prior to performing a caster measurement or adjustment. See Hendrickson ride height specifications and procedure. In most cases actual vehicle caster is defined with the frame rails at zero slope. Refer to the vehicle manufacturer's specifications for correct frame rail slope. (Both the alignment surface and the vehicle's frame rails should be level during execution of alignment procedures). For vehicles with a positive frame rake (higher in rear) add the frame slope (in degrees) to the caster reading to determine true vehicle caster. The cross caster angle is not adjustable – DO NOT bend axle or otherwise try to adjust cross caster. If found out of specifications notify Hendrickson Tech Services for further information. Changes to caster can be attained by using caster shims as provided by the vehicle manufacturer or chassis and body manufacturer. Caster shims must match, side to side, to reduce uneven loading to the suspension components. The use of two different angle caster shims will not correct cross caster. Example of caster adjustment: 4.5° Right Hand / 5° Left Hand would require one, 1.0 shim on each side to increase caster and achieve 5.50° Right Hand / 6.00° Left Hand, which is in specification. DO NOT attempt to use uneven shims. 			
Hendrickson recommends the following practices:			
TOTAL TOE	DESIGN SPECIFICATION ¹	RANGE	
		MINIMUM	MAXIMUM
	1/16" ± 1/32" (0.06" ± 0.03")	1/32" (0.03")	3/32" (0.09")
TOE-IN NOTES:			
<ol style="list-style-type: none"> Toe-in is to be set and adjusted in the normal vehicle unladed configuration. Actual vehicle curb weight on the ground. Toe should be checked at the tires front and rear tread center, at a distance above ground equal to the tire's rolling radius. 			



SECTION 13

Troubleshooting Guide

AIRTEK NXT with STEERTEK NXT High-capacity Axle

TROUBLESHOOTING GUIDE		
CONDITION	POSSIBLE CAUSE	CORRECTION
Worn or damaged kingpins and kingpin bushings	Dirt in system– contaminated lubricant	Polish and inspect the kingpin, replace the bushing and seals, then follow specified lubrication procedures.
	Incorrect lubricant	Lubricate the axle with specified lubricant.
	Axle not lubricated at scheduled frequency	Lubricate the axle at scheduled frequency.
	Incorrect lubrication procedures	Use the correct lubrication procedures.
	Lubrication interval not compatible with operating conditions	Change the lubrication interval to match operating conditions.
	Worn or missing seals	Replace the worn or missing seals.
Vibration or shimmy of front axle during operation	Caster out of specification	Check the ride height prior and adjust caster to specification.
	Wheels and/or tires out of balance	Balance or replace the wheels and/or tires.
	Worn shock absorbers	Replace the shock absorbers.
	Worn thrust washers and rear hanger clamps	Replace the thrust washers and rear hanger clamps.
	Broken engine mount	Replace the engine mount.
Excessive wear on tires or uneven tire tread wear	Wheel bearing adjustment	Adjust the wheel bearing to the manufacturer's specifications.
	Tires have incorrect air pressure	Adjust the tire pressure to the vehicle manufacturer's specifications.
	Tires out of balance	Balance or replace the tires.
	Incorrect tandem axle alignment	Align the front tandem axles.
	Incorrect toe setting	Adjust the toe-in to Hendrickson's specifications.
	Incorrect steering arm geometry	Repair the steering system as necessary.
	Worn kingpin bushings	Replace the kingpin bushings.
	Excessive wheel bearing end play	Adjust the wheel nut torque to the vehicle manufacturer's specifications, replace worn or damaged wheel bearings.
Wheel bearing adjustment	Adjust wheel bearing to the manufacturer's specifications.	
Tie rod ends are worn and require replacement	Tie rod ends need lubrication	Lubricate tie rod end. Ensure lubrication schedule is followed.
	Severe operating conditions	Increase frequency of inspection and lubrication intervals.
	Damaged boot tie rod end on	Replace the tie rod end.
Worn or broken steering ball stud	Drag link fasteners tightened past specified torque	Tighten the drag link fasteners to the specified torque.
	Lack of lubrication or incorrect lubricant	Lubricate the linkage with specified lubricant.
	Power steering stops out of adjustment	Adjust steering stops to Hendrickson's specifications.



AIRTEK NXT with STEERTEK NXT High-capacity Axle

TROUBLESHOOTING GUIDE

CONDITION	POSSIBLE CAUSE	CORRECTION
Vehicle is hard to steer	Low pressure in the power steering system	Repair the power steering system.
	Steering linkage needs lubrication	Lubricate the steering linkage.
	Steering knuckles are binding	Check the vertical clearance.
	Incorrect steering arm geometry	Repair the steering system as necessary.
	Caster out of specification	Check the ride height prior and adjust caster to specification.
	Tie rod ends hard to move	Replace the tie rod ends.
	Worn thrust bearing	Replace the thrust bearing.
Bent or broken tie rod cross tube, tie rod end ball stud or tie rod end NOTE: Damaged components require replacement	Steering gear box internal problem	Perform the steering gear trouble shooting procedures per steering gear box manufacturer's guidelines.
	Pump/gear relief valve pressure setting exceeds system specifications	Adjust the power steering system to manufacturer's specified pressure.
	Steering gear poppets improperly set or malfunctioning	Check for proper operation or adjust poppets to vehicle manufacturer's specifications.
	Axle stops improperly set	Set axle stops to vehicle manufacturer's specifications
Suspension has harsh or bumpy ride	Severe duty cycle service	Increase frequency of inspection and lubrication intervals
	Air spring not inflated	Check the air supply to air spring, repair or replace as necessary.
	Air spring ride height out of specification	Adjust the ride height to proper specification.
	Broken or worn leaf spring	Replace the leaf spring assembly.
Restricted steering radius	Front suspension overloaded	Redistribute the steer axle load.
	Steering stops not adjusted correctly	Adjust the steering stops to achieve the correct wheel cut.
Vehicle leans	Ride height incorrect	Adjust the ride height to specification.
	Air spring(s) are not inflated	Repair the source of air pressure loss.
	Suspension is not torqued correctly at installation	See Preventive Maintenance section in this publication. Fasteners not supplied by Hendrickson, follow the torque specification listed in the vehicle manufacturer's service manual.
	Leaf spring broken	Replace the leaf spring assembly.
	Excessive weight bias	Contact the vehicle manufacturer or Hendrickson Tech Services.
Vehicle wanders	Caster out of specifications	Check the ride height prior and adjust caster to specification.
	Incorrect toe setting	Adjust the toe to specification.
	Air in the power steering system	Remove the air form the power steering systems.
	Rear ride height out of adjustment	Adjust the ride height to specification, see Alignment & Adjustment section in this publication.
	Front ride height out of adjustment	



SECTION 14

Reference Material

This technical publication covers Hendrickson Truck Suspension's recommended procedures for our parts/products. Other components play a major role in overall performance and Hendrickson recommends you follow the specific vehicle manufacturer's recommendation for care and maintenance. Some recommended procedures have been developed by TMC and Hendrickson supports these recommendations.

To obtain copies of TMC's Recommended Practices Manual at:

TMC / ATA Headquarters
950 North Glebe Road, Suite 210
Arlington, VA 22203-4181

Phone: 703-838-1763
website: tmc.trucking.org
online ordering: /Shopping

Actual product performance may vary depending upon vehicle configuration, operation, service and other factors. All applications must comply with applicable Hendrickson specifications and must be approved by the respective vehicle manufacturer with the vehicle in its original, as-built configuration. Contact Hendrickson for additional details regarding specifications, applications, capacities, and operation, service and maintenance instructions.

Call Hendrickson at 630.910.2800 or 855.RIDERED (855.743.3733) for additional information.



www.hendrickson-intl.com

17730-280 Rev A 02-26

© 2026 Hendrickson USA, L.L.C. All Rights Reserved. All trademarks shown are owned by Hendrickson USA, L.L.C., or one of the affiliates, in one or more countries. Information contained in this literature was accurate at the time of publication. Product changes may have been made after the copyright date that are not reflected.

TRUCK COMMERCIAL VEHICLE SYSTEMS
800 South Frontage Road
Woodridge, IL 60517-4904 USA
855.743.3733 (Toll-free U.S. and Canada)
630.910.2800 (Outside U.S. and Canada)
Fax 630.910.2899

Printed in United States of America