

# **CAM TUBE SYSTEM™**

## Hendrickson genuine replacement cam tubes

Hendrickson's revolutionary Cam Tube System™ is patented<sup>▲</sup> with a unique 4-tabbed design. Engineered to perform, this 4-tabbed Cam Tube System is manufactured with tight tolerances creating a clamping force that is symmetric around the cam tube.

<sup>▲</sup> This product is covered by at least one or more U.S. and/or foreign patents and/or pending U.S. and/or foreign patent applications. See Hendrickson for details.

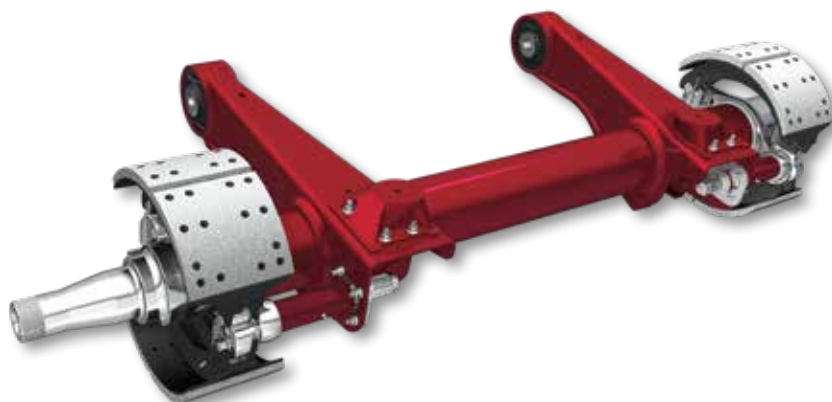
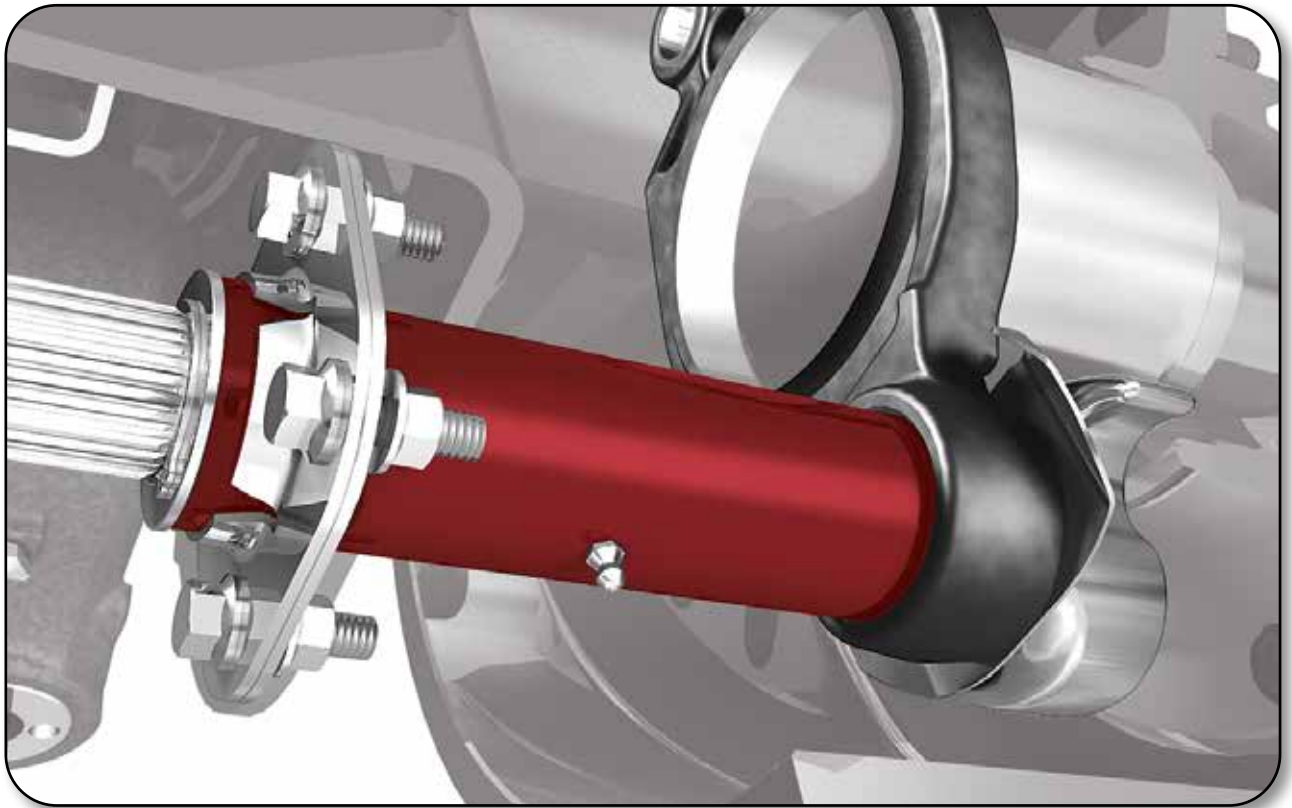

To learn more about Cam Tube System,  
call 866.743.3247 or visit  
[www.hendrickson-intl.com](http://www.hendrickson-intl.com)

 **HENDRICKSON**  
*The World Rides On Us®*

# CAM TUBE SYSTEM™



Hendrickson's 4-Tabbed Design

Competitor's 2-Tabbed Design

Competitor's O-Ring Design

## Structural Design

Hendrickson's 4-tabbed design is manufactured to perform.

- The symmetric clamping holds the cam tube in position to help prevent cam tube rotation, which can cause premature wear to the brake spiders and could result in an expensive replacement of the HALFTRAAX™ axle / beam weldment.

Bent washer design provides increased durability and resistance to rotation versus the flat design.

- Bent to allow the washer to be common between a 15" and 16.5" diameter INTRAAX® brake.

## Mechanical Properties

Hendrickson's cam tube clamping bracket is manufactured using high-strength, low alloy, high quality steel.

- On certain will-fit brands of cam tubes, testing indicates the clamping bracket mechanical properties have a lower torque causing less resistance to movement than Hendrickson's bracket.
- The clamping force will not deform the plate.

Hendrickson's cam tube bushing has internal lubricants to reduce friction and extend wear life.

- Many competitor bushings are glass-filled nylon and have NO internal lubricants.

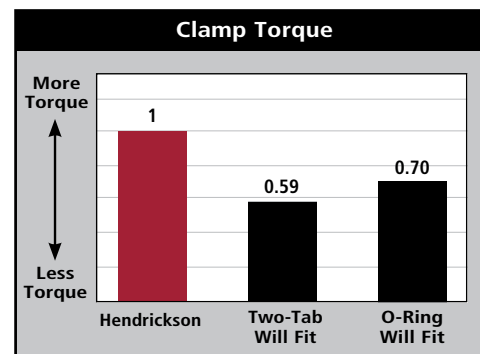

Above clamp torque data is based upon internal testing



**NOTE:** Look for the orange label with the black-filled slack adjuster image and L748 B 08-05 on the bottom edge of the label to ensure that it is a Hendrickson Genuine Part.

*Actual product performance may vary depending upon vehicle configuration, operation, service and other factors.*

*All applications must comply with applicable Hendrickson specifications and must be approved by the respective vehicle manufacturer with the vehicle in its original, as-built configuration. Contact Hendrickson for additional details regarding specifications, applications, capacities, and operation, service and maintenance instructions.*

Call Hendrickson at **330.489.0045** or **866.RIDEAIR (743.3247)** for additional information.



www.hendrickson-intl.com

**TRAILER COMMERCIAL VEHICLE SYSTEMS**  
2070 Industrial Place SE  
Canton, OH 44707-2641 USA  
866.RIDEAIR (743.3247)  
330.489.0045 • Fax 800.696.4416

**Hendrickson Canada ULC**  
2825 Argenta Road, Unit #2 - 4  
Mississauga, ON Canada L5N 8G6  
800.668.5360  
905.789.1030 • Fax 905.802.9423

**Hendrickson Mexicana**  
Circuito El Marqués Sur #29  
Parque Industrial El Marqués  
Pob. El Colorado, Municipio El Marqués,  
Querétaro, México C.P. 76246  
+52 (442) 296.3600 • Fax +52 (442) 296.3601

L1214 Rev B 01-22

© 2013 - 2022 Hendrickson USA, L.L.C. All Rights Reserved. All trademarks shown are owned by Hendrickson USA, L.L.C., or one of its affiliates, in one or more countries. Information contained in this literature was accurate at the time of publication. Product changes may have been made after the copyright date that are not reflected.

Printed in United States of America