





## SECTION 1

# Introduction

This publication is intended to acquaint and assist maintenance personnel in the preventive maintenance, service, repair and rebuild of the Hendrickson ULTIMAAX® rear rubber suspension system for applicable Kenworth and Peterbilt Vehicles.

### NOTE

Use only Hendrickson Genuine parts for servicing this suspension system.

It is important to read and understand this entire Technical Procedure publication and all work instructions and safety related information provided by the vehicle manufacturer prior to performing any maintenance, service, repair, or rebuild of this product. The information in this publication contains parts lists, safety information, product specifications, features, proper maintenance, service, repair, and rebuild instructions for ULTIMAAX suspensions.

Hendrickson reserves the right to make changes and improvements to its products and publications at any time. Contact Hendrickson Tech Services for information on the latest version of this manual at 855-743-3733 (toll-free U.S. and Canada), 630-910-2800 (outside U.S. and Canada) or e-mail: [wtechservices@hendrickson-intl.com](mailto:wtechservices@hendrickson-intl.com).

**The latest revision of this publication is available online at [www.hendrickson-intl.com](http://www.hendrickson-intl.com).**

## SECTION 2

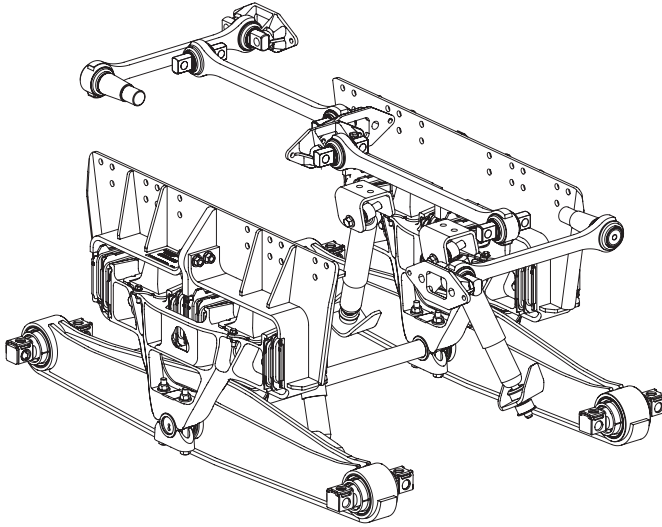
# Product Description

**ULTIMAAX** is an advanced severe-duty rear rubber suspension designed to balance outstanding durability, empty ride quality, loaded stability and mobility. Through its unique design, the system offers premium ride quality in both empty and loaded conditions, with increasing stability as the load increases. The ULTIMAAX system is capable of extremely high articulation for demanding job-site or off-highway conditions. When loaded, it delivers up to 17.5 inch of diagonal wheel articulation.

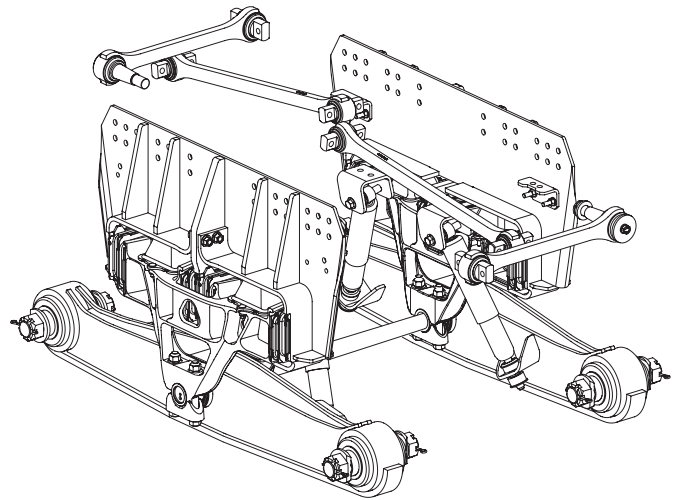
- **Equalizing beam** — Formed and robotically welded to provide a narrow profile for weight savings. Distributes load equally between axles to improve maneuverability, stability and handling. Increases ground clearance with flat bottom design. Lowers the center of gravity to increase stability.
- **Frame hangers** — Optimized design to balance durability and weight savings. Fabricated to offer flexibility with multiple truck configurations.
- **Premium rubber bushings** — Require no lubrication. Help extend service life and reduce re-bush time with rugged bar pin axle connection. Improve articulation with high performance design.
- **Progressive load springs** — Stiffness of progressive load springs increase as load increases, providing a unique balance of empty ride quality and loaded stability.
- **Rubber shear springs** — Primary springs in unloaded condition, providing superb ride quality. React to longitudinal loads during braking and accelerating for minimal displacement.
- **Saddle** — Triangular geometry provides structure and durability. Weight efficient design helps to increase payload, while offering a considerable weight savings versus competitive suspensions.
- **Torque rods** — **Longitudinal torque rods** are engineered to optimize resistance to axle wind-up during acceleration and braking. **Transverse torque rods** ensure maximum lateral axle control and straight line suspension stability. **V-rods** are engineered to evenly distribute higher capacity longitudinal and lateral loads into the chassis connections.



FIGURE 2-1



**46K • 52K Pound Capacity**



**60K • 70K Pound Capacity**

## ULTIMAAX® SPECIFICATIONS

Suspension Rating (lb)	46,000	52,000	60,000.	70,000.
Suspension Installed Weight <sup>1</sup> (lb)	1,179	1,198	1,507	1,750
GVW Approval <sup>2</sup>	Contact Vehicle Manufacturer		Contact Vehicle Manufacturer	
GCW Approval <sup>2</sup> (lb)	400,000		450,000	
Site Travel Rating <sup>3</sup> (lb)	70,000	75,000	85,000	95,000
Diagonal Articulation <sup>4</sup> (in)	17.5		17.5	
Lift Axles	Approved		Approved	
Ride Heights <sup>5</sup> (in)	9.5 – 13		10.15 – 13	
Axle Spacing <sup>6</sup> (in)	52, 54, 56, 60		54, 56, 60	

Hendrickson approves the use of ULTIMAAX in the following vocational truck applications: dump, concrete mixer, refuse, logging, crane / boom, platform and fire / rescue. All such applications must comply with applicable Hendrickson specifications and must also be approved by the respective vehicle manufacturer with the vehicle in its original, as-built configuration. Contact Hendrickson and the respective vehicle manufacturer for approval of additional applications.

1. Installed weight includes full suspensions with torque rods and without shock absorbers. Add 51 pound for shock absorbers at 46,000 to 52,000 pound capacities and 56 pound for 60,000 to 70,000 pound capacities.
2. Suspension must be paired with appropriate axle rating.
3. Site travel rating – operators using vehicles equipped with liftable pusher or tag axles must not exceed published ratings. Job-site travel ratings are limited to no more than five percent of vehicle operation at speed not to exceed five mph. Liftable pusher or tag axles should only be raised (or unloaded) to improve vehicle maneuverability in job-site applications or when vehicle is empty. Job-site travel ratings are consistent with published axle manufacturer's limitations. Axle and suspension job-site travel ratings must not be exceeded.
4. Suspension articulation may exceed vehicle's capability and may be limited by vehicle manufacturer; vehicle manufacturer installed axle stops may restrict suspension's articulation.
5. ULTIMAAX ride height measurements are taken from the centerline of the axle to the bottom of the truck frame.
6. Contact Hendrickson for availability of additional beam lengths.

Actual product performance may vary depending upon vehicle configuration, operation, service and other factors.



SECTION 3

# Important Safety Notice

Proper maintenance, service and repair are important to the reliable operation of the suspension. The procedures recommended by Hendrickson and described in this technical publication are methods of performing such maintenance, service and repair.

This technical publication should be read carefully to help prevent personal injury and to assure that proper methods are used. Improper maintenance, service or repair may damage the vehicle, cause personal injury, render the vehicle unsafe in operation, or void the manufacturer's warranty.

Failure to follow the safety precautions in this manual can result in personal injury and/or property damage. Carefully read and understand all safety related information within this publication, on all decals and in all such materials provided by the vehicle manufacturer before conducting any maintenance, service or repair.

## ■ EXPLANATION OF SIGNAL WORDS

Hazard "Signal Words" (Danger • Warning • Caution) appear in various locations throughout this publication. Information accented by one of these signal words must be observed to help minimize the risk of personal injury to service personnel, or possibility of improper service methods which may damage the vehicle or render it unsafe.



This is the safety alert symbol. It is used to alert you to potential personal injury hazards. Obey all safety messages that follow this symbol to avoid possible injury or death.

Additional Notes or Service Hints are utilized to emphasize areas of procedural importance and provide suggestions for ease of repair. The following definitions indicate the use of these signal words as they appear throughout the publication.



INDICATES AN IMMINENTLY HAZARDOUS SITUATION, WHICH IF NOT AVOIDED, WILL RESULT IN SERIOUS INJURY OR DEATH.



INDICATES A POTENTIAL HAZARDOUS SITUATION WHICH, IF NOT AVOIDED, CAN RESULT IN SERIOUS INJURY OR DEATH.



INDICATES A POTENTIAL HAZARDOUS SITUATION WHICH, IF NOT AVOIDED, MAY RESULT IN MINOR OR MODERATE INJURY.

**NOTE**

An operating procedure, practice condition, etc. which is essential to emphasize.

**SERVICE HINT**

A helpful suggestion that will make the service being performed a little easier and/or faster.

Also note that particular service operations may require the use of special tools designed for specific purposes. These special tools can be found in the "Special Tools" section of this publication.



The torque symbol alerts you to tighten the fasteners to a specific torque value. See Torque Specifications section of this publication.



## ■ SAFETY PRECAUTIONS

### WARNING

#### **FASTENERS**

DISCARD USED FASTENERS. ALWAYS USE NEW FASTENERS TO COMPLETE A REPAIR. FAILURE TO DO SO COULD RESULT IN FAILURE OF THE PART, OR MATING COMPONENTS, ADVERSE VEHICLE HANDLING, POSSIBLE PERSONAL INJURY, OR PROPERTY DAMAGE.

LOOSE OR OVER TORQUED FASTENERS CAN CAUSE COMPONENT DAMAGE, ADVERSE VEHICLE HANDLING, PROPERTY DAMAGE, OR POSSIBLE PERSONAL INJURY. MAINTAIN CORRECT TORQUE VALUE AT ALL TIMES. CHECK TORQUE VALUES ON A REGULAR BASIS AS SPECIFIED, USING A REGULARLY CALIBRATED TORQUE WRENCH. TORQUE VALUES SPECIFIED IN THIS TECHNICAL PUBLICATION ARE FOR HENDRICKSON SUPPLIED FASTENERS ONLY. IF NON-HENDRICKSON FASTENERS ARE USED, FOLLOW TORQUE SPECIFICATION LISTED IN THE VEHICLE MANUFACTURER'S SERVICE MANUAL.

### WARNING

#### **LOAD CAPACITY**

ADHERE TO THE PUBLISHED CAPACITY RATINGS FOR THE SUSPENSION. ADD-ON AXLE ATTACHMENTS AND OTHER LOAD TRANSFERRING DEVICES, SUCH AS LIFTABLE AXLES, CAN INCREASE THE SUSPENSION LOAD ABOVE ITS RATED AND APPROVED CAPACITIES, WHICH CAN RESULT IN COMPONENT DAMAGE AND ADVERSE VEHICLE HANDLING, POSSIBLE PERSONAL INJURY, OR PROPERTY DAMAGE.

### WARNING

#### **SUPPORT THE VEHICLE PRIOR TO SERVICING**

PLACE THE VEHICLE ON A LEVEL FLOOR AND CHOCK THE WHEELS TO PREVENT THE VEHICLE FROM MOVING OR ROLLING. DO NOT WORK AROUND OR UNDER A RAISED VEHICLE SUPPORTED BY ONLY A FLOOR JACK. ALWAYS SUPPORT A RAISED VEHICLE WITH RIGID SAFETY STANDS. FAILURE TO DO SO CAN CAUSE SERIOUS PERSONAL INJURY OR DAMAGE TO EQUIPMENT.

### WARNING

WHEN LIFTING THE VEHICLE TO PERFORM ANY VEHICLE SERVICE, ENSURE THE REAR AIR SUSPENSION DOES NOT FREELY HANG IN AN UNSUPPORTED CONDITION. USE SAFETY STANDS OR BLOCKS AS NEEDED TO FULLY SUPPORT THE SUSPENSION. FAILURE TO DO SO CAN CAUSE COMPONENT DAMAGE, MISALIGNMENT, PERSONAL INJURY, OR PROPERTY DAMAGE.

### CAUTION

#### **PROCEDURES AND TOOLS**

A TECHNICIAN USING A SERVICE PROCEDURE OR TOOL WHICH HAS NOT BEEN RECOMMENDED BY HENDRICKSON MUST FIRST SATISFY THEMSELVES THAT NEITHER THEIR SAFETY NOR THE VEHICLE'S SAFETY WILL BE JEOPARDIZED BY THE METHOD OR TOOL SELECTED. INDIVIDUALS DEVIATING IN ANY MANNER FROM THE INSTRUCTIONS PROVIDED ASSUME ALL RISKS OF POTENTIAL PERSONAL INJURY OR DAMAGE TO EQUIPMENT INVOLVED.

### WARNING

#### **PERSONNEL PROTECTIVE EQUIPMENT**

ALWAYS WEAR PROPER EYE PROTECTION AND OTHER REQUIRED PERSONAL PROTECTIVE EQUIPMENT TO HELP PREVENT PERSONAL INJURY WHEN PERFORMING VEHICLE MAINTENANCE, REPAIR, OR SERVICE.

### WARNING

#### **MODIFYING COMPONENTS**

DO NOT MODIFY OR REWORK PARTS WITHOUT AUTHORIZATION FROM HENDRICKSON. DO NOT SUBSTITUTE REPLACEMENT COMPONENTS NOT AUTHORIZED BY HENDRICKSON. USE OF MODIFIED, REWORKED, SUBSTITUTE, OR REPLACEMENT PARTS NOT AUTHORIZED BY HENDRICKSON MAY NOT MEET HENDRICKSON'S SPECIFICATIONS, AND CAN RESULT IN FAILURE OF THE PART, ADVERSE VEHICLE HANDLING, POSSIBLE PERSONAL INJURY, OR PROPERTY DAMAGE, AND WILL VOID ANY APPLICABLE WARRANTIES. USE ONLY HENDRICKSON AUTHORIZED REPLACEMENT PARTS.

### WARNING

#### **TORQUE RODS**

THIS HENDRICKSON SUSPENSION REQUIRES TORQUE RODS FOR SUSPENSION PERFORMANCE AND VEHICLE STABILITY. IF THESE TORQUE RODS ARE DISCONNECTED OR ARE NON-FUNCTIONAL, DO NOT OPERATE THE VEHICLE. OPERATING A VEHICLE WITH DISCONNECTED OR NON-FUNCTIONAL TORQUE RODS CAN RESULT IN ADVERSE VEHICLE HANDLING, COMPONENT DAMAGE, SUSPENSION/VEHICLE DAMAGE, AND/OR SEVERE PERSONAL INJURY.



**WARNING**

**SHOCK ABSORBERS**

THE SHOCK ABSORBERS ARE THE REBOUND TRAVEL STOPS FOR THE SUSPENSION. ANYTIME THE AXLE INSTALLED ON THE SUSPENSION IS SUSPENDED IT IS MANDATORY THAT THE SHOCK ABSORBERS REMAIN CONNECTED. REPLACEMENT OF SHOCK ABSORBERS WITH NON-HENDRICKSON PARTS CAN ALTER THE REBOUND TRAVEL OF THE SUSPENSION.

**WARNING**

**TORCH / WELDING**

DO NOT USE A CUTTING TORCH TO REMOVE ANY FASTENERS. THE USE OF HEAT ON SUSPENSION COMPONENTS WILL ADVERSELY AFFECT THE STRENGTH OF THESE PARTS. A COMPONENT DAMAGED IN THIS MANNER CAN RESULT IN ADVERSE VEHICLE HANDLING, POSSIBLE PERSONAL INJURY, OR PROPERTY DAMAGE.

EXERCISE EXTREME CARE WHEN HANDLING OR PERFORMING MAINTENANCE IN THE AREA OF THE EQUALIZING BEAM. DO NOT CONNECT ARC WELDING GROUND LINE TO THE EQUALIZING BEAM. DO NOT STRIKE AN ARC WITH THE ELECTRODE ON THE EQUALIZING BEAM. DO NOT USE HEAT NEAR THE EQUALIZING BEAM ASSEMBLY. DO NOT NICK OR GOUGE THE EQUALIZING BEAM. SUCH IMPROPER ACTIONS CAN DAMAGE THE EQUALIZING BEAM ASSEMBLY AND CAUSE ADVERSE VEHICLE HANDLING, POSSIBLE PERSONAL INJURY, OR PROPERTY DAMAGE.

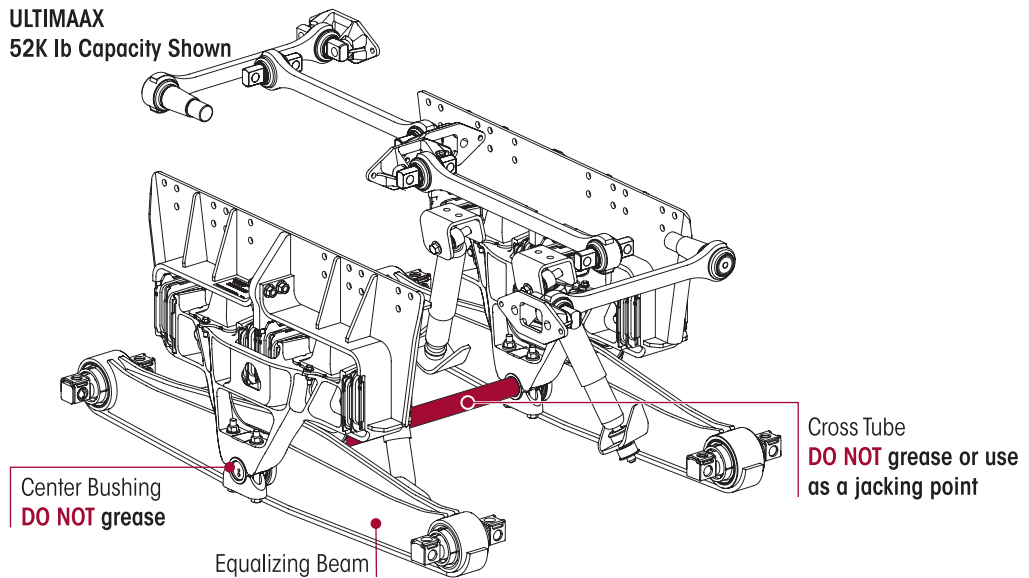
**WARNING**

**IMPROPER JACKING METHOD**

IMPROPER JACKING METHODS CAN CAUSE STRUCTURAL DAMAGE WHICH CAN CAUSE ADVERSE VEHICLE HANDLING, PROPERTY DAMAGE OR SEVERE PERSONAL INJURY AND WILL VOID HENDRICKSON'S WARRANTY.

- DO NOT USE THE SUSPENSION CROSS TUBE AS A JACKING POINT, SEE FIGURE 3-1, REFER TO VEHICLE MANUFACTURER FOR PROPER JACKING INSTRUCTIONS.
- ACCEPTABLE LIFTING POINTS FOR A VEHICLE AT THE RATED LOAD INCLUDE BUT ARE NOT LIMITED TO: THE AXLE, EQUALIZING BEAM, AND THE VEHICLE FRAME RAIL. REFER TO THE VEHICLE MANUFACTURER FOR PROPER JACKING INSTRUCTIONS.

**FIGURE 3-1**  
ULTIMAAX  
52K lb Capacity Shown



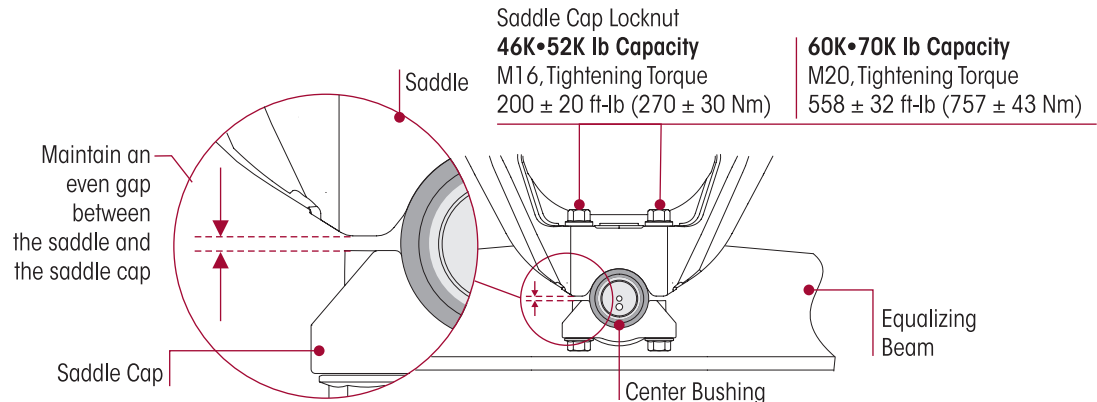


## CAUTION

### SADDLE CONNECTION

A SADDLE ASSEMBLY IS ATTACHED TO THE CENTER BUSHING OF EACH EQUALIZING BEAM WITH TWO (2) SADDLE CAPS. EACH SADDLE CAP USES TWO (2) BOLTS TO CLAMP THE CENTER BUSHING INNER METAL TO THE SADDLE. EACH SADDLE CAP MUST BE INSTALLED SO THAT THERE IS AN EVEN GAP BETWEEN THE SADDLE CAP AND THE BASE OF THE SADDLE LEGS AS SHOWN IN FIGURE 3-2. IF EACH SADDLE CAP IS NOT INSTALLED EVENLY, THE SADDLE LEGS COULD BECOME DEFORMED, RESULTING IN BENT BOLTS OR DAMAGED SADDLES.

FIGURE 3-2



## WARNING

### PARTS CLEANING

SOLVENT CLEANERS CAN BE FLAMMABLE, POISONOUS AND CAUSE BURNS. TO HELP AVOID SERIOUS PERSONAL INJURY, CAREFULLY FOLLOW THE MANUFACTURER'S PRODUCT INSTRUCTIONS AND GUIDELINES AND THE FOLLOWING PROCEDURE:

1. WEAR PROPER EYE PROTECTION
2. WEAR CLOTHING THAT PROTECTS YOUR SKIN
3. WORK IN A WELL VENTILATED AREA
4. DO NOT USE GASOLINE, OR SOLVENTS THAT CONTAIN GASOLINE. GASOLINE CAN EXPLODE
5. ACIDIC SOLUTIONS CANNOT BE USED ON ALUMINUM COMPONENTS.
6. HOT SOLUTION TANKS OR ALKALINE SOLUTIONS MUST BE USED CORRECTLY. FOLLOW THE MANUFACTURER'S RECOMMENDED INSTRUCTIONS AND GUIDELINES CAREFULLY TO HELP PREVENT PERSONAL ACCIDENT OR INJURY

DO NOT USE HOT SOLUTION TANKS OR WATER AND ALKALINE SOLUTIONS TO CLEAN GROUND OR POLISHED PARTS. DOING SO WILL CAUSE DAMAGE TO THE PARTS AND VOID ANY APPLICABLE WARRANTY.



## SECTION 4 Parts List

Refer to [Hendrickson Literature Number SP-301 \(ULTIMAAX for Kenworth\)](#), and [Hendrickson Literature Number SP-308 \(ULTIMAAX for Peterbilt\)](#) ULTIMAAX Advanced severe-duty rear rubber suspension system, available online at [www.hendrickson-intl.com](http://www.hendrickson-intl.com)

FIGURE 4-1

**ULTIMAAX®**  
Advanced severe-duty rear rubber suspension system

In addition to its excellent durability, ULTIMAAX® delivers enhanced stability, handling and ride quality even in the most severe-duty environments where vehicles encounter harsh and unexpected ground conditions. The integration of Hendrickson's proven walking (equalizing) beam technology, with its patented progressive rate spring, provides a balance of loaded stability and unloaded ride quality even in the most rugged environments.

**SALES ACADEMY**  
HENDRICKSON

Document Title	Code	Release Date	File Size
45745-320 Product Profile Truck Rotating Bar Pin End Bushings	F	2/23/2023	1.07 MB
45745-147 Equalizing Beam and Components Selection Guide	G	5/14/2024	1.21 MB
45745-148 Torque Rod Selection Guide	G	10/27/2025	2.14 MB
SP-298 ULTIMAAX Parts List for Western Star Vehicles	C	7/29/2024	1.18 MB
SP-299 ULTIMAAX 54K - 58K - 63K Rear Suspension Parts List for Fire/Rescue	C	5/15/2018	0.94 MB
SP-301 ULTIMAAX Parts List for Kenworth Vehicles	D	1/31/2025	1.48 MB
SP-317 ULTIMAAX Rear Suspension for International Truck Vehicles	B	5/2/2025	1.3 MB
SP-308 ULTIMAAX Parts List for Peterbilt Vehicles	A	1/31/2025	0.9 MB
SP-301FR Listes de Pièces ULTIMAAX pour les Véhicules Kenworth	D	4/9/2025	1.49 MB
SP-308FR Listes de Pièces ULTIMAAX pour les Véhicules Peterbilt	A	4/17/2025	0.89 MB

### Parts Lists

Document Title	Code	Release Date	File Size
45745-320 Product Profile Truck Rotating Bar Pin End Bushings	F	2/23/2023	1.07 MB
45745-147 Equalizing Beam and Components Selection Guide	G	5/14/2024	1.21 MB
45745-148 Torque Rod Selection Guide	G	10/27/2025	2.14 MB
SP-298 ULTIMAAX Parts List for Western Star Vehicles	C	7/29/2024	1.18 MB
SP-299 ULTIMAAX 54K - 58K - 63K Rear Suspension Parts List for Fire/Rescue	C	5/15/2018	0.94 MB
SP-301 ULTIMAAX Parts List for Kenworth Vehicles	D	1/31/2025	1.48 MB
SP-317 ULTIMAAX Rear Suspension for International Truck Vehicles	B	5/2/2025	1.3 MB
SP-308 ULTIMAAX Parts List for Peterbilt Vehicles	A	1/31/2025	0.9 MB
SP-301FR Listes de Pièces ULTIMAAX pour les Véhicules Kenworth	D	4/9/2025	1.49 MB
SP-308FR Listes de Pièces ULTIMAAX pour les Véhicules Peterbilt	A	4/17/2025	0.89 MB

### Tech Bulletins

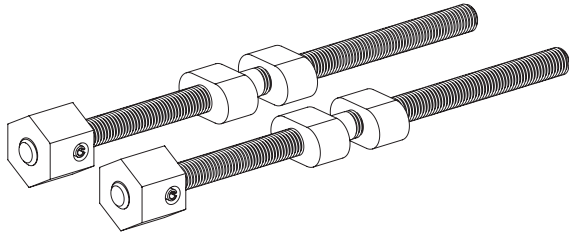
Document Title	Code	Release Date	File Size
12463-046 Don't Get Bent Out of Shape – Inspect Those Bushings!	A	3/13/2026	1.82 MB



## SECTION 5 Special Tools

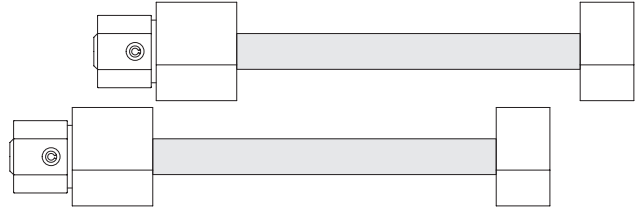
### SADDLE DISASSEMBLY TOOL

Hendrickson Part No. 66086-113L



### SADDLE ASSEMBLY TOOL

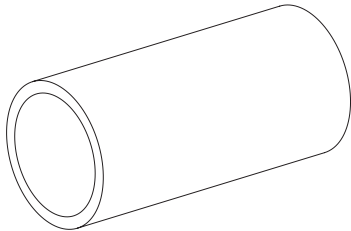
Hendrickson Part No. 66086-108L



### CENTER BUSHING TOOLS

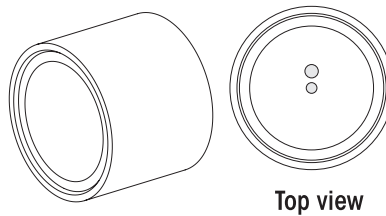
#### RECEIVING TOOL

Hendrickson Part No. 66086-112



#### INSTALLATION TOOL

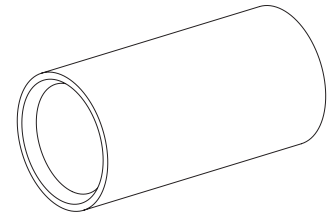
Hendrickson Part No. 66086-107



Top view

#### REMOVAL TOOL

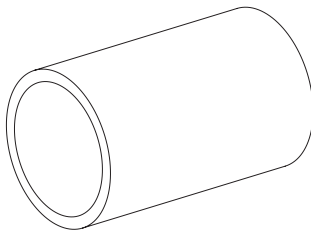
Hendrickson Part No. 66086-110



### BAR PIN STYLE END BUSHING TOOLS – 46,000 • 52,000 Pound Capacity

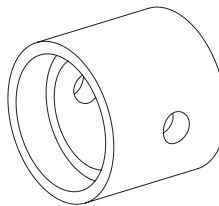
#### RECEIVING TOOL

Hendrickson Part No. 66086-111



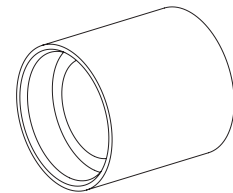
#### INSTALLATION TOOL

Hendrickson Part No. 66086-106



#### REMOVAL TOOL

Hendrickson Part No. 66086-109



### ADAPTER STYLE END BUSHING TOOLS – 60,000 • 70,000 Pound Capacity

OTC Part No. 1763

Visit [otctools.com](http://otctools.com)

No longer available, contact Hendrickson Truck Parts for available options.





## SECTION 6 Preventive Maintenance

Following appropriate inspection procedures are important to help ensure the proper maintenance and operation of the ULTIMAAX rear suspension and components function to their highest efficiency. Off-highway and severe service operating conditions may require more frequent inspections than on-highway service operation.

<b>HENDRICKSON RECOMMENDED INSPECTION INTERVALS</b>	<b>PRE-DELIVERY/ VISUAL INSPECTION</b>	<b>FIRST IN-SERVICE</b>	<b>PREVENTIVE MAINTENANCE</b>		
	<b>Within the first 100 miles (160 km)</b>	<b>1,500 Miles (2,500 km), 100 hours or whichever comes first</b>	<b>12,000 Miles (20,000 km), every 3 months 600 hours or whichever comes first</b>	<b>25,000 Miles (40,200 km), every 6 months 1200 hours or whichever comes first</b>	<b>50,000 Miles (80,400 km), every 12 months 2400 hours or whichever comes first</b>


Hendrickson recommends to visually inspect for proper assembly, function, overall condition, and any signs of damage. During the inspection intervals as shown, check for any unusual movement, loose or missing components, abrasive or adverse contact with other parts, damaged or cracked parts, and improper suspension function or alignment. Replace components as necessary.

Alignment of Axles	■	■			■
Cross Tube	■	■			■
Equalizing Beam Assembly	■	■		■	
• Beam End Axle Bracket	■	■			■
• Beam End Connection	■	■			■
• Center Bushing	■	■			■
Fasteners	■	■		■	■
Frame Hangers and Saddle Assembly	■	■		■	
Progressive Load Spring (PLS)	■	■	■		
Saddle Cap Connection	■	■			■
Shear Spring	■	■			■
Shock Absorber	■	■		■	
Torque Rods (Longitudinal, Transverse and V-rods)	■	■		■	
Wear and Damage				■	

See the vehicle manufacturer’s applicable publications for other preventive maintenance requirements.



## COMPONENT INSPECTION

- **Alignment** — Verify the alignment of axles are within the vehicle manufacturer's tolerances.
- **Cross tube** — Visually inspect for any cracks or dents. Refer to Cross Tube in this section.
- **Equalizing beam assembly** — Visually inspect beam end axle bracket, beam end connection and center bushing for any cracks or loose mounting hardware. Refer to Equalizing Beam Assembly in this section.
- **Fasteners** — Visually inspect for any loose or damaged fasteners on the entire suspension. Make sure all fasteners are tightened to the specified torque. Refer to the  Torque Specifications section of this publication. Use a calibrated torque wrench to check torque in a tightening direction. As soon as the fastener starts to move, record the torque. Correct the torque if necessary. Replace any worn or damaged fasteners.

### NOTE

Hendrickson recommends the use of Grade 8 bolts, hardened washers, and Grade C locknuts. Hardened washers are not necessary when flange head fasteners are used.

### NOTE

Torque values shown in this publication apply only if Hendrickson supplied fasteners are used. If non-Hendrickson fasteners are used, follow the torque specification listed in the vehicle manufacturer's service manual.

- **Frame hanger and saddle assembly** — Visually inspect for any cracks or loose mounting hardware. Replace if necessary, see the Component Replacement section of this publication for replacement procedure.
- **Progressive load spring (PLS)** — Visually inspect for any cracks, cuts, splits or bent progressive load spring. Refer to Progressive Load Springs in this section.
- **Saddle cap connection** — Visually inspect for any signs of movement or looseness. Ensure the fasteners are tightened to the specified torque. Refer to Saddle Cap Connection in this section.
- **Shear spring** — Visually inspect for any signs of bent or burred edges or bonding separation of the rubber. Refer to Shear Springs in this section.
- **Shock absorber** — Visually inspect for any signs of dents or leakage, misting is not considered a leak. See Shock Absorbers in this section.
- **Torque rod • V-rod** — All torque rods • V-rods must be inspected for looseness, torn or shredded rubber, and proper fastener torque. If there is metal-to-metal contact in the bushing joint, this is a sign of excessive bushing wear and the torque rod needs to be serviced. Refer to Torque Rod in this section.
- **Wear and damage** — Inspect all parts of the suspension for wear and damage. Look for bent or cracked parts.

## CROSS TUBE

The ULTIMAAX cross tube connects the two (2) equalizing beams through the equalizing beam's center bushings, see Figure 6-1. The cross tube has clearance to float side-to-side in the center bushings. The length of the cross tube will allow side-to-side movement of approximately 2½" (60 mm). For this reason, the cross tube **may appear polished** or missing paint at each end where it enters into the center bushings. This is normal. Also, the cross tube will rattle in straight position which is acceptable.



### WARNING

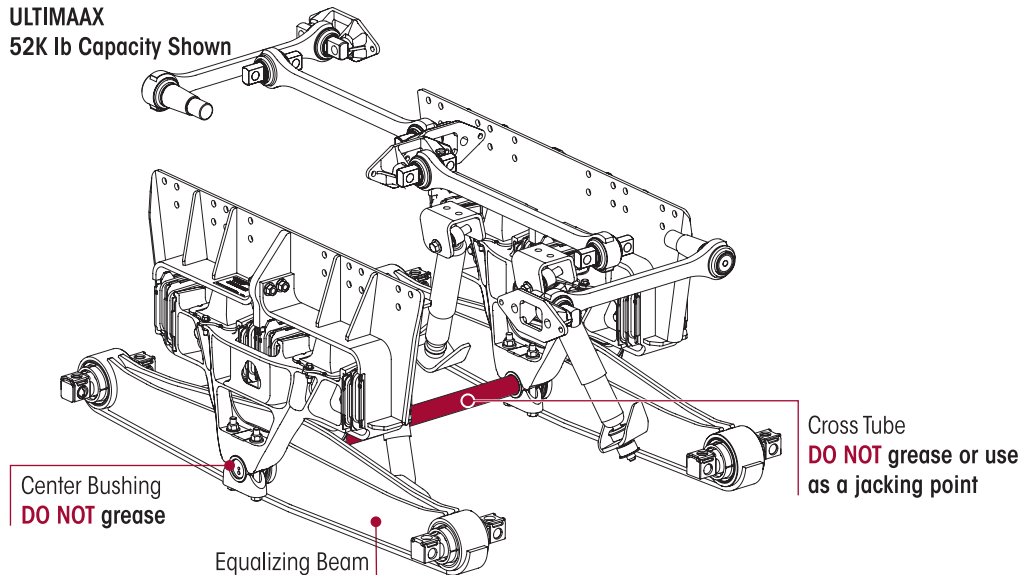
IMPROPER JACKING METHODS CAN CAUSE STRUCTURAL DAMAGE WHICH CAN CAUSE ADVERSE VEHICLE HANDLING, PROPERTY DAMAGE OR SEVERE PERSONAL INJURY AND WILL VOID HENDRICKSON'S WARRANTY.

- DO NOT USE THE SUSPENSION CROSS TUBE AS A JACKING POINT, REFER TO VEHICLE MANUFACTURER FOR PROPER JACKING INSTRUCTIONS.
- ACCEPTABLE LIFTING POINTS FOR A VEHICLE AT THE RATED LOAD INCLUDE BUT ARE NOT LIMITED TO: THE AXLE, EQUALIZING BEAM, AND THE VEHICLE FRAME RAIL. REFER TO THE VEHICLE MANUFACTURER FOR PROPER JACKING INSTRUCTIONS.



**DO NOT** grease or lubricate the cross tube or the center bushing and **DO NOT** use the cross tube as a jacking point, see Figure 6-1.

**FIGURE 6-1**  
ULTIMAAX  
52K lb Capacity Shown



### VISUAL INSPECTION

#### NOTE

A bent cross tube may cause misalignment of the axles, which may cause abnormal tire wear.

- Visually inspect the overall condition of the cross tube for any dents, dings, or bent condition. Clean the cross tube and inspect it for cracks or excessive wear 8" to 10" from each end where it enters into the equalizing beam center bushings. Replace as necessary. Rust and fretting are normal conditions because the cross tube is not fixed and allows relative motion.
- Use a straight edge to inspect the straightness of the cross tube, replace as necessary. If there is a doubt as to fracture, wear or straightness, replacement is necessary.

### EQUALIZING BEAM ASSEMBLY

Periodic visual inspection of equalizing beam assembly is recommended by the driver and service personnel. Check the overall condition of the equalizing beam for any dents, dings, or other damage.

#### AREAS OF INSPECTION

- **Equalizing Beam End Connection** – Bar Pin Style 46K • 52K, Adapter Style 60K • 70K
- **Equalizing Beam End Axle Brackets** – Bar Pin Style 46K • 52K, Adapter Style 60K • 70K
- **Equalizing Beam Center Bushing**

### EQUALIZING BEAM END CONNECTION

An inspection of the equalizing beam end connections are necessary **when a vehicle is in the shop for major repair work** and at regular preventive maintenance intervals. Check the beam end connections for tearing or extreme bulging and for any metal-to-metal contact in the bushed joints.

#### SERVICE HINT

An equalizing beam end connection that is visibly cleaner than the other connections may indicate a loose connection.



## ■ Bar Pin Style 46,000•52,000 Pound Capacity

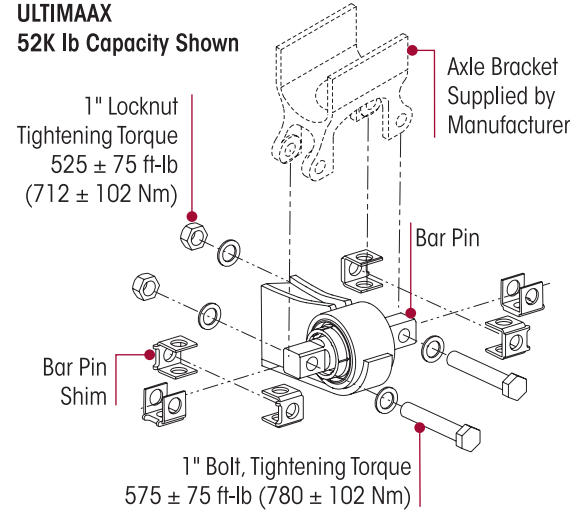
### NOTE

The equalizing beam end connection requires that the fasteners are tightened to torque specifications, see Figure 6-2, to maintain the clamp load of the axle bracket legs to the bar pin. All bushing motion is accommodated by rubber deflection.

### VISUAL INSPECTION

1. Check the wheels.
2. Visually inspect suspension components for signs of movement or excessive wear.
  - Inspect alignment shims in equalizing beam end for looseness. Lightly tap on the alignment shims to see if they can be moved. If movement is detected, tighten fasteners to the proper torque value, see Figure 6-2.
  - Inspect the equalizing beam end connection for signs of excessive wear or looseness.
  - Look for worn, frayed or distorted rubber in the bar pin beam end bushing, see Figure 6-3.
  - Look for the equalizing beam to be lower in the beam hanger, see Figure 6-3.
  - If the bar pin beam end bushing is visually offset a floor jack test should be performed, refer to Jack Test in this section.

**FIGURE 6-2**  
ULTIMAAX  
52K lb Capacity Shown



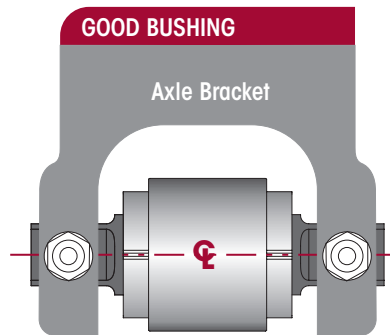
### JACK TEST

1. Place a jack under each beam end as shown. Raise the jack to check for movement in the connection, see Figure 6-4.

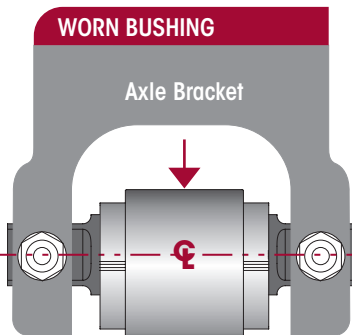
### NOTE

The gap at each side of the visible rubber on the lower part of the end bushing is normal and is not an indication to replace the bushing. Because all rubber end bushings are in compression, with the load bearing on the top side, the lower side of the rubber is slightly relieved, allowing the rubber to move inward, and a gap appears.

**FIGURE 6-3**

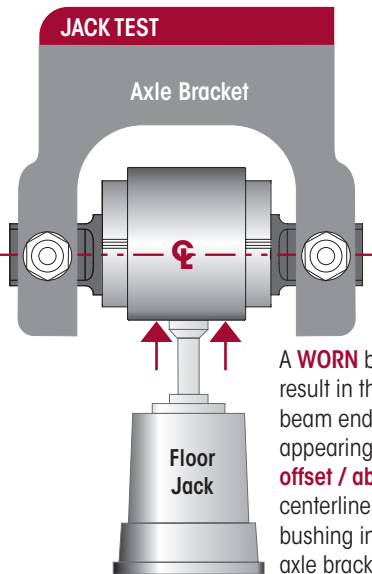


A **GOOD** bushing will result in the equalizing beam end hub appearing to be **centered** with the centerline of the end bushing in the axle bracket



A **WORN** bushing will result in the equalizing beam end hub appearing to be  $\frac{5}{8}$ " (15 mm) **offset / below** the centerline of the end bushing in the axle bracket

**FIGURE 6-4**



A **WORN** bushing will result in the equalizing beam end hub appearing to be **offset / above** the centerline of the end bushing in the axle bracket



**WARNING**

**PHYSICAL INSPECTION**

IF BAR PIN MOVEMENT OR LOOSENESS IS NOTED IN ANY OF THE EQUALIZING BEAM END HUBS, DO NOT OPERATE THE VEHICLE. REPLACE THE RUBBER END BUSHINGS AND ALL CONNECTING PARTS IF NECESSARY. THE ABOVE CONDITION CAN RESULT IN COSTLY REPAIR, DOWNTIME, POSSIBLE SEPARATION OF COMPONENTS, ADVERSE VEHICLE HANDLING, PROPERTY DAMAGE, OR PERSONAL INJURY.

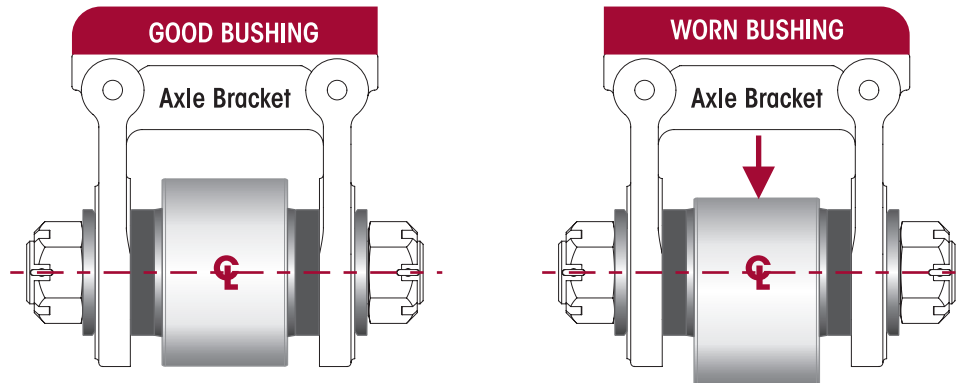
1. If bar pin end bushing movement or looseness is detected in the equalizing beam end hub, replace the end bushings and all connecting parts. Refer to the Component Replacement section of this publication.
2. Check and record torque values, as received, for each 1" bar pin fastener. Correct torque values as required making sure all fasteners are tightened to:
  - At the **locknut** to  $525 \pm 75$  foot pounds torque, or
  - At the **bolt head** to  $575 \pm 75$  foot pounds
3. Recheck equalizing beam end connections for signs of looseness.
  - Inspect alignment shims in equalizing beam end for looseness. Lightly tap on the alignment shims to see if they can be moved. If movement is detected, tighten fasteners to the proper torque value, see Figure 6-2.
  - Inspect equalizing beam end connection for signs of excessive wear or looseness.
4. If bar pin looseness is still detected in any of the equalizing beam end hub, **DO NOT** operate the vehicle. One or more components will require replacement, see Component Replacement section of this publication.

■ **Adapter Style 60,000•70,000 Pound Capacity**

**VISUAL INSPECTION**

1. Chock the wheels.
2. Visually inspect suspension components for signs of movement or excessive wear.
  - Inspect equalizing beam end connection for signs of excessive wear or looseness
  - Look for worn, frayed or distorted rubber in the beam
  - Look for the equalizing beam to be lower in the axle bracket, see Figure 6-5
  - If the adapter style end bushing is visually offset, a floor jack test should be performed, refer to Jack Test in this section
3. The beam end adapter style connections have the flange of the adapter cut off for assembly clearance with the axle housing bowl.

**FIGURE 6-5**



A **GOOD** bushing will result in the equalizing beam end hub appearing to be **centered** with the centerline of the end bushing in the axle bracket

A **WORN** bushing will result in the equalizing beam end hub appearing to be  $\frac{5}{8}$ " (15 mm) **offset/below** the centerline of the end bushing in the axle bracket



- The flat must be positioned vertically as shown in Figure 6-6. If the flat of the adapter position is incorrect, removal of the fasteners will be necessary to correct position, refer to the Adapter Style End Bushings in the Component Replacement section.

## JACK TEST

1. Place a jack under each beam end as shown. Raise the jack to check for movement in the connection or rubber components, see Figure 6-7.

## NOTE

The gap at each side of the visible rubber on the lower part of the bar pin end bushing is normal, see Figure 6-7, and is not an indication to replace the bushing. Because all rubber end bushings are in compression, with the load bearing on the top side, the lower side of the rubber is slightly relieved, allowing the rubber to move inward, and a gap appears.

FIGURE 6-6

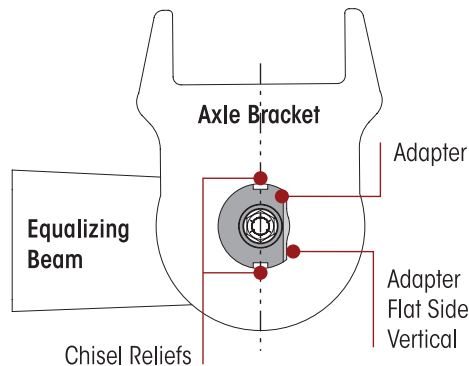
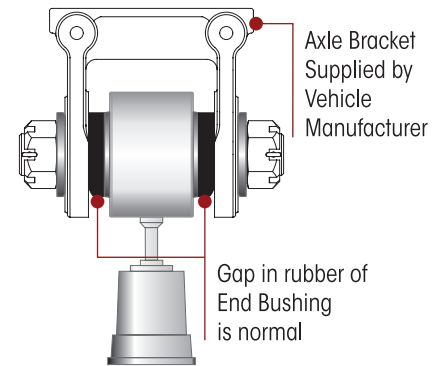


FIGURE 6-7



## PHYSICAL INSPECTION



### WARNING

IF BUSHING MOVEMENT OR LOOSENESS IS NOTED IN THE EQUALIZING BEAM END HUB, DO NOT OPERATE THE VEHICLE. REPLACE THE RUBBER END BUSHINGS AND ALL CONNECTING PARTS. THE ABOVE CONDITION CAN RESULT IN COSTLY REPAIR, DOWNTIME, POSSIBLE SEPARATION OF COMPONENTS, ADVERSE VEHICLE HANDLING, PROPERTY DAMAGE, OR PERSONAL INJURY.

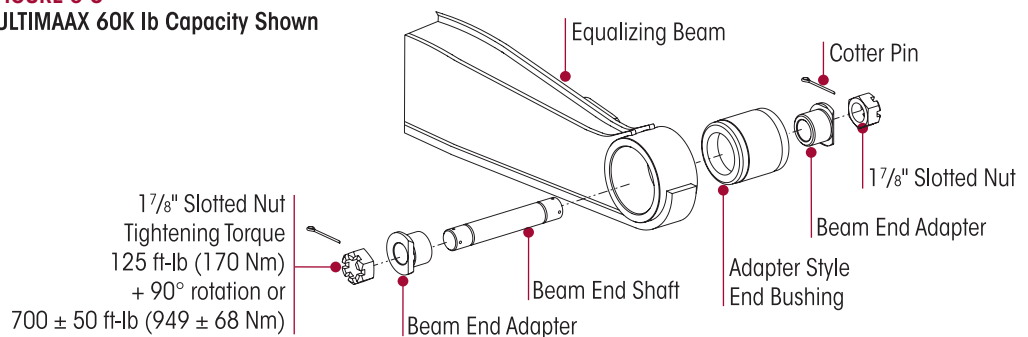
## SERVICE HINT

An equalizing beam end connection that is visibly cleaner than the other connections may indicate a loose connection.

2. If bushing movement or looseness is detected in the equalizing beam end hub, **DO NOT** operate vehicle. Replace the equalizing beam end bushings and all connecting parts. Refer to the Component Replacement section of this publication.
3. Check and record torque values, see Figure 6-8. Correct torque values as required making sure all fasteners are tightened to  $\mathbb{N}$  125 foot pounds + 90° rotation or 700 ± 50 foot pounds torque.

FIGURE 6-8

ULTIMAAX 60K lb Capacity Shown



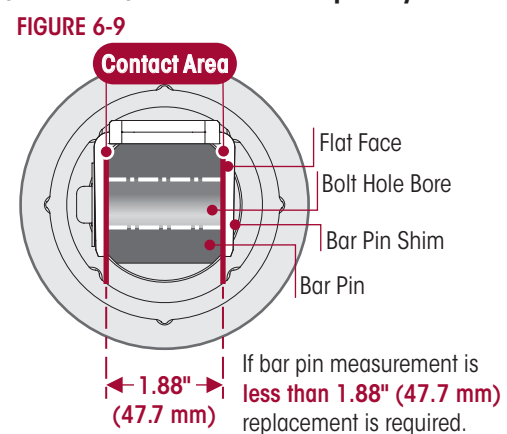


### BEAM END BUSHINGS – Bar Pin Style 46,000•52,000 Pound Capacity

#### VISUAL INSPECTION

An indication that the bar pin end bushing requires replacement is when one or more of the following conditions apply:

- If the contact area, see Figure 6-9 (the flat face area where bar pin contacts the axle bracket) reveal signs of excessive wear. Replace if bar pin thickness measures less than 1.88" (47.7 mm)
- If bar pin bolt holes bores reveal signs of elongation or wear, see Figure 6-9



### BAR PIN SHIMS – 46,000•52,000 Pound Capacity

An indication that the bar pin shims require replacement is when one or more of the following conditions apply:

- Visual inspection of contact area on the shim reveals signs of excessive wear
- The thickness of any single leg on the shim, is less than the measurement shown in Figure 6-10, replacement of bar pin shim is required

FIGURE 6-10

	Part Number 50130-000	Part Number 50131-000	Part Number 57026-000	Original Thickness of Shim Leg	Minimum Thickness Required	Part Number
				1/8" (3.2 mm)	0.123" (3.1 mm)	50131-000
				3/16" (4.8 mm)	0.186" (4.7 mm)	50130-000
				1/4" (6.4 mm)	0.248" (6.3 mm)	50131-000
				3/8" (9.5 mm)	0.371" (9.4 mm)	57026-000

### EQUALIZING BEAM END AXLE BRACKETS

**NOTE**

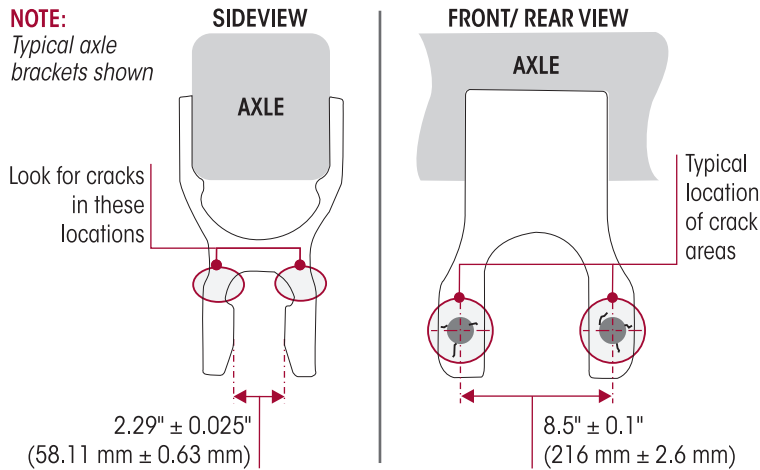
The axle brackets are furnished and welded into position by the vehicle manufacturer or axle manufacturer. Refer to the vehicle manufacturer for inspection, component repair and replacement instructions.

#### INSPECTION

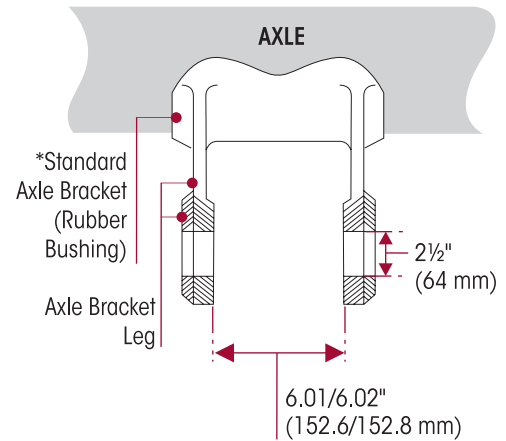
- **BAR PIN STYLE 46,000•52,000 Pound Capacity**
  - a. Inspect the axle brackets for damage or cracks in the locations shown in Figures 6-11 and 6-12. Any axle bracket that is found damaged or cracked must be repaired or replaced.
  - b. Measure the distance between the axle bracket legs for correct width, refer to Figures 6-11 and 6-12 for measurement location and dimensions. An axle bracket outside of the measurement range must be repaired or replaced.
- **ADAPTER STYLE 60,000•70,000 Pound Capacity**
  - a. Inspect the 2 1/2" (64 mm) diameter holes in each of the axle bracket legs, Figure 6-13.
  - b. Remove any burrs or material left there by the old adapters.
  - c. Use a new adapter style bushing as a gauge for fit, being sure it enters the holes from the outside of each bracket leg.
  - d. Measure the distance between the axle bracket legs for correct width, refer to Figure 6-13 for measurement location and dimensions. An axle bracket outside of the measurement range must be repaired or replaced.



**FIGURE 6-11**  
**BAR PIN STYLE AXLE ULTIMAAX 46K • 52K lb Capacity**



**FIGURE 6-13**  
**ADAPTER STYLE AXLE ULTIMAAX 60K • 70K lb Capacity**



## EQUALIZING BEAM CENTER BUSHING

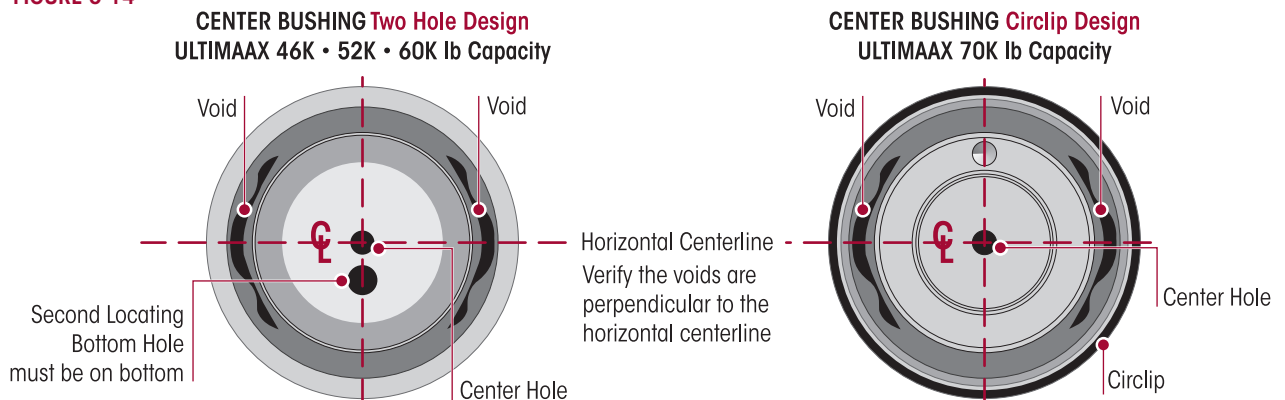
### VISUAL INSPECTION

An inspection of the center bushing is necessary when a vehicle is in the shop for major repair work and at regular preventive maintenance intervals.

**NOTE** ULTIMAAX center bushing is designed with voids at front and rear, see Figure 6-14. These voids are not an indication of wear.

1. Visually inspect the center bushing for signs of movement or excessive wear such as frayed, bulging or distorted rubber in the center bushing.
2. Replacement is necessary if:
  - Any metal to metal contact is visible
  - Any signs that the bushing inner metal is not centered in the bushing
  - Any equalizing beam to saddle contact

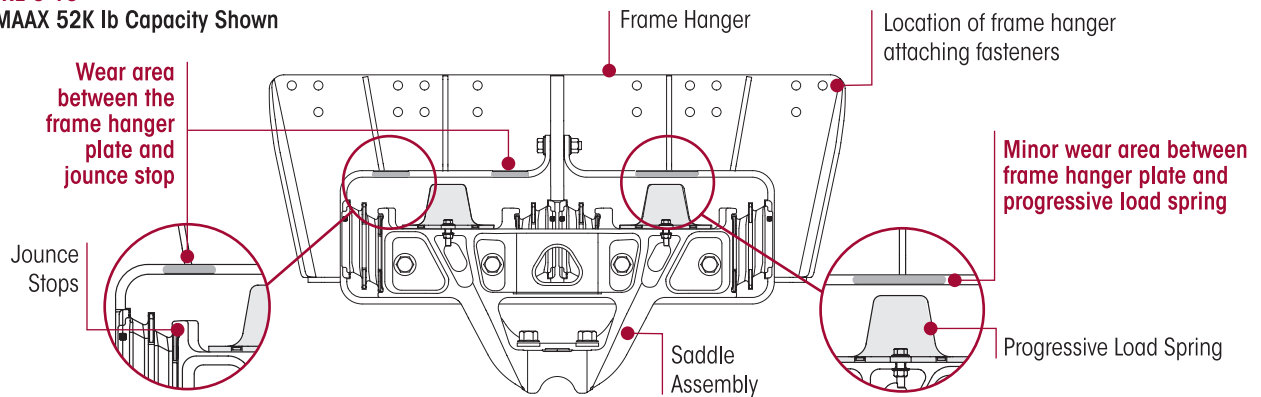
**FIGURE 6-14**



## FRAME HANGER ASSEMBLY

The following points are for guidance and intended to assist personnel in determining when frame hanger assembly maintenance is necessary.

**FIGURE 6-15**  
ULTIMAAX 52K lb Capacity Shown



### INSPECTION

- Inspect the frame hanger for any damage, cracks or signs of adverse or abrasive contact with other components. Some minor wear will be evident where the progressive load spring contacts the frame hanger assembly, see Figure 6-15. If more than half the thickness of the frame hanger plate is damaged or cracked, replace the frame hanger assembly.
- Look for wear in the frame hanger cavity due to contact with the jounce stop, see Figure 6-15. If more than half the thickness of the frame hanger plate is worn or damaged, replace the frame hanger.
- Inspect frame hanger attaching fasteners and frame hanger assembly for signs of looseness or movement. Re-tighten any loose fasteners to specified torque. Components damaged by loose fasteners must be replaced.

## PROGRESSIVE LOAD SPRINGS (PLS)

### NOTE

The Hendrickson ULTIMAAX suspension progressive load springs must be replaced in pairs (left side pairs or right side pairs or rear position pairs or front position pairs), even if only one PLS shows unacceptable conditions. Replacement of only one (1) PLS can cause uneven wear, and higher premature wear for the one replaced.

Visually inspect the progressive load springs at regular preventive maintenance intervals. The following points are for guidance and intended to assist personnel in determining when progressive load spring component requires replacement, refer to the Component Replacement section of this publication.

### SERVICE HINT

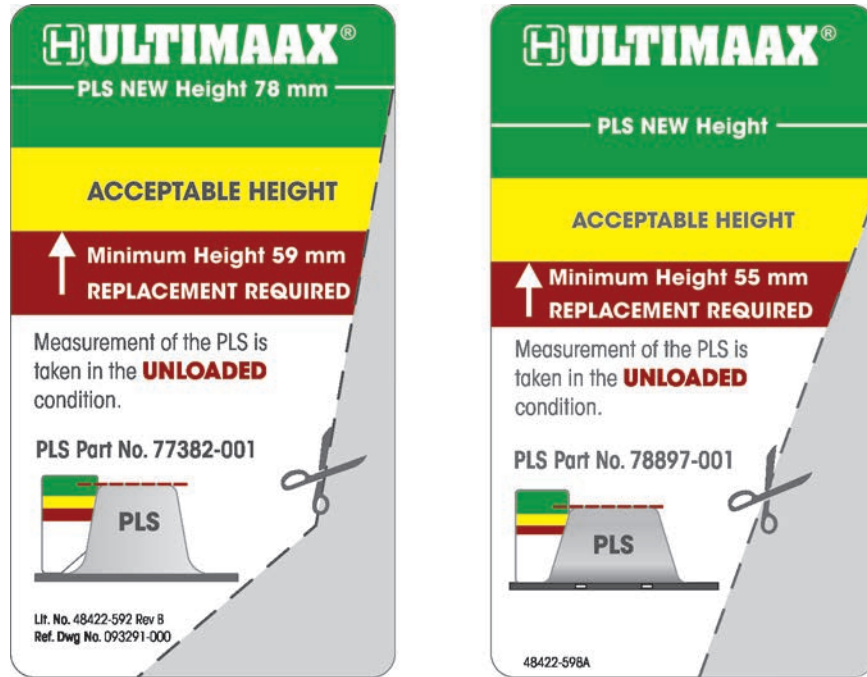
Use **Hendrickson gauge card (Lit. No. 48422-592 for 46K•52K lb capacity)** or **(Lit. No. 48422-598 for 60K•70K lb capacity)** in unloaded condition to help determine the height, length of cut or split and depth of separation of the ULTIMAAX progressive load spring (PLS), see Figure 6-16. These gauge cards are available on-line at [www.hendrickson-intl.com/tools/gauge-request-form](http://www.hendrickson-intl.com/tools/gauge-request-form).

Always inspect the progressive load spring with the vehicle in the **UNLOADED** condition.

- The height of a **new** PLS is:
  - 46K•52K lb Capacity** – 3<sup>1</sup>/<sub>8</sub>" (78 mm) • **60K•70K lb Capacity** – 2<sup>7</sup>/<sub>8</sub>" (73 mm)
- The PLS requires replacement if the height is below, see Figure 6-17:
  - 46K•52K lb Capacity** – 2<sup>5</sup>/<sub>8</sub>" (59 mm) • **60K•70K lb Capacity** – 2<sup>3</sup>/<sub>8</sub>" (55 mm)



FIGURE 6-16



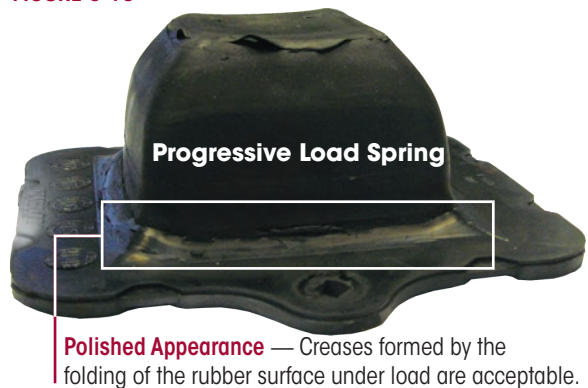
- A bent or cracked mounting base requires PLS replacement.
- If any cuts or splits in the rubber of over 2" (50 mm) in length and an average depth of ½" (13 mm), the effected PLS requires replacement. A certain amount of gradual breakup of the rubber surface is normal. The most probable areas for potential cuts, splits, or wear are shown in Figure 6-17 as "//////".

FIGURE 6-17

Progressive Load Spring (PLS) Height in Unloaded Condition		
CAPACITY (lb)	NEW	MINIMUM
46K • 52K	3 <sup>1</sup> / <sub>16</sub> " (78 mm)	2 <sup>5</sup> / <sub>16</sub> " (59 mm)
60K • 70K	2 <sup>7</sup> / <sub>8</sub> " (73 mm)	2 <sup>3</sup> / <sub>16</sub> " (55 mm)

FIGURE 6-18

- Bonding separation, see Figure 6-17, of the rubber from the bonded rate plate surface to a maximum depth of approximately ½" (13 mm) is acceptable. If the bonding separation depth is ½" (13 mm) or more, the effected PLS requires replacement.
- Creases formed by folding of the rubber surface under load are acceptable. These appear as stripes on the surface, polished by wear or covered with tacky rubber, see Figure 6-18.





## SHEAR SPRINGS

### INSPECTION

Inspect the shear spring with the vehicle in the **UNLOADED** condition.

- Bent or burred edges on the rate plates extending beyond the rubber are acceptable provided the rubber can freely expand during vehicle operation, see Figure 6-19.
- Creases formed by folding of the rubber surface under load are acceptable. These appear as stripes on the surface, polished by wear or covered with tacky (sticky) rubber, see Figure 6-20.

FIGURE 6-19

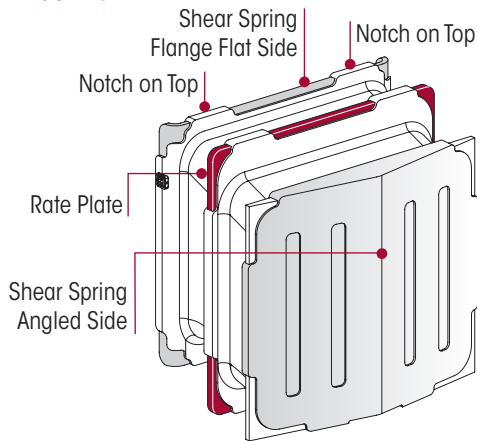
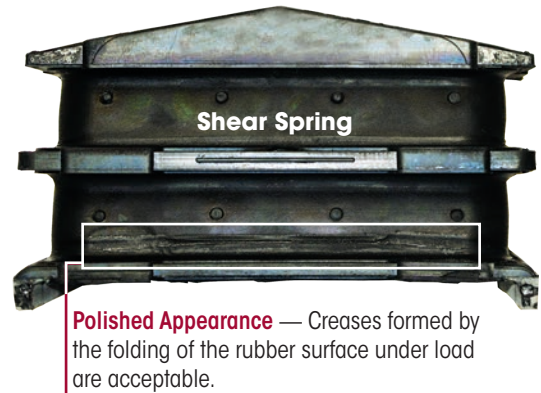


FIGURE 6-20



- Bonding separation of the rubber from any of the bonded rate plate surfaces to a maximum depth of approximately 2" (50 mm) is acceptable, see Figure 6-21. If the bonding separation depth is 2" (50 mm) or more, the shear springs require replacement.
- A certain amount of gradual breakup of the rubber surface is acceptable. Use a feeler gauge to measure cuts or splits in the rubber. If the measurement is over a depth of 2" (50 mm), then the shear springs require replacement, see Figures 6-22 and 6-23.

FIGURE 6-21

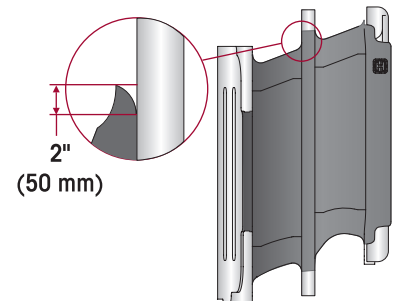


FIGURE 6-22

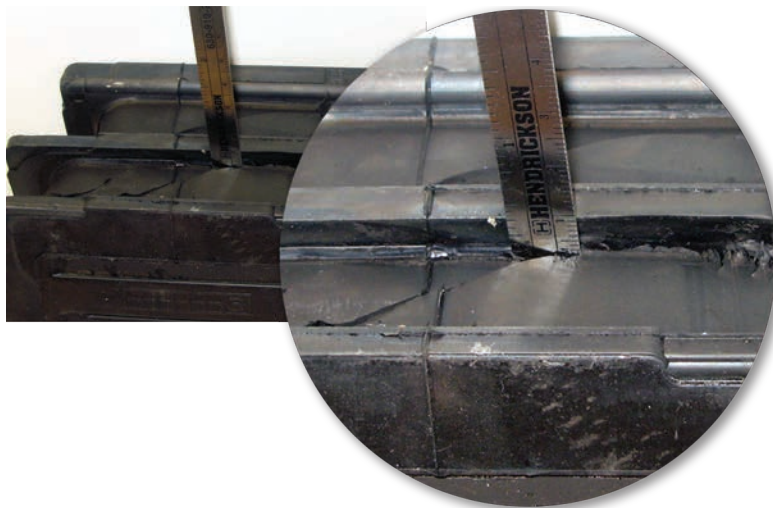
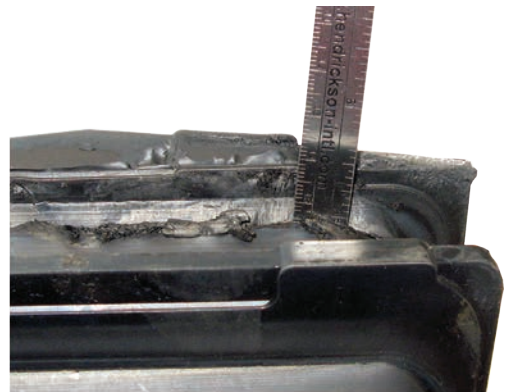


FIGURE 6-23





## SADDLE CONNECTION

Inspect the locknuts for proper torque to prevent wear of the beam center bushing into the saddle. See Torque Specification section of this publication for recommended torque requirements

Visually inspect for any signs of movement or looseness and ensure:

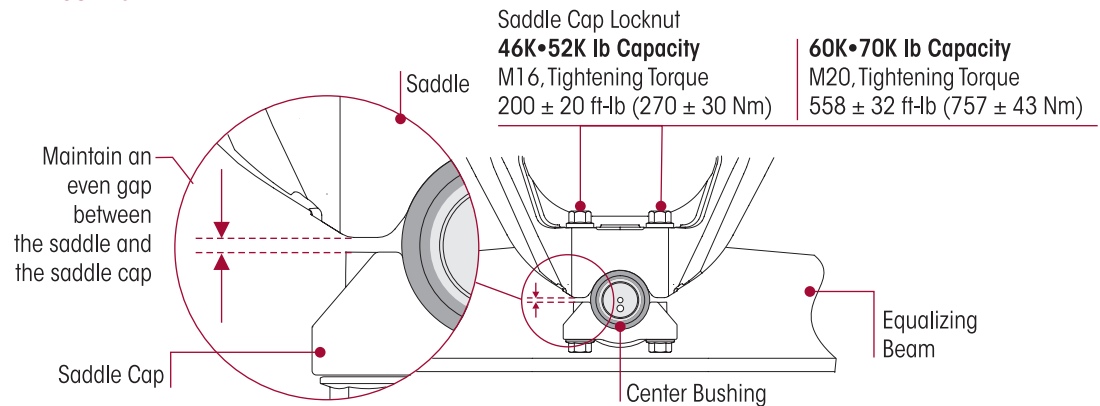
- Each saddle is centered on each equalizing beam center bushing
- The center bushing inner metal is fully seated to the saddle

**Saddle cap fasteners** — While tightening the saddle cap fasteners maintain an even gap between the saddle and saddle cap, see Figure 6-24.

### NOTE

Tightening the saddle cap fasteners properly will help prevent wear of mating components.

**FIGURE 6-24**



## SHOCK ABSORBER INSPECTION

### NOTE

It is not necessary to replace the shock absorbers in pairs if one (1) shock absorber requires replacement.

Hendrickson uses a long service life, premium shock absorber for use on ULTIMAAX suspensions. When the shock absorber replacement is necessary, Hendrickson recommends that the shock absorbers be replaced with identical Hendrickson Genuine parts for servicing. Failure to do so will affect the suspension performance, durability, and will void any applicable warranty. See vehicle manufacturer's applicable publications for other shock absorber inspection requirements.

Inspection of the shock absorber can be performed by doing a heat test and a visual inspection. Replace as necessary, refer to the Component Replacement section of this publication.

### HEAT TEST AND PHYSICAL INSPECTION

1. **Heat Test:** Drive the vehicle at moderate speeds on a rough road for minimum of fifteen minutes.



**WARNING**

DO NOT GRAB THE SHOCK ABSORBER AS IT COULD POSSIBLY BE HOT AND CAUSE PERSONAL INJURY.

2. Perform heat test by carefully touching or placing a hand near the shock absorber body below the dust cover. Touch the frame to get an ambient reference, see Figure 6-25. A shock absorber that is warm to the touch is acceptable, a cold shock absorber should be replaced.

**FIGURE 6-25**





3. **Physical Inspection:** To inspect for an internal failure, remove and shake the suspected shock absorber. Listen for the sound of metal parts rattling inside. Rattling of metal parts can indicate that the shock absorber has an internal failure and the shock absorber should be replaced.

**VISUAL INSPECTION**

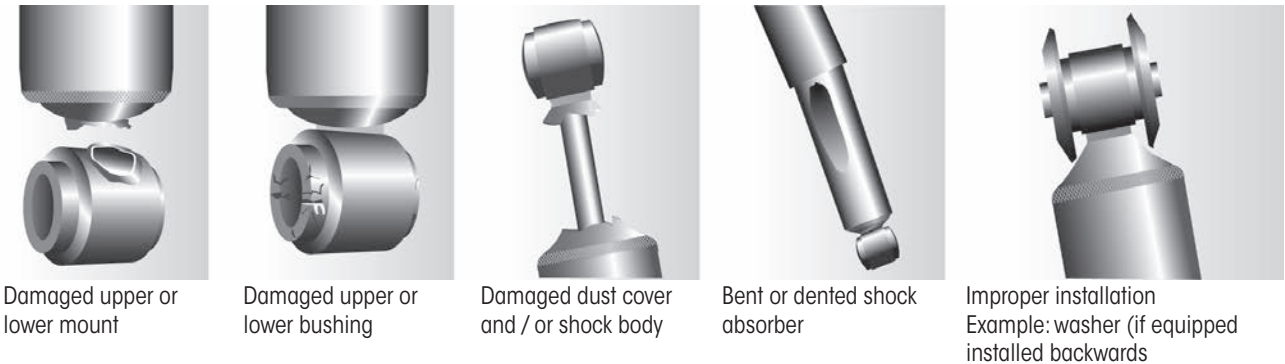
Inspect the shock absorbers in their fully extended position, be sure to look for any of the following potential conditions during the visual inspection. Replace as necessary.

**NOTE**

Figure 6-26 shows a general representation of an unacceptable shock absorber. Refer to your specific model's inspection guidelines for more details.

**FIGURE 6-26**

**SHOCK ABSORBER VISUAL INSPECTION - UNACCEPTABLE CONDITIONS**



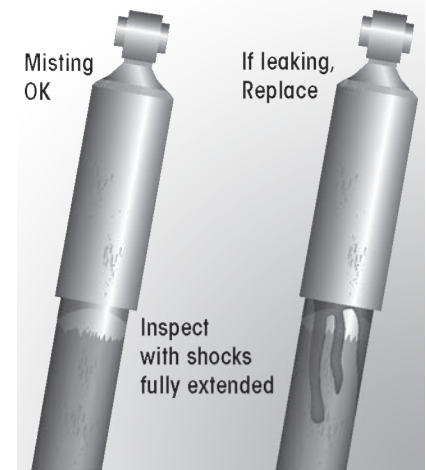
**FIGURE 6-27**

**MISTING vs LEAKING**

**LEAKING VS. MISTING VISUAL INSPECTION**

The inspection must not be conducted after driving in wet weather or a vehicle wash. Shocks need to be free from water.

Many shock absorbers are often misdiagnosed as failures. Misting is the process whereby very small amounts of shock absorber fluid evaporate at a high operating temperature through the upper seal of the shock absorber. When the "mist" reaches the cooler outside air, it condenses and forms a film on the outside of the shock absorber body. Misting is perfectly normal and a necessary function of the shock absorber. The fluid which evaporates through the seal area helps to lubricate and prolong the life of the seal.



**NOTE**

The ULTIMAAX suspension uses a premium seal on the shock absorber, if equipped, however this seal will allow for misting to appear on the shock body (misting is not a leak and is considered acceptable)

Inspect the shock absorber fully extended. **A shock absorber that is truly leaking** will show signs of fluid **leaking in streams from the upper seal**, see Figure 6-27. These streams can easily be seen, underneath the main body (dust cover) of the shock absorber. Replace as necessary.



## WARNING

THIS HENDRICKSON SUSPENSION REQUIRES TORQUE RODS FOR SUSPENSION PERFORMANCE AND VEHICLE STABILITY. IF THESE TORQUE RODS ARE DISCONNECTED OR ARE NON-FUNCTIONAL, DO NOT OPERATE THE VEHICLE. OPERATING A VEHICLE WITH DISCONNECTED OR NON-FUNCTIONAL TORQUE RODS CAN RESULT IN ADVERSE VEHICLE HANDLING, COMPONENT DAMAGE, SUSPENSION/VEHICLE DAMAGE, AND/OR SEVERE PERSONAL INJURY.

### VISUAL INSPECTION

All transverse, longitudinal or V-rod (as applicable) torque rods must be connected and in good working condition when operating the vehicle. Torque rods need to be inspected during preventive maintenance and service for looseness.

**Visually inspect (1) torque rod bushings** for any torn or shredded rubber material interfaces or elongated oval shapes and **(2) torque rods** for any bent, cracked or broken components. The torque rod and/or the torque rod bushings will require replacement if any of these conditions are encountered.

**Torque rod looseness** inspection is necessary. With the vehicle shut down, a lever check can be made with a long pry bar (36") placed under each torque rod end and pressure applied.

**Torque rod length** is determined by the original vehicle manufacturer (see Figure 6-28). The mounting bracket at the axle housing end of the torque rods are furnished and welded into position on the axle housings by the axle or vehicle manufacturer.

### NOTE

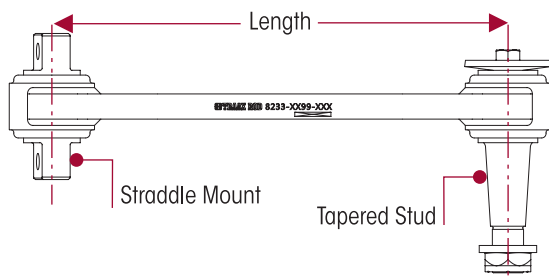
Hendrickson Suspension recommends Grade 8 bolts, hardened flat washer and Grade C locknuts be used for all straddle mount torque rod attachments.

- It is important that the **tightening torque** of the locknuts be checked during preventive maintenance and service. Follow the tightening torque specifications and all applicable preventive maintenance, service and safety instructions issued by the respective vehicle and suspension manufacturers.

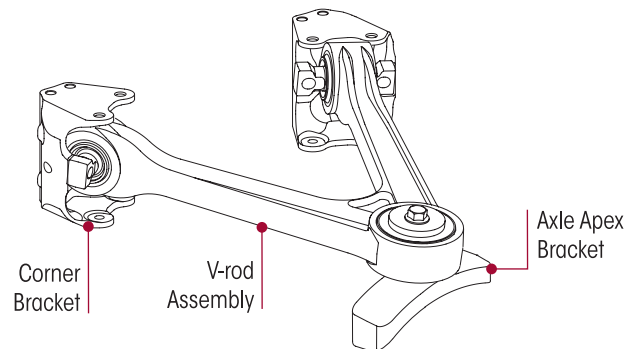
**FIGURE 6-28**

**ULTIMAAX 46K•52K lb Capacity**

**ULTIMAAX 60K•70K lb Capacity Vehicles built after February 2021**



**ULTIMAAX 60K•70K lb Capacity Vehicles built prior to February 2021**





## SECTION 7

# Alignment & Adjustments

## AXLE ALIGNMENT

- **The primary control for axle alignment** is the location of the frame hanger assemblies on the frame rail as installed by the vehicle manufacturer, and the location of the axle brackets on the axles as installed by the axle or vehicle manufacturer.
- **Axle centering and pinion angles** for (1) ULTIMAAX 46,000 to 70,000 pound suspensions originally equipped on vehicles built after February 2021 are controlled by the longitudinal and transverse torque rods, and (2) ULTIMAAX 60,000 • 70,000 pound suspensions originally equipped on vehicles built prior to February 2021 are controlled by the V-rods. All such torque rods are not adjustable.
- **Ride height** is controlled by the design of the suspension frame hanger. No adjustment is possible.

## DRIVE AXLE ALIGNMENT INSPECTION

Proper alignment is essential for maximum ride quality, performance, and tire service life, the recommended alignment procedure is described below. This procedure should be performed if excessive or irregular tire wear is observed.

1. Use a work bay with a level surface.
2. Relax the suspension by slowly moving the vehicle back and forth several times in a straight line without using the brakes. This will slacken or loosen the suspension as the vehicle is positioned. End with all wheels positioned straight ahead.
3. **DO NOT** set the parking brake.
4. Chock the front wheels of the vehicle.
5. Confirm the vehicle is at the correct ride height as per vehicle manufacturer's specifications.
6. Verify all suspension components are in good condition. Repair or replace any worn or damaged suspension components before proceeding with the alignment process.
7. Ensure all drive axle tires are the same size and inflated to the correct tire pressure.
8. Use an alignment machine to calculate the drive axle readings.

### NOTE

Depending on your alignment equipment, enter the vehicle year, make, model and design into the system's computer to determine the vehicle manufacturer's alignment specifications per the alignment equipment instructions. That data will be compared to the vehicle's actual alignment status to determine necessary corrections. Some systems allow you to simply scan the VIN to recall specs. Vehicle manufacturers have set specific alignment specifications.

9. If the measurements are within the vehicle manufacturer's specifications, then the rear drive axle alignment is acceptable. Proceed to check the pinion angles of the drive axles (Step 11).
  - a. If the alignment of the rear drive axle **IS NOT** within the vehicle manufacturer's specifications, then the alignment of this axle **MUST** be corrected **BEFORE** checking the drive axle pinion angles.
  - b. Correct the alignment of this axle by following the Alignment Adjustment instructions as shown in this section.
10. After all drive axles are aligned, check the pinion angle of each drive axle with a digital protractor, see Figure 7-1. Refer to the vehicle manufacturer specifications for the required pinion angles.
  - a. If all pinion angles are within the vehicle manufacturer's specifications then proceed to Step 12.



- b. If any pinion angle is out of the vehicle manufacturer's specifications it must be corrected. Follow the Pinion Angle Adjustment procedure in this section.
11. Recheck measurements to confirm adjustments until the correct alignment and pinion angles are achieved.
12. When all drive axle alignments and pinion angles are within the vehicle manufacturer's specifications then the alignment procedure is complete.
13. Remove the wheel chocks.

## DRIVE AXLE PINION ANGLE ADJUSTMENT

### NOTE

Drive axle pinion angle for vehicles equipped with V-rods is non-adjustable.

Drive axle pinion angles are established by the vehicle manufacturer. If pinion angle adjustment is required, check for proper angles with the vehicle manufacturer. Pinion angle is set by the longitudinal torque rod length.

FIGURE 7-1

### To Check the Pinion Angle

1. Use a work bay with a level floor.
2. Relax the suspension by slowly moving the vehicle back and forth several times in a straight line without using the brakes. This will slacken or loosen the suspension as the vehicle is positioned. End with all wheels positioned straight ahead. Roll to a stop without the brakes being applied. **DO NOT** set the parking brake.
3. Chock the front wheels of the vehicle.
4. Place a digital protractor on the axle housing as shown in Figure 7-1.
5. Check to see if the pinion angle is correct per the vehicle manufacturer's specified range.
6. If necessary, add/remove shims at the longitudinal torque rod connections as required to achieve the proper pinion angle.
7. When the pinion angle is correct tighten all fasteners to the proper torque specifications per the vehicle manufacturer and recheck the pinion angles.
8. Remove wheel chocks.



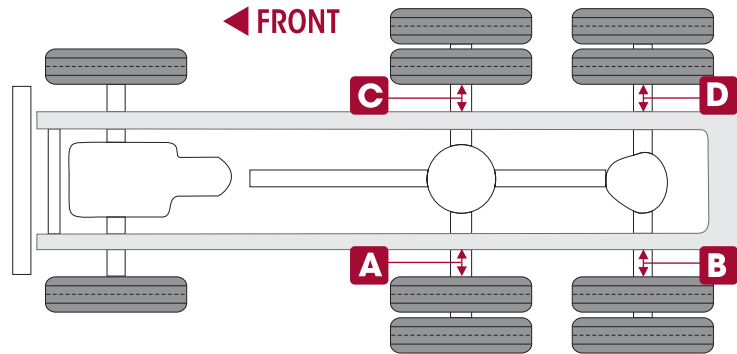
## AXLE LATERAL ALIGNMENT

1. Use a work bay with a level surface.
2. Relax the suspension by slowly moving the vehicle back and forth several times in a straight line without using the brakes. This will slacken or loosen the suspension as the vehicle is positioned. End with all wheels positioned straight ahead. Try to roll to a stop without the brakes being used.
3. **DO NOT** set the parking brake.
4. Chock the front wheels of the vehicle.
5. Measure from the outside of the frame rail to the rim flange of the inner tire. Record the measurement **A** and **B**, see Figure 7-2.
6. Measure the same distance on the opposite side of the same axle. Record the measurement of **C** and **D**, see Figure 7-2.
7. Verify the axle lateral alignment is within the vehicle manufacturer's specifications. Adding or removing shims that are located between the transverse torque rod and the frame rail will normally correct the axle lateral alignment.



- A general rule of thumb is to use a torque rod shim with a thickness that is half of the difference between the two measurements.

FIGURE 7-2



**EXAMPLE**

If the axle lateral alignment is out of specification by 1/4" (6 mm), remove or install a 1/8" (3 mm) torque rod shim between the transverse torque rod and frame rail as needed. Refer to Longitudinal and Transverse Torque Rod section in Preventive Maintenance section of this publication.

**NOTE**

Hendrickson recommends the use of Grade 8 bolts and Grade C locknuts. Washers are not necessary when flanged fasteners are used.

**BAR PIN ALIGNMENT – 46,000•52,000 Pound Capacity**

The alignment feature consists of specially designed, tightly tolerance steel shims which fill the 3/8" (9.5 mm) total gap between the bushing's bar pin and the axle bracket legs. The gap must be filled by placing the shims on the bushing assembly in one of the positions shown in Figure 7-3. Hendrickson has three (3) shim designs options for alignment, part number 50130-000 (provided), 50131-000 and 507026-000, see Figure 7-6.



A BAR PIN SHIM MUST BE INSTALLED AT EACH BOLT LOCATION. THE SAME PART NUMBER SHIM IN THE SAME ORIENTATION MUST BE USED AT BOTH BOLT LOCATIONS ON ANY ONE END BUSHING. DO NOT INSTALL OR STACK MORE THAN ONE (1) SHIM AT EACH BOLT LOCATION. USE GENUINE HENDRICKSON BAR PIN SHIMS, DO NOT USE STANDARD WASHERS. FAILURE TO FOLLOW THESE WARNINGS MAY RESULT IN IMPROPER VEHICLE ALIGNMENT, FRACTURE OF THE AXLE BRACKET OR BAR PIN WHICH COULD RESULT IN THE ADVERSE VEHICLE HANDLING AND POSSIBLE PERSONAL INJURY OR PROPERTY DAMAGE.

**ALIGNMENT ADJUSTMENT**

If alignment of the drive axles is required, as determined by an alignment inspection procedure, the following steps will need to be performed.

1. Determine direction of axle thrust angle. Figure 7-4 illustrates the rear drive axle with a positive thrust angle.

**SERVICE HINT**

Axle movement is in the same direction as the increased shim thickness, see Figure 7-5.

**NOTE**

Computerized alignment equipment is the preferred method of measuring alignment. Laser alignment equipment may be used, however, to calculate the shim thickness required the target offset must be converted to thrust angle, see alignment equipment manufacturer for procedures.

FIGURE 7-3  
ULTIMAAX

52K lb Capacity Shown

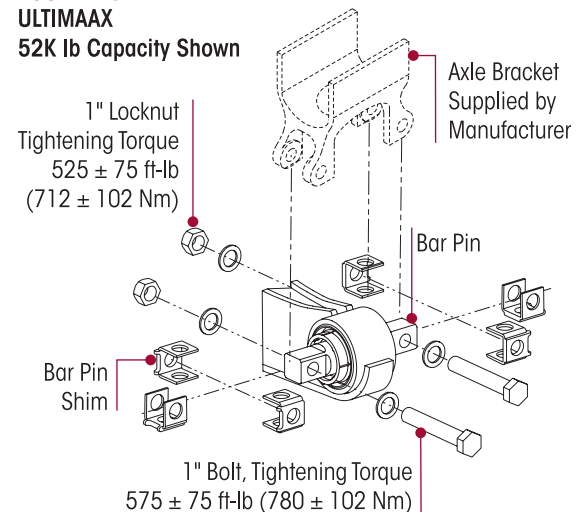
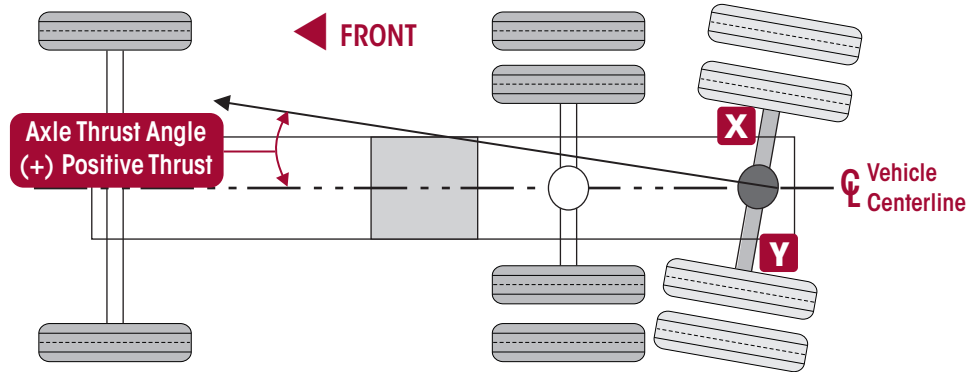




FIGURE 7-4

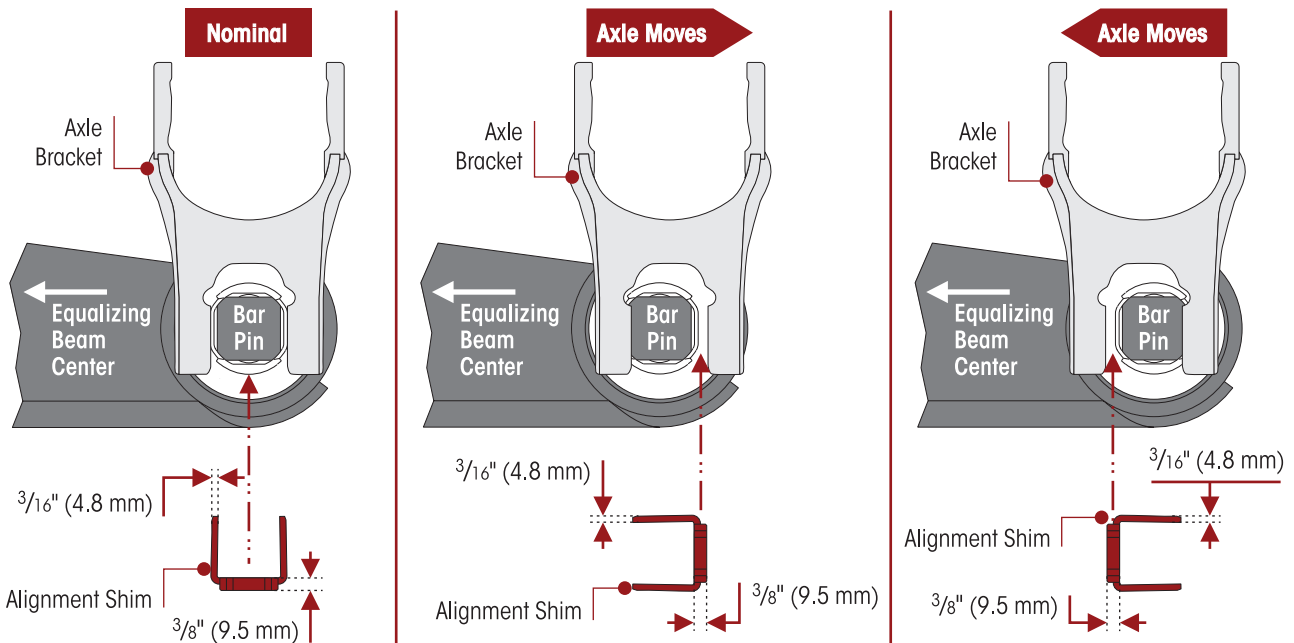


**SERVICE HINT**

Axle adjustment will be on the side of the bar pin where shim thickness is increased. For example, to correct the axle **positive** thrust angle illustrated in Figure 7-4, shim thickness will need to be increased at the **FRONT SIDE** of the bar pin **at Location X** and/or the **BACK SIDE** of the bar pin **at Location Y**.

2. Chock the wheels of the front axles to prevent vehicle movement during service.
3. Raise the frame of the vehicle to remove the load from the suspension.
4. Support the frame with safety stands.
5. Support the equalizing beam and remove the fasteners from the end bushing where the bar pin alignment shim adjustment is being made.
6. Adjust shim thickness to move the axle in the desired direction, see Figure 7-5.

FIGURE 7-5



**WARNING**

EACH EQUALIZING BEAM END BUSHING HAS ONE (1) INBOARD AND ONE (1) OUTBOARD ALIGNMENT SHIM, FOR A TOTAL OF FOUR (4) SETS OF TWO (2) ALIGNMENT SHIMS PER SUSPENSION. EACH SET OF ALIGNMENT SHIMS FOR A PARTICULAR BEAM END BUSHING MUST BE INSTALLED IN THE SAME ORIENTATION. SHIM ORIENTATION MAY DIFFER FOR EACH BEAM END BUSHING, SEE FIGURE 7-3. FAILURE TO FOLLOW THESE WARNINGS MAY RESULT IN THE FRACTURE OF EITHER THE AXLE BRACKET OR BAR PIN WHICH COULD RESULT IN THE ADVERSE VEHICLE HANDLING AND POSSIBLE PERSONAL INJURY OR PROPERTY DAMAGE.



**WARNING**

THE BAR PIN ALIGNMENT SHIM (PART NO. 50130-000) MUST BE INSTALLED WITH THE FOLDED EDGE FACING AWAY FROM THE BUSHING, SEE FIGURE 7-6. FAILURE TO DO SO MAY RESULT IN SHIM DAMAGE, IMPROPER ALIGNMENT, DAMAGE OR FRACTURE OF THE AXLE BRACKET OR BAR PIN WHICH COULD RESULT IN THE ADVERSE VEHICLE HANDLING AND POSSIBLE PERSONAL INJURY OR PROPERTY DAMAGE.

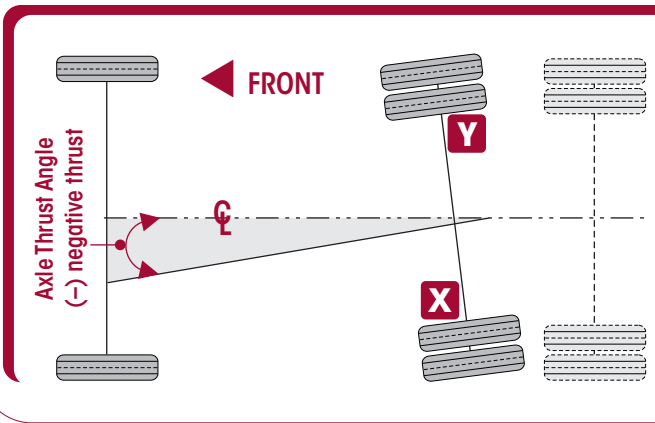
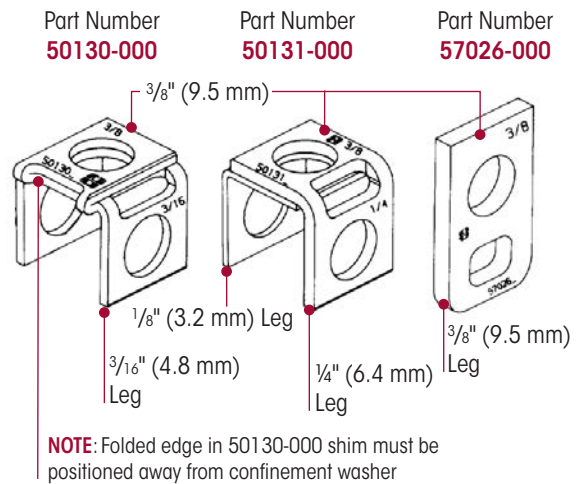
7. Install new end bushing fasteners and tighten to:
  - At the **locknut** to  $\mathbb{R}$  525 ± 75 foot pounds torque, or
  - At the **bolt head** to  $\mathbb{R}$  575 ± 75 foot pounds torque
8. Remove support and lower the vehicle.
9. Verify the axles' alignments are within the vehicle manufacturer's tolerance.
10. Set brakes and remove wheel chocks.

FIGURE 7-6

**BAR PIN ALIGNMENT SHIMS**

The following service notes will help when performing Hendrickson equalizing beam bar pin alignment

- The standard alignment shims supplied with each suspension (P/N 50130-000) have two  $\frac{3}{16}$ " legs and a  $\frac{3}{8}$ " back. Rotating the shim pairs 90° will change the axle alignment in ±  $\frac{3}{16}$ " increments. If a finer adjustment is required use alignment shim (P/N 50131-000). This alignment shim has one  $\frac{1}{8}$ " leg, one  $\frac{1}{4}$ " leg, and a  $\frac{3}{8}$ " back. A total of  $\frac{3}{4}$ " adjustment is achievable to the axle. A  $\frac{3}{8}$ " flat shim is also available (P/N 57026-000).
- $\frac{1}{16}$ " shim thickness increases 0.10° of thrust angle.
- To accomplish a thrust angle adjustment rotate the alignment shims on the bar pin of the end bushing. Axle movement will be in the direction of the shim thickness increase.
- Axle thrust angle may be adjusted at either wheel end on an axle. If insufficient adjustment is available at one wheel end, the opposing wheel end will also need to be adjusted, but in the opposite direction.



**Example:** The alignment equipment shows the front drive axle to have a **0.40° Negative thrust angle** to the left. This will require a  $\frac{1}{4}$ " shim thickness increase to the **FRONT SIDE** of the left front equalizing beam end bushing bar pin. If there is less than  $\frac{1}{4}$ " of adjustment available at this location then some of the adjustment will have to be made at the **REAR SIDE** of the right front end bushing bar pin. In this case a  $\frac{1}{8}$ " shim thickness increase at the **FRONT SIDE** of the left front bar pin **AND** a  $\frac{1}{8}$ " shim thickness increase at the **REAR SIDE** of the right front bar pin will correct the 0.40° negative thrust angle.

**ADAPTER STYLE BUSHING ALIGNMENT – 60,000 Pound Capacity**

**NOTE**

Contact Hendrickson Tech Services for assistance at 855-743-3733, 630-910-2800 or e-mail: [wdtechservices@hendrickson-intl.com](mailto:wdtechservices@hendrickson-intl.com)



## SECTION 8 Component Replacement

### FASTENERS

When servicing an ULTIMAAX suspension, Hendrickson recommends replacing all removed fasteners with new genuine Hendrickson fasteners. Maintain correct torque values at all times. Check torque values as specified, see Hendrickson's Torque Specifications section of this publication. If non-Hendrickson fasteners are used follow torque specifications listed in the vehicle manufacturer's service manual.

**NOTE** Torque values shown in this publication apply only if Hendrickson supplied fasteners are used. If non Hendrickson fasteners are used, follow the torque specification listed in the vehicle manufacturer's service manual.

### SHOCK ABSORBER

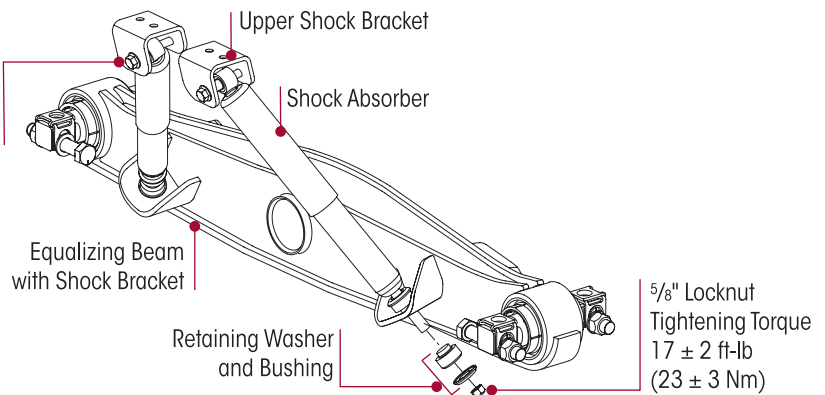
**NOTE** It is not necessary to replace shock absorbers in pairs if one shock absorber requires replacement.

#### DISASSEMBLY

1. Chock the front wheels of the vehicle.
2. Remove the lower shock absorber nylon locknut, retainer washer and rubber bushing from the shock absorber stud, see Figure 8-1.
3. Remove the upper shock fasteners from the upper shock bracket, see Figure 8-1.
4. Remove shock absorber.

**FIGURE 8-1**  
ULTIMAAX 52K lb Capacity Shown

M16 Upper Shock Bracket Fasteners  
Tightening Torque  
 $170 \pm 20$  ft-lb ( $231 \pm 27$  Nm)



#### ASSEMBLY

1. Mount the shock absorber in the upper shock bracket and install fasteners, tighten to  $\mathbb{R}$   $170 \pm 20$  foot pounds torque, see Figure 8-1.
2. Locate the shock absorber stud in the lower shock bracket and install the rubber bushing, retainer washer and nylon locknut. Tighten to  $\mathbb{R}$   $17 \pm 2$  foot pounds torque, see Figure 8-1.
3. Remove the wheel chocks.



## SHEAR SPRING / FRAME HANGER ASSEMBLY / SADDLE ASSEMBLY

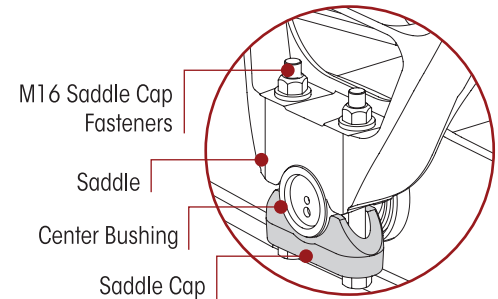
You will need:

- **Saddle Disassembly Tool** Part No. 66086-113L and **Saddle Assembly Tool** Part No. 66086-108L, refer to the Special Tools section of this publication.

### DISASSEMBLY

1. Chock the front wheels of the vehicle.
2. Raise and support the drive axles on safety stands.
3. Remove the drive tires from the side of the vehicle being serviced.
4. Remove and discard the M16 saddle cap fasteners that attach the saddle assembly to the center bushing, see Figure 8-2.
5. Raise the vehicle's frame just enough to create a 1/2" (13 mm) gap between the saddle assembly and center bushing. Support the vehicle's frame at this height on safety stands.
6. Remove the progressive load springs M10 fasteners and discard, see Figure 8-4.
7. Remove the progressive load springs.
8. Apply NLGI #2-EP (Extreme Pressure) chassis lubricant to the threaded rod of the Saddle Disassembly Tool Part No. 66086-113L, see Figure 8-3.

FIGURE 8-2



### NOTE

The threaded rod spacer and spacer nut are designed and orientated to fit into the saddle assembly openings, see Figure 8-5.

9. Install both Saddle Disassembly Tool on each end of one (1) saddle assembly, rotate the threaded rod blocking nuts until each are oriented properly into the saddle assembly openings, see Figures 8-4 and 8-5.

FIGURE 8-3

**Saddle Disassembly Tool**  
Hendrickson Part No. 66086-113L

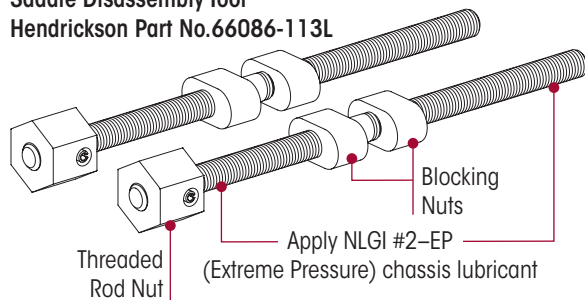


FIGURE 8-4

**ULTIMAAX 52K lb Capacity Shown**

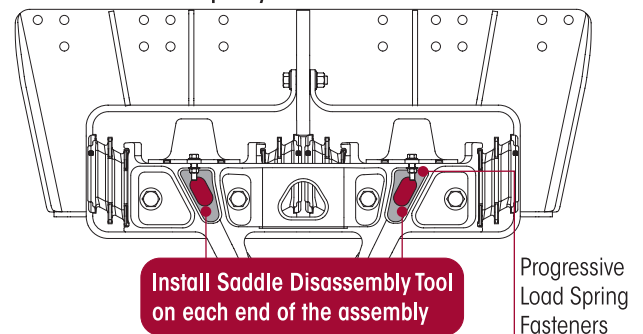
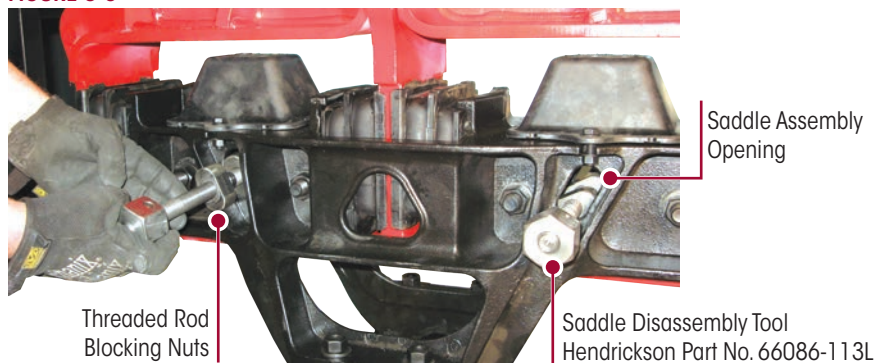


FIGURE 8-5





## SERVICE HINT

Use ratchet strap attached to each saddle half and the frame or vehicle body to secure the saddle halves during removal.

10. Snug the Saddle Disassembly Tool.

## NOTE

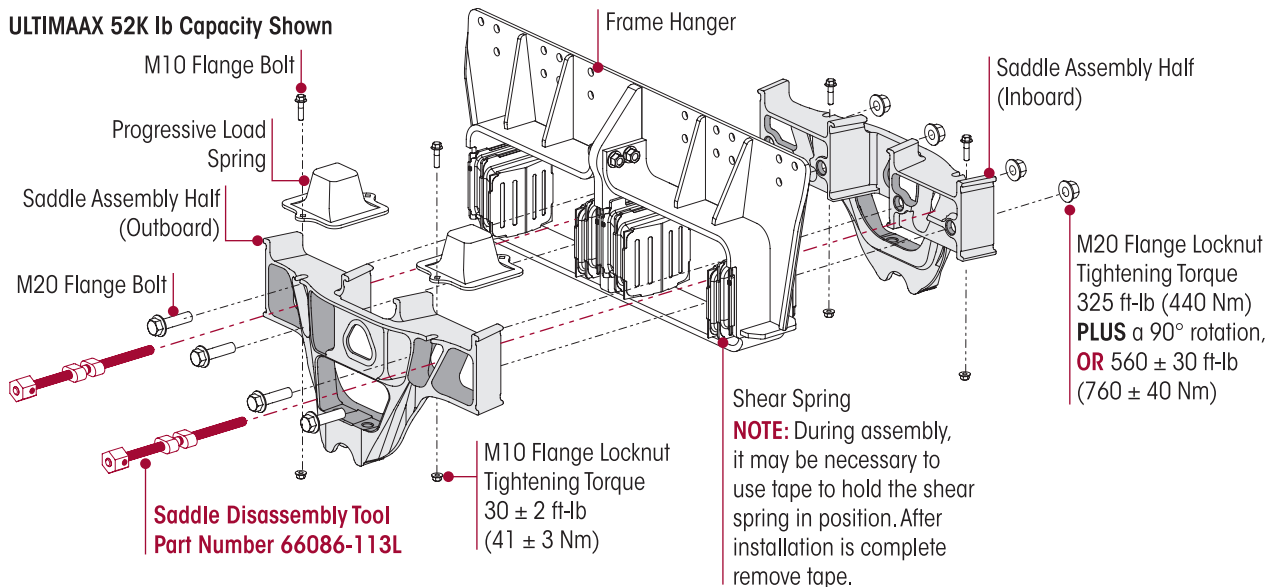
The shear springs in each frame hanger are compressed when installed.

11. Remove and discard the M20 saddle fasteners, see Figure 8-6.

12. To separate the two (2) saddle halves, evenly rotate the threaded rod nut to tighten the Saddle Disassembly Tool, see Figure 8-6.

**FIGURE 8-6**

**ULTIMAAX 52K lb Capacity Shown**



13. Remove the saddle halves and / or shear springs for replacement.



EACH FRAME HANGER ASSEMBLY WEIGHS APPROXIMATELY 108 POUNDS (49 KILOGRAMS), USE APPROPRIATE LIFTING DEVICES TO REMOVE OR INSTALL THE FRAME HANGER ASSEMBLY. FAILURE TO DO SO CAN RESULT IN DAMAGE TO THE VEHICLE OR PERSONAL INJURY.

14. If replacing the frame hanger, remove the frame fasteners per the vehicle manufacturer's instructions. Remove frame hanger.

## ASSEMBLY

1. If installing a new frame hanger continue to Step 2. If installing or servicing shear springs or saddle assembly, proceed to Step 3.



EACH FRAME HANGER ASSEMBLY WEIGHS APPROXIMATELY 108 POUNDS (49 KILOGRAMS), USE APPROPRIATE LIFTING DEVICES TO REMOVE OR INSTALL THE FRAME HANGER ASSEMBLY. FAILURE TO DO SO CAN RESULT IN DAMAGE TO THE VEHICLE OR PERSONAL INJURY.

2. Position the frame hanger assembly against the frame rail. Install fastener's per the vehicle manufacturer's instructions and specifications.

## SERVICE HINT

During assembly, it may be necessary to use tape to hold the shear springs in position. After installation is complete, remove tape.

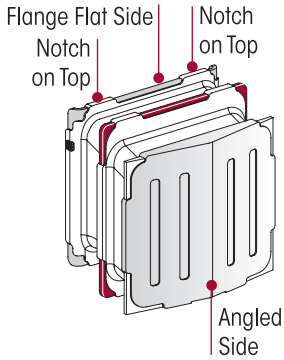
3. Position the shear springs with the flanged flat side against the frame hanger with the shear spring angled downward, see Figure 8-7.

4. Apply NLGI #2-EP (Extreme Pressure) chassis lubricant to the threaded rod of the Saddle Assembly Tool Part No. 66086-108L, see Figure 8-8.

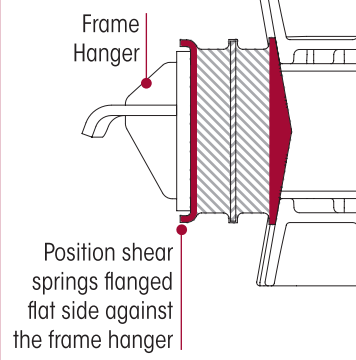


**FIGURE 8-7**  
ULTIMAAX 52K lb Capacity Shown

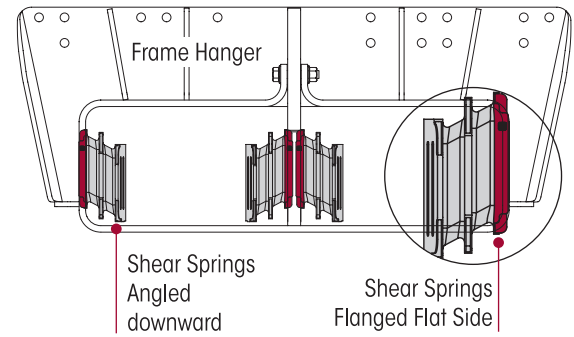
**SHEAR SPRING**



**TOP VIEW**



**SIDE VIEW**

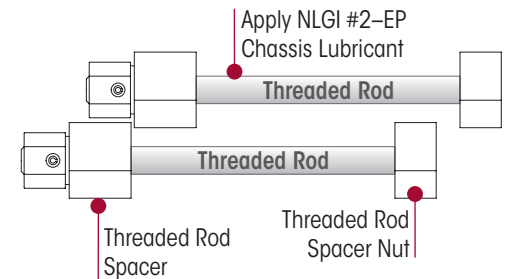


**NOTE**

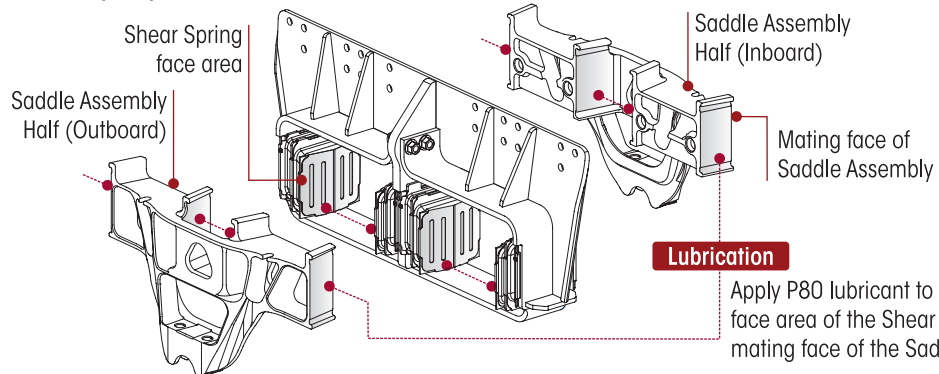
The threaded rod spacer and spacer nut are designed and orientated to fit into the saddle assembly openings.

5. Apply P-80 lubricant to the shear spring's angled face and to the mating face of the saddle halves, see Figure 8-9.
6. On each side of the saddle assemblies, rotate the threaded rod spacers and spacer nuts of the saddle assembly tool until each are oriented properly into the saddle assembly openings, see Figure 8-10.

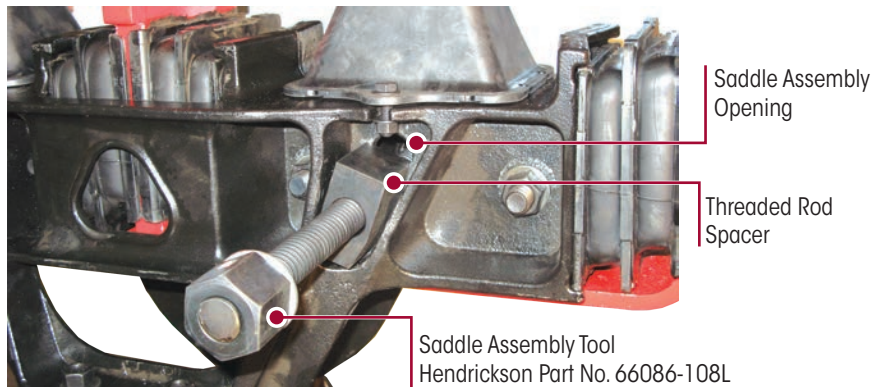
**FIGURE 8-8**  
Saddle Assembly Tool  
Hendrickson Part No. 66086-108L



**FIGURE 8-9**  
ULTIMAAX  
52K lb Capacity Shown



**FIGURE 8-10**



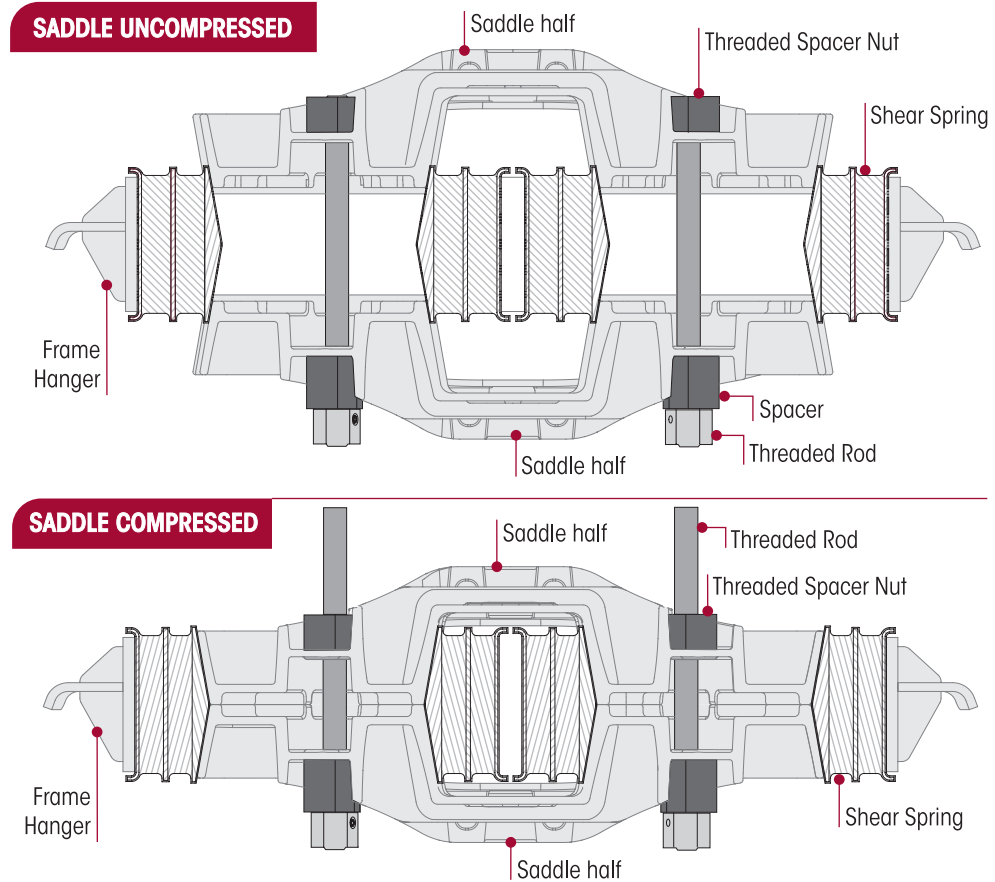


## SERVICE HINT

Use a mechanism to attach to the frame to aid in holding the saddle up while performing procedure (such as a strap or rope) attached to each saddle half and the frame or the vehicle body to secure the saddle halves during installation or have an additional person assist to align the saddle halves properly.

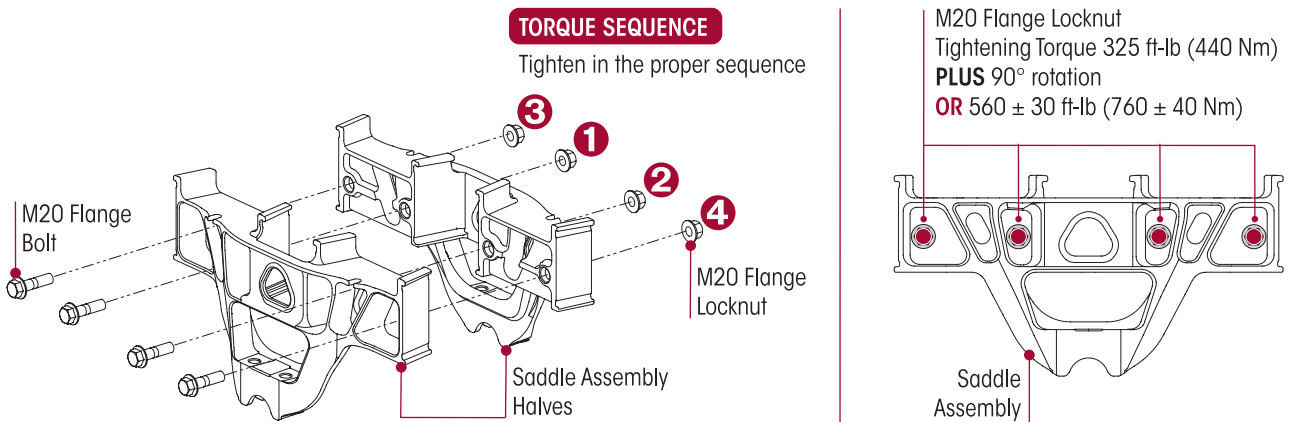
- Position the inner saddle half into the frame hanger along with the shear springs, outer saddle half, see Figure 8-11.

FIGURE 8-11



- Bring both saddle halves together with the Saddle Assembly Tool. Evenly tightening the Saddle Assembly Tool until both saddle halves are seated against each other.
- Install the new M20 saddle fasteners. Tighten in the proper sequence shown in Figure 8-12 to  $\boxed{325}$  325 foot pounds plus a 90° rotation, or 560 ± 30 foot pounds torque.
- Remove temporary tape from the shear springs if used during assembly.
- Remove the Saddle Assembly Tool.

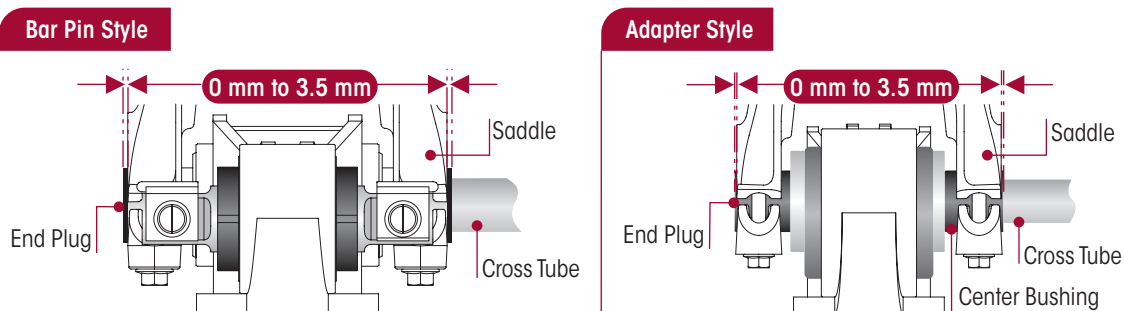
FIGURE 8-12





12. Install the progressive load springs.
13. Install the progressive load spring M10 fasteners. Tighten to  $\mathbb{R}$  30 ± 2 foot pounds torque.
14. Remove the frame safety stands.
15. Lower the frame of the vehicle while engaging and centering the saddles on the equalizing beam's center bushings, see Figure 8-13.

FIGURE 8-13



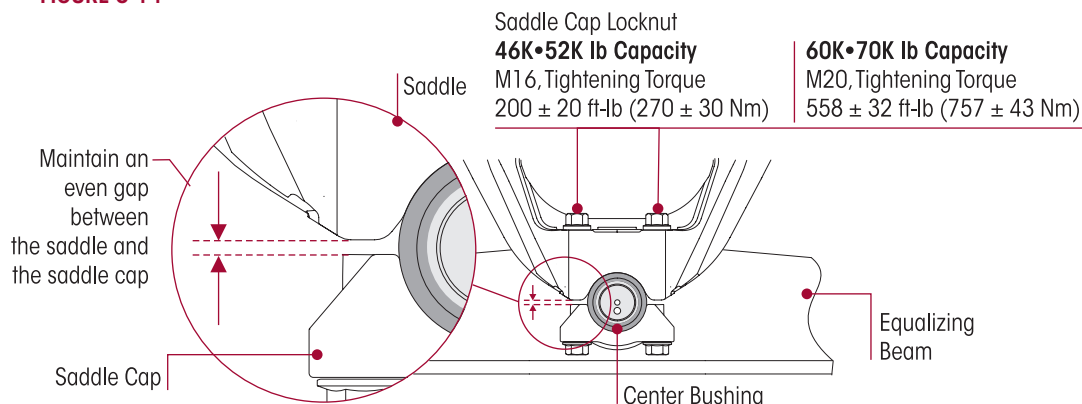
A SADDLE ASSEMBLY IS ATTACHED TO THE CENTER BUSHING OF EACH EQUALIZING BEAM WITH TWO (2) SADDLE CAPS. EACH SADDLE CAP USES TWO (2) BOLTS TO CLAMP THE CENTER BUSHING INNER METAL TO THE SADDLE. EACH SADDLE CAP MUST BE INSTALLED SO THAT THERE IS AN EVEN GAP BETWEEN THE SADDLE CAP AND THE BASE OF THE SADDLE LEGS AS SHOWN IN FIGURE 8-14. IF EACH SADDLE CAP IS NOT INSTALLED EVENLY, THE SADDLE LEGS COULD BECOME DEFORMED, RESULTING IN BENT BOLTS OR DAMAGED SADDLES.

NOTE

Tightening the saddle cap fasteners properly will help prevent wear of mating components, such as the beam center bushing, saddle, and saddle cap.

16. While tightening the saddle cap fasteners, maintain an even gap between the saddle and saddle cap, see Figure 8-14.

FIGURE 8-14

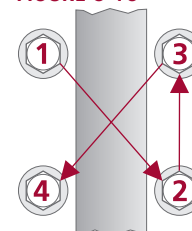


17. Install the saddle cap fasteners and tighten evenly in several steps in proper sequence to achieve uniform bolt tension, see Figure 8-15:

- 46,000 • 52,000 pound capacity –  $\mathbb{R}$  200 ± 20 foot pounds torque
- 60,000 • 70,000 pound capacity –  $\mathbb{R}$  558 ± 32 foot pounds torque

18. Install the tires.
19. Remove supports from the axles and lower the vehicle onto the ground.
20. Remove the wheel chocks.

FIGURE 8-15





## PROGRESSIVE LOAD SPRING (PLS)

### NOTE

The Hendrickson ULTIMAAX suspension progressive load springs must be replaced in pairs (left side pairs or right side pairs or rear position pairs or front position pairs), even if only one PLS shows unacceptable conditions. Replacement of only one PLS can cause uneven wear, and higher premature wear for the one replaced.

### DISASSEMBLY

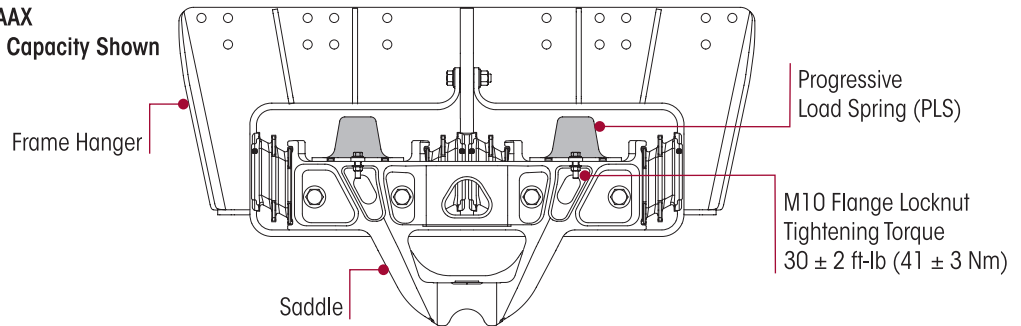
1. Chock the front wheels of the vehicle.
2. Raise the vehicle's frame until the saddle assembly contacts the bottom of the frame hanger assembly. Support the vehicle's frame at this height with safety stands.
3. Remove and discard the M10 fasteners that attach the progressive load springs to the saddle assembly.
4. Remove the progressive load springs from the frame hanger assembly.

### ASSEMBLY

1. Install the progressive load springs into the frame hanger assembly.
2. Install four M10 flange bolts that attach the PLS to the saddle assembly. The flange bolts **must** be installed with the locknuts facing downward as shown in Figure 8-16.
3. Tighten the PLS fasteners to  $30 \pm 2$  foot pounds torque.
4. Remove the frame safety stands and lower the vehicle.
5. Remove the wheel chocks.

**FIGURE 8-16**

**ULTIMAAX**  
**52K lb Capacity Shown**



## EQUALIZING BEAM

### DISASSEMBLY

1. Chock the wheels of the steer axle.
2. Raise and support the drive axles with safety stands.
3. Remove the tires.
4. Support the pinion of the drive axles to prevent axle movement during service.
5. Remove the saddle cap bolts from both inboard and outboard side of each equalizing beam.
6. Remove the saddle caps, see Figure 8-17.
7. Raise the vehicle's frame just enough to create a  $\frac{1}{2}$ " (13 mm) gap between the saddles and the center bushings. Support the vehicle's frame at this height with safety stands.

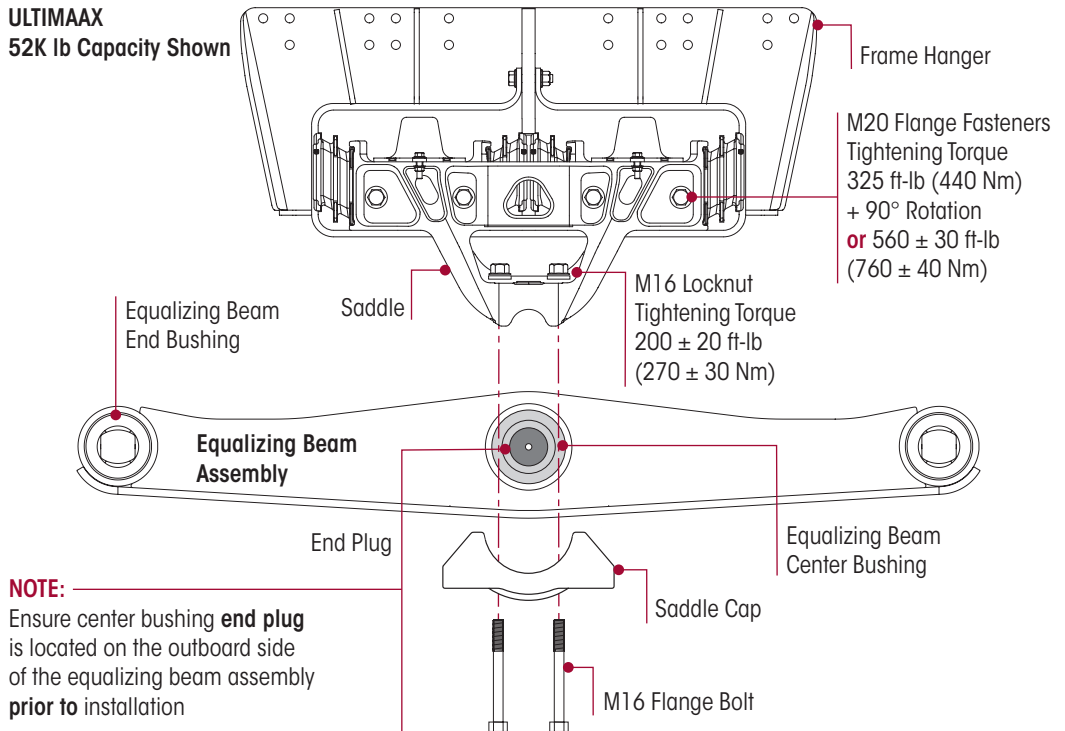


THE WEIGHT OF THE EQUALIZING BEAM ASSEMBLY IS APPROXIMATELY 290 TO 315 POUNDS (131 TO 141 KILOGRAMS). PRIOR TO REMOVING THE END BUSHING BOLTS FROM THE EQUALIZING BEAM, SUPPORT THE END OF THE EQUALIZING BEAM TO PREVENT IT FROM DROPPING. CARE SHOULD BE TAKEN AT REMOVAL AND INSTALLATION TO PREVENT PERSONAL INJURY OR DAMAGE TO COMPONENTS.



**FIGURE 8-17**

**ULTIMAAX**  
52K lb Capacity Shown



**NOTE:**  
Ensure center bushing **end plug** is located on the outboard side of the equalizing beam assembly **prior to installation**

8. Support both equalizing beams with a floor jack.
9. **Adapter Style End Bushing** – Proceed to Step 11.

**NOTE**

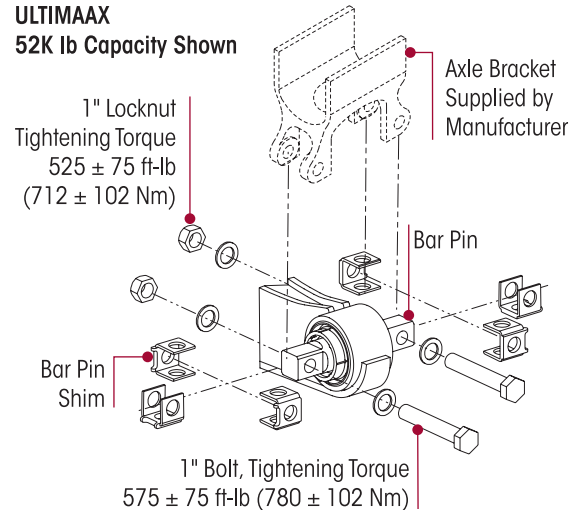
Prior to disassembly of the equalizing beam bar pin fasteners, note the orientation of the bar pin alignment shims, see Figure 8-18. It is required that the bar pin alignment shims are installed in the same orientation and location as removed to preserve the existing vehicle alignment. Improper vehicle alignment can increase tire wear.

10. **Bar Pin Style End Bushing** – Note the orientation and location of the bar pin shims, see Figure 8-18.

11. Remove and discard end bushing fasteners.

**FIGURE 8-18**

**ULTIMAAX**  
52K lb Capacity Shown



**SERVICE HINT**

The center bushing will allow the cross tube and the equalizing beam to angle downward once the equalizing beam end fasteners are removed.

12. Slowly lower the floor jacks and remove the equalizing beams from the axle brackets.



**PRIOR TO REMOVING BOTH EQUALIZING BEAMS, SUPPORT THE PINION OF EACH DRIVE AXLE. FAILURE TO DO SO CAN RESULT IN PERSONAL INJURY OR ALLOW THE AXLES TO SHIFT MAKING REASSEMBLY MORE DIFFICULT.**

13. Slide the equalizing beams off the cross tube and out from under the vehicle.
14. Remove the floor jacks from under the equalizing beams.



## ASSEMBLY

1. Position the equalizing beams under the axles with floor jacks.

### SERVICE HINT

Ensure the equalizing beam's center bushing end plug is located on the outboard side of the equalizing beam, see Figure 8-17.

2. Install the cross tube into the center bushings of both equalizing beams.

### SERVICE HINT

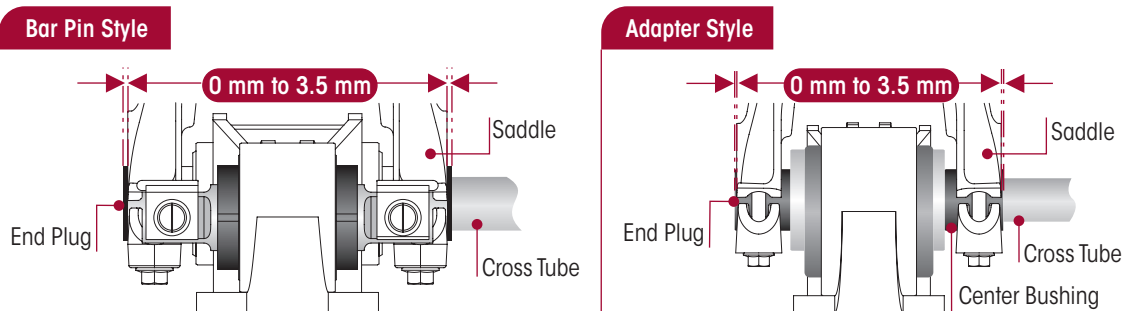
Increasing or decreasing the pinion angle may help align the axle bracket and the equalizing beam end bushings.



THE WEIGHT OF THE EQUALIZING BEAM ASSEMBLY IS APPROXIMATELY 290 TO 315 POUNDS (131 TO 141 KILOGRAMS). CARE SHOULD BE TAKEN AT REMOVAL AND INSTALLATION TO PREVENT PERSONAL INJURY OR DAMAGE TO COMPONENTS.

3. Using the floor jacks, slowly raise both equalizing beams and cross tube as an assembly into the axle brackets. Ensure each equalizing beam end bushing correctly engages its respective axle bracket.
4. **Adapter Style End Bushing 60,000 • 70,000 pound capacity** – Proceed to Step 6.
5. **Bar Pin Style End Bushing 46,000 • 52,000 pound capacity** – Install bar pin shims in the same orientation and location as noted prior to disassembly, see Figure 8-18.
6. Install new equalizing beam end fasteners into both beams. Tighten the equalizing beam end fasteners to:
  - **Adapter Style End Bushing** –  $125 \pm 90^\circ$  rotation or  $700 \pm 50$  foot pounds torque.
  - **Bar Pin Style End Bushing** – at the **locknuts**  $525 \pm 75$  foot pounds or at the **bolt head**  $575 \pm 75$  foot pounds torque

FIGURE 8-19



7. Remove the frame safety stands.
8. Lower the frame of the vehicle while engaging and centering the saddles on the equalizing beam's center bushings, see Figure 8-19.



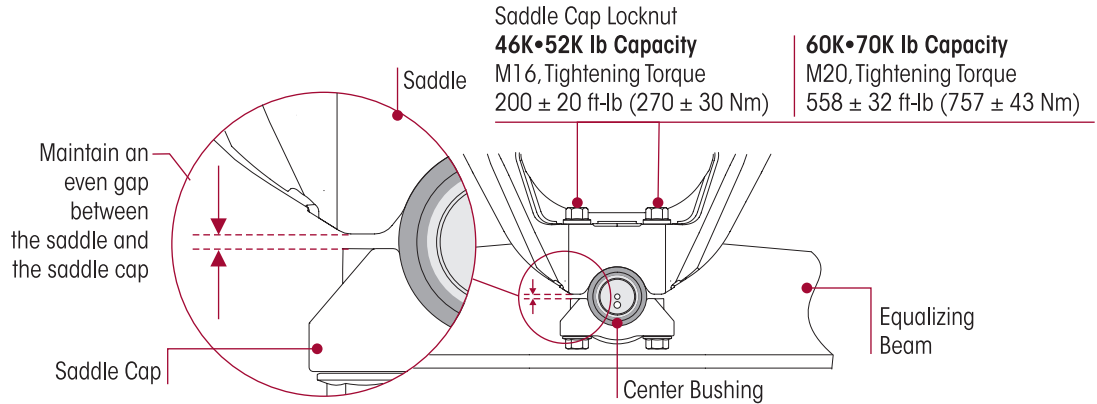
A SADDLE ASSEMBLY IS ATTACHED TO THE CENTER BUSHING OF EACH EQUALIZING BEAM WITH TWO (2) SADDLE CAPS. EACH SADDLE CAP USES TWO (2) BOLTS TO CLAMP THE CENTER BUSHING INNER METAL TO THE SADDLE. EACH SADDLE CAP MUST BE INSTALLED SO THAT THERE IS AN EVEN GAP BETWEEN THE SADDLE CAP AND THE BASE OF THE SADDLE LEGS AS SHOWN IN FIGURE 8-20. IF EACH SADDLE CAP IS NOT INSTALLED EVENLY, THE SADDLE LEGS COULD BECOME DEFORMED, RESULTING IN BENT BOLTS OR DAMAGED SADDLES.

### NOTE

Tightening the saddle cap fasteners properly will help prevent wear of mating components, such as the beam center bushing, saddle, and saddle cap.

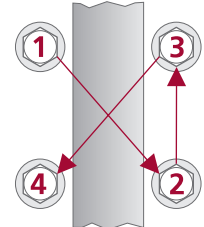
9. While tightening the saddle cap fasteners at the bolt head, maintain an even gap between the saddle and saddle cap, see Figure 8-20.

FIGURE 8-20



10. Install the saddle cap fasteners and tighten evenly in several steps and proper sequence to achieve uniform bolt tension, see Figure 8-21:
  - **46,000 • 52,000 pound capacity** –  $200 \pm 20$  foot pounds torque
  - **60,000 • 70,000 pound capacity** –  $558 \pm 32$  foot pounds torque
11. Install the tires.
12. Remove supports from the axles and lower the vehicle onto the ground.
13. Remove the wheel chocks.

FIGURE 8-21



## EQUALIZING BEAM CENTER BUSHING

### You will need

- Vertical shop press with a capacity of at least 100 tons (90 metric tones).
- Center bushing tools – Receiving Tool Part No. 66086-112, Installation Tool Part No. 66086-107 and Removal Tool Part No. 66086-110, see Special Tools section of this publication.

FIGURE 8-22

### DISASSEMBLY

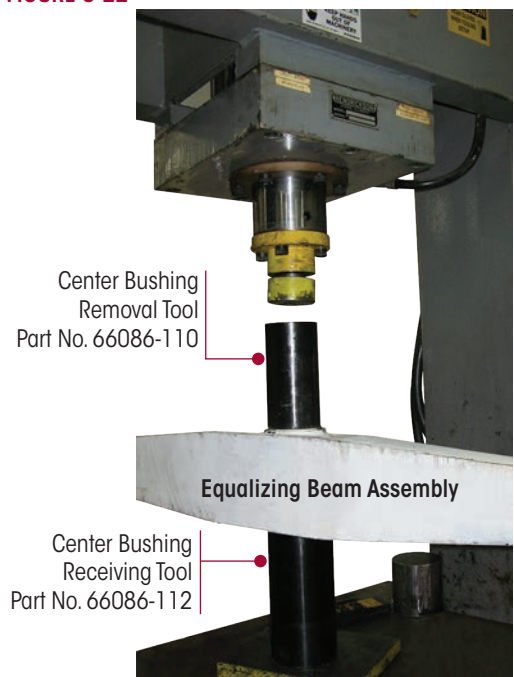
1. Remove the equalizing beam assembly from the vehicle. Follow the equalizing beam disassembly procedure in this section.



**WARNING**

DO NOT USE A CUTTING TORCH TO REMOVE ANY FASTENERS OR BUSHINGS. THE USE OF HEAT ON SUSPENSION COMPONENTS WILL ADVERSELY AFFECT THE STRENGTH OF THESE PARTS. A COMPONENT DAMAGED IN THIS MANNER CAN RESULT IN THE ADVERSE VEHICLE HANDLING AND POSSIBLE PERSONAL INJURY OR PROPERTY DAMAGE.

2. Place the equalizing beam assembly in a shop press with the center hub firmly supported on the receiving tool or on the press, see Figure 8-22.
3. Install the center bushing removal tool, ensure it is centered on the center bushing.
4. Push directly on center bushing removal tool until the center bushing is pressed out of the equalizing beam bore, see Figure 8-22.
5. Inspect the beam bore.





## INSPECTION

After removing the center bushing, thoroughly inspect the beam bore. If damaged, replace with a new equalizing beam. **DO NOT** attempt to re-bush or use an equalizing beam that has been damaged.



**FAILURE TO REPLACE AN EQUALIZING BEAM THAT HAS BEEN DAMAGED FROM BUSHING REMOVAL CAN RESULT IN THE FAILURE OF THAT BEAM, LEADING TO ADVERSE VEHICLE HANDLING AND POSSIBLE PERSONAL INJURY OR PROPERTY DAMAGE.**

When installing new center bushings the following steps will minimize the chance of damaging a new bushing:

1. Clean the bore of the equalizing beam with emery cloth or ball hone, removing any nicks or metal buildup from bushing removal.
2. Measure the inside diameter of the equalizing beam center bore. The specification for the **inside diameter** of the equalizing beam center bore on a new ULTIMAAX equalizing beam is  $3.886" \pm 0.003"$  ( $98.7 \text{ mm} \pm 0.1 \text{ mm}$ ), calculate the mean of any two measurements 90° apart in the same plane, see Figure 8-23. If the mean is **NOT** within the specified range, replacement of the equalizing beam is required.

FIGURE 8-23

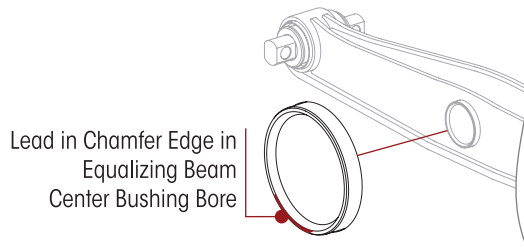


**Inside diameter** of the equalizing beam center bore on a new ULTIMAAX equalizing beam is  $3.886" \pm 0.003"$  ( $98.7 \text{ mm} \pm 0.1 \text{ mm}$ )

## NOTE

Always use the bushing outer metal for pressing operations. Pressing on the bushings inner metal may damage the bushing and require bushing replacement.

FIGURE 8-24



## ASSEMBLY

1. The equalizing beam bore may have a more substantial lead in chamfer at one end of the bore than the other, see Figure 8-24. Take advantage of the larger chamfer by pressing in the new bushing from this end.
2. Place the equalizing beam in a shop press on the receiving tool or press. Support the beam squarely at the center bore area to avoid distortion of the beam bore or bending of the beam.
3. Lubricate the equalizing beam bore and the equalizing beam center bushing outer metal sleeve with an NLGI#2 – EP (Extreme Pressure) grease, see Figure 8-25.

FIGURE 8-25



## NOTE

The ULTIMAAX center bushing has voids that must be positioned horizontally front and back, see Figure 8-26.

## NOTE

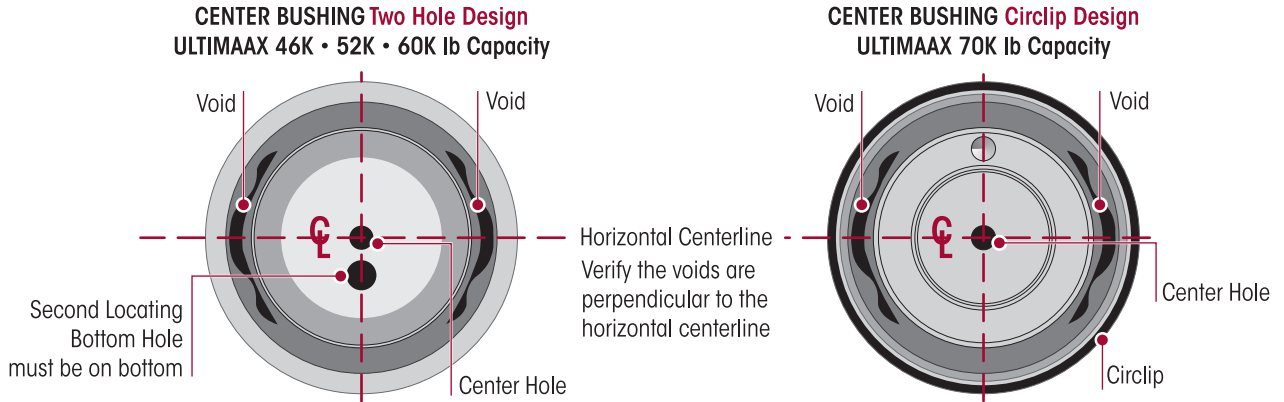
The center bushing must be square with the equalizing beam hub before pressing the center bushing into the beam. Center bushings pressed in at an angle will damage the center bushing and the equalizing beam, see Figure 8-27.



**ALWAYS USE THE CENTER BUSHING OUTER METAL FOR PRESSING OPERATIONS. PRESSING ON THE CENTER BUSHING'S INNER METAL WILL CAUSE DAMAGE TO THE CENTER BUSHING AND REQUIRE CENTER BUSHING REPLACEMENT.**

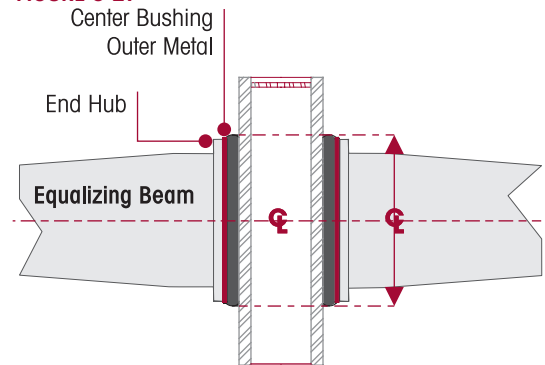


FIGURE 8-26



4. Install the center bushing installation tool, Part no. 66086-107, making sure the voids are positioned horizontally front and back and press in the new center bushing until the outer metal sleeve is centered in the equalizing beam bore, see Figures 8-26 and 8-29.
5. Wipe off excess grease from around the installed center bushing.
6. Install the equalizing beam assembly to the vehicle. Follow the equalizing beam installation procedure in this section.

FIGURE 8-27



Press the center bushing until the center bushing outer metal sleeve is centered in the end hub.

FIGURE 8-28

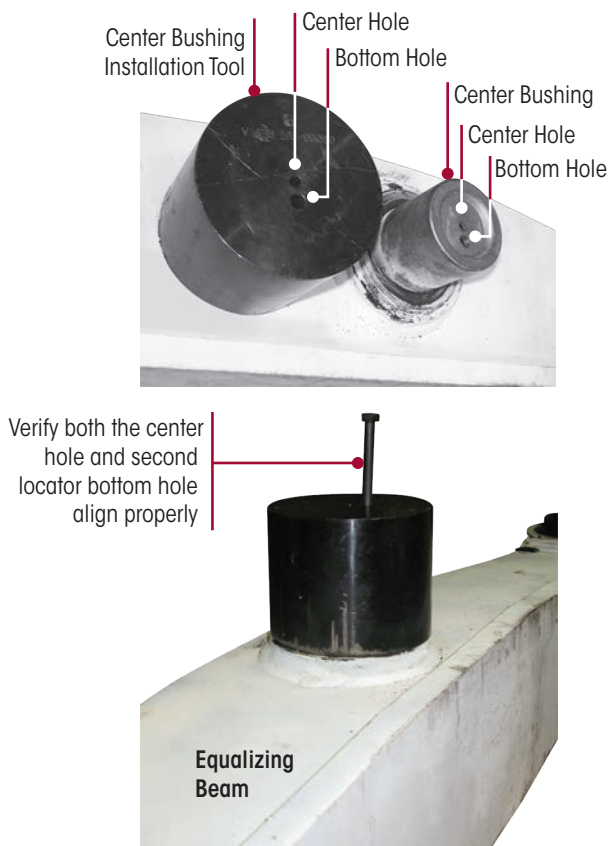
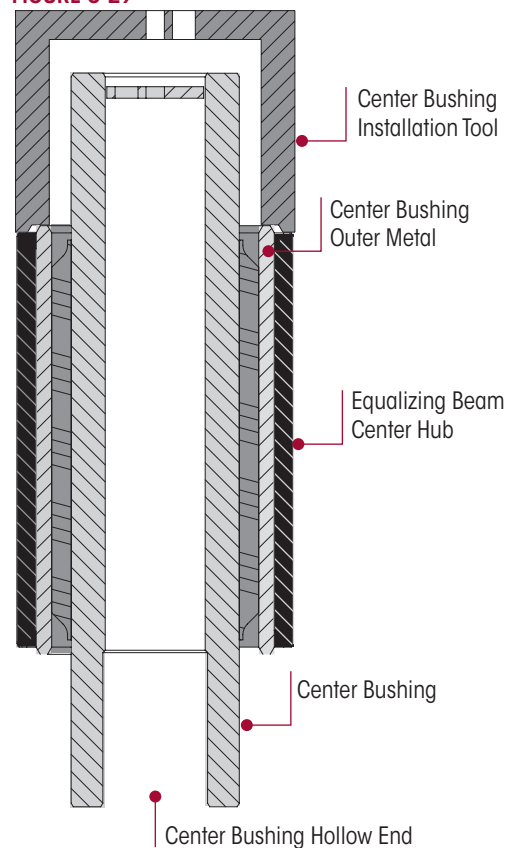


FIGURE 8-29



## BAR PIN STYLE END BUSHINGS – ULTIMAAX 46,000 • 52,000 Pound Capacity

### You will need:

- A shop press with a capacity of at least 100 tons
- End bushing service kit, refer to the Parts List section of this publication
- End bushing tools – Receiving Tool Part No. 66086-111, Installation Tool Part No. 66086-106 and Removal Tool Part No. 66086-109, see Special Tools section of this publication

### DISASSEMBLY



**WARNING**

WHEN REMOVING AND INSTALLING BUSHINGS IN THE EQUALIZING BEAMS, FOLLOW THE PROCEDURES OUTLINED IN THIS PUBLICATION. DO NOT USE A CUTTING TORCH TO REMOVE THE BUSHING OUTER METALS PRESSED IN THE BEAM BORES OR FASTENERS. WELDING, TORCHING OR ATTACHING MATERIAL TO THE EQUALIZING BEAM MUST NEVER BE PERFORMED. THE USE OF HEAT CAN ADVERSELY AFFECT THE STRENGTH OF THE EQUALIZING BEAMS AND CAN CAUSE DAMAGE TO THE EQUALIZING BEAM ASSEMBLY, ADVERSE VEHICLE HANDLING AND POSSIBLE PERSONAL INJURY OR PROPERTY DAMAGE.



**WARNING**

DISCARD USED FASTENERS. ALWAYS USE NEW FASTENERS TO COMPLETE A REPAIR. FAILURE TO DO SO COULD RESULT IN FAILURE OF THE PART OR MATING PARTS, ADVERSE VEHICLE HANDLING, PERSONAL INJURY, OR PROPERTY DAMAGE.

### NOTE

Hendrickson recommends the use of Grade 8 bolts, hardened washers, and Class C locknuts. Hardened washers are not necessary when flange head fasteners are used.

### NOTE

Whenever an equalizing beam is removed for repair or inspection of the equalizing beam end connection reveals movement, measure the distance between the axle bracket legs for correct width. Refer to Axle Bracket in Preventive Maintenance section of this publication for measurement location and dimensions. An axle bracket outside of the measurement range must be repaired or replaced. Consult the vehicle manufacturer for inspection, component repair and replacement instructions.

1. Remove equalizing beam assembly from vehicle as detailed in the equalizing beam disassembly instructions in this section.
2. Place the equalizing beam in the shop press with the beam end hub squarely supported on the receiving tool (Part No. 66086-111) or press bed.
3. Prior to removal, mark the orientation of the bar pin flats on the equalizing beam with a paint stick, see Figure 8-30.
4. Support the beam end hub with it centered on the receiving tool. Be sure the equalizing beam is squarely supported on the press bed for safety.
5. Press on the end bushing inner metal, see Figure 8-30, of the end bushing until the inner metal is flush with the top of the equalizing beam end hub. This will move the bushing rubber away from the outer metal of the bushing so the removal tool (Part No. 66086-109) can be installed.
6. Center the bushing removal tool directly on the bushing's outer metal and press the bushing out of the equalizing beam end hub.

**FIGURE 8-30**



Mark the location of the bar pin flats with a paint stick on the equalizing beam end hub

### INSPECTION

After removing the bar pin end bushings, thoroughly inspect the beam bores. If the equalizing beam is damaged from end bushing removal, replacement of the equalizing beam is required, replace with a new equalizing beam. **DO NOT** attempt re-bush or use an equalizing beam that has been damaged.

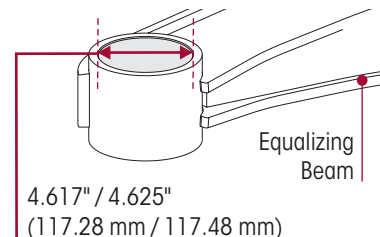


**WARNING**

FAILURE TO REPLACE AN EQUALIZING BEAM THAT HAS BEEN DAMAGED FROM BUSHING REMOVAL CAN RESULT IN THE FAILURE OF THAT BEAM, ADVERSE VEHICLE HANDLING AND POSSIBLE PERSONAL INJURY OR PROPERTY DAMAGE.

1. Clean the bores of the equalizing beams with emery cloth or ball hone, removing any nicks or metal buildup from bushing removal.
2. Measure the equalizing beam end hub bore inner diameter. The Hendrickson specification for the equalizing beam end hub bore diameter is 4.621"±0.004" (117.38 mm ± 0.10 mm), and is taken as the mean of any two readings 90° apart in the same plane, see Figure 8-31. If it is **NOT** within the specified range, replacement is required.

**FIGURE 8-31**  
Equalizing Beam  
End Hub Bore Diameter



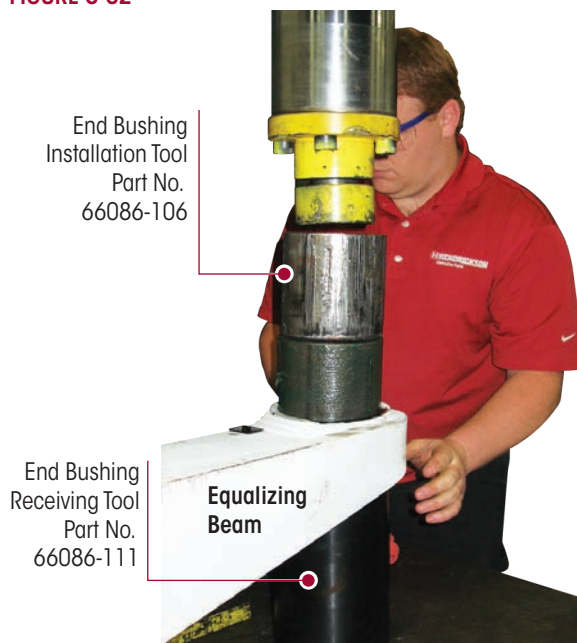
**ASSEMBLY**

**NOTE**

Always use the bushing outer metal for pressing operations. Pressing on the bushings inner metal may damage the bushing and require bushing replacement.

1. The equalizing beam bore may have a more substantial lead in chamfer at one end of the bore than the other. Take advantage of the larger chamfer by pressing in the new end bushing from this end.
2. Lubricate the equalizing beam end hub inside bore and the bar pin end bushing outer sleeve with a NLGI #2 – EP (Extreme Pressure) grease.
3. Place the equalizing beam in a shop press with the end hub, squarely supported on the receiving tool, see Figure 8-32.
4. Position and align the end bushing to the mark made before removal as shown in Figure 8-30.

**FIGURE 8-32**



**NOTE**

The end bushing must be square with the equalizing beam end hub before pressing the end bushing into the beam. End bushings pressed in at an angle will damage the end bushing and the equalizing beam.

**CAUTION**

CARE MUST BE TAKEN DURING THE INSTALLATION OF THE BUSHING. DO NOT PUSH ON THE INNER METAL OF THE BUSHING, DOING SO WILL CAUSE DAMAGE TO THE BUSHING AND VOID WARRANTY.

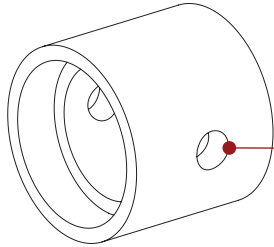
**NOTE**

Always use the bushing outer metal for pressing operations. Pressing on the bushings inner metal may damage the bushing and require bushing replacement.

5. Place the end bushing installation tool on the end hub.
6. The through hole in the tool can help align the bar pin flats due to lack of visibility. Place a bolt with enough length to go through the tool and the bar pin hole, see Figure 8-33.
7. With the tools align, press in the end bushing, see Figure 8-32
8. The end bushing must be centered within the hub of the equalizing beam, see Figure 8-34.
9. Install the equalizing beam assembly into vehicle as detailed in equalizing beam assembly in this section.



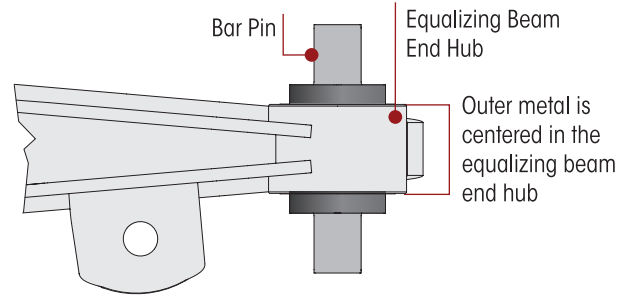
**FIGURE 8-33**



**66086-106  
End Bushing Installation Tool**

Through hole can be used to help align the bar pin flats due to lack of visibility. Place a bolt through the tool and bar pin hole.

**FIGURE 8-34**

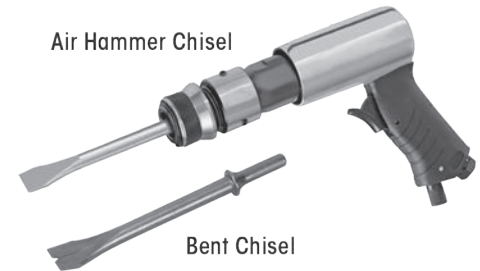


## ADAPTER STYLE END BUSHING – ULTIMAAX 60,000 • 70,000 Pound Capacity

**FIGURE 8-35**

### You will need:

- A shop press with a capacity of at least 100 tons
- Air hammer / chisel / Bent chisel, see Figure 8-35
- OTC Part No. 1763 (part no longer available, contact Hendrickson Truck Parts or Hendrickson Tech Services for available options), see Special Tools section of this publication



### DISASSEMBLY

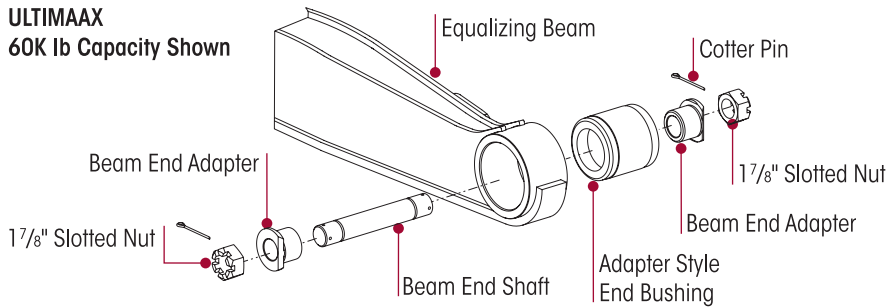
#### NOTE

It is recommended that a penetrating oil be applied to all beam end connections.

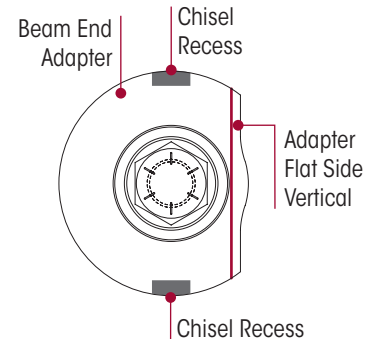
1. Remove the cotter pins, slotted nuts and end bushing adapter tube, see Figure 8-36.
2. The beam end adapters have two chisel recesses located in their flanges as shown in Figure 8-37.

**FIGURE 8-36**

**ULTIMAAX  
60K lb Capacity Shown**



**FIGURE 8-37**



3. Locate the recess for the chisel, rotate the adapter if necessary. Place the air hammer/chisel in the recess.
4. If the adapter does not turn, use a hammer to rap the outside of the axle bracket legs around the adapter area and repeat with the air hammer chisel.
5. Support the end of the equalizing beam as it may drop when the other adapter is removed.
6. Remove remaining adapters.
7. When the adapter has enough clearance between the axle bracket and the adapter flange, use a bent chisel as shown in Figure 8-35 to wedge and force the adapter out.



### WARNING

THE ADAPTER REMOVAL PROCESS CAN CAUSE DAMAGE. REUSE OF DAMAGED OR WORN ADAPTERS COULD RESULT IN A COMPONENT FAILURE LEADING TO ADVERSE VEHICLE HANDLING AND POSSIBLE PERSONAL INJURY.



**NOTE**

Due to the process necessary to remove the adapters, the adapter can be subjected to damage. **DO NOT** reuse worn or damaged adapters. Replace as necessary.

8. Remove the equalizing beam assembly from vehicle as detailed in the Equalizing Beam Disassembly instructions in this section.
9. Position the equalizing beam in the shop press and align the End Bushing Removal / Replacement Adapter with the tapered end facing the bushing to be removed, see Figure 8-38.

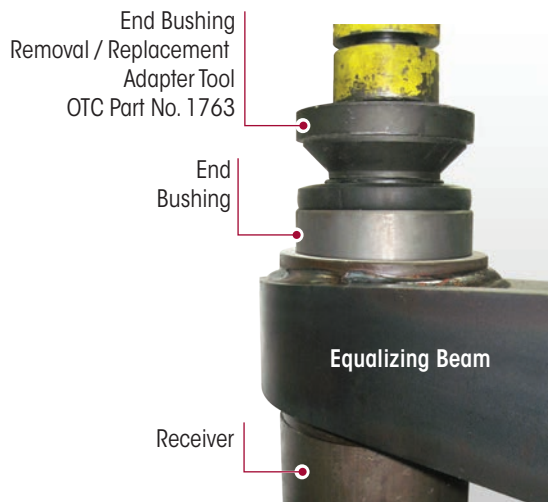


**CHECK TO INSURE PROPER ALIGNMENT OF TOOLING ADAPTERS WITH EQUALIZING BEAM COMPONENTS BEFORE APPLYING FULL HYDRAULIC PRESSURE WITH A SHOP PRESS.**

10. Apply hydraulic force and push out the old bushing.

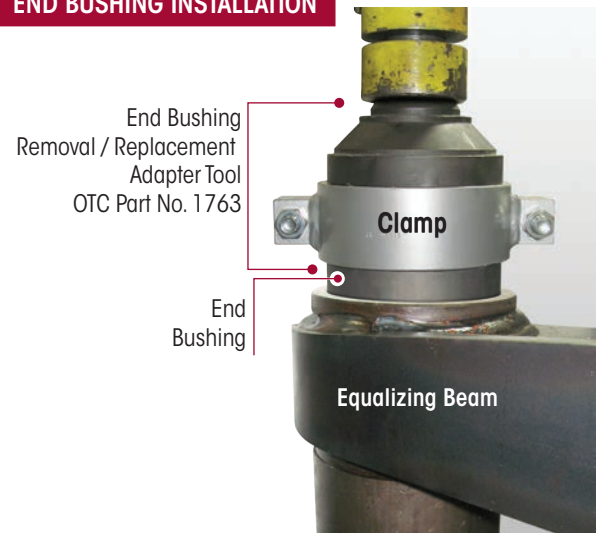
**FIGURE 8-38**

**END BUSHING REMOVAL**



**FIGURE 8-39**

**END BUSHING INSTALLATION**

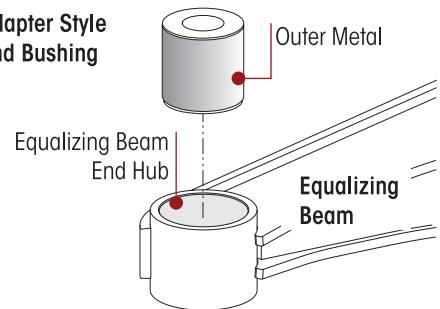


**ASSEMBLY**

1. Clean the end bushing bore with a cylinder ball hone or emery paper. Clean any debris.
2. Lubricate the equalizing beam bore and the equalizing beam center bushing outer metal sleeve with an NLGI#2 – EP (Extreme Pressure) grease, see Figure 8-40.
3. Position the end bushing removal / replacement adapter, with the tapered end facing away from the new bushing, onto the clamp, see Figure 8-39.
4. Wrench tighten the clamp onto the bushing and the adapter as shown in Figure 8-39.

**FIGURE 8-40**

**Adapter Style End Bushing**



**NOTE**

Lubricate the inside diameter of **END HUB** and the end bushing **OUTER METAL** with NLGI#2-EP (Extreme Pressure) lithium base grease

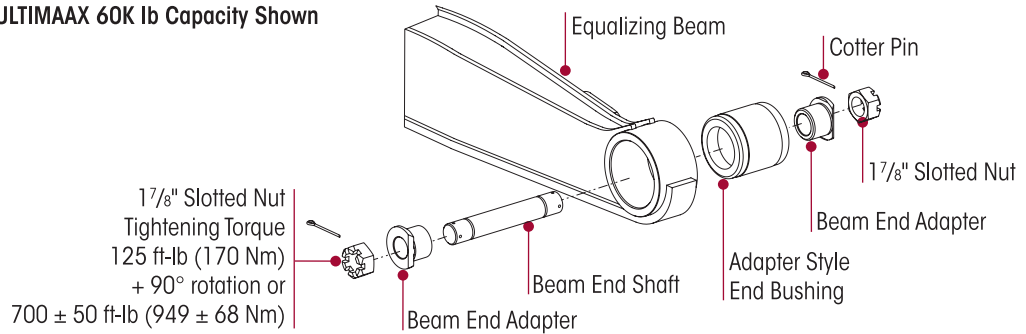


**ENSURE PROPER ALIGNMENT OF TOOLING ADAPTERS WITH EQUALIZING BEAM COMPONENTS BEFORE APPLYING FULL HYDRAULIC PRESSURE WITH A SHOP PRESS.**

5. Apply hydraulic force and press the new bushing into place. The bushing will be completely seated when the clamp makes contact with the beam face.
6. Install one adapter through the axle bracket leg at the wheel side, into the beam end bushing, see Figure 8-41.
7. Install the other adapter through the axle bracket leg at the axle side, taking advantage of the cut-off flange on the adapter to clear the axle.



**FIGURE 8-41**  
ULTIMAAX 60K lb Capacity Shown



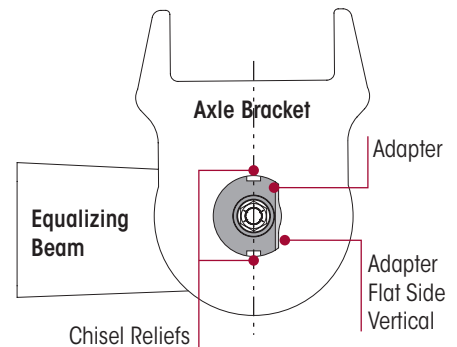
8. Insert adapter connections, see Figure 8-42.
9. Rotate the adapters so the adapter cut off flats are vertical as shown in Figure 8-42.

**NOTE**

Axes must be in operational position before fasteners are tightened to prevent pre-loading of the rubber bushing.

10. Assemble one slotted nut to the shaft and install the cotter pin. Place a suitable wrench on the nut and ensure the wrench is locked in place (braced), as shown in Figure 8-44, to prevent movement. Tighten using one of the following torque procedure.

**FIGURE 8-42**



**TORQUE PROCEDURE**



IF THE RECOMMENDED TORQUE VALUE IS NOT PROPERLY MAINTAINED, THE METAL SURFACES OF THE AXLE BRACKET LEGS, HOLES, ADAPTERS AND RUBBER BUSHING INNER METALS CAN EXPERIENCE EXCESSIVE WEAR AND/OR FAILURE. THIS CAN CAUSE SEPARATION OF COMPONENTS AND ADVERSE VEHICLE HANDLING, PROPERTY DAMAGE OR PERSONAL INJURY.

A simple torque wrench will not be sufficient to obtain the proper torque requirement. The proper torque requirement can be obtained with the use of a torque multiplier. If one is not available the use of a slug wrench is recommended.

**METHOD A: TORQUE MULTIPLIER**

**You will need:**

- Torque Multiplier
  - a. Assemble the opposite nut and use a torque wrench with multiplier.
  - b. Tighten the nut to torque multiplier value 700 ± 50 foot pounds torque, see Table 8-1.



DO NOT BACK OFF NUT TO INSTALL COTTER PIN, DOING SO MAY REDUCE THE TIGHTENING TORQUE BELOW THE REQUIRED SPECIFICATION.

- c. Install cotter pin. The nut may be advanced to the next nut slot. **DO NOT** back off nut.

**METHOD B: SLUG WRENCH**

**You will need:**

- Two slug wrenches (see Figure 8-43), 4 pound hammer
  - a. Assemble the opposite nut and using a torque wrench, tighten the nut to the initial torque value shown in Table 8-1.
  - b. Remove torque wrench and replace with the Slug Wrench. Using a four pound hammer, tighten the assembly by hitting the slug wrench near the handle as shown in Figure 8-44 until the nut has been turned to the degrees specified in Table 8-1.



TABLE 8-1

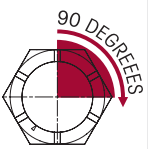
TORQUE SPECIFICATIONS			TORQUE MULTIPLIER
SLUG WRENCH METHOD			
125 Foot Pounds		¼ or 90° turn on castle nut	700 ± 50 Foot Pounds

FIGURE 8-43

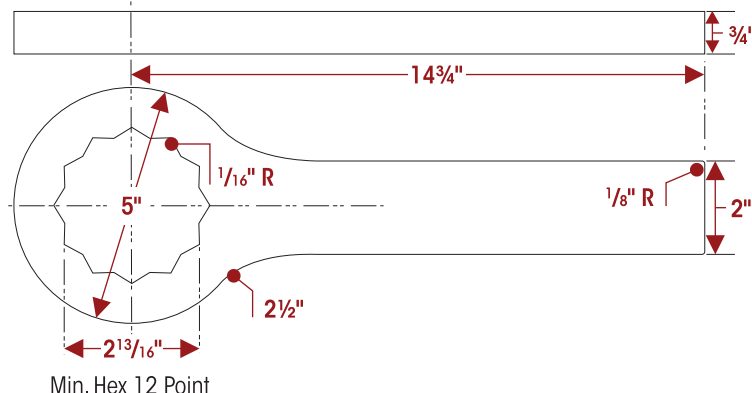
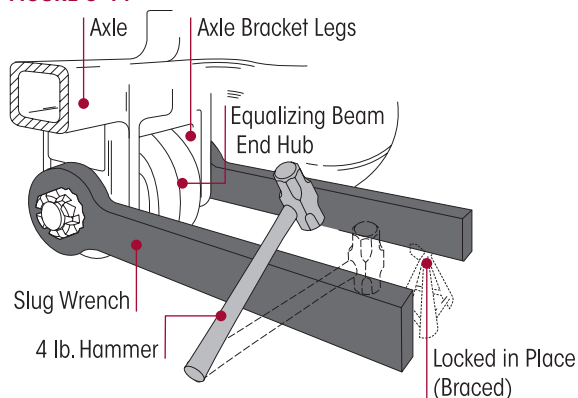


FIGURE 8-44



**CAUTION**

DO NOT BACK OFF NUT TO INSTALL COTTER PIN, DOING SO MAY REDUCE THE TIGHTENING TORQUE BELOW THE REQUIRED SPECIFICATION.

**CAUTION**

REPEATED HAMMERING BEYOND THE DEGREE SPECIFIED CAN CAUSE COMPONENT DAMAGE.

- c. Install cotter pin. The nut may be advanced to the next nut slot, **DO NOT** back off nut.

**WARNING**

INSUFFICIENT TIGHTENING TORQUES CAN CAUSE PREMATURE WEAR AND DAMAGE TO THE AXLE BRACKET LEGS, HOLES AND/OR BEAM END CONNECTION COMPONENTS, THIS CAN FURTHER CAUSE FAILURE AND SEPARATION OF COMPONENTS, AND RESULT IN ADVERSE VEHICLE HANDLING, SEVERE PERSONAL INJURY OR DEATH. MAINTAIN PROPER TIGHTENING TORQUES AT ALL TIMES.

### CROSS TUBE

A cross tube seldom requires replacement, usually only when it has been bent, possibly due to hitting an object. A bent cross tube may cause misalignment of the axles, and must be replaced immediately to eliminate abnormal tire wear.

#### METHOD A: EQUALIZING BEAM REMOVAL

Follow the steps in the Equalizing Beam Component Replacement procedure in this section. Within the procedure, after removal of the equalizing beams when the equalizing beams are separated, remove and replace cross tube.

#### METHOD B: CENTER BUSHING END PLUG REMOVAL

You will need:

- Cross Tube Service Kit 60961-759 for 46,000-60,000 pound or 60961-875 for 70,000 pound, (see Parts Lists section of this publication)
- Cutting Torch
- Welding Equipment and Hole Saw (needed for 46,000-60,000 pound capacity suspensions)

#### DISASSEMBLY

1. Use a work bay with a level surface.
2. Chock the front steer axle wheels.

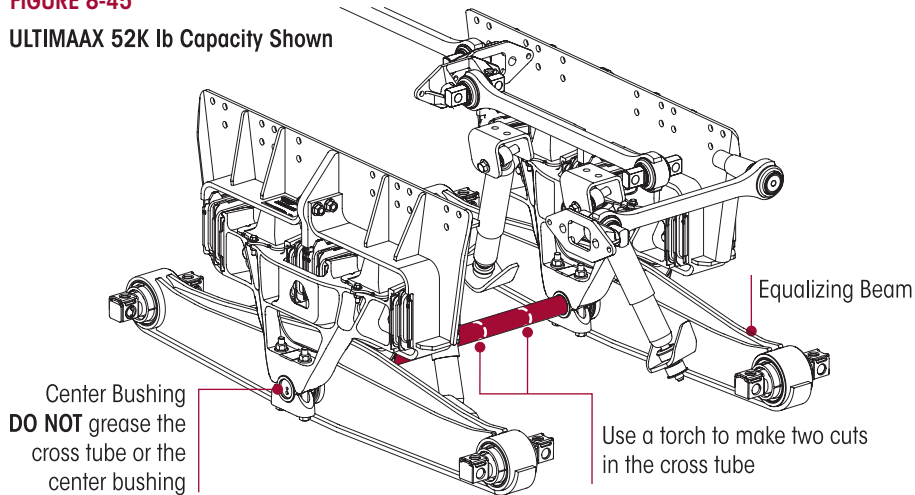


FOLLOW THE SAFETY GUIDELINES FOR OPERATING THE TORCH. USE CAUTION AS PARTS MAY BE HOT.

3. Use a cutting torch to make two cuts in the cross tube, see Figure 8-45.

**FIGURE 8-45**

ULTIMAAX 52K lb Capacity Shown

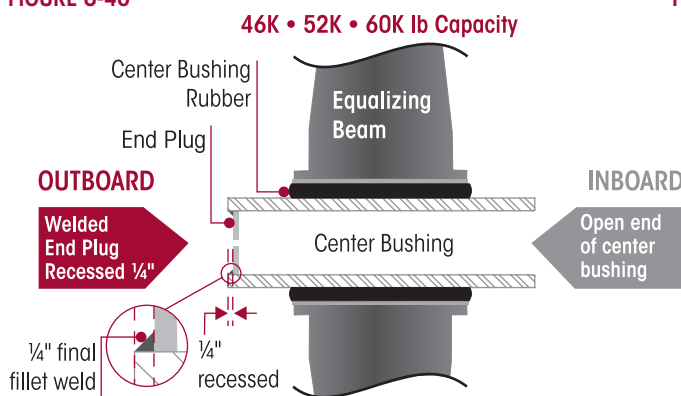


4. Remove the cut section of the cross tube and slide the remaining sections out of the center bushings and discard.

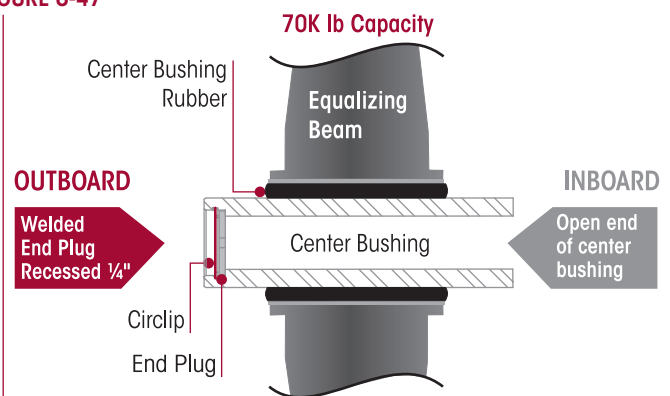
5. Remove only one center bushing end plug from the suspension using a 2" (50.8 mm) hole saw.

- **46,000 • 52,000 • 60,000 pound capacity** – Use a 2" (50.8 mm) hole saw, see Figure 8-46
- **70,000 pound capacity** – Remove circlip, see Figure 8-47

**FIGURE 8-46**



**FIGURE 8-47**



## ASSEMBLY

1. Clean the open end of the center bushing bore to approximately 1" (25.4 mm) depth of weld and debris.
2. From the open center bushing slide the new cross tube into both center bushings.
3. It may be necessary to use a floor jack under one or both equalizing beams to align the cross tube.
4. Once the new cross tube has been inserted,
  - **46,000 • 52,000 • 60,000 pound capacity** – Position the end plug 1/4" (6.6 mm) recessed in the center bushings and tack weld, see Figure 8-46. Check end plug position, final weld shall be a 1/4" (6.6 mm) fillet.
  - **70,000 pound capacity** – install new end plug and circlip, see Figure 8-47.

**WARNING****TORQUE RODS**

THIS HENDRICKSON SUSPENSION REQUIRES TORQUE RODS FOR SUSPENSION PERFORMANCE AND VEHICLE STABILITY. IF THESE TORQUE RODS ARE DISCONNECTED OR ARE NON-FUNCTIONAL, DO NOT OPERATE THE VEHICLE. OPERATING A VEHICLE WITH DISCONNECTED OR NON-FUNCTIONAL TORQUE RODS CAN RESULT IN ADVERSE VEHICLE HANDLING, COMPONENT DAMAGE, SUSPENSION/VEHICLE DAMAGE, AND/OR SEVERE PERSONAL INJURY.

**■ Longitudinal Torque Rods****NOTE**

Longitudinal TRAAX ROD® rod assemblies equipped on ULTIMAAX suspensions are non-rebushable. The entire torque rod assembly must be replaced. This feature provides superior bushing retention in the torque rod end hub.

**DISASSEMBLY**

1. Chock the front wheels of the vehicle.

**SERVICE HINT**

To remove all the load from the longitudinal torque rod, raise or lower the pinion as needed. This will ease the removal of the longitudinal torque rod.

2. Support the pinion on the axle being serviced.

**NOTE**

Prior to disassembly of the longitudinal torque rod, note the quantity and orientation of the longitudinal torque rod shims. It is required that the longitudinal torque rod shims are installed in the same orientation and location as removed to preserve the existing alignment.

3. Remove the torque rod mounting fasteners and shims (if equipped).
4. Remove the fasteners that connect the longitudinal torque rod to the cross member and axle brackets.
5. Remove longitudinal torque rod.

**ASSEMBLY**

1. Install longitudinal torque rod.
2. Install the fasteners and any shims that were removed to the cross member and axle brackets.

**NOTE**

Hendrickson recommends the use of Grade 8 bolts and Grade C locknuts. If flange head bolts and locknuts are not used then hardened structural washers must be used under bolt heads and locknuts.

3. Tighten all fasteners to vehicle manufacturer's torque specifications.
4. Verify proper pinion angle, and correct with drop in shims between the torque rod bar pin and the cross member or axle bracket depending on the direction of adjustment needed. Contact the vehicle manufacturer for proper pinion angle specifications.
5. Remove wheel chocks.

**■ Transverse Torque Rods****NOTE**

Transverse TRAAX ROD rod assemblies equipped on ULTIMAAX suspensions are non-rebushable. The entire torque rod assembly must be replaced. This feature provides superior bushing retention in the torque rod end hub.

**DISASSEMBLY**

1. Chock the front wheels of the vehicle.

**SERVICE HINT**

Note the quantity and location of shims removed to maintain the lateral alignment of the axle during assembly. See Alignment & Adjustments section of this publication.

2. Remove the torque rod mounting fasteners.



3. Remove the transverse torque rod.
4. Inspect the mounting surfaces for any wear or damage. Repair or replace as necessary.

### ASSEMBLY

1. Install the transverse torque rod.
2. Install the mounting fasteners and any shims that were removed.

---

**NOTE**

Hendrickson recommends the using Grade 8 bolts and Grade C locknuts for all torque rod attachments.

3. Prior to tightening, ensure that the vehicle is at the proper ride height. Tighten all fasteners to the required torque specification. Refer to original equipment manufacturer for specifications.
4. Check the lateral alignment. If not within vehicle manufacturer's specified range, a lateral alignment is necessary. See Lateral Alignment in the Alignment & Adjustments section of this publication.
5. Remove the wheel chocks.

### ■ V-rods, vehicles built prior to February 2021

### DISASSEMBLY

1. Chock the front wheels of the vehicle.
2. Remove and discard the V-rod mounting fasteners.
3. Remove the V-rod.
4. Inspect the mounting surface for any wear or damage. Repair or replace as necessary.

### ASSEMBLY

1. Install the V-rod.
2. Install the new mounting fasteners.

---

**NOTE**

Hendrickson recommends the use of Grade 8 bolts and Grade C locknuts. If flange head bolts and locknuts are not used then hardened structural washers must be used under bolt heads and locknuts.

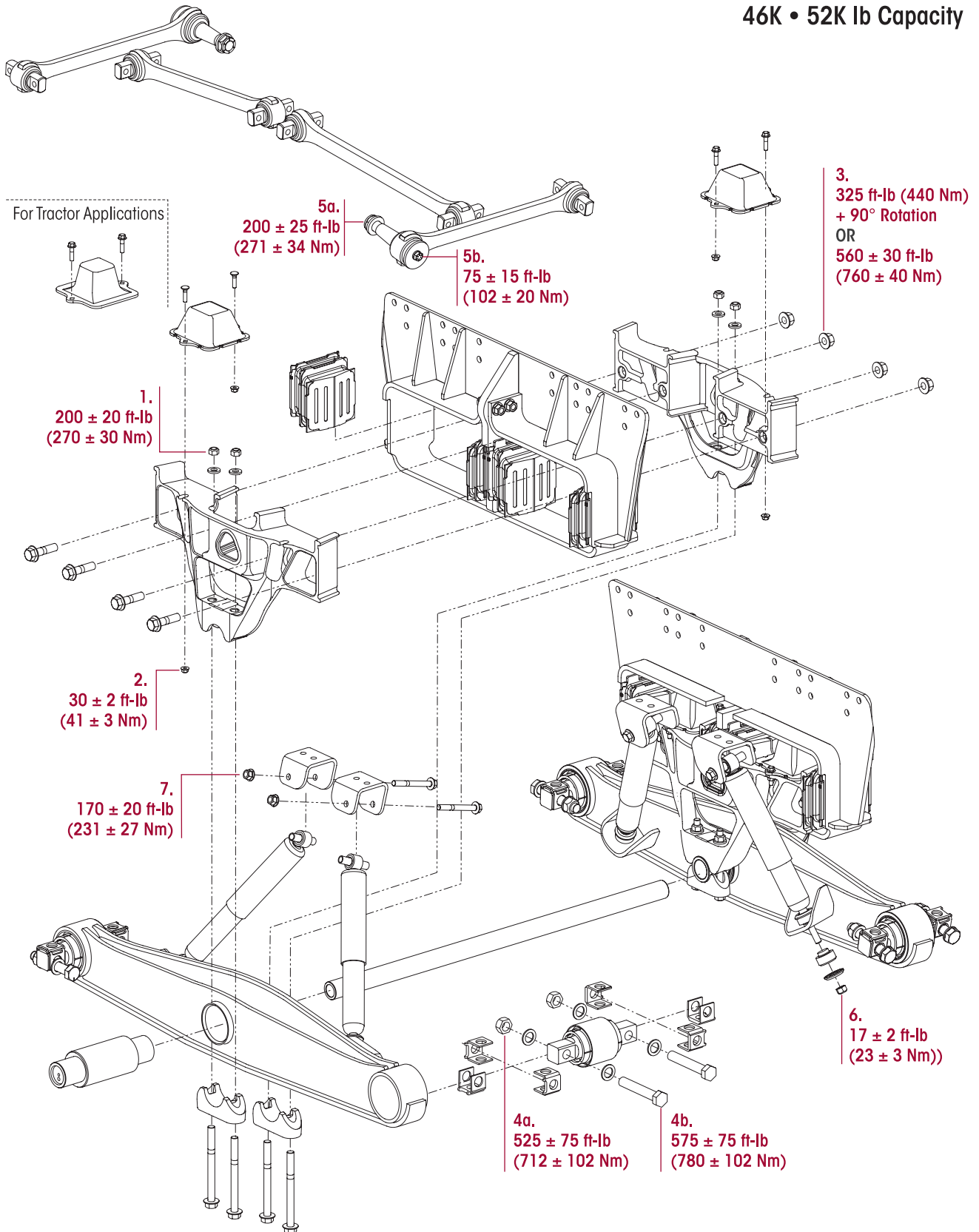
3. Prior to tightening, ensure that the vehicle is at the proper ride height. Tighten all fasteners to the required torque specification. Refer to vehicle manufacturer for specifications.
4. Remove wheel chocks.



# SECTION 9 Torque Specifications

HENDRICKSON RECOMMENDED TORQUE VALUES  
PROVIDED IN FOOT POUNDS AND IN NEWTON METERS

46K • 52K lb Capacity





ULTIMAAX 46,000 • 52,000 pound for Kenworth Vehicles

HENDRICKSON RECOMMENDED TORQUE SPECIFICATIONS

NO.	COMPONENT	FASTENER		TORQUE VALUE		
		*Quantity	Size	Foot Pounds	Newton Meters	
1	Saddle Assembly to Center Bushing Locknut	8	M16	200 ± 20	270 ± 30	
2	Saddle Assembly to Progressive Load Spring Flange Locknut	8	M10	30 ± 2	41 ± 3	
3	Saddle Assembly Halves Flange Locknuts	8	M20	325 + 90° rotation or 560 ± 30	440 + 90° rotation or 760 ± 40	
4a	Bar Pin End Bushing	at the Locknut	8	1"-8 UNC	525 ± 75	712 ± 102
4b		at the Bolt Head	8	1"-8 UNC	575 ± 75	780 ± 102
5a	Transverse Torque Rod to Axle	at the Locknut	2	1¼"-12 UNF	200 ± 25	271 ± 34
5b		at the Bolt Head	2	5/8"-11 UNC	75 ± 15	102 ± 20
6	Shock Absorber to Lower Bracket	4	5/8"-18 UNF	17 ± 2	23 ± 3	
7	Shock Absorber to Upper Shock Bracket	4	M16	170 ± 20	231 ± 27	

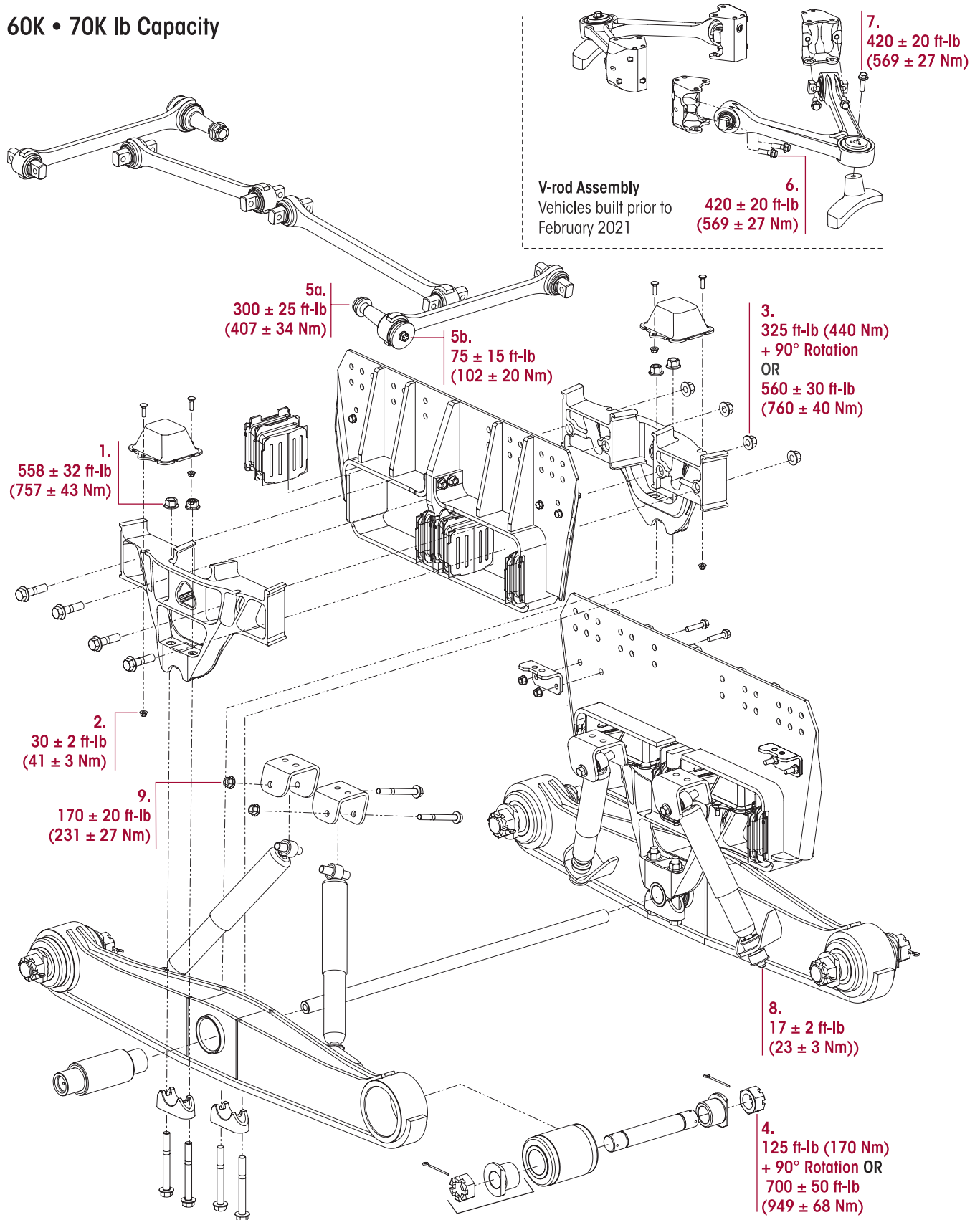
**NOTE:** \* Quantities shown are per suspension.

\*\* Torque values shown in this publication apply only if Hendrickson supplied fasteners are used. If non Hendrickson fasteners are used, follow the torque specification listed in the vehicle manufacturer's service manual.



HENDRICKSON RECOMMENDED TORQUE VALUES  
PROVIDED IN FOOT POUNDS AND IN NEWTON METERS

60K • 70K lb Capacity





ULTIMAAX 60,000 • 70,000 pound for Kenworth / Peterbilt Vehicles

HENDRICKSON RECOMMENDED TORQUE SPECIFICATIONS

NO.	COMPONENT	FASTENER		TORQUE VALUE		
		*Quantity	Size	Foot Pounds	Newton Meters	
1	Saddle Assembly to Center Bushing Locknut	8	M20	558 ± 32	757 ± 43	
2	Saddle Assembly to Progressive Load Spring Flange Locknut	8	M10	30 ± 2	41 ± 3	
3	Saddle Assembly Halves Flange Locknuts	8	M20	325 + 90° rotation or 560 ± 30	440 + 90° rotation or 760 ± 40	
4	Adapter Style End Bushing	8	1 7/8"	125 + 90° rotation or 700 ± 50	170 + 90° rotation or 949 ± 68	
5a	Transverse Torque Rod to Axle	at the Locknut	2	1 3/4"-12 UNF	300 ± 25	407 ± 34
5b		at the Bolt Head	2	5/8"-11 UNC	75 ± 15	102 ± 20
6	V-rod to Corner Bracket	8	M20	420 ± 20	569 ± 27	
7	V-rod to Axle Apex Bracket	2	M20	420 ± 20	569 ± 27	
8	Shock Absorber to Lower Bracket	4	5/8"-18 UNF	17 ± 2	23 ± 3	
9	Shock Absorber to Upper Shock Bracket	4	M16	170 ± 20	231 ± 27	

**NOTE:** \* Quantities shown are per suspension.  
 \*\* Torque values shown in this publication apply only if Hendrickson supplied fasteners are used. If non Hendrickson fasteners are used, follow the torque specification listed in the vehicle manufacturer's service manual.



## SECTION 10 Troubleshooting Guide

### ULTIMAAX for Kenworth / Peterbilt Vehicles

TROUBLESHOOTING GUIDE		
CONDITION	POSSIBLE CAUSE	CORRECTION
Suspension has harsh or bumpy ride	Damaged shock absorber	Replace shock absorbers
	Damaged progressive load spring	Replace progressive load springs, must be replaced in pairs
	Damaged shear spring	Replace shear spring
	Vehicle overloaded	Redistribute or reduce load to correct weight
Vehicle leans	Damaged progressive load spring	Replace progressive load springs, must be replaced in pairs
	Damaged shear spring	Replace shear spring
	Bent cross tube	Replace cross tube
	Weight bias	Redistribute load to correct weight bias
Irregular tire wear	Incorrect axle alignment	Axle alignment is permanently set at the time of vehicle manufacture. Contact vehicle manufacturer.
	Bent cross tube	Replace cross tube
	Damaged, bent, cracked suspension component	Replace damaged component
Loose or missing suspension fasteners	Suspension is overloaded	Reduce and/or redistribute load to correct weight
		Replace and/or properly tighten fasteners to the proper torque specification
	Improper torque or over torque	Increase inspection interval of fasteners
		Replace and/or properly tighten fasteners to the proper torque specification
Frame hanger cracked	Suspension is overloaded	Replace frame hanger assembly
		Reduce and/or redistribute load to correct weight
	Loose or missing suspension fasteners	Replace frame hanger assembly
		Increase inspection interval of fasteners
		Replace fasteners and/or properly tighten fasteners to the proper torque specification
Damaged frame hanger assembly	Replace frame hanger assembly	
Saddle leg to equalizing beam contact	Damaged, bent, worn, or cracked suspension component(s)	Replace damaged component
	Cross tube bent or missing	Replace cross tube
	Loose or worn saddle hex bolts	Replace saddle hex bolts, inspect mating components
	Saddles not center on equalizing beam	Center saddles on the equalizing beam
	Saddles not center on center bushing	Replace center bushing



Actual product performance may vary depending upon vehicle configuration, operation, service and other factors.  
All applications must comply with applicable Hendrickson specifications and must be approved by the respective vehicle manufacturer with the vehicle in its original, as-built configuration.  
Contact Hendrickson for additional details regarding specifications, applications, capacities, and operation, service and maintenance instructions.

*Call Hendrickson at **630.910.2800** or **855.RIDERED (855.743.3733)** for additional information.*



[www.hendrickson-intl.com](http://www.hendrickson-intl.com)

**TRUCK COMMERCIAL VEHICLE SYSTEMS**  
800 South Frontage Road  
Woodridge, IL 60517-4904 USA  
855.743.3733 (Toll-free U.S. and Canada)  
630.910.2800 (Outside U.S. and Canada)  
Fax 630.910.2899

17730-301 Rev E 04-26

© 2016 – 2026 Hendrickson USA, L.L.C. All Rights Reserved. All trademarks shown are owned by Hendrickson USA, L.L.C., or one of the affiliates, in one or more countries.  
Information contained in this literature was accurate at the time of publication. Product changes may have been made after the copyright date that are not reflected.

Printed in United States of America