

HVANTRAAX®

HKANT 23K/40K/46K/69K23/ HKAT 50K/69K25/HKANL 23K/ and HKARL 46K Specifications

LIT NO: L629

DATE: February 2024

REVISION: N

HKANL 23K

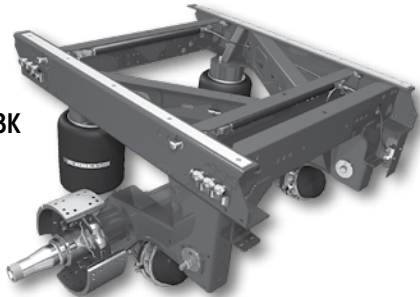

HKANT 23K

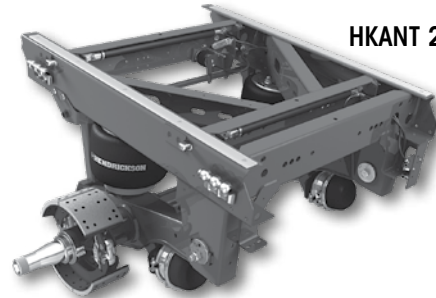

HKARL 46K

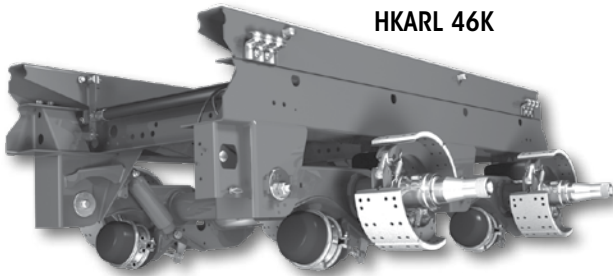

HKAT 50K



HKANT 69K23

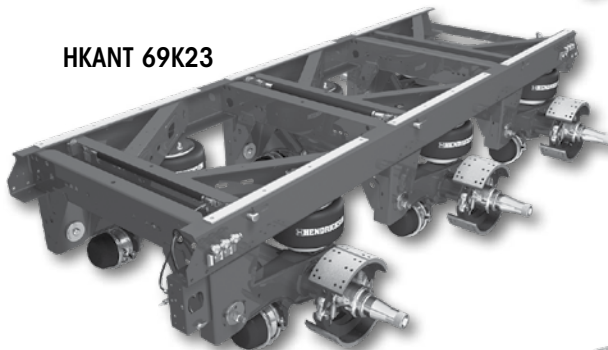

HKANT 40K and 46K

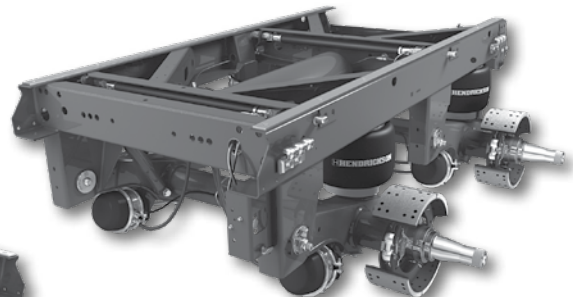

HKAT 69K25

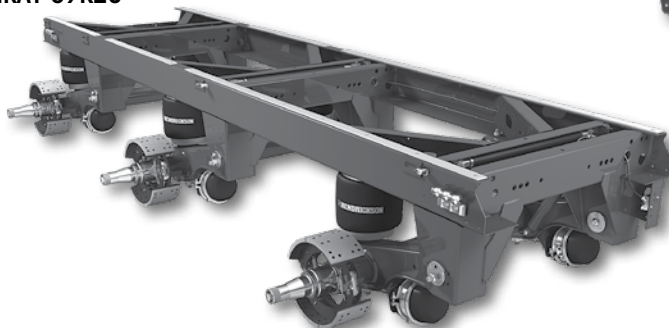



TABLE OF CONTENTS

SPECIFICATIONS

HKANL 23K 3
HKANT 23K 4
HKANT 40K 5
HKANT 46K 6
HKANT 46K - 121 Spread 7
HKAT 50K 8
HKANT 69K23 9
HKAT 69K25 10
HKARL 46K 11

OPTIONS 12



HKANL 23K

SYSTEM CAPACITY*	23,000 lbs. (10 400 kg)
APPLICATION	On-highway or maintained roads; not available in "high control" for single-axle, multi-trailer applications
TRAILER TYPES^{1,2}	U.S.A. and Canada: Dry, refrigerated and specialty van Mexico, Central and South America: None
AXLE DATA	Diameter: 5.75-inch LDA™ Large-Diameter Axle Arrangement: Single Track: 71.5- and 77.5-inch Spread: N/A
FRAME TYPES	Steel only: 96- and 102-inch wide trailers (42- and 48-inch wide slider boxes)
BASE MODEL DESCRIPTION	VANTRAAX® HKANL 23K slider suspension system consisting of 48-inch wide slider box with 16- or 17-inch ride height suspension, 77.5-inch axle track, HN spindles, 16.5- x 7-inch brakes with H2O brake lining, ABS brackets, QUIK-ALIGN® pivot connection, QUIK-DRAW® pin-pull mechanism and standard Cam Tube System™.



* System capacity refers to the suspension, axle and slider. Ratings for brakes and wheel-end components differ depending upon options chosen.

1. Review tire clearance. Wheel cut outs may be necessary.
2. Trailer body rails must be able to support the lifted VANTRAAX System.

AXLE SPREAD (inches)	RIDE HEIGHT (inches)	SYSTEM HEIGHT (inches)	FRONT AXLE LOCATION (inches)	JOUNCE (inches)	REBOUND (inches)	WEIGHT (pounds)
N/A	16	24.25	28.1	5.5	4.3	857
	17	25.25	27.9	6.5	3.3	857

Note: Weight includes 48-inch wide slider, suspension, HN LDA™ Large-Diameter Axle (5.75-inch) and foundation brake components (body rail weights not included). For a 42-inch wide slider system, deduct 21 pounds. For fixed-pin option, deduct 8 pounds. Does not include box shims.

SPECIFICATIONS

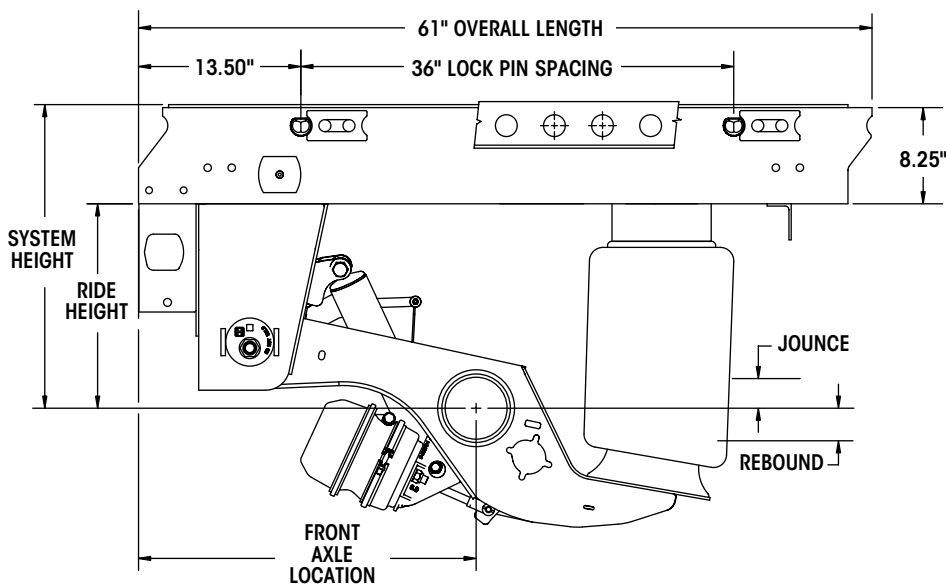



HKANT 23K

SYSTEM CAPACITY*	23,000 lbs. (10 400 kg)	
APPLICATION	On-highway or maintained roads; not available in "high control" for single-axle, multi-trailer applications	
TRAILER TYPES	U.S.A. and Canada: Dry, refrigerated and specialty van Mexico, Central and South America: None	
AXLE DATA	Diameter: 5.75-inch LDA™ Large-Diameter Axle Arrangement: Single Track: 71.5- and 77.5-inch Spread: N/A	
FRAME TYPES	Steel only: 96- and 102-inch wide trailers (42- and 48-inch wide slider boxes)	
BASE MODEL DESCRIPTION	VANTRAAX® HKANT 23K slider suspension system consisting of 48-inch wide slider box with 16-inch ride height suspension, 77.5-inch axle track, HN spindles, 16.5- x 7-inch brakes with H20 brake lining, ABS brackets, QUIK-ALIGN® pivot connection, QUIK-DRAW® pin-pull mechanism and standard Cam Tube System™.	

*System capacity refers to the suspension, axle and slider. Ratings for brakes and wheel-end components differ depending upon options chosen.

AXLE SPREAD (inches)	RIDE HEIGHT (inches)	SYSTEM HEIGHT (inches)	FRONT AXLE LOCATION (inches)	JOUNCE (inches)	REBOUND (inches)	WEIGHT (pounds)
N/A	16	24.25	28.4	2.8	4.5	785
	17	25.25	28.0	2.8	3.5	787

Note: Weight includes 48-inch wide slider, suspension, HN LDA™ Large-Diameter Axle (5.75-inch) and foundation brake components (body rail weights not included). For a 42-inch wide slider system, deduct 19 pounds. For fixed-pin option, deduct 8 pounds. Does not include box shims.

SPECIFICATIONS

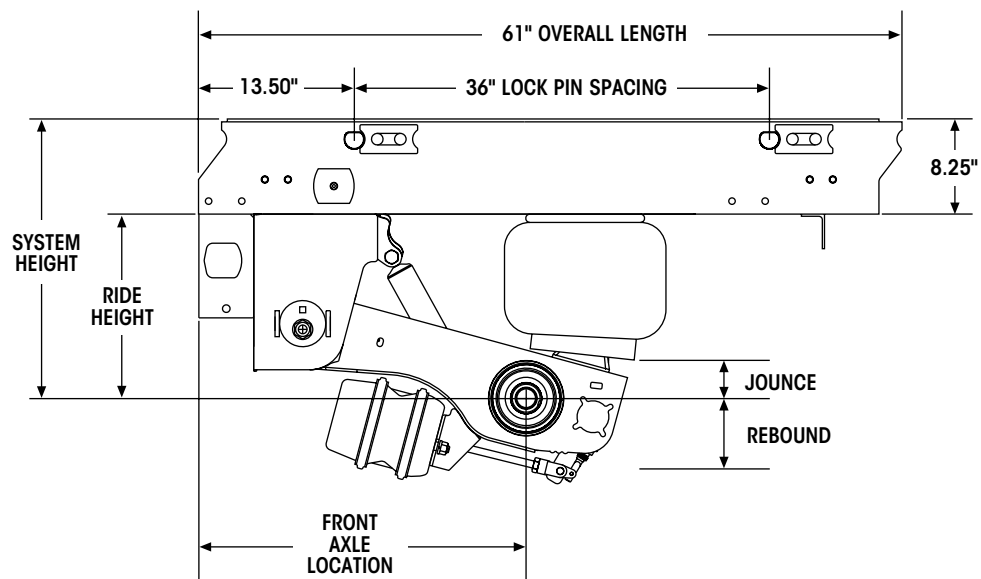



HKANT 40K

SYSTEM CAPACITY*	40,000 lbs. (18 000 kg)
APPLICATION	On-highway
TRAILER TYPES	U.S.A. and Canada: Dry and refrigerated van Mexico, Central and South America: None
AXLE DATA	Diameter: 5.75-inch LDA™ Large-Diameter Axle Arrangement: Tandem Track: 71.5- and 77.5--inch Spread: 49-inch
FRAME TYPES	Steel only: 96- and 102-inch wide trailers (42- and 48-inch wide slider boxes)
BASE MODEL DESCRIPTION	VANTRAA [®] HKANT 40K slider suspension system consisting of 49-inch spread, 48-inch wide slider box with two 16-inch ride height suspensions, 77.5-inch axle track, HN spindles, 16.5- × 7-inch brakes with H2O brake lining, ABS brackets, QUIK-ALIGN [®] pivot connection, QUIK-DRAW [®] pin-pull mechanism and standard Cam Tube System™.



*System capacity refers to the suspensions, axles and slider. Ratings for brakes and wheel-end components differ depending upon options chosen.

AXLE SPREAD (inches)	RIDE HEIGHT (inches)	SYSTEM HEIGHT (inches)	FRONT AXLE LOCATION (inches)	JOUNCE (inches)	REBOUND (inches)	WEIGHT (pounds)
49	16	24.25	28.4	2.9	4.5	1,394
	17	25.25	28.0	2.9	3.5	1,398

Note: Weight includes 48-inch wide slider, suspensions, HN LDA™ Large-Diameter Axle (5.75-inch) and foundation brake components (body rail weights not included). For a 42-inch wide slider system, deduct 33 pounds. For manual pin-pull mechanism, add 13 pounds. Does not include SURELOK[®] or box shims.

SPECIFICATIONS

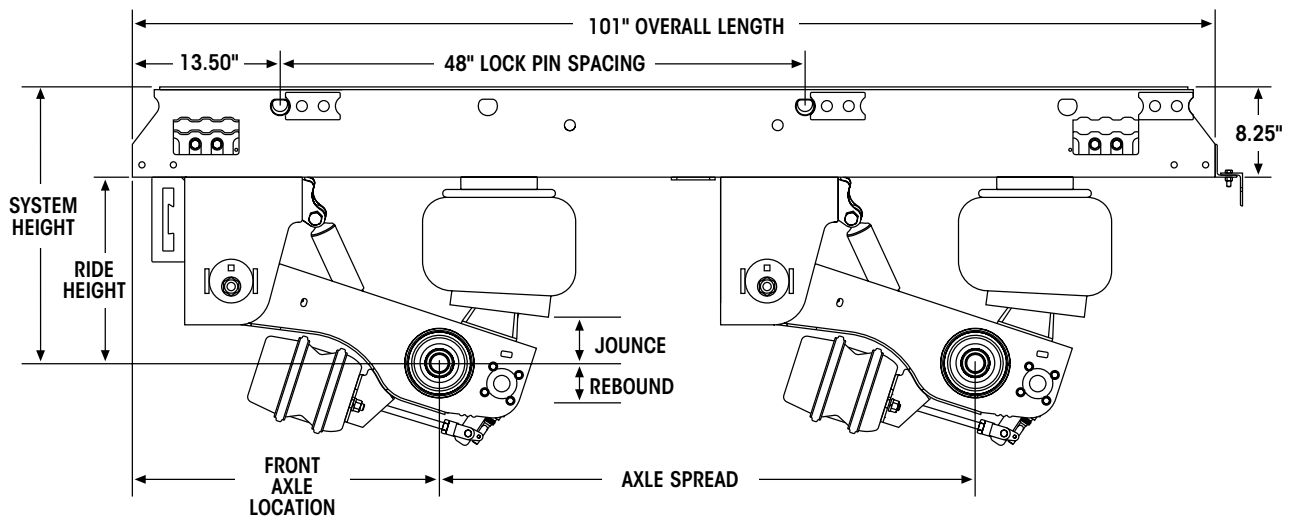



HKANT 46K

SYSTEM CAPACITY*	46,000 lbs. (20 700 kg)
APPLICATION	On-highway or maintained roads
TRAILER TYPES	U.S.A. and Canada: Dry, refrigerated and specialty van Mexico, Central and South America: None
AXLE DATA	Diameter: 5.75-inch LDA™ Large-Diameter Axle Arrangement: Tandem Track: 71.5- and 77.5-inch Spread: 49-inch
FRAME TYPES	Steel only: 96- and 102-inch wide trailers (42- and 48-inch wide slider boxes)
BASE MODEL DESCRIPTION	VANTRAA [®] HKANT 46K slider suspension system consisting of 49-inch spread, 48-inch wide slider box with two 16-inch ride height suspensions, 77.5-inch axle track, HN spindles, 16.5- × 7-inch brakes with H20 brake lining, ABS brackets, QUIK-ALIGN [®] pivot connection, QUIK-DRAW [®] pin-pull mechanism and standard Cam Tube System™.



*System capacity refers to the suspensions, axles and slider. Ratings for brakes and wheel-end components differ depending upon options chosen.

AXLE SPREAD (inches)	RISE HEIGHT (inches)	SYSTEM HEIGHT (inches)	FRONT AXLE LOCATION (inches)	JOUNCE (inches)	REBOUND (inches)	WEIGHT (pounds)
49	16	24.25	28.4	2.8	5.5	1,405
	17	25.25	28.0	2.8	4.5	1,409

Note: Weight includes 48-inch wide slider, suspensions, HN LDA™ Large-Diameter Axle (5.75-inch) and foundation brake components (body rail weights not included). For a 42-inch wide slider system, deduct 33 pounds. For manual pin-pull mechanism, add 13 pounds. Does not include SURELOK[®] or box shims.

SPECIFICATIONS

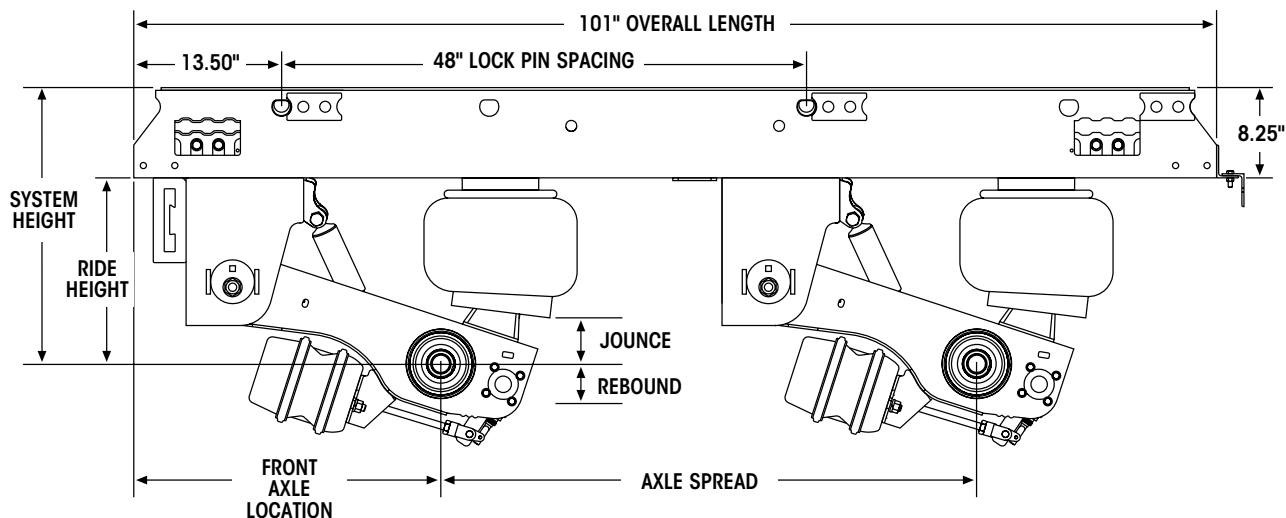



HKANT 46K — 121-inch Spread

SYSTEM CAPACITY*	46,000 lbs. (20 700 kg)
APPLICATION	On-highway or maintained roads
TRAILER TYPES	U.S.A. and Canada: Dry, refrigerated and specialty van Mexico, Central and South America: None
AXLE DATA	Diameter: 5.75-inch LDA™ Large-Diameter Axle Arrangement: Tandem Track: 77.5-inch Spread: 121-inch
FRAME TYPES	Steel only: 102-inch wide trailers (48-inch wide slider box)
BASE MODEL DESCRIPTION	VANTRAAX® HKANT 46K slider suspension system consisting of 121-inch spread, 48-inch wide slider box with two 16-inch ride height suspensions, 77.5-inch axle track, HN spindles, 16.5- x 7-inch brakes with H2O brake lining, ABS brackets, QUIK-ALIGN® pivot connection, QUIK-DRAW® pin-pull mechanism and standard Cam Tube System™.



*System capacity refers to the suspensions, axles and slider. Ratings for brakes and wheel-end components differ depending upon options chosen.

AXLE SPREAD (inches)	RISE HEIGHT (inches)	SYSTEM HEIGHT (inches)	FRONT AXLE LOCATION (inches)	JOUNCE (inches)	REBOUND (inches)	WEIGHT (pounds)
121	16	24.25	28.4	2.8	4.5	1,652
	17	25.25	28.0	2.8	3.5	1,656

Note: Weight includes 48-inch wide slider, suspensions, HN LDA™ Large-Diameter Axle (5.75-inch) and foundation brake components (body rail weights not included). For fixed-pin option, deduct 9 pounds. Does not include SURELOK® or box shims.

SPECIFICATIONS

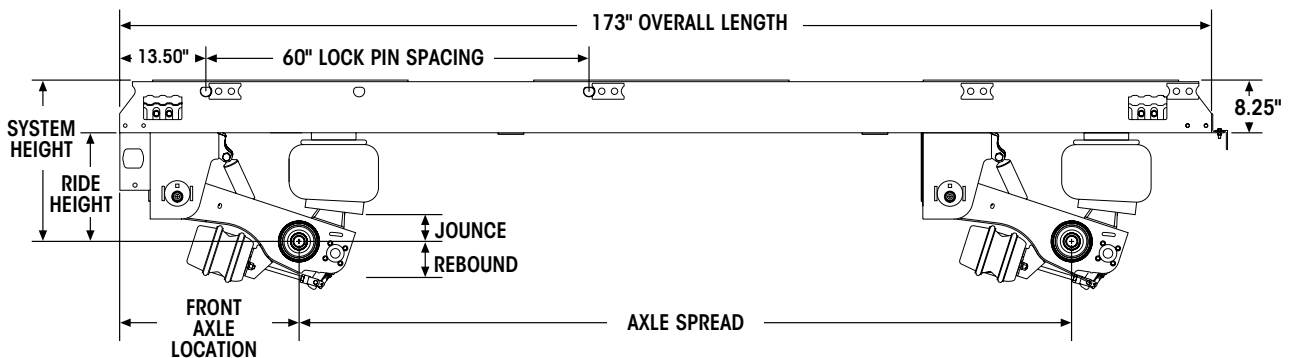



HKAT 50K

SYSTEM CAPACITY*	50,000 lbs. (22 500 kg)
APPLICATION	On-highway or maintained roads "domiciled in Mexico"
TRAILER TYPES	U.S.A. and Canada: Dry, refrigerated and specialty van Mexico, Central and South America: Dry, refrigerated and specialty van
AXLE DATA	Diameter: 5.75-inch LDA™ Large-Diameter Axle Arrangement: Tandem Track: 71.5- and 77.5-inch Spread: 49-inch
FRAME TYPES	Steel only: 96- and 102-inch wide trailers (42- and 48-inch wide slider boxes)
BASE MODEL DESCRIPTION	VANTRAA [®] HKAT 50K slider suspension system consisting of 49-inch spread, 48-inch wide slider box with two 16-inch ride height suspensions, 77.5-inch axle track, HN spindles, 16.5- × 7-inch brakes with H20 brake lining, ABS brackets, QUIK-ALIGN [®] pivot connection, QUIK-DRAW [®] pin-pull mechanism and standard Cam Tube System™.



*System capacity refers to the suspensions, axles and slider. Ratings for brakes and wheel-end components differ depending upon options chosen.

AXLE SPREAD (inches)	RISE HEIGHT (inches)	SYSTEM HEIGHT (inches)	FRONT AXLE LOCATION (inches)	JOUNCE (inches)	REBOUND (inches)	WEIGHT (pounds)
49	16	24.25	28.4	3.1	4.6	1,579
	17	25.25	28.0	3.3	3.6	1,584

Note: Weight includes 48-inch wide slider, suspensions, HN LDA™ Large-Diameter Axle (5.75-inch) and foundation brake components (body rail weights not included). For a 42-inch wide slider system, deduct 41 pounds. For manual pin-pull mechanism, add 15 pounds. For fixed-pin option, deduct 21 pounds. Does not include SURELOK[®] or box shims.

SPECIFICATIONS

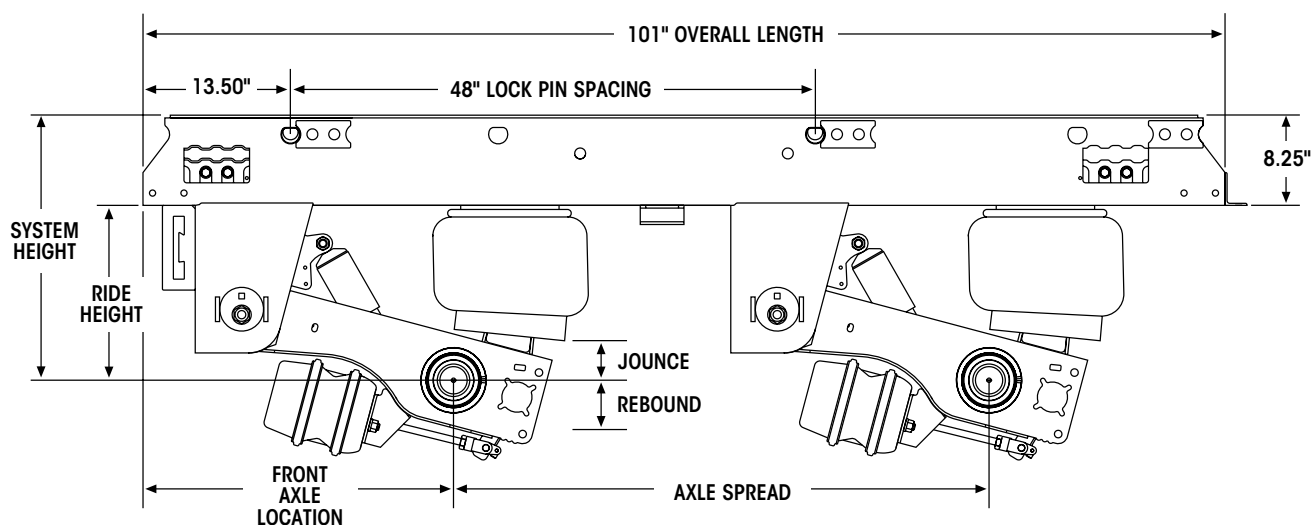



HKANT 69K23

SYSTEM CAPACITY*	69,000 lbs. (31 200 kg)
APPLICATION	On-highway or maintained roads
TRAILER TYPES	U.S.A. and Canada: Dry, refrigerated and specialty van Mexico, Central and South America: None
AXLE DATA	Diameter: 5.75-inch LDA™ Large-Diameter Axle Capacity: 23,000 lbs. (10 400 kg) Arrangement: Tridem Track: 77.5-inch Spread: 49-, 60- and 72-inch
FRAME TYPES	Steel only: 96- and 102-inch wide trailers (48-inch wide slider box)
BASE MODEL DESCRIPTION	VANTRAAX® HKANT 69K23 slider suspension system consisting of 72-inch spread, 48-inch wide slider box with three 16-inch ride height suspensions, 77.5-inch axle track, HN spindles, 16.5- x 7-inch brakes with H2O brake lining, ABS brackets, QUIK-ALIGN® pivot connection, QUIK-DRAW® pin-pull mechanism and standard Cam Tube System™.

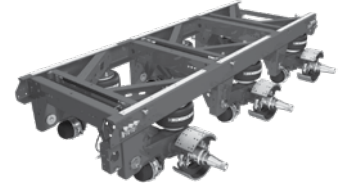

*System capacity refers to the suspensions, axles and slider. Ratings for brakes and wheel-end components differ depending upon options chosen.

AXLE SPREAD (inches)	RISE HEIGHT (inches)	SYSTEM HEIGHT (inches)	FRONT AXLE LOCATION (inches)	JOUNCE (inches)	REBOUND (inches)	WEIGHT (pounds)
60	16	24.25	28.4	2.8	4.7	2,188
	17	25.25	28.0	3.0	3.7	2,195
72	16	24.25	28.4	2.8	4.7	2,236
	17	25.25	28.0	3.0	3.7	2,242
49	16	24.25	28.4	2.8	4.7	2,143
	17	25.25	28.0	3.0	3.7	2,149

Note: Weight includes 48-inch wide slider, suspensions, HN LDA™ Large-Diameter Axle (5.75-inch) and foundation brake components (body rail weights not included). For a 42-inch wide slider system, deduct 59 pounds. For manual pin-pull mechanism, add 18 pounds for the 72-inch spread model and 14 pounds for the 60-inch spread model. For fixed-pin option, deduct 24 pounds for the 72-inch spread model and 26 pounds for the 60-inch spread model. Does not include SURELOK® or box shims.

SPECIFICATIONS

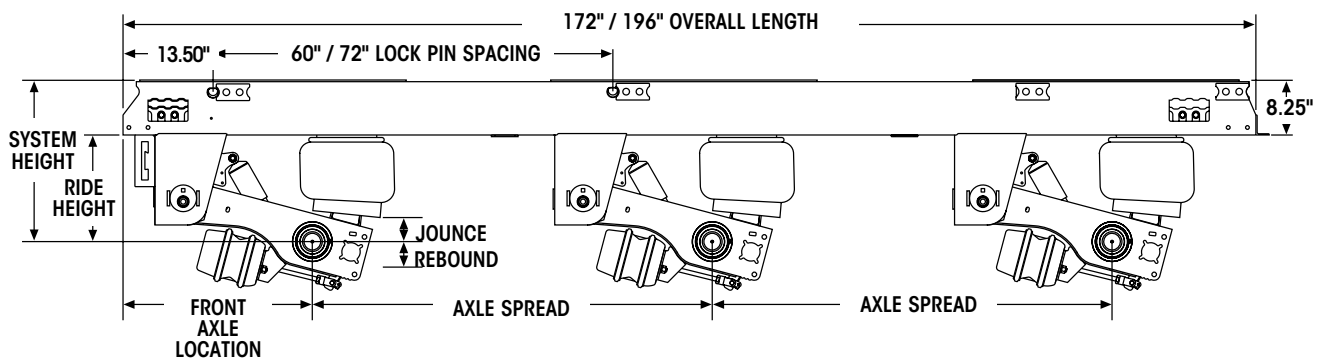



HKAT 69K25

SYSTEM CAPACITY*	69,000 lbs. (31 200 kg)
APPLICATION	On-highway or maintained roads
TRAILER TYPES	U.S.A. and Canada: Dry, refrigerated and specialty van Mexico, Central and South America: None
AXLE DATA	Diameter: 5.75-inch LDA™ Large-Diameter Axle Capacity: 25,000 lbs. (11 300 kg) Arrangement: Tridem Track: 71.5- and 77.5-inch Spread: 60- and 72-inch
FRAME TYPES	Steel only: 96- and 102-inch wide trailers (42- and 48-inch wide slider boxes)
BASE MODEL DESCRIPTION	VANTRAAX® HKAT 69K25 slider suspension system consisting of 72-inch spread, 48-inch wide slider box with three 16-inch ride height suspensions, 77.5-inch axle track, HN spindles, 16.5- x 7-inch brakes with H2O brake lining, ABS brackets, QUIK-ALIGN® pivot connection, QUIK-DRAW® pin-pull mechanism and standard Cam Tube System™.



*System capacity refers to the suspensions, axles and slider. Ratings for brakes and wheel-end components differ depending upon options chosen.

AXLE SPREAD (inches)	RISE HEIGHT (inches)	SYSTEM HEIGHT (inches)	FRONT AXLE LOCATION (inches)	JOUNCE (inches)	REBOUND (inches)	WEIGHT (pounds)
60	16	24.25	28.4	3.1	4.6	2,420
	17	25.25	28.0	3.0	3.6	2,427
72	16	24.25	28.4	3.1	4.6	2,479
	17	25.25	28.0	3.0	3.6	2,486

Note: Weight includes 48-inch wide slider, suspensions, HN LDA™ Large-Diameter Axle (5.75-inch) and foundation brake components (body rail weights not included). For a 42-inch wide slider system, deduct 66 pounds. For manual pin-pull mechanism, add 18 pounds for the 72-inch spread model and 14 pounds for the 60-inch model. For fixed-pin option, deduct 24 pounds for the 72-inch spread model and 26 pounds for the 60-inch spread model. Does not include SURELOK® or box shims.

SPECIFICATIONS

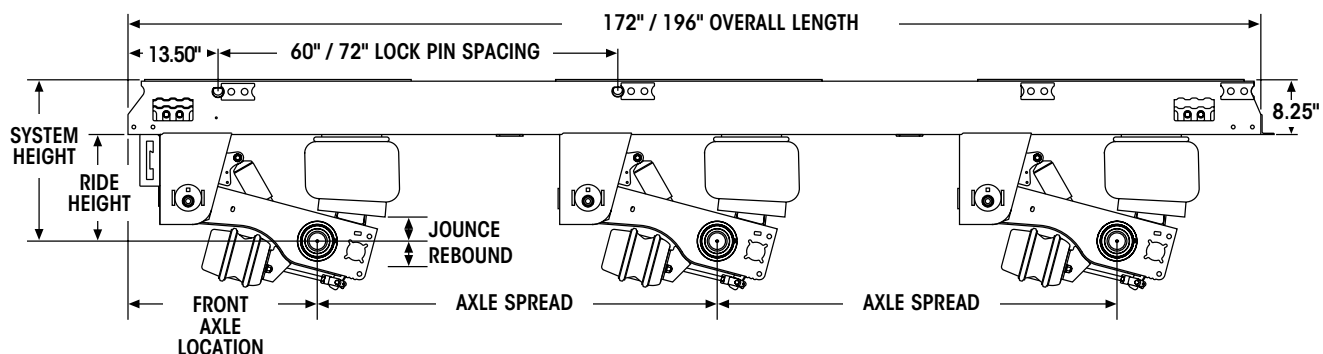



HKARL 46K

SYSTEM CAPACITY*	46,000 lbs. (20 700 kg)
APPLICATION	On-highway or maintained roads
TRAILER TYPES	U.S.A. and Canada: Dry, refrigerated and specialty van Mexico, Central and South America: None
AXLE DATA	Diameter: 5.75-inch LDA™ Large-Diameter Axle Arrangement: Tandem Track: 77.5-inch Spread: 49-inch
FRAME TYPES	Steel only: 96- and 102-inch wide trailers (48-inch wide slider boxes)
BASE MODEL DESCRIPTION	VANTRAA [®] HKARL 46K slider suspension system consisting of 49-inch spread, 48-inch wide slider box with 10- or 11-inch ride height suspensions, 77.5-inch axle track, HN spindles, 16.5- × 7-inch brakes with H2O brake lining, ABS brackets, QUIK-ALIGN [®] pivot connection, QUIK-DRAW [®] pin-pull mechanism and standard Cam Tube System™.



*System capacity refers to the suspension, axle and slider. Ratings for brakes and wheel-end components differ depending upon options chosen.

AXLE SPREAD (inches)	RISE HEIGHT (inches)	SYSTEM HEIGHT (inches)	FRONT AXLE LOCATION (inches)	JOUNCE (inches)	REBOUND (inches)	WEIGHT (pounds)
49	10	24.25	28.5	2.9	4.8	1,840
	11	25.25	28.5	3.0	4.2	1,856

Note: Weight includes 48-inch wide slider, suspensions, HN 5-inch axles and foundation brake components (body rail weights not included). 42-inch wide slider system not available. For manual pin-pull mechanism, add 14 pounds. For fixed-pin option, deduct 8 pounds. Does not include box shims.

SPECIFICATIONS

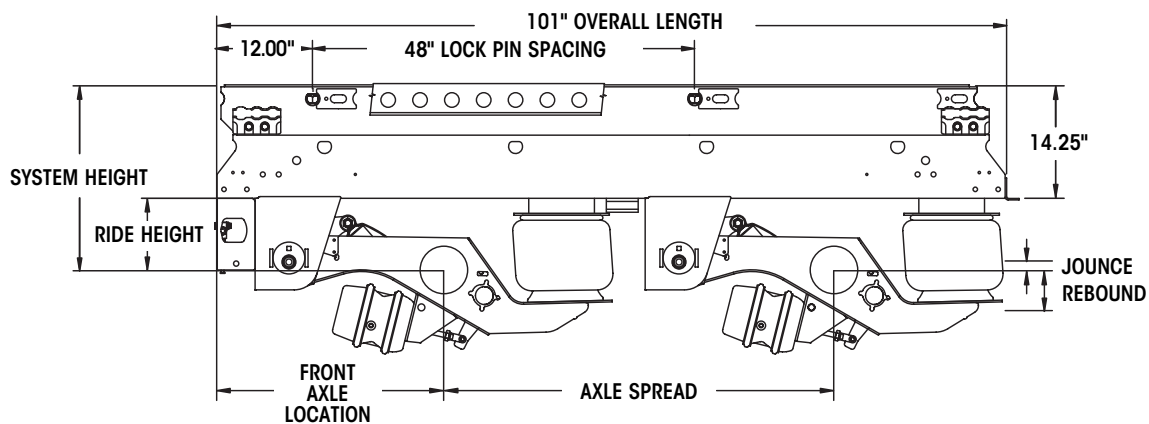



SPINDLE TYPE	TUBE O.D. (inches)	BEARINGS			
		INNER CONE	OUTER CONE	INNER CUP	OUTER CUP
HN	5.75	HM18248	HM212049	HM218210	HM212011
HP	5.75	HM518445		HM518410	

HENDRICKSON MAXX22T™

Hendrickson trailer air disc brake system specifically designed to optimize performance for North American trailer applications, with WABCO brake technology, features premium offerings including the lightweight Dura-Light Hub® option, TIREMAAX® and RTR® READY-TO-ROLL® wheel-end packages.

RTR® READY-TO-ROLL®

Choose from a broad mix of offerings to customize running gear for specific applications. Wheel-end options consist of aluminum, ductile iron or Dura-Light Hub® in a variety of standard and extended service wheel-end packages. The Outboard Mounted Rotor is an available option for units that specify HXL7® Extended-Life 7-Year System™ with MAXX22T air disc brakes. Refer to L1239 MAXX22T Flyer for more information.

BRAKE OPTIONS

For complete details on the wide range of brake options available including lining choices, brake ratings and FMVSS/CMVSS 121 brake certifications, refer to publication L809, *Brake Certifications*. Air disc brake packages not available on VANTRAAX® HKAL and HKANL models. Please contact Hendrickson for assistance.

BRAKE CHAMBERS

Industry standard brake chambers with pushrod length of 9.75-inches and clamping / port orientation of zero degrees are compatible except HKARL models which are specified with a pushrod length of 7 inches.

BRAKE ADJUSTERS

Industry standard 5.5- and 6-inch brake adjusters are compatible.

DUST SHIELD

Clamp-on dust shield provides protection for both drum and air disc brakes — factory or OEM installed.

ZMD® ZERO MAINTENANCE DAMPING® (HKANT 40K)

Innovative ride solution exclusively through Hendrickson that eliminates the shock absorbers by integrating the damping function into the air spring.

SURELOK®

Dock height lock that maintains trailer at deck height while minimizing trailer walk during loading and unloading.

RAMP-READY (HKARL 46K)

Eliminates need for heavy, expensive spacer tubes with built-in 30-inch by 6.5-inch ramp bay — 10- and 11-inch ride heights.

LOW-RIDE (HKAL 46K)*

Ideal for low-ride height applications — 10- and 11-inch ride heights.

HEIGHT CONTROL VALVES

For complete details on available height control valve kits, refer to publication L1182, *Controls Parts Catalog*.

STINGER

Bolt-on bracket available in 32- or 36-inch lengths — road and curbside mounting ready.

MANUAL STOP BAR

Efficiently assists the driver in slider box repositioning.

WELD-ON AIR TANK BRACKETS

Bracket kits available for customer installation; use with industry standard jumbo or small tanks Factory installed brackets available from Hendrickson; use with industry standard jumbo tanks.

SLIDER PIN EXTRACTOR

QUICK-DRAW® — fully pneumatic, pin-pull mechanism. Fixed-pin option — slider pins only for fixed van applications.

MUD FLAP MOUNTING ANGLE

Bolt-on bracket, attaches to rear cross member.

FACTORY PRE-ALIGNED SLIDERS

Ensures accurate parallelism between two neutral-toe axles.

SOFT-COAT FINISH

Provides superior protection against rust and corrosion.

* Please contact your Hendrickson customer service representative for component information.

*Actual product performance may vary depending upon vehicle configuration, operation, service and other factors.
All applications must comply with applicable Hendrickson specifications and must be approved by the respective vehicle manufacturer with the vehicle in its original, as-built configuration.
Contact Hendrickson for additional details regarding specifications, applications, capacities, and operation, service and maintenance instructions.*

Call Hendrickson at 866.RIDEAIR (743.3247) for additional information.



www.hendrickson-intl.com

TRAILER COMMERCIAL VEHICLE SYSTEMS

2070 Industrial Place SE
Canton, OH 44707-2641 USA
866.RIDEAIR (743.3247)
Fax 800.696.4416

Hendrickson Canada ULC

2825 Argentia Road, Unit #2 - 4
Mississauga, ON Canada L5N 8G6
800.668.5360
905.789.1030 • Fax 905.812.9423

Hendrickson Mexicana

Circuito El Marqués Sur #29
Parque Industrial El Marqués
Pob. El Colorado, Municipio El Marqués,
Querétaro, México C.P. 76246
+52 (442) 296.3600 • Fax +52 (442) 296.3601

L629 Rev N 02-24

© 1998 – 2024 Hendrickson USA, L.L.C. All Rights Reserved. All trademarks shown are owned by Hendrickson USA, L.L.C., or one of its affiliates, in one or more countries.
Information contained in this literature was accurate at the time of publication. Product changes may have been made after the copyright date that are not reflected.

Printed in United States of America