

H[®] SELECTION GUIDE

Equalizing Beam and Components

LIT NO: 45745-147

DATE: May 2026

REVISION: H

CONTENTS

DESCRIPTION	PAGE
Introduction	2
Fabricated and Forged/Cast Beams	3
Equalizing Beam End Bushings Service Kits.	4
Equalizing Beam Center Bushings and End Plugs	5
Equalizing Beam with Bar Pin End Bushings	6-7
Equalizing Beam with Adapter Style End Bushings.	8-9
Heavy-duty Equalizing Beam with Adapter Style End Bushings	10-11
Equalizing Beams with Rotatable Bar Pin End Bushings	12

Equalizing Beam with Rotatable Bar Pin End Bushing



Bar Pin End Bushing with Shims



Bar Pin End Bushing without Shims



High Confinement Rubber Center Bushings



Bronze Center Bushings



Adapter Style End Bushing



Equalizing Beam

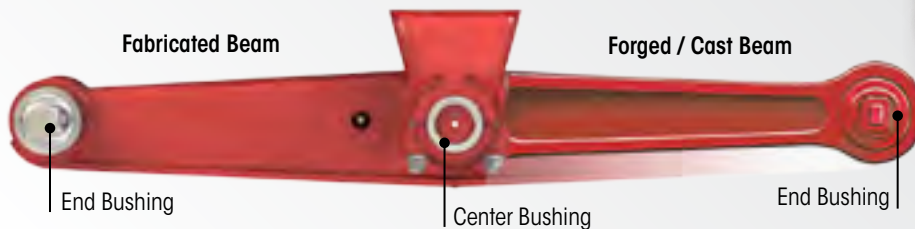

To learn more about Hendrickson Genuine Parts, call 855.743.3733 or visit www.hendrickson-intl.com

■ Introduction

This Equalizing Beam and Components Selection Guide is intended to aid in the proper identification for aftermarket replacement of originally equipped Hendrickson equalizing beams and other components. It helps determine the proper and complete beam assembly part numbers, end bushing service kit numbers and center bushing requirements.

■ Important Notes

- **Equalizing beams** are available for applicable Hendrickson suspensions with 34,000 pound to 120,000 pound capacity with axle spacing of 52"-72½". All Hendrickson equalizing beam assemblies include end bushings and center bushings (if equipped). Hendrickson **DOES NOT** supply equalizing beam assemblies without bushings.
- **Equalizing beam length** is measured from the centerline of one end hub to the centerline of the other end hub.

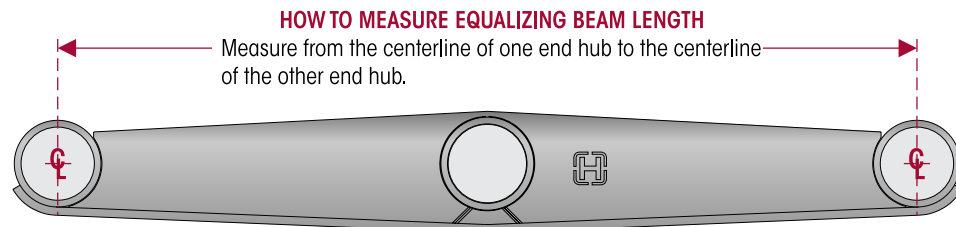

- **Fabricated equalizing beam** — Hendrickson introduced its fabricated equalizing beam design for up to 46,000 pound capacity between August 1999 and March 2000. In February 2008, it introduced a fabricated beam for 52,000 pound and up capacities. The fabricated beam is completely interchangeable with Hendrickson's discontinued forged beam.
- **Center bushing Part Number 29483-005** — **ALWAYS REQUIRES** the use of transverse torque rods. When using the fabricated style beams, the entire beam assembly must be replaced when converting from a rubber center bushing to a bronze center bushing to accommodate for the grease fitting and channel installation. **To convert** from rubber center bushings to bronze center bushings contact Hendrickson Truck Parts.
- **End bushings** — Both **shim and non-shim type Hendrickson bar pin** end bushings are completely interchangeable with **Hendrickson rotating bar pin** end bushings. Once pressed into the beam, the pins can be rotated to the correct angle for a perfect installation. The bushing pins become fixed at the required angle when the installation is properly completed. It helps save time and labor costs by eliminating re-work from incorrectly installed bushings. No special tools are required to rotate the bushing.



WARNING

FABRICATED BEAM ASSEMBLY ORIENTATION IT IS IMPORTANT THAT THE ORIENTATION OF THE BEAM BE IN THE UPRIGHT POSITION. A DECAL MAY BE AFFIXED TO THE TOP OF BEAM TO ASSIST IN ASSEMBLY AND TO VERIFY ORIENTATION. FAILURE TO INSTALL EQUALIZING BEAM PROPERLY MAY RESULT IN ADVERSE VEHICLE HANDLING AND POSSIBLE PERSONAL INJURY OR PROPERTY DAMAGE.



FABRICATED BEAMS

AR2™ • R™ • RS™ • RT™ • RTE™

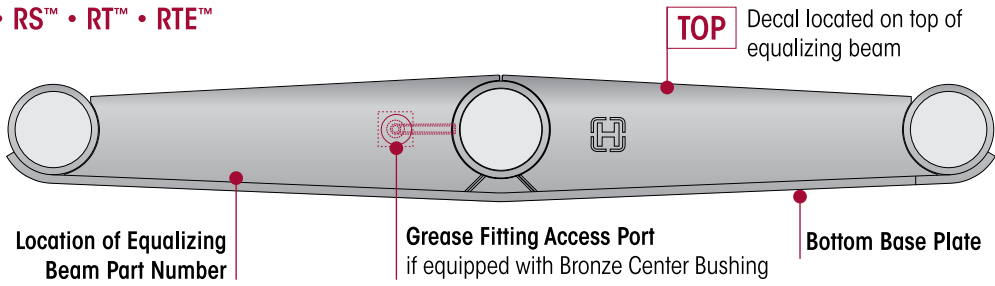

HAULMAAX® EX

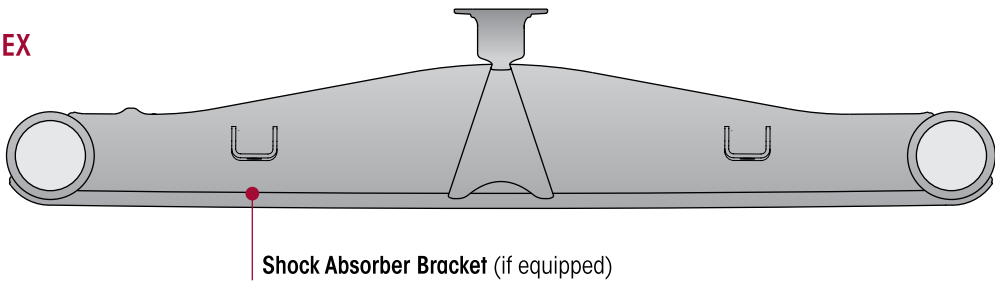

HAULMAAX®

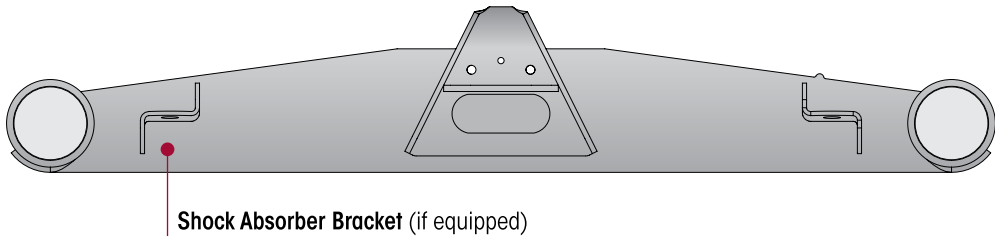

HN®

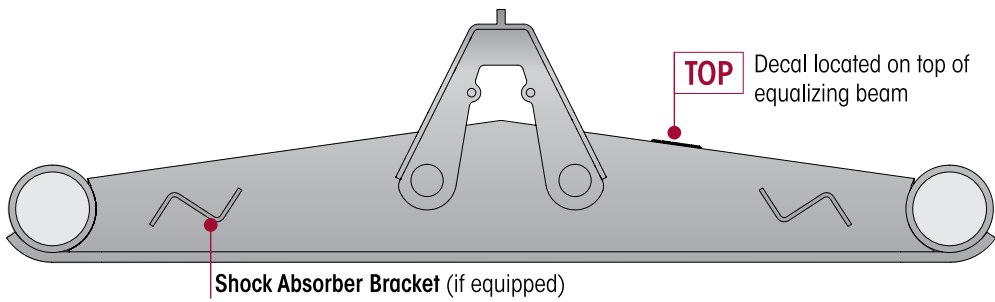

ULTIMAAX®

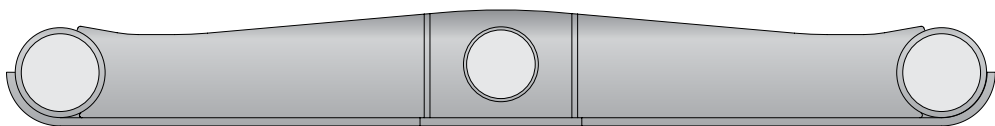

FORGED / CAST BEAMS

AR2 • R • RS • RT • RTE

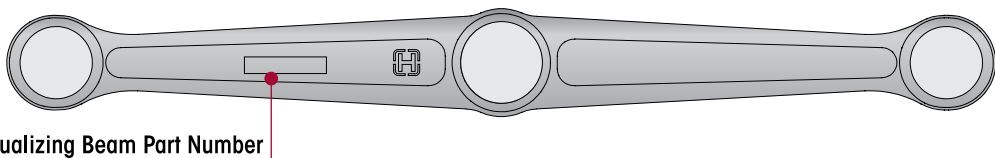



Equalizing Beam End Bushing Service Kits | AR2 • HAULMAAX EX • HAULMAAX • HN R • RS • RT • RTE • ULTIMAAX

Bar Pin End Bushing Service Kits

Two (2) kits required per beam

AR2 • HAULMAAX EX • HAULMAAX • HN • R • RS • RT • RTE

NON-SHIM TYPE



34013-087L

Qty.	Description
1	Bar Pin End Bushing
2	1"-8 UNC x 6" Hex Bolt
4	1" Hardened Washer
2	1"-8 UNC Locknut

SHIM TYPE, ROTATING BAR PIN



34013-188L

Qty.	Description
1	Bar Pin End Rotating Bushing
2	Bar Pin Shim 0.25" x 0.12"
2	1"-8 UNC x 6" Hex Bolt
4	1" Hardened Washer
2	1"-8 UNC Locknut

AR2 • HAULMAAX EX • HAULMAAX • HN R • RS • RT • RTE • ULTIMAAX
SHIM TYPE *Shown 34013-088L*



34013-088L • 60961-752 (ULTIMAAX Only)

Qty.	Description
1	Bar Pin End Bushing
2	Bar Pin Shim 0.25" x 0.12"
2	1"-8 UNC x 6" Hex Bolt
4	1" Hardened Washer
2	1"-8 UNC Locknut

Equalizing Beams End Bushing Service Kits | AR2 • R • RS • RT • RTE • ULTIMAAX

Adapter Style End Bushing Service Kits

Two (2) kits required per beam

HOW TO MEASURE ADAPTER STYLE END BUSHING LENGTH

Measure the end bushing to help determine the correct end bushing kit

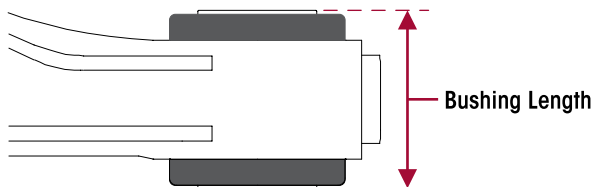

ADAPTER STYLE END BUSHING SERVICE KIT

Description	Quantity
Adapter Style End Bushing	1
Beam End Adapter	2
Adapter Tube	1
Hex Bolt	1
Hardened Washer	2
Locknut	1

CAPACITY RATING (lb)	END BUSHING LENGTH (in)	END BUSHING PART NUMBER	END BUSHING SERVICE KIT
34,000	5¼	06969-000L	34013-048
34,000 to 46,000	5¾	45900-000L	34013-049
46,000			34013-073
48,000 to 52,000	5¾	29878-001L	34013-050
52,000	6	45407-000L	34013-051
60,000 to 85,000	6	10363-000L	34013-052
	7	10364-000L	34013-110

Bronze Tube and Nut Style End Bushing Service Kits

44,000 to 90,000	4	04990-000	34013-056
			34013-057



Equalizing Beams Center Bushings | AR2 • R • RS • RT • RTE • ULTIMAAX

Bronze Center Bushing Service Kits

One (1) kit required per beam



BRONZE TUBE & NUT ENDS

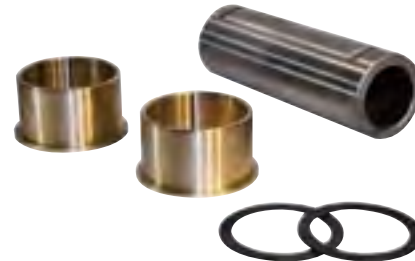

Kit No.	Capacity (lb)
34013-053	34K
34013-054	38K•40K•44K•46K
	48K•50K•52K
34013-055	65K

Qty.	Description
1	Bronze Center Bushing
1	Beam Center Sleeve
2	Beam Center Seal
4	Thrust Washer
1	Grease Fitting

Kit No.	Description
34013-080	Solid Sleeve
34013-081	Hollow Sleeve
34013-078	Solid Sleeve
34013-079	Hollow Sleeve

Qty.	Description
2	Bronze Center Bushing
1	Beam Center Sleeve
2	Thrust Washer

Rubber Center Bushings



Part No.	Capacity (lb)
	AR2 • R • RS • RT • RTE
06664-000L	34K•40K
49400-000L	34K•38K•40K
05919-000L	38K•40K
29483-005L	44K•46K•48K•50K•52K
10366-000L	65K
15464-000	85K
14110-000	100K•120K
	ULTIMAAX
69538-000L	46K•52K•54K•58K•60K•63K
78676-001	70K, includes Circlip (Not Shown)

Center Bushing End Plugs for Cross Tube Replacement | AR2 • R • RS • RT • RTE • ULTIMAAX

	SUSPENSION CAPACITY (lb)	RUBBER CENTER BUSHING ASSEMBLY PART NUMBER	END PLUG PART NUMBER	BRONZE CENTER SLEEVE PART NUMBER	END PLUG PART NUMBER
	* 34,000 through 54,000 Pound Capacity				
	34,000	06664-000L	22278-000	14684-000	22278-000
		22279-000L			
	38,000	05919-000L	22281-000	14685-000	57263-000
		22282-000L			
	40,000	+ 49400-000L			
		+ 49600-000L			
	46,000 to 52,000	29483-005L			
		34013-097L			

* On heavy-duty suspensions over a 52,000 pound capacity, Hendrickson recommends removal of both equalizing beams as part of cross tube replacement. Therefore center bushing end plugs are not available for these higher capacity suspensions. Refer to the applicable Technical Procedure Publications available online at www.hendrickson-intl.com for more information.

+ High confinement bushings.



Fabricated Equalizing Beams with Bar Pin End Bushings | AR2 • R • RS • RT • RTE • ULTIMAAX

	EQUALIZING BEAM LENGTH (in)	FABRICATION NUMBER	ASSEMBLY PART NUMBER		RUBBER / BRONZE CENTER BUSHING PART NUMBER	★ BAR PIN END BUSHING KIT NUMBER
			ORIGINAL	REPLACEMENT		
RUBBER CENTER BUSHING	AR2 • R • RS • RT • RTE 34,000 • 40,000 Pound Capacity					
	52	60855-002	50000-024		06664-000L	34013-087L
			50500-024			34013-088L
			◆ 50000-025	50500-025	49400-000L	
	54	60855-001	◆ 50000-027	◆ 50500-027	06664-000L	34013-087L
			50000-028			34013-088L
	56	67453-002	◆ 50000-010	50500-010	49400-000L	34013-087L
	★ 60	58755-003	50000-030			34013-088L
			50500-030			34013-087L
	★ 72½	29585-007	◆ 50000-014	50500-014		34013-088L
	AR2 • R • RS • RT • RTE 46,000 Pound Capacity					
	52	60855-002	◆ 50000-026	50500-026	★ 29483-005L	34013-088L
	54	60855-001	50000-029			34013-087L
			50500-029			34013-088L
	★ 72½	29585-007	50000-015			34013-087L
			50500-015			34013-088L
AR2 • R • RS • RT • RTE 48,000 • 50,000 • 52,000 Pound Capacity						
52	67091-520	50500-039		★ 29483-005L	34013-088L	
54	67091-540	50500-040			34013-087L	
★ 60	58755-003	50000-031			34013-088L	
		50500-031				
★ 72½	31121-030	◆ 50000-016	50500-016			
ULTIMAAX 46,000 • 52,000 • 54,000 • 58,000 Pound Capacity						
52	78488-520	78489-520		69538-000L	60961-752	
54	78488-540	78489-540				
56	78488-560	78489-560				
60	78488-600	78489-600				

BRONZE CENTER BUSHING	AR2 • R • RS • RT • RTE 40,000 • 46,000 Pound Capacity					
	52	67453-002	50001-015		34013-054	34013-087L
			50501-015			34013-088L
	54	67453-001	50001-017			34013-087L
			50501-017			34013-088L
	AR2 • R • RS • RT • RTE 48,000 • 50,000 • 52,000 Pound Capacity					
	52	67091-521	50501-021		34013-054	34013-088L
	54	67091-541	50501-022			



Fabricated Equalizing Beams with Bar Pin End Bushings | HAULMAAX • HN

EQUALIZING BEAM LENGTH (in)	STYLE	FABRICATION NUMBER	ASSEMBLY PART NUMBER	★ BAR PIN END BUSHING KIT NUMBER
HAULMAAX 40,000 • 46,000 Pound Capacity				
52	With Shock Bracket	64830-003	64846-003	34013-088L
54		64830-001	64846-001	
60		64830-002	64846-002	
72½		64830-004	64846-010	
52	Without Shock Bracket	64836-003	64847-003	
54		64836-001	64847-001	
		64836-001	64847-004	
60		64836-002	64847-002	
72½		64830-004	64847-010	
HN 40,000 Pound Capacity				
52		58348-002	57889-004	34013-087L
			57889-005	34013-088L
			57889-008	34013-088L
54		58348-001	57889-001	34013-087L
			57889-002	34013-088L
HN 40,000 • 46,000 Pound Capacity				
60		58684-001	58494-005	34013-087L
			58494-006	34013-088L
72½		58711-001	58494-009	34013-087L
			58494-010	34013-088L
HN 46,000 Pound Capacity				
54		58409-001	58494-001	34013-087L
			58494-002	34013-088L
HN 52,000 Pound Capacity				
54		59972-001	59973-003	34013-088L

HAULMAAX EX • HAULMAAX • HN BAR PIN STYLE END BUSHING KITS



BAR PIN END BUSHING with Shims



34013-188L Rotating Bar Pin



34013-088L



HAULMAAX • HN Only 34013-087L

- ★ Requires transverse torque rods.
- ◆ Part number no longer in production, see Replacement Column or contact Hendrickson Truck Parts for available options.
- ⊛ Rotating bar pin end bushing with shims Kit Number 34013-188L can be used to replace Kit Numbers 34013-088L or 34013-087L and are completely interchangeable.



Fabricated Equalizing Beams with Adapter Style End Bushings | AR2 • R • RS • RT • RTE

EQUALIZING BEAM LENGTH (in)	FABRICATION NUMBER	ASSEMBLY PART NUMBER		RUBBER CENTER BUSHING PART NUMBER	ADAPTER END BUSHING KIT NUMBER	END BUSHING LENGTH (in)
		ORIGINAL	REPLACEMENT			
AR2 • R • RS • RT • RTE 34,000 Pound Capacity						
50	29584-007	◆ 07500-591		06664-000L	34013-048	5½ & 5¾
		◆ 07500-592			34013-049	
52	60855-002	07500-593				
54	60855-001	◆ 07500-596				
60	✚ 47480-000	07500-491				
AR2 • R • RS • RT • RTE 38,000 • 40,000 Pound Capacity						
50	29585-027	◆ 07500-458		05919-000L	34013-049	5¾
52	60855-002	07500-594		49400-000L		
54"	60855-001	07500-597				
★ 60	58755-003	07500-599				
★ 72½	29585-007	07500-553				
AR2 • R • RS • RT • RTE 44,000 • 46,000 Pound Capacity						
52	60855-002	07500-595		★ 29483-005L	34013-049	5¾
54	60855-001	07500-598				
★ 60	58755-003	07500-600				
1700 mm	56735-000	07500-576				
★ 72½	29585-007	07500-474				
AR2 • R • RS • RT • RTE 48,000 • 52,000 Pound Capacity						
52"	67091-520	07500-606		★ 29483-005L	34013-050	5¾
54"	67091-540	07500-608				
★ 60	58755-003	07500-602				
★ 72½	31121-030	07500-511				
AR2 • R • RS • RT • RTE 52,000 Pound Capacity						
52	67091-520	07500-607		★ 29483-005L	34013-051	6
54	67091-540	◆ 07500-609				
★ 60	58755-003	07500-603				
★ 72½	31121-030	◆ 07500-541	07500-474		34013-050	
76	31121-024	07500-524				
80	31121-032	07500-605				

RUBBER CENTER BUSHING

✚ Cast equalizing beam.

★ Requires transverse torque rods.

◆ Part number no longer in production, see Replacement Column or contact Hendrickson Truck Parts for available options.



Fabricated Equalizing Beams with Adapter Style End Bushings | AR2 • R • RS • RT • RTE

EQUALIZING BEAM LENGTH (in)	FABRICATION NUMBER	ASSEMBLY PART NUMBER		BRONZE CENTER BUSHING KIT NUMBER	ADAPTER END BUSHING KIT NUMBER	END BUSHING LENGTH (in)
		ORIGINAL	REPLACEMENT			
AR2 • R • RS • RT • RTE 34,000 Pound Capacity						
52	58755-002	30247-150	30247-151	34013-053	34013-049	5½ & 5¾
54	59068-001	30247-153				
AR2 • R • RS • RT • RTE 38,000 • 40,000 • 44,000 • 46,000 Pound Capacity						
50	46325-006	◆ 30247-111		34013-054	34013-049 with ¾" x 6½" Bolt 34013-073 with 1" x 10½" Bolt	5¾
52	67453-002	30247-151				
54	67453-001	30247-153				
AR2 • R • RS • RT • RTE 48,000 • 52,000 Pound Capacity						
52	67091-521	30247-154		34013-054	34013-050	5¾
		30247-155			34013-051	6
54	67091-541	30247-156			34013-050	5¾
		30247-157			34013-051	6

BRONZE CENTER BUSHING

AR2 • R • RS • RT • RTE



Bronze Center Bushing Kits

Kit Number	Capacity (lb)
34013-053	34K
34013-054	38K through 52K
34013-055	65K

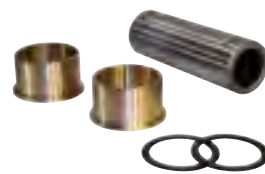

Bronze Center Bushing Kits for Tube and Nut Ends

Kit Number	Description
34013-080	Solid Sleeve
34013-078	Solid Sleeve
34013-081	Hollow Sleeve
34013-079	Hollow Sleeve



Adapter Style End Bushing Kits

Kit Number	Capacity (lb)
34013-048	34K
34013-049	34K through 46K
34013-073	46K
34013-050	48K through 52K
34013-051	52K
34013-052	60K through 85K
34013-110	60K through 85K

Bronze Tube and Nut Style

34013-056	44K through 90K
34013-057	44K through 90K



◆ Part number no longer in production, see Replacement Column or contact Hendrickson Truck Parts for available options.

Heavy-duty Equalizing Beams with Adapter Style End Bushings | R • RS • RT • RTE

EQUALIZING BEAM LENGTH (in)	STYLE	CASTING/FABRICATION NUMBER	ASSEMBLY PART NUMBER		BRONZE CENTER BUSHING KIT NUMBER	ADAPTER END BUSHING KIT NUMBER	TOTAL OFFSET "A" (in)	END BUSHING LENGTH (in)
			ORIGINAL	REPLACEMENT				
R • RS • RT • RTE 65,000 Pound Capacity								
56	Fabricated	68650-561	◆ 30247-106	30247-159	34013-055	34013-052	2¾	6
60		68650-601	◆ 30247-094	30247-161				
72		31122-020	30247-130					
56	Fabricated	68650-561	◆ 30247-121	30247-162	34013-055	34013-110	3¼	7
60		68650-601	◆ 30247-158	30247-160				

BRONZE CENTER BUSHING

Heavy-duty Equalizing Beams with Tube and Nut Ends | R • RS • RT • RTE

R • RS • RT • RTE 44,000 • 52,000 • 60,000 • 90,000 Pound Capacity									
50	Fabricated	30934-000	◆ 30644-001		34013-054	34013-056	0		
52	Forged/ Cast	34876-000	◆ 30644-003						
		33197-000	32649-000						
54		◆ 11755-002	◆ 07600-011		34013-080 Solid Sleeve 34013-081 Hollow Sleeve	34013-057	2		
56	Fabricated	46450-011	◆ 30644-008		34013-054	34013-056			
58				07600-132		34013-080 Solid Sleeve 34013-081 Hollow Sleeve			34013-057
			◆ 26997-000		◆ 07600-133	34013-078 Solid Sleeve 34013-079 Hollow Sleeve			

FIGURE 1 OFFSET

TOP VIEW

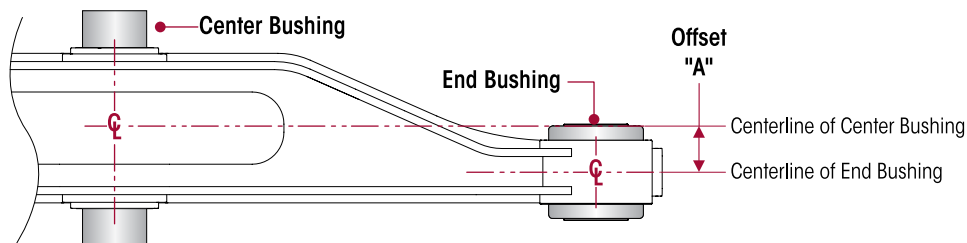

◆ Part number no longer in production, see Replacement Column or contact Hendrickson Truck Parts for available options.



Heavy-duty Equalizing Beams with Adapter Style End Bushings | R • RS • RT • RTE • ULTIMAAX





EQUALIZING BEAM LENGTH (in)	STYLE	CASTING/FABRICATION NUMBER	ASSEMBLY PART NUMBER		RUBBER CENTER BUSHING PART NUMBER	ADAPTER END BUSHING KIT NUMBER	TOTAL OFFSET "A" (in)	END BUSHING LENGTH (in)			
			ORIGINAL	REPLACEMENT							
R • RS • RT • RTE 65,000 Pound Capacity											
50	Fabricated	31122-002	07500-116		10366-000L	34013-052	1½	6			
54		31122-016	07500-454				2¾				
		31122-017	07500-482				1½				
56	Cast	68650-560	◆ 07500-198	07500-613			10366-000L		34013-052	2¾	6
		59409-000	◆ 07500-446							2¼	
			07500-601								
60		68650-600	◆ 07500-453	07500-612						2¾	
64	Fabricated	31122-010	07500-399				1½				
75		31122-009	07500-378				2				
56	Fabricated	68650-560	◆ 07500-490	07500-614	10366-000L	34013-110	3¼	7			
60		68650-600	◆ 07500-400	07500-611							
64		31122-010	◆ 07500-532								
72		31122-003	◆ 07500-214								
		31122-022	07500-581								
R • RS • RT • RTE 85,000 Pound Capacity											
56	Fabricated	69250-002	◆ 07500-104	07500-617	15464-000	34013-110	2	7			
58		69250-005	◆ 07500-157	07500-620							
60		69250-001	◆ 07500-182	07500-616							
		65410-000	07500-604								
64		69250-003	◆ 07500-180	07500-618							
72		69250-006	◆ 07500-068	07500-624							
75		69250-004	◆ 07500-432	07500-619							
R • RS • RT • RTE 100,000 • 120,000 Pound Capacity											
64	Fabricated	67878-000	07500-579		14110-000	15424-000	3	7¾			
80		69571-000	◆ 07500-577	07500-615							
ULTIMAAX 60,000 • 63,000 • 70,000 Pound Capacity											
54	Fabricated	78633-540	78634-540		69538-000L	34013-052		6			
56		78633-560	78634-560								
60		78633-600	78634-600								
56		78633-560	80291-560								
60		78633-600	80291-600			34013-110					
56		78633-560	80192-560								
60		78633-600	80192-600								
		78633-600	80192-600								

◆ Part number no longer in production, see Replacement Column or contact Hendrickson Truck Parts for available options.



Aftermarket Equalizing Beams with Rotatable Bar Pin End Bushings | HAULMAAX EX • HAULMAAX • HN • RT/RTE • RS • R

Hendrickson offers rotatable bar pin end bushings on select equalizing beams for service with the exact equalizing beam used in production that provides structural integrity and functionality to maintain the original system performance.

	CAPACITY (lb)	EQUALIZING BEAM LENGTH (in)	PART NUMBER								
			Equipped with Shock Bracket		Equipped without Shock Bracket						
			PRODUCTION	SERVICE	PRODUCTION	SERVICE					
HAULMAAX EX											
	40,000	52	-	-	-	-					
		54									
	46,000	52									
		54									
		60									
		72.5									
	52,000	52									
		54									
		60									
	HAULMAAX										
		40,000					54	64846-001	80225-001	64847-001	80226-001
		46,000								64847-004	
HN											
	40,000	52	-	-	57889-008	80228-008					
	46,000	54			58494-002	80227-002					
RT • RTE • RS • R											
	46,000 with Bronze Center Bushing	52	-	-	50501-015	80476-015					
		54			50501-017	80476-017					
	46,000 with Rubber Center Bushing	52	-	-	50500-026	93024-026					
		54			50500-029	93024-029					

Actual product performance may vary depending upon vehicle configuration, operation, service and other factors. All applications must comply with applicable Hendrickson specifications and must be approved by the respective vehicle manufacturer with the vehicle in its original, as-built configuration. Contact Hendrickson for additional details regarding specifications, applications, capacities, and operation, service and maintenance instructions.

Call Hendrickson at 630.910.2800 or 855.RIDERED (855.743.3733) for additional information.



www.hendrickson-intl.com

TRUCK COMMERCIAL VEHICLE SYSTEMS
 800 South Frontage Road
 Woodridge, IL 60517-4904 USA
 855.743.3733 (Toll-free U.S. and Canada)
 630.910.2800 (Outside U.S. and Canada)
 Fax 630.910.2899

45745-197 Rev H 05-26

© 2001 – 2026 Hendrickson USA, L.L.C. All Rights Reserved. All trademarks shown are owned by Hendrickson USA, L.L.C., or one of the affiliates, in one or more countries. Information contained in this literature was accurate at the time of publication. Product changes may have been made after the copyright date that are not reflected.

Printed in United States of America