

H APPLICATION GUIDE

HENDRICKSON AIR DISC BRAKES

LIT NO: L1225

DATE: October 2022

REVISION: I



TABLE OF CONTENTS

Introduction.....	2	Height Control Valve Requirements.....	6
Purpose	2	TRLAXLE® Non-Integrated Axle Brake Caliper Position ...	7
Important Notice.....	2	Wheel and Valve Stem	7
Questions.....	2	Trailer Brake Air Line Routing	7
Changes to Guidelines.....	2	Air Disc Brake Wheel-End System Options.....	8
Air Disc Brake Option	3	Hendrickson ADB Options Matrix.....	8
Brake Ratings	3	Air Disc Brake Warranty	9
Air Disc Brake Ordering Guide / Application Release Form.....	3	Air Disc Brake Package Weights Compared to Drum Brakes.....	10
Suspension and Axle Availability	4	Air Disc Brake vs. Drum Brake Weight Comparison	10
Suspension and Axle Specification Requirements.....	5	Closing	10
Additional Component Requirements	5		



INTRODUCTION

Hendrickson presents this publication to aid in understanding Hendrickson's Air Disc Brake (ADB) product offering and application requirements. Hendrickson offers ADB packages for several wheel-end systems to meet virtually any application or technology requirement.

PURPOSE

The purpose of this document is to provide original equipment manufacturers (OEMs) of medium and heavy-duty vehicles with application guidelines for Hendrickson Air Disc Brakes.

The descriptions and specifications contained in this publication are current at the time of printing.

Hendrickson reserves the right to discontinue or modify its models and / or procedures and to change specifications at any time without notice.

Any references to brand names in this publication are made as an example of the types of tools and materials recommended for use and should not be considered an endorsement. Equivalents may be used.

IMPORTANT NOTICE

Hazard signal words (such as Warning or Caution) appear in various locations throughout this publication. Information accented by one of these signal words must be observed at all times.

Additional notes are utilized to emphasize areas of procedural importance and provide suggestions for ease of repair. The following definitions indicate the use of these signal words as they appear throughout the publication.

⚠ WARNING: INDICATES HAZARDS OR UNSAFE PRACTICES WHICH COULD RESULT IN SEVERE PERSONAL INJURY OR DEATH.

⚠ CAUTION: Indicates hazards or unsafe practices which could result in damage to equipment or minor personal injury.

☑ NOTE: Additional service information not covered in the service procedures.

QUESTIONS

For answers to questions concerning these guidelines, for information not covered in these guidelines or to request a Hendrickson Trailer Ordering Guide, contact:

Hendrickson Trailer Commercial Vehicle Systems
2070 Industrial Place SE
Canton, OH 44707-2641
Telephone: 866-743-3247 (866-RIDE-AIR)
Website: www.hendrickson-intl.com

CHANGES TO GUIDELINES

These guidelines are subject to change at any time without prior notice at the discretion of Hendrickson. To get the most up-to-date version of these guidelines visit www.hendrickson-intl.com.



AIR DISC BRAKE OPTION

Hendrickson offers the following ADB systems for 17.5"* , 19.5" , 22.5" and 24.5" wheels:

1. Hendrickson MAXX22T™

This system uses a 415mm diameter rotor that is compatible with 22.5" or 24.5" wheels and will fit dual or wide base tires.

2. WABCO PAN22-1

This system uses a 430mm diameter rotor that is compatible with 22.5" or 24.5" wheels and will fit dual or wide base tires.

3. Knorr/Bendix ADB22X-LT

This system uses a 430mm diameter rotor that is compatible with 22.5" or 24.5" wheels and will fit dual or wide base tires. Knorr/Bendix ADB22X-LT is not approved for dolly applications.

4. WABCO PAN19

This system uses a 375mm diameter rotor that is compatible with 19.5" wheels and will fit dual or wide base tires.

5. Haldex ModulT (DBT22LT)

This system uses a 430mm diameter rotor that is compatible with 22.5" or 24.5" wheels and will fit dual or wide base tires.

6. Haldex ModulX (DB22)

This system uses a 430mm diameter rotor that is compatible with 22.5" or 24.5" wheels and will fit dual or wide base tires.

**Reference WABCO PAN17 Application Guide, L1272, for 17.5" wheels.*

BRAKE RATINGS

Hendrickson MAXX22T, WABCO PAN22-1, Knorr / Bendix ADB22X-LT, Haldex ModulT (DBT22LT), Haldex ModulX (DB22), WABCO PAN17 and WABCO PAN19 each use a specific brake pad lining and brake chamber tuned for each respective ADB package to achieve the desired brake rating.

For a complete list of all ADB brake rating certifications for FMVSS-121 (USA), CMVSS-121 (Canada) and ECE R13 (Europe), please reference Hendrickson literature number *L809 – Consolidated Certificate of Compliance for Air Actuated Brakes*. This document is available on Hendrickson's website at www.hendrickson-intl.com.

AIR DISC BRAKE ORDERING GUIDE / APPLICATION RELEASE FORM

To order ADB packages from Hendrickson, customers are required to complete and submit an ordering guide. In some cases, an application approval is also required using one of the ADB approval methods (listed below):

- A. Pre-Approval (per disc brake manufacturer requirements)
- B. Online Approval
- C. Waiver (found on the last page of the product ordering guide)
- D. Application form (found on the last page of the product ordering guide)

This application approval is required by our ADB suppliers who use this information to fully understand the trailer application as well as the brake balancing characteristics between the tractor and trailer.

NOTE: The application approval is not required for the Hendrickson MAXX22T system. The MAXX22T is approved for use in on-highway applications using the approved brake ratings.



SUSPENSION AND AXLE AVAILABILITY

The table below provides a summary of the suspension systems and axle models available with air disc brakes.

NOTE: Hendrickson MAXX22T™, WABCO PAN22-1, Haldex ModulT (DBT22LT) ModulX (DB22) or WABCO PAN19 must be specified for all dolly applications. Bendix does not approve the use of the ADB22X-LT in dolly trailer applications.

HENDRICKSON SUSPENSIONS AND AXLES AVAILABLE WITH ADB	
SUSPENSION / AXLE MODELS	AVAILABILITY
INTRAAX®	
AANT 23K	Requires unique HCV
AANLS 20K / AANL 23K	Requires rear mounted shocks and unique HCV
AAT 23K, 25K, 30K	ADB OK without SURELOK® — requires unique HCV
AAL 23K, 25K, 30K	Requires rear mounted shocks
AAEDL 30K* / AAEDT 30K*	Requires rear mounted shocks
INTRAAX® SP	
AAZNT 23K, 46K	Requires unique HCV
AAZNT 69K	ADB OK
AAZL 23K, 46K	Not available
ULTRAA-K®	
ULTRAA-K® UTKNT 40K**	ADB OK
VANTRAAX®	
HKANT 23K, 40K, 46K**	Requires unique HCV
HKANT 69K23**	ADB OK
HKAT 50K**	ADB OK without SURELOK — requires unique HCV
HKAT 69K25, HKARL**	ADB OK without SURELOK
HKANL, HKAL**	Not available
CONNEX™ ST	
CXSL 25K	Not available
HT™ SERIES	
HT250YB	Call for application approval
HT250T	Brake chambers in forward position only
HT230T, HT300T	ADB OK
HT250U, HT250UB	Call for application approval
HT190U, HT250US, HT300US	Not available
HT250Y, HT250YS, HT300YB	Not available
TRLAXLE®	
TRLAXLE — ½", ⅝", ⅝" HD wall	ADB available on limited tracks
TRLAXLE — ¾" wall	Not available
TIREMAAX®	
TIREMAAX CP, TIREMAAX PRO	ADB OK
* Not available with Hendrickson MAXX22T.	
** Not available with WABCO PAN19.	



SUSPENSION AND AXLE SPECIFICATION REQUIREMENTS

The chart below outlines the axle tracks available for suspension and axle systems equipped with ADBs.

MODELS	AXLE TRACK
VANTRAAX®	71.5", 77.5" and 83.5"
INTRAAX®	71.5", 73", 75.5", 76.5", 77.5", 83.5" and 85"
TRLAXLE®	
ULTRAA-K®	77.5"

ADDITIONAL COMPONENT REQUIREMENTS

Hendrickson requires all ADB equipped suspensions and axles to be fitted with dust shields and ABS sensors. Whereas ABS sensors for drum brakes are "right angle" 90-degree shaped, sensors for ADB are "straight" shaped. Depending on caliper brand, ABS sensing may be done by hub-mounted tone rings or rotor-mounted tone rings.

"Straight" ABS Sensor for ADB



90-Degree ADB Sensor for Drum Brakes

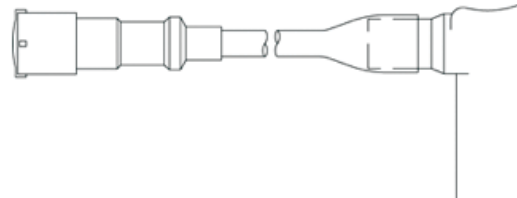



HEIGHT CONTROL VALVE REQUIREMENTS

Some ADB-equipped suspensions require a unique height control valve (HCV) mounting kit. These HCV kits are unique because of the lower mount connection. On drum brakes, the HCV usually mounts to the brake chamber bracket. With ADB, there is no brake chamber bracket, so the HCV mounts to the axle using a band clamp arrangement. Suspension models that require a unique kit are referenced in the chart below.

INTRAAX®
AANT 23K
AAT 23K/25K/30K
AANL 23K
AANLS 20K
VANTRAAX®
HKANT 23K/40K/46K
HKAT 50K
INTRAAX® SP
AAZNT 23K/46K
Refer to Hendrickson literature number <i>L1024 - Height Control Valves</i> or <i>L1182 - Controls Parts Catalog</i> on the Hendrickson website for more information.

The following drawings show the difference between typical ADB suspension HCV mounting kits versus drum brake suspension HCV mounting kits.

HCV Mounting for ADB

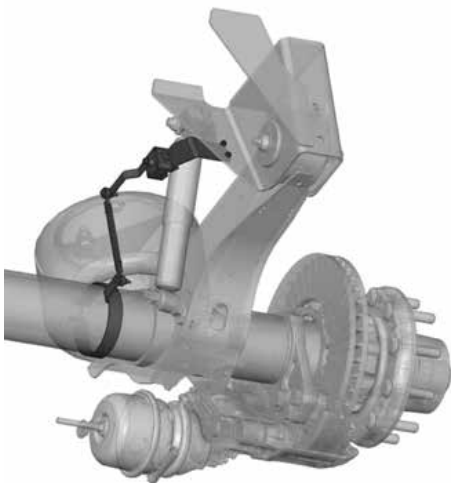

Conventional HCV Mounting for Drum Brake

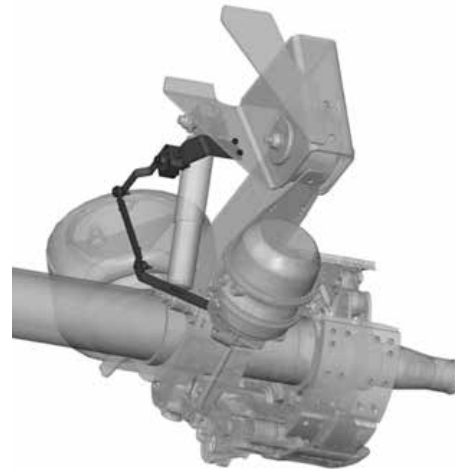

NOTE: Additional restrictions may apply; please contact Hendrickson Customer Service for assistance.



TRLAXLE® NON-INTEGRATED AXLE BRAKE CALIPER POSITION

Brake caliper position is an important piece of information Hendrickson needs to fully configure an ADB-equipped non-integrated suspension or axle. Customers must select the brake caliper position as shown in the drawings below to ensure proper orientation of the brake chamber per the specification ordered by the end user.

- A. For top-mount mechanical suspensions or top-mount air suspensions with brake chamber to the REAR of the axle and below the beam.

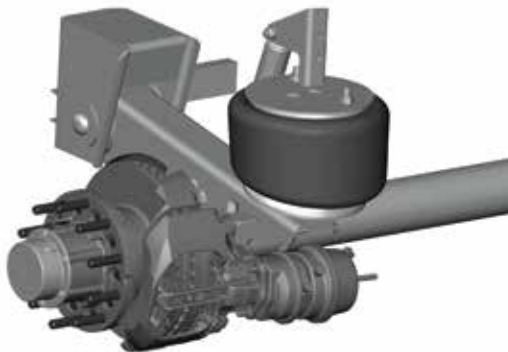

- B. For top-mount air suspensions with brake chamber to the FRONT of the axle and below the beam.



- C. For low-ride / underslung air suspensions with brake chamber to the FRONT of the axle and above the beam.

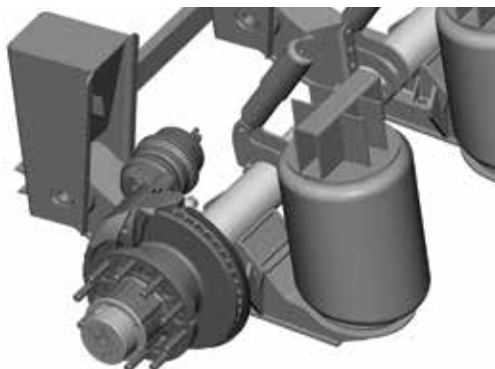

These can also be found at the bottom of page 7 of L964 Hendrickson Trailer Axles Ordering Guide.

⚠ CAUTION: For underslung mechanical suspensions, call Hendrickson and the suspension supplier.

✓ NOTE: For all caliper positions shown, the tire inflation holes are located on top dead center of axle when suspension is at ride height. Customer should verify brake chamber clearance at the entire suspension travel range. On Figure C, the shock cannot be mounted in front of the axle on underslung suspensions due to interface with the brake chamber.

WHEEL AND VALVE STEM

⚠ WARNING: Great care must be taken in selecting combinations of wheel and valve stem products that are compatible with ADB. Improper wheels or valve stems can interfere with air disc brakes and cause rapid tire deflation, component damage, a loss of vehicle control, PROPERTY DAMAGE OR SEVERE PERSONAL INJURY. Use only wheels and valve stems that provide proper running clearance with air disc brakes equipped on the suspension. Each brake manufacturer has compiled a list of approved wheel and valve stem combinations that can be selected during the approval process. If a wheel and valve stem combination is not available, please contact the brake manufacturer for approval. You may also contact the vehicle or brake manufacturer to determine replacement wheels and valve stems approved for the application.

TRAILER BRAKE AIR LINE ROUTING

⚠ WARNING: Great care must be taken when installing brake chamber air lines. Brake air lines must be installed to ENSURE FREE MOVEMENT of the caliper over its entire stroke. Attach brake hose to the brake chamber according to chamber manufacturer's specifications.



AIR DISC BRAKE WHEEL-END SYSTEM OPTIONS

Hendrickson offers ADB packages in combination with several wheel-end systems:

- Standard service wheel-end
- HXL Hendrickson Extended-Life wheel-end
- Conmet PreSet wheel-end

The specific options for each are shown in the Hendrickson ADB Options Matrix, listed below.

HXL7® Hendrickson Extended-Life 7-Year System™ is an industry exclusive system that combines Hendrickson’s engineering and manufacturing expertise with high-performance wheel-end components to create a system that delivers reliability and performance mile after mile.

HXL5® Hendrickson Extended-Life 5-Year System™ and **HXL3® Hendrickson Extended-Life 3-Year System™** are wheel-end packages, like HXL7, that offer the convenience of a single supplier for support and peace of mind from the most trusted name in the trailer industry.

Conmet PreSet ADB Wheel-End Systems

Hendrickson offers the Conmet PreSet wheel-end system with two options:

1. PreSet Aluminum Hub
2. PreSet Ductile Iron Hub

The Aluminum PreSet hub is available on both WABCO PAN22-1 ADB, Haldex Modul T (DBT22LT) and Knorr / Bendix ADB22X-LT ADB packages. The ductile iron PreSet hub is only available on the Knorr / Bendix ADB22X-LT package on an HP spindle.

For USA and Canada on-highway applications, the Conmet PreSet ADB wheel-end systems carry a limited five-year parts and one-year labor warranty on the hub, seal and bearings, excluding all normal wear. For areas outside the USA and Canada, Conmet PreSet ADB wheel-end systems carry a limited one-year parts and labor warranty on the hub, seal and bearings, excluding all normal wear. You may contact Conmet directly for ADB wheel-end warranty administration.

HENDRICKSON ADB OPTIONS MATRIX								
ADB OFFERING	Hendrickson MAXX22T™, PAN19, PAN22-1, Haldex ModulT, Haldex ModulX, Bendix ADB22X-LT				MAXX22T	ADB22X-LT		ADB22X-LT, PAN22-1 or Haldex ModulT
	Wheel-End Package	Standard 1 Year*	HXL3®	HXL5®	HXL7®**	HXL7®**	ConMet PreSet	
On-Highway	1 Year	3 Year	5 Year	7 Year	7 Year	5 Year Limited		
Off-Highway	1 Year	1 Year	3 Year	3 Year	3 Year			
Rotor Mounting	Inboard Mount				Outboard Mount	Inboard Mount		
Rotor Type	U-Shape Cast Iron				U-Shape Cast Iron	U-Shape Cast Iron	Splined	Flat Cast Iron
Hub Material	Ductile Iron or Dura-Light Hub ***				Steel	Ductile Iron	AL Splined	Aluminum
Spindle Type	HN or HP			HP	HX	HP	HN or HP	HN or HP
Lube Type	SAE 80/90 Synthetic 75W/90 Semi-Fluid Grease	SAE 80W/90 Or Synthetic 75W/90	Semi-Fluid Grease		Semi-Fluid Grease	Synthetic 75W/90 or Semi-Fluid Grease		
Spindle Nut	3 Piece Nut	PRECISION240® or PRECISION320®		PRECISION320	PRECISION320	3 Piece Nut		
Options	TIREMAAX® CP, TIREMAAX PRO or TIREMAAX PRO-LB				TIREMAAX PRO or TIREMAAX PRO-LB	TIREMAAX CP, TIREMAAX PRO or TIREMAAX PRO-LB		
* Hendrickson offers a minimum one-year, standard service wheel-end system on all ADB packages								
** WABCO PAN19 is not available with HXL7® wheel-end package								
*** Dura-Light Hub is only available with MAXX22T								

NOTE: All long-life packages do not include wearable items such as rotors and brake pads. If service to these items is necessary within the warranty period and would require removal of the hub cap (i.e. rotor replacement), Hendrickson must be notified prior to initiation of the service. If service is performed to Hendrickson’s specifications, Hendrickson will continue to warrant the system for the remainder of the original warranty period.



AIR DISC BRAKE WARRANTY

Hendrickson MAXX22T™ air disc brake packages installed by Hendrickson will carry a limited five-year parts and one-year labor warranty, excluding all normal wear. Other air disc brake packages installed by Hendrickson will carry a limited one-year parts and labor warranty, excluding all normal wear.

The wheel-end warranties for ADB cover the hub seal, bearings and hubcaps.

For complete information on Hendrickson warranty policies, refer to literature number, L583 – Hendrickson Comprehensive Warranty Statement available online at www.hendrickson-intl.com.

NOTE: Warranty coverage from our air disc brake suppliers is subject to change without notice. Always contact the air disc brake supplier for the most current warranty information and specific details regarding coverage of air disc brake parts.

AIR DISC BRAKE PACKAGE WEIGHTS COMPARED TO DRUM BRAKES

ADB package weights have closed the gap on drum brake package weights. The following tables show how several Hendrickson ADB packages compare to 16.5" x 7" and 16.5" x 8-5/8" drum brake packages. The results are listed as the difference in weight (lbs./axle).

As shown with an AANT integrated suspension system, several ADB packages are lighter than drum brakes. The lightest ADB package using Dura-Light hubs/cast rotors is nearly identical (2 lbs/axle) to the lightest 16.5" x 7" drum brake with Dura-Light hubs and Stemco CentriFuse brake drums. This analysis assumes 10-stud, 11.25" BC hubs using long studs for aluminum wheels.

QUESTIONS

For questions regarding air disc brake packages at Hendrickson, please notify your trailer account manager or call 1-866-RIDE-AIR (866-743-3247) and ask to speak with a customer or technical service representative.

INTRAAX® AIR DISC BRAKES vs. DRUM BRAKE WEIGHT COMPARISONS – AANT									
	Hendrickson MAXX22T™			Wabco PAN 22-1		Bendix ADB22X-LT			Haldex ModuIT
Option	Standard		Light-weight	Standard	Lightweight	Standard	Lightweight		Standard
Rotor Style	U-Shape		U-Shape	U-Shape	Flat	U-Shape	Flat	Splined	U-Shape
Rotor Mounting	Outboard Mount	Inboard Mount	Inboard Mount	Inboard Mount		Inboard Mount			Inboard Mount
Hub Material	Steel	Ductile Iron	Dura-Light	Ductile Iron	Aluminum	Ductile Iron	Aluminum		Ductile Iron
Hub Brand	Hendrickson		Walther	Hendrickson	ConMet PreSet	ConMet	ConMet PreSet		Hendrickson
Seal	Hendrickson				ConMet Seal	Hendrickson	ConMet Seal		Hendrickson
Bearings	Timken	Standard Bearings			ConMet Bearings	Standard Bearings	ConMet Bearings		Standard Bearings
Weight Comparison*									
16.5" x 7" Ductile Iron	(40)	(40)	(60)	25	(28)	(20)	(60)	(75)	0
16.5" x 7" Dura-Light	24	24	4	88	36	43	3	(12)	63
16.5" x 7" Aluminum	13	13	(7)	77	25	33	(8)	(23)	52
16.5" x 8 5/8" Ductile Iron	(75)	(75)	(94)	(10)	(62)	(55)	(95)	(111)	(35)
16.5" x 8 5/8" Lightweight	(24)	(24)	(43)	41	(12)	(4)	(44)	(59)	16
(BOLD) indicates the ADB package is lighter than the drum brake									
* Actual weights may vary depending on suspension selection specification									

NOTE: Due to configurations that are required to package air disc brakes on AANL suspensions, such as rear mounted shocks, the weight savings for AANL air disc brakes are not as significant as on other suspension types. Estimated weight differences for AANL drum and disc suspensions are show in the table on page 10.



INTRAAX® AIR DISC BRAKES vs. DRUM BRAKE WEIGHT COMPARISONS – AANL										
Option	Hendrickson MAXX22T™		Wabco PAN 22-1		Bendix ADB22X-LT™			Haldex ModulT		
	Standard		Lightweight	Standard	Lightweight	Standard	Lightweight		Standard	
Rotor Style	U-Shape		U-Shape	U-Shape	Flat		U-Shape	Flat	Splined	U-Shape
Rotor Mounting	Outboard Mount	Inboard Mount	Inboard Mount	Inboard Mount		Inboard Mount			Inboard Mount	
Hub Material	Steel	Ductile Iron	Dura-Light	Ductile Iron	Aluminum	Ductile Iron	Aluminum		Ductile Iron	
Hub Brand	Hendrickson		Walther EMC	Hendrickson	ConMet PreSet	ConMet	ConMet PreSet		Hendrickson	
Seal	Hendrickson				ConMet Seal	Hendrickson	ConMet Seal		Hendrickson	
Bearings	Timken	Standard Bearings			ConMet Bearings	Standard Bearings	ConMet Bearings		Standard Bearings	
Weight Comparison*										
16.5" × 7" Ductile Iron	10	10	(10)	70	18	27	(13)	(30)	46	
16.5" × 7" Dura-Light	74	74	53	134	82	91	50	34	109	
16.5" × 7" Aluminum	68	68	47	128	76	85	46	28	104	
16.5" × 8 ⁵ / ₈ " Ductile Iron	(24)	(24)	(45)	36	(16)	(7)	(48)	(64)	11	
16.5" × 8 ⁵ / ₈ " Lightweight	32	32	11	91	40	48	8	(9)	67	
(BOLD) indicates the ADB package is lighter than the drum brake										
* Actual weights may vary depending on suspension selection specification										



NOTES:

*Actual product performance may vary depending upon vehicle configuration, operation, service and other factors.
All applications must comply with applicable Hendrickson specifications and must be approved by the respective vehicle manufacturer with the vehicle in its original, as-built configuration.
Contact Hendrickson for additional details regarding specifications, applications, capacities, and operation, service and maintenance instructions.*

Call Hendrickson at 330.489.0045 or 866.RIDEAIR (743.3247) for additional information.



www.hendrickson-intl.com

TRAILER COMMERCIAL VEHICLE SYSTEMS

2070 Industrial Place SE
Canton, OH 44707-2641 USA
866.RIDEAIR (743.3247)
Fax 800.696.4416

Hendrickson Canada ULC

2825 Argentia Road, Unit #2 - 4
Mississauga, ON Canada L5N 8G6
800.668.5360
905.789.1030 • Fax 905.812.9423

Hendrickson Mexicana

Circuito El Marqués Sur #29
Parque Industrial El Marqués
Pob. El Colorado, Municipio El Marqués,
Querétaro, México C.P. 76246
+52 (442) 296.3600 • Fax +52 (442) 296.3601

L1225 Rev I 10-22

© 2014 - 2022 Hendrickson USA, L.L.C. All Rights Reserved. All trademarks shown are owned by Hendrickson USA, L.L.C., or one of its affiliates, in one or more countries.
Information contained in this literature was accurate at the time of publication. Product changes may have been made after the copyright date that are not reflected.

Printed in United States of America