

TECHNICAL PROCEDURE

Compliant, Heavy-Duty Compliant & Round-Tube Tie Rods

SUBJECT: Auxiliary Axle Tie Rod Toe Inspection
& Toe Setting Procedure

LIT NO: H785

DATE: December 2024

REVISION: D

INTRODUCTION

This publication is intended to assist maintenance personnel with toe inspection and toe setting for (1) the Compliant Tie Rod (CTR), (2) the Heavy-Duty Compliant Tie Rod (HD-CTR), or (3) the standard round-tube tie rod equipped on various Hendrickson auxiliary lift axle suspension models.

The following field inspections and service are required to ensure the proper performance of vehicles equipped with such Hendrickson auxiliary lift axle suspensions. Ensure that your vehicle is properly set up for service work and that safety procedures are adhered to during service.

CAUTION

A TECHNICIAN USING A SERVICE PROCEDURE OR TOOL WHICH HAS NOT BEEN RECOMMENDED BY HENDRICKSON MUST FIRST SATISFY HIMSELF THAT NEITHER HIS SAFETY NOR THE VEHICLE'S SAFETY WILL BE JEOPARDIZED BY THE METHOD OR TOOL SELECTED. INDIVIDUALS DEVIATING IN ANY MANNER FROM THE INSTRUCTIONS PROVIDED WILL ASSUME ALL RISKS OF CONSEQUENTIAL PERSONAL INJURY OR DAMAGE TO EQUIPMENT INVOLVED.

WARNING

IMPROPER JACKING METHOD CAN CAUSE STRUCTURAL DAMAGE AND RESULT IN LOSS OF VEHICLE CONTROL, SEVERE PERSONAL INJURY OR DEATH. DO NOT USE AXLE BEAM OUTBOARD OF AXLE SPRING SEATS FOR JACKING PURPOSES. REFER TO VEHICLE MANUFACTURER FOR PROPER JACKING INSTRUCTIONS.

YOU WILL NEED:

- Well sockets and box / open ended wrenches – 1 1/8" and 1 5/16" deep
- Torque wrench capable of – 500 ft-lbs and 60 ft-lbs
- 1/2" or 3/4" impact or pneumatic impact gun
- Can of paint, jack stands, tape measure, screwdriver
- Optional – Trammel bar

DEFINITIONS

Toe: the relationship of the distance between the front of the tires and the distance between the rear of the tires on the same self-steerable auxiliary lift axle suspension, as measured at spindle height

Toe-in: when the front toe distance is less than the rear toe distance, the wheels are in a "toe-in" condition, also known as the positive condition

Steer Ahead: the general steer angle orientation of the auxiliary lift axle wheels relative to the vehicle once the vehicle is driven in a straight line and the auxiliary lift axle is lifted, at which point the axle tires should remain approximately parallel to the vehicle

INSPECTION

The following field inspections and adjustments are necessary to ensure the proper performance of vehicles equipped with a Hendrickson self-steer auxiliary lift axle suspension.

NOTE

It is important that these procedures are conducted on flat and level surface / ground.

STEER AHEAD INSPECTION

WARNING

LOWER THE AUXILIARY LIFT AXLE ON A LEVEL FLOOR AND CHOCK THE WHEELS ON THE AXLES OTHER THAN THE AUXILIARY AXLE TO HELP PREVENT THE VEHICLE FROM MOVING. NEVER WORK UNDER A RAISED AXLE SUPPORTED BY ONLY A FLOOR JACK, WHICH CAN SLIP OR FALL OVER AND RESULT IN SERIOUS PERSONAL INJURY. ALWAYS SUPPORT A RAISED AUXILIARY AXLE WITH SAFETY STANDS.

1. On a level surface, lower the auxiliary axle onto the ground with the ride air springs set to the recommended operating pressure.

SERVICE HINT

For recommended ride air spring operating pressures and related information, see the air pressure load charts included in (1) the pre-installation literature packet provided by Hendrickson and / or (2) Hendrickson's Owner's Manual for Steerable Auxiliary Axle Systems, Literature No. OM-H754.

2. Drive the vehicle two (2) to five (5) feet straight ahead, ensuring the auxiliary axle is on a straight forward path.
3. Allow vehicle to roll to a stop (do not apply service brakes), set parking brakes.
4. Turn engine off and chock the wheels on the axles other than the auxiliary axle.
5. Raise the auxiliary axle.

6. On both the left and right hand side of the auxiliary axle, measure the **distance from outboard bolt head of the stabilizer to inboard bolt head of the stabilizer** (see Figure 1).

- a. If the two measurements are not within $\frac{1}{2}$ " of each other, it will be necessary to reset the Steer Ahead, see Steer Ahead Reset instructions in this publication.

FIGURE 1

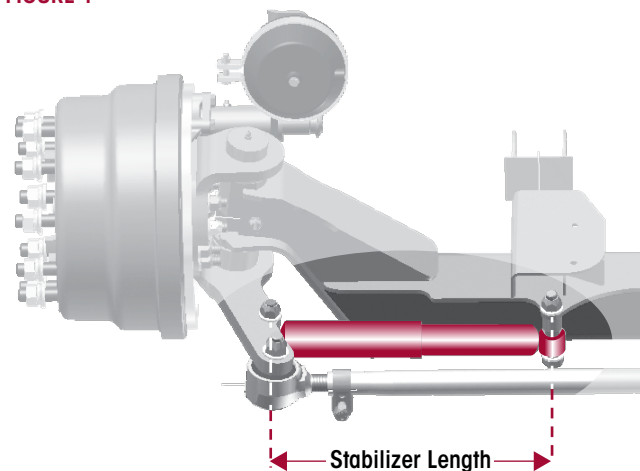

SERVICE HINT

An axle with the standard round tube tapered tie rod requires the coil-over stabilizers to be replaced if a steer ahead reset is necessary.

STEER AHEAD RESET

- Only applicable for the Compliant Tie Rods (CTR) and Heavy-duty Compliant Tie Rods (HD-CTR), not applicable for the Standard Round Tube Tie Rods.

1. On a level surface, raise the auxiliary axle.
2. Loosen, **DO NOT** remove, the tie rod end bolts on both ends of the tie rod until the bolts are free to rotate on the knuckles (see Figure 2).



3. Lower the auxiliary axle onto the ground with the ride air springs set to the recommended operating pressure.

SERVICE HINT

For recommended ride air spring operating pressures and related information, see the air pressure load charts included in (1) the pre-installation literature packet provided by Hendrickson and/or (2) Hendrickson's Owner's Manual for Steerable Auxiliary Axle Systems (Literature No. OM-H754).

4. Drive the vehicle two (2) to five (5) feet straight ahead, ensuring the auxiliary axle is on a straight forward path.
5. Allow vehicle to roll to a stop (do not apply service brakes), set parking brakes.
6. Turn engine off and chock the wheels on the axles other than the auxiliary axle.
7. Tighten the CTR or HD-CTR tie rod end bolts to  350-450 ft-lbs.
8. Raise the auxiliary axle.
9. On both the left and right hand side of the auxiliary axle, measure the **distance from outboard bolt head of the stabilizer to inboard bolt head of the stabilizer** (see Figure 1).
 - a. If the two measurements are not within 1/2" of each other, it will be necessary to repeat the Steer Ahead Reset procedure.
10. After the recommended steer ahead specification is achieved, proceed to Toe Inspection Procedure and, if necessary, Toe Setting Procedure.

FIGURE 2



TOE INSPECTION

1. Ensure the vehicle is on flat level surface.
2. Lower the auxiliary axle onto the ground with the ride air springs set to the recommended operating pressure.

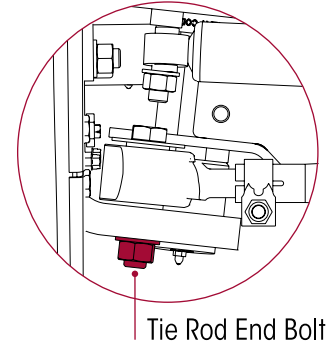
SERVICE HINT

For recommended ride air spring operating pressures and related information, see the air pressure load charts included in (1) the pre-installation literature packet provided by Hendrickson and / or (2) Hendrickson's Owner's Manual for Steerable Auxiliary Axle Systems, Literature No. OM-H754.

3. Set wheels in straight ahead position by pulling vehicle straight ahead two (2) to five (5) feet.
4. Allow vehicle to roll to a stop (do not apply service brakes), set parking brakes.
5. Turn engine off and chock the wheels on the axles other than the auxiliary axle.
6. Raise the auxiliary axle.
7. Use paint and mark the center area of tread on both tires of the auxiliary axle around the complete outer diameter of the tires (see Figure 3).
8. Using a screwdriver and jack stands, scribe a line in the wet paint around the complete circumference of both tires. Spin the tires completely during both the painting and aligning process for a consistent reference during the toe setting procedure.
9. With the ride air springs set to the recommended operating pressure, lower the auxiliary axle onto the ground. Reference the load scale stickers provided in the literature packet from Hendrickson for the recommended operating pressure.
10. **MEASURE TOE** – use a tape measure or trammel bar to achieve 1/16" to 1/8" toe-in by measuring the distance from the centerline of one scribed tire to the centerline of opposing scribed tire at the rear of the auxiliary axle (see Figure 3). Repeat the measurement at the front of the auxiliary axle.

- If the auxiliary axle does not meet Hendrickson's recommended $\frac{1}{16}$ " to $\frac{1}{8}$ " toe-in specification as shown in Figure 3, proceed to Toe Setting Procedure.

FIGURE 3 (Shown HD-CTR):

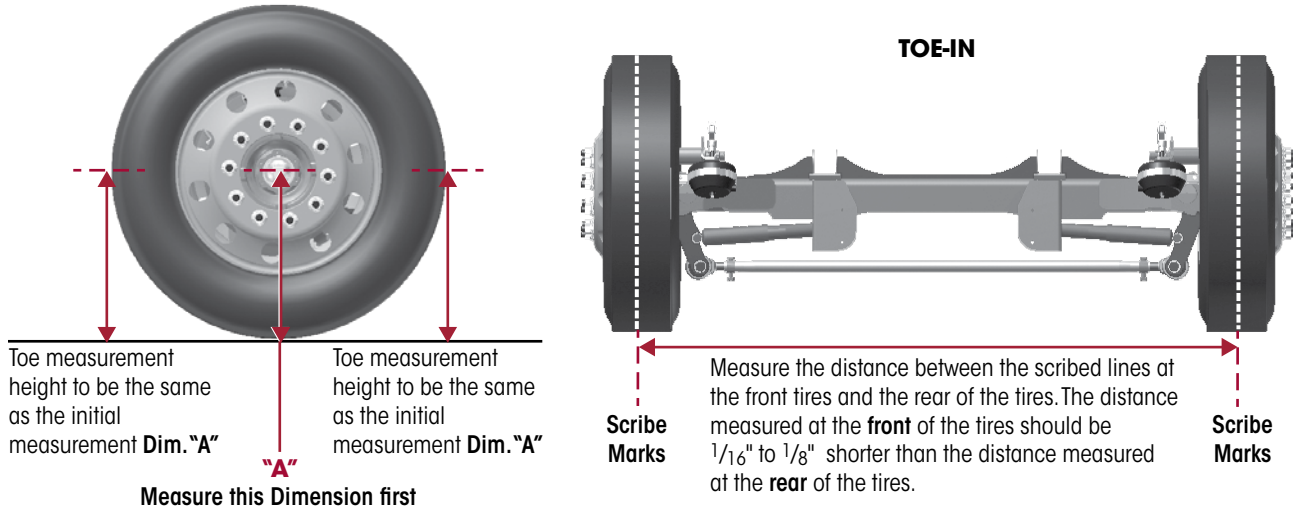

TOE SETTING

■ COMPLIANT TIE ROD (CTR)

- After the inspection, if a toe adjustment is necessary, loosen the retaining and serrated bolts on both ends of the tie rod (see Figure 4).

FIGURE 4

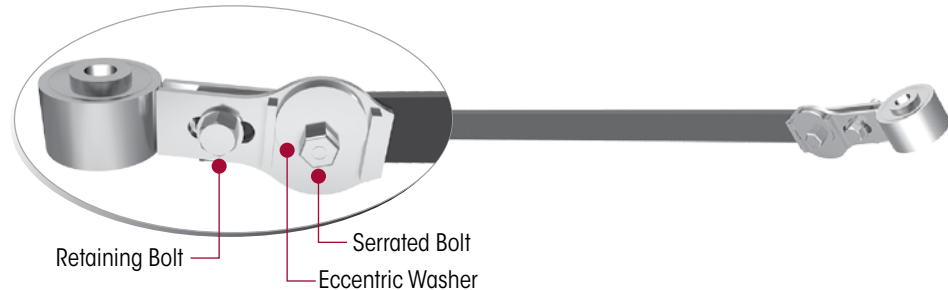

- Rotate the eccentric washer by rotating the bolt to achieve the recommended $\frac{1}{16}$ " to $\frac{1}{8}$ " toe-in specification.

NOTE

As the serrated bolt head is turned the eccentric washer with inboard grooved ridges will rotate in the same direction of the serrated bolt.

- Rotate clock-wise to **INCREASE** toe-in and counter clock-wise to **DECREASE** toe-in (see Figure 5).
- After the recommended toe specification is achieved, tighten the retaining and serrated bolts to 180-190 ft-lbs. Verify with torque wrench.
- Proceed to Final Inspection in this publication.

FIGURE 5

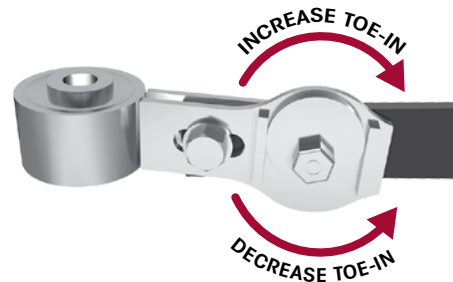



■ HEAVY-DUTY COMPLIANT TIE ROD (HD-CTR)

1. After the inspection, if a toe adjustment is necessary, loosen the tie rod clamp fasteners on both ends of the tie rod (see Figure 6).

FIGURE 6



2. Rotate the cross tube to achieve the recommended $\frac{1}{16}$ " to $\frac{1}{8}$ " toe-in specification.

SERVICE HINT

When rotating the cross tube the bushings may wind up and affect measurements. To unwind the bushings, rotate the cross tube forward and backward until the wind up releases.

3. After the recommended toe-in specification is achieved, tighten the tie rod clamp bolts to  40-60 ft-lbs. Verify with torque wrench.
4. Proceed to Final Inspection in this publication.

■ STANDARD ROUND-TUBE TIE ROD

1. After the inspection, if a toe adjustment is necessary, loosen the tie rod clamp fasteners on both ends (see Figure 7).

FIGURE 7



2. Rotate the cross tube to achieve the recommended $\frac{1}{16}$ " to $\frac{1}{8}$ " toe-in specification.
3. After the recommended toe-in specification is achieved, tighten the tie rod clamp bolts to  40-60 ft-lbs. Verify with torque wrench.
4. Proceed to Final Inspection in this publication.

FINAL INSPECTION

1. Ensure the vehicle is on flat level surface.
2. Lower the auxiliary axle onto the ground with the ride air springs set to the recommended operating pressure. Reference the load scale stickers provided in the literature packet from Hendrickson for the recommended operating pressure.
3. Set wheels in straight ahead position by pulling vehicle straight ahead two (2) to five (5) feet.
4. Allow vehicle to roll to a stop (do not apply service brakes), set parking brakes.
5. Turn engine off and chock the wheels on the axles other than the auxiliary axle.
6. Raise the auxiliary axle.
7. **MEASURE TOE** – use a tape measure or trammel bar to achieve $\frac{1}{16}$ " to $\frac{1}{8}$ " toe-in by measuring the distance from the centerline of one scribed tire to the centerline of opposing scribed tire at the rear of the axle. Repeat the measurement at the front of the axle.
 - a. If the auxiliary axle does not meet the recommended $\frac{1}{16}$ " to $\frac{1}{8}$ " toe-in, the toe setting procedure must be repeated.
8. It is the responsibility of the installer to ensure the toe is correct prior to the vehicle entering service.

*Actual product performance may vary depending upon vehicle configuration, operation, service and other factors.
All applications must comply with applicable Hendrickson specifications and must be approved by the respective vehicle manufacturer with the vehicle in its original, as-built configuration.
Contact Hendrickson for additional details regarding specifications, applications, capacities, and operation, service and maintenance instructions.*

Call Hendrickson at 800.660.2829 or 800.668.5360 in Canada for additional information.



www.hendrickson-intl.com

**SPECIALTY PRODUCTS -
AUXILIARY AXLE SYSTEMS**

277 North High Street
Hebron, OH 43025 USA
800.660.2829
740.929.5600 • Fax 740.929.5601

Hendrickson Canada ULC

2825 Argentia Road, Unit #1 - 4
Mississauga, ON Canada L5N 8G6
800.668.5360
905.789.1030 • Fax 905.812.9423

H785 Rev D 12-24

© 2019 — 2024 Hendrickson USA, L.L.C. All Rights Reserved. All trademarks shown are owned by Hendrickson USA, L.L.C., or one of its affiliates, in one or more countries.
Information contained in this literature was accurate at the time of publication. Product changes may have been made after the copyright date that are not reflected.

Printed in United States of America