

HAULMAAX[®] EX

Heavy-Duty, Lightweight Rear Drive Axle, Rubber Suspension System for Peterbilt Trucks

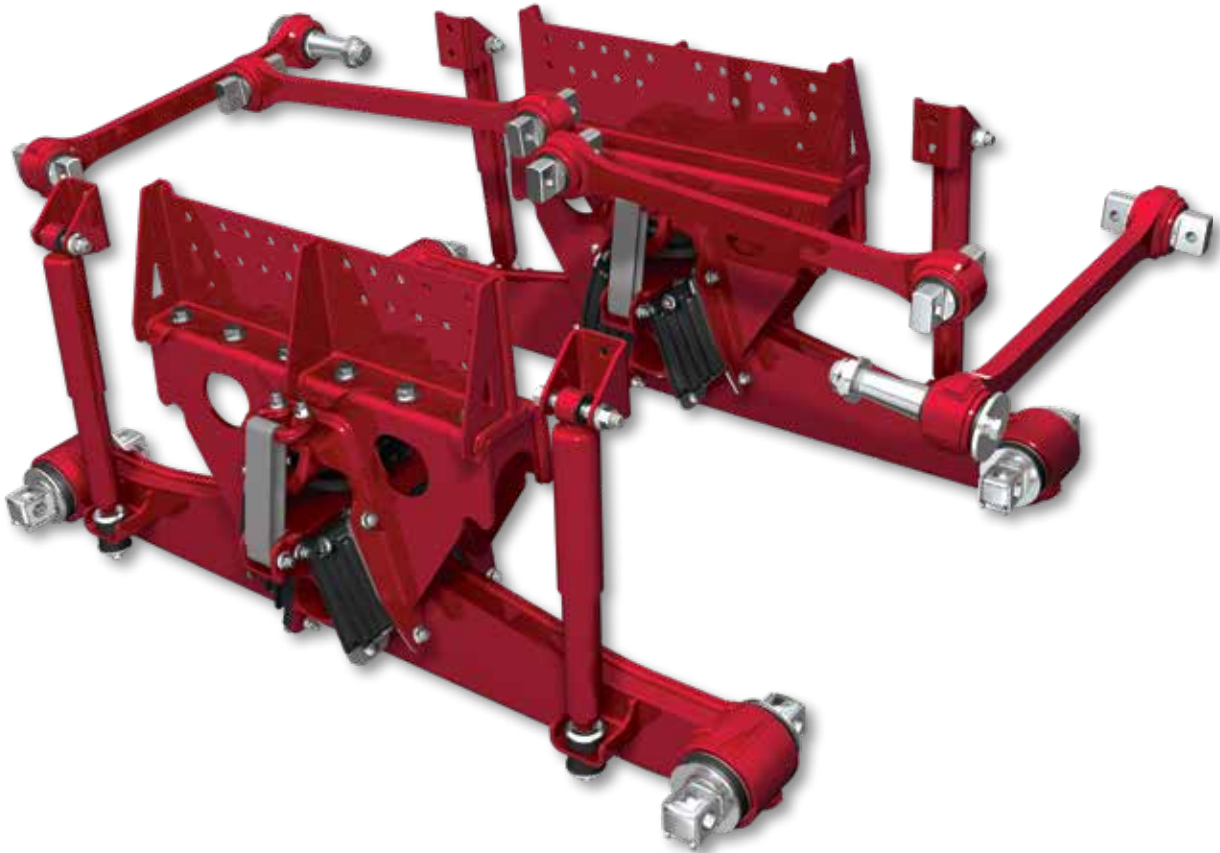

- MAAximize payload
- MAAximize performance
- MAAximize durability



Suspension geometry is optimized to provide better site rating, increased capacity ranges and improved durability. Utilizing industry leading validation techniques, high-strength materials, and advanced manufacturing methods, HAULMAAX[®] EX meets the increasingly rigorous application demands by delivering the reliability and quality you've come to expect from Hendrickson, the leader in suspension technology.

HAULMAAX EX features a unique spring design that balances empty ride quality and loaded stability. Angled bolster springs and a unique progressive load spring provide exceptional stability for demanding applications such as refuse, concrete mixers and dump. HAULMAAX EX is available in capacities from 40,000 to 52,000 pounds on Peterbilt 520, 520EV, 548, 567, 579 and 589 models.



To learn more about HAULMAAX EX,
call 855.743.3733 or visit www.hendrickson-intl.com

HENDRICKSON
The World Rides On Us[®]

MAAXimize Payload • MAAXimize Mobility and Traction • MAAXimize Stability MAAXimize Driver Comfort • MAAXimize Performance

Hendrickson TRAAX ROD® Torque Rods

- Fabricated heavy-duty torque rods provide greater durability over conventional rods
- Enhance handling during cornering by controlling lateral forces to maintain axle position
- Standard on Peterbilt models in transverse torque rod position
- Optional in longitudinal torque rod position

Progressive Load Spring

- Increases stiffness as the load increases, providing a unique balance of empty ride quality and loaded stability
- Provides long service life and easy replacement for reduced downtime

Dual Rebound Straps

- Provide additional bolster spring protection
- Required on vehicles equipped with outriggers
- Standard on 52,000 lb. suspensions
- Sales Code - 1921965

Premium Rubber Bolster Springs

- The unique design works with the Progressive Load Spring to deliver exceptional empty ride quality and loaded stability

Longitudinal Torque Rods

- Engineered to optimize resistance to wind up during acceleration and braking

Saddle and Frame Bracket

- Lightweight, modular design simplifies installation
- Available in saddle heights of 15.5" (Sales Code - 1921365), 16.5" (1921375) and 17.5" (1921695)

Bar Pin End Connection

- Rugged axle connection helps extend bushing life and allows easy axle alignment and serviceability

Equalizing Beam

- Distributes load equally between both axles for improved traction
- Lowers the center of gravity to increase stability
- Establishes a solid axle connection for improved handling
- Center bushing eliminated for reduced maintenance

Shock Absorbers

- Provide additional driver comfort
- Required for tractor and logging applications
- Sales Code - 1921475

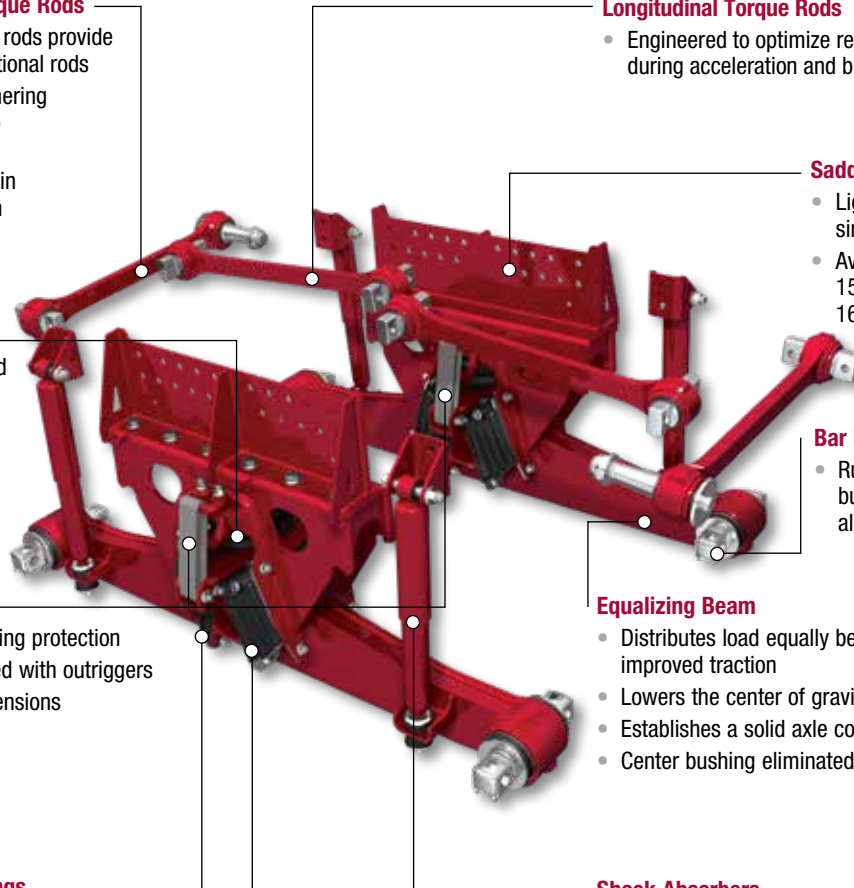

Sales Code	Description	Model					
		520	520EV	548	567	579	589
1824430	HAULMAAX EX 40,000 lb. Capacity, 52" Axle Spacing	✓	✓		✓		✓
1824400	HAULMAAX EX 40,000 lb. Capacity, 54" Axle Spacing	✓	✓	✓	✓	✓	✓
1824440	HAULMAAX EX 46,000 lb. Capacity, 52" Axle Spacing	✓	✓	✓	✓		✓
1824410	HAULMAAX EX 46,000 lb. Capacity, 54" Axle Spacing	✓	✓	✓	✓		✓
1824380	HAULMAAX EX 46,000 lb. Capacity, 60" Axle Spacing	✓	✓	✓	✓		✓
1824390	HAULMAAX EX 46,000 lb. Capacity, 72.5" Axle Spacing	✓		✓	✓		✓
1824370	HAULMAAX EX 52,000 lb. Capacity, 54" Axle Spacing	✓			✓		✓

Actual product performance may vary depending upon vehicle configuration, operation, service and other factors. All applications must comply with applicable Hendrickson specifications and must be approved by the respective vehicle manufacturer with the vehicle in its original, as-built configuration. Contact Hendrickson for additional details regarding specifications, applications, capacities, operation, service and maintenance instructions.

Call Hendrickson at **630.910.2800** or **855.RIDERED (743.3733)** for additional information.



TRUCK COMMERCIAL VEHICLE SYSTEMS
800 South Frontage Road
Woodridge, IL 60517-4904 USA
855.RIDERED (743.3733)
630.910.2800 • Fax 630.910.2899



www.hendrickson-intl.com

www.peterbilt.com