

COMFORT AIR®

Rear Drive Axle Air Suspension System for Hino Trucks



- Superior comfort
- Outstanding ride
- Improves handling
- Reduces maintenance



To learn more about COMFORT AIR,
call 855.743.3733 or visit www.hendrickson-intl.com

HENDRICKSON
The World Rides On Us®

COMFORT AIR® for Hino Trucks

Reduced Maintenance

- Wide footprint of frame hanger bracket distributes load over a larger area, reducing stress to the frame to help increase the life of the vehicle
- Durable pivot bushing connection provides quiet operation and helps extend suspension service life

Height Control Valve

- Fast acting HCV maintains precise ride height control through changing road surfaces, loads and driving conditions

Stability and Handling

- Durable ULTRA-ROD® torque rod enhances handling during cornering by controlling lateral forces to maintain axle position

QUIK-ALIGN®

- Pivot bolt connections reduce maintenance time by offering a fast and easy method to adjust and set alignment without shims

Main Support Member

- Extended length generates lower spring rate for optimized roll stiffness, providing a more comfortable and compliant ride

Shock Absorbers

- Tuned for optimum dampening characteristics to provide maximum driving comfort

Air Springs

- Adjust to changing load conditions to deliver superior ride quality

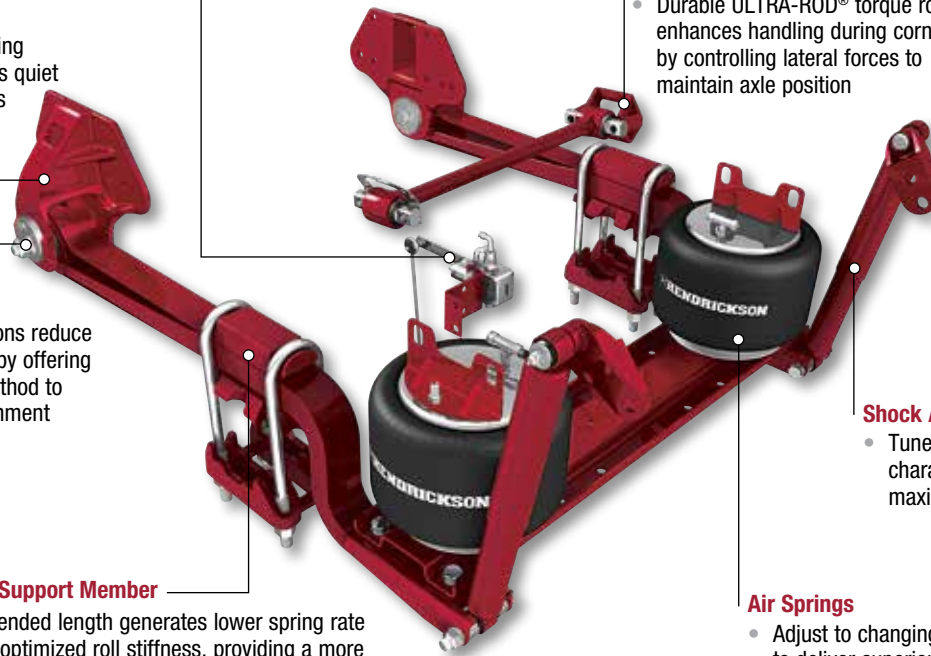

	COMFORT AIR®		
Suspension Capacity (lbs.)	19,000	21,000	23,000
Suspension Weight (lbs.)	460.5	461	530
Main Support Member	Single	Single	Double

Actual product performance may vary depending upon vehicle configuration, operation, service and other factors. All applications must comply with applicable Hendrickson specifications and must be approved by the respective vehicle manufacturer with the vehicle in its original, as-built configuration. Contact Hendrickson for additional details regarding specifications, applications, capacities, operation, service and maintenance instructions.

Call Hendrickson at **630.910.2800** or **855.RIDERED (743.3733)** for additional information.



TRUCK COMMERCIAL VEHICLE SYSTEMS
 800 South Frontage Road
 Woodridge, IL 60517-4904 USA
 855.RIDERED (743.3733)
 630.910.2800 • Fax 630.910.2899

www.hendrickson-intl.com

