

- Enhanced performance
- Lightweight design
- Fabricated construction



Hendrickson's LUXAIR® is a premium rear-drive axle air suspension ideal for transit and coach bus applications. Utilizing Hendrickson's expertise in vehicle dynamics, this suspension can package with a variety of air springs and shock absorbers to ensure optimal performance. The fabricated construction allows for flexibility, simplifying packaging for a variety of frame types and body styles. The efficient design also provides a lightweight solution that maintains the durability and performance expected in demanding transit and coach applications.

Protect What Matters...with Hendrickson



To learn more about LUXAIR,
call 866.743.3247 or visit
www.hendrickson-intl.com

H HENDRICKSON
The World Rides On Us®

LUXAIR® Features and Benefits

Adjustable Torque Rods

- Quickly adjust length to align the axle without having to use drop-in shims

TRAAX ROD® - Longitudinal Torque Rods

- Exceptional walk out performance
- Designed for durability

High Volume Air Springs

- Outstanding level of passenger comfort for inner-city, touring bus and coach applications
- Outboard mounting for superb handling and a significant reduction in road-induced shock loads

Advanced Performance

- Non-reactive to brake and drive torque
- Outboard shocks and air springs provide additional roll and stability protection

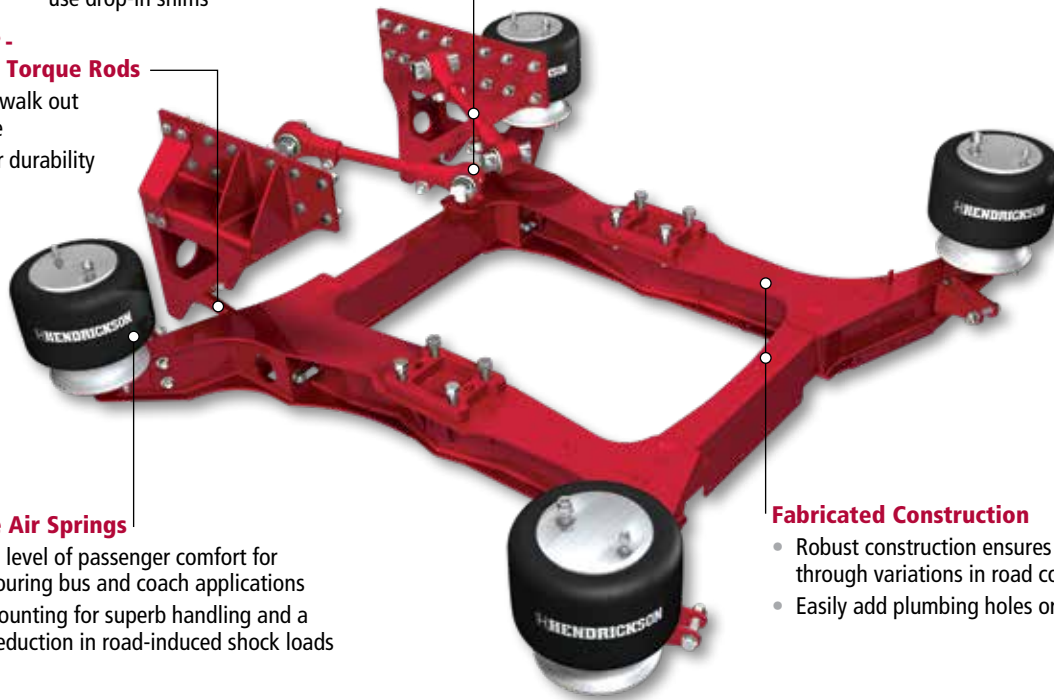

Fabricated Construction

- Robust construction ensures exceptional reliability through variations in road conditions
- Easily add plumbing holes or mounting brackets

LUXAIR Specifications

Scalable Capacity	Up to 29K
Installed Weight ¹	944 lbs.
Axle Travel ²	+2.8 in. / -3 in.
Ride Height ³	7.5 in.
Brakes	Drum or Air Disc
Engine Torque Restrictions	None

1. Installed weight includes complete suspension, torque rods and all hardware. Published weight is for LUXAIR at a 7.5 inch ride height. Other configurations may change weight. Axle brackets and frame hangers are not included.
2. Axle travel may be limited by vehicle manufacturer; axle stop settings and shock stroke may restrict suspension articulation. Varying ride heights and configurations may restrict travel. Contact Hendrickson for maximum axle travel values for LUXAIR.
3. For different ride height options, please contact Hendrickson, the vehicle manufacturer or dealer for further information.

Actual product performance may vary depending upon vehicle configuration, operation, service and other factors.

All applications must comply with applicable Hendrickson specifications and must be approved by the respective vehicle manufacturer with the vehicle in its original, as-built configuration. Contact Hendrickson for additional details regarding specifications, applications, capacities, and operation, service and maintenance instructions.

Call Hendrickson at **630.910.2800** or **855.RIDERED (743.3733)** for additional information.



www.hendrickson-intl.com

TRUCK COMMERCIAL VEHICLE SYSTEMS

800 South Frontage Road
Woodridge, IL 60517-4904 USA
855.RIDERED (743.3733)
630.910.2800 • Fax 630.910.2899

45745-539 09-21

© 2021 Hendrickson USA, L.L.C. All Rights Reserved. All trademarks shown are owned by Hendrickson USA, L.L.C., or one of its affiliates, in one or more countries. Information contained in this literature was accurate at the time of publication. Product changes may have been made after the copyright date that are not reflected.

Printed in United States of America