

H SELECTION GUIDE

One and Two-piece Torque Rods and Replacement Bushings

LIT NO: 45745-148

DATE: January 2025

REVISION: G

CONTENTS

Introduction	2	One-piece Torque Rods TRAAX ROD®	10
Torque Rod Inspection	2	One-piece Torque Rods ULTRA ROD®	12
Transverse Torque Rods	3	Torque Rod Bushings	20
Two-piece Torque Rods	5	Torque Rod Brackets	23

XTRB™ Bushing

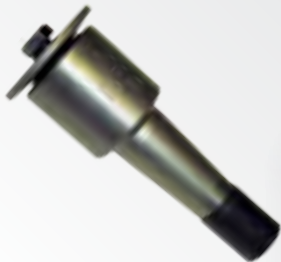

**ULTRA ROD®
Two-piece Torque Rod**

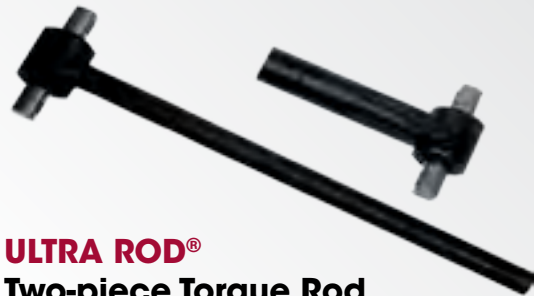

**TRAAX ROD®
Torque Rod**

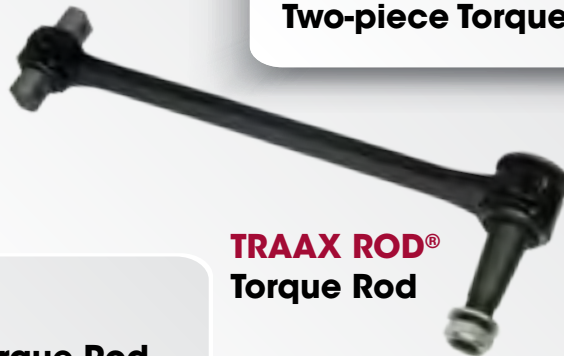

**ULTRA ROD®
One-piece Torque Rod**

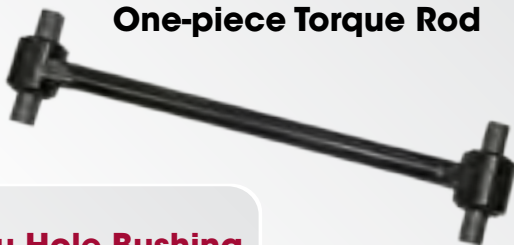

Thru Hole Bushing



**Conventional
Bushing**



Bonded Bushing



To learn more about Hendrickson
Genuine Parts, call 1.866.755.5968 or
visit www.hendrickson-intl.com

■ Introduction

This Selection Guide is intended to aid in the proper identification of originally equipped one and two-piece torque rods and bushings for component replacement.

Prior to conducting any work, review and follow all applicable installation, preventive maintenance, service and safety instructions issued by the respective vehicle and suspension manufacturers. Refer to applicable Hendrickson Technical Literature for additional information on proper maintenance, service, repair and rebuild instructions available online at www.hendrickson-intl.com

■ Torque Rod Inspection

All torque rods need to be inspected during preventive maintenance and service for looseness by one of the following methods.

All torque rods need to be inspected for looseness by one of the following methods.

- **Method 1** — Due to visibility, this procedure is **ONLY for on-highway tractor applications**. With the brakes applied, slowly rock the empty vehicle with power while a second technician visually checks the action at both ends.
- **Method 2** — With the vehicle shut down, a lever check can be made using a long pry bar placed under each torque rod end and pressure applied.

Visually inspect **(1) torque rod bushings** for any torn or shredded rubber material interfaces or elongated oval shapes and **(2) torque rods** for any metal to metal contact, bent, cracked or broken components. The torque rod and/or the torque rod bushings will require replacement if any of these conditions are encountered.



Longitudinal and transverse **torque rod lengths** are determined by the original vehicle manufacturer for optimum drive line angle(s). The mounting brackets at the axle ends of the torque rods are generally furnished and welded into position on the axle housings by the axle manufacturer.

Whether the torque rod is equipped with **straddle, taper stud, or hollow mount bushings**, they can be replaced by pressing out the worn components and installing new Hendrickson bushings with the exception of torque rods designed with permanent bushings that are non-replaceable.

The **TRAAX ROD** bushings are non-serviceable and the entire assembly requires replacement.

It is important that the **tightening torque** of the locknuts be checked during preventive maintenance and service. Follow the tightening torque specifications and all applicable preventive maintenance, service and safety instructions issued by the respective vehicle and suspension manufacturers.

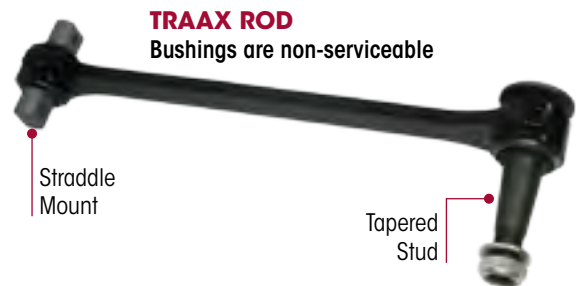

NOTE

Hendrickson Suspension recommends Grade 8 bolts, hardened flat washer and Grade C locknuts be used for all straddle mount torque rod attachments.

Hendrickson provides two-piece torque rods that are available to cut and weld to the desired length, for more information refer to the **Two-Piece Torque Rod Section** of this publication.



■ Transverse Torque Rods are...

Required for vehicles equipped with the following Hendrickson rear suspensions:

- AR2™
- COMFORT AIR®
- ROADMAAX®
- HAS™
- HAS™ 40LH
- HN®
- HN® FR
- HAULMAAX®
- HAULMAAX® EX
- PRIMAAX® EX
- FIREMAAX® EX
- ULTIMAAX®

NOTE

Transverse torque rods **ARE NOT** allowed to be used in conjunction with Hendrickson walking beam suspensions with bronze center bushings.



WHEN TRANSVERSE TORQUE RODS ARE USED ON THOSE HENDRICKSON WALKING BEAM SUSPENSIONS, EQUIPPED WITH CENTER BUSHINGS, EACH EQUALIZING BEAM MUST USE A RUBBER CENTER BUSHING. EQUALIZING BEAMS THAT CONTAIN A BRONZE CENTER BUSHING MUST BE CONVERTED TO A RUBBER CENTER BUSHING PRIOR TO INSTALLING TRANSVERSE TORQUE RODS. FAILURE TO DO SO CAN CAUSE PREMATURE COMPONENT WEAR AND/OR ADVERSE VEHICLE HANDLING.

Also required for vehicles equipped with the following Hendrickson equalizing (walking) beam suspensions with rubber center bushings.

		EQUALIZING BEAM LENGTH	
Suspension	Capacity	Less than 60"	60" and longer
R • RS • RT • RTE	34K	★	Required
	40K	★	
	44K – 52K	Required	
R • RS • RT	65K	★	
RT	70K	Required	
ULTIMAAX	46K – 63K	Required	
Suspension	Capacity	64" and Less	Longer than 64"
R • RS	85K – 120K	★	Required

★ Transverse torque rods **ARE REQUIRED** in all refuse, mining, and logging applications, and available for vehicles in other applications also.

RECOMMENDED where it is necessary to restrict the lateral movement of the axles to prevent interference of the tires, brakes, axle housings, etc. with the frame, body, or suspension components. The proper clearance is determined by the vehicle manufacturer prior to vehicle assembly.

Installation | Recommended Guidelines

NOTE

Hendrickson recommends the use of Grade 8 bolts, Grade C locknuts and hardened washers for all transverse torque rod attachments.

- With the vehicle at loaded ride height, the transverse torque rod horizontal centerline has an angle of $90^\circ \pm 2.5^\circ$ to the frame, see Figure 1.
- The transverse torque rod frame brackets are mounted to the frame and located as close as possible to either the bottom frame flange (preferably) or top frame flange, see Figure 1.
- Frame backup plates are required (may be supplied by the vehicle manufacturer) with transverse torque rod frame brackets, see Figure 1.

FIGURE 1

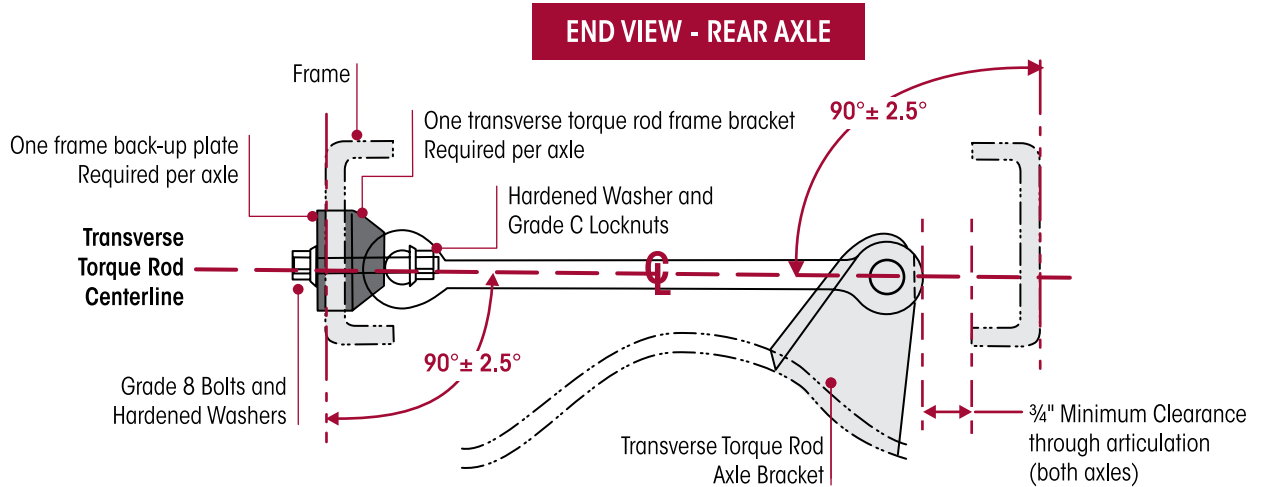
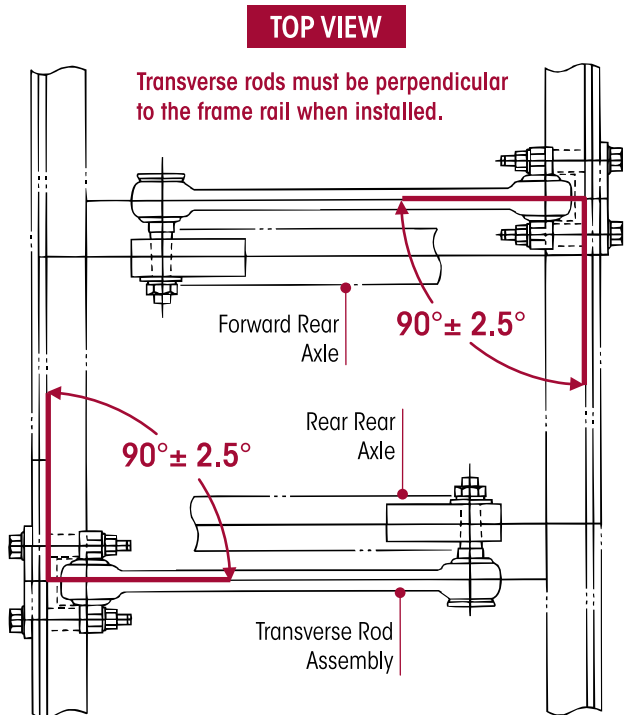

FIGURE 2

- Transverse torque rods should be positioned as low as possible to the horizontal center-line of the axle, but high enough as not to interfere with axle components during articulation.
- Install transverse torque rods perpendicular to the frame rails ($90^\circ \pm 2.5^\circ$), see Figure 2.

NOTE

A vehicle equipped with transverse torque rods may experience some reduction in suspension articulation or increased lateral stiffness and resistance to turning, especially with radial ply tires.





Two-piece Torque Rods | Instructions

Two-piece torque rods are an excellent replacement option for one-piece torque rods for both the on-highway and vocational applications. They are designed for up to 27 inch centers for most applications and 35 inch for widespread tandem.

Two-piece Torque Rods | How to Measure

Due to variances in straddle pin thickness amongst Hendrickson torque rods and various manufacturers, it is important to measure to determine the proper torque rod length. On the torque rod assembly being replaced, if there is:

- No damage to the existing torque rod body where measurement is not affected, first verify how the torque rod is mounted and then calculate the proper torque rod length measurement and make the new torque rod the same length, refer to Figure 3.
- Visible damage to the existing torque rod body, (bent, cracked or broken) it will be necessary to measure the physical dimensions on the vehicle to determine the proper length.

FIGURE 3

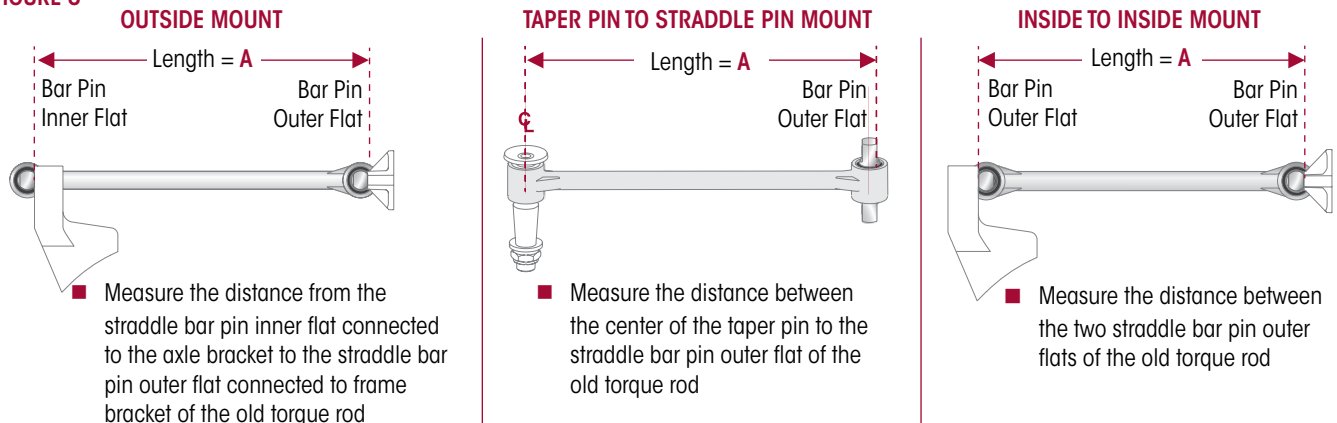

Pre-assembly | Metal Preparation

1. Identify the proper torque rod mount currently on your vehicle (see Dimension A in Figure 3).
2. Assemble the male spacer end into the base of the female tube end until it bottoms out. Measure for excess, see Figure 4.

FIGURE 4

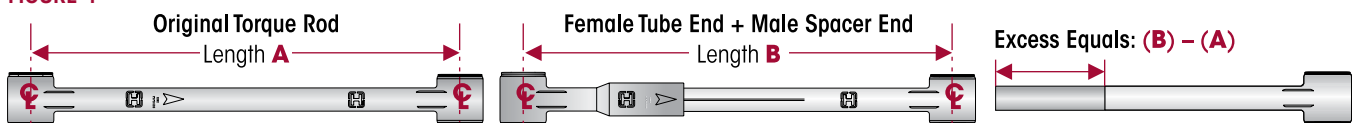

BE SURE TO WEAR PROPER EYE AND HEARING PROTECTION, AND WEAR THE PROPER PERSONAL CLOTHING PROTECTION WHEN PERFORMING STEPS 3 AND 4.

3. Remove the excess material (as shown in Figure 4) from the male spacer end using an abrasive cutting or sawing method. End face of the male spacer end should be cut square. **DO NOT** use flame or arc cut methods.
4. Remove all grease, oil, rust, or oxides from the metal surfaces to be welded by grinding, filing or power brushing.

NOTE

Refer to Hendrickson Technical Publications 59310-002 (ULTRA ROD) and 59310-024 (ULTRA ROD PLUS) for welding instructions, available online at www.hendrickson-intl.com.



Two-piece Torque Rods | KITS

ULTRA ROD®, **ULTRA ROD® PLUS™** and **XTRB™** two-piece kits contain spacer and tube ends with bushings in one convenient box. For dimension information of individual torque rod ends, refer to Pages 7-9.

ULTRA ROD				
Kit Number	Tube End		Spacer End	
	Part No.	End Type	Part No.	End Type
60214-000	66610-000H	Straddle	66671-000H	Taper
60215-000	66610-000H	Straddle	66681-000H	Taper
60216-000	66620-000H	Taper	66671-000H	Taper
60217-000	66610-000H	Straddle	66701-000H	Thru Bolt
60218-000	66610-000H	Straddle	66661-000H	Straddle
60219-000	66630-000H	Taper	66681-000H	Taper
60220-000	66610-000H	Straddle	66691-000H	Taper
60221-000	66640-000H	Offset Straddle	66701-000H	Thru Bolt
60222-000	66650-000H	Thru Bolt	66701-000H	Thru Bolt
60223-000	66610-000H	Straddle	66660-000H	Straddle
60224-000	66610-000H	Straddle	66680-000H	Taper
60226-000	66610-000H	Straddle	66670-000H	Taper
60227-000	66610-000H	Straddle	66690-000H	Taper
60228-000	66640-000H	Offset Straddle	66700-000H	Thru Bolt
60229-000	66650-000H	Thru Bolt	66700-000H	Thru Bolt
60230-000	66767-000H	Straddle	66681-000H	Taper
60231-000	66767-000H	Straddle	66680-000H	Taper
60232-000	66767-000H	Straddle	67047-000H	Straddle
60233-000	66767-000H	Straddle	67046-000H	Straddle

ULTRA ROD PLUS				
Kit Number	Tube End		Spacer End	
	Part No.	End Type	Part No.	End Type
65781-000	46610-001	Straddle	46681-001	Taper
65781-003	46610-001	Straddle	46661-001	Straddle

Two-piece ULTRA ROD PLUS Torque Rod Kits Includes torque rod frame bracket, axle bracket, spacer plates and 5/8" fasteners.

42518-045	46610-001	Straddle	46681-001	Taper
42518-047	46610-001	Straddle	46681-001	Taper

ULTRA ROD PLUS WITH XTRB BUSHINGS				
Kit Number	Tube End		Spacer End	
	Part No.	End Type	Part No.	End Type
65781-001	46610-003	Straddle	46661-002	Straddle
65781-002	46610-003	Straddle	46681-002	Taper
65781-005	46610-004	Straddle	46661-005	Straddle



ULTRA ROD® PLUS™ Two-piece Torque Rod with XTRB™ Bushings

ULTRA ROD® Two-piece Torque Rod with Bonded Bushings

TWO-PIECE TORQUE RODS



Two-piece Torque Rods | ULTRA ROD PLUS

Empty End Hubs offer added versatility to ULTRA ROD PLUS torque rods. Empty end hubs allow the use of any **PLUS** and **XTRB** bushing configuration from existing Hendrickson torque rods. The two-piece design requires stocking only two part numbers, eliminating multiple torque rod inventory. Refer to Torque Rod Bushings Section for specific torque rod bushing information.

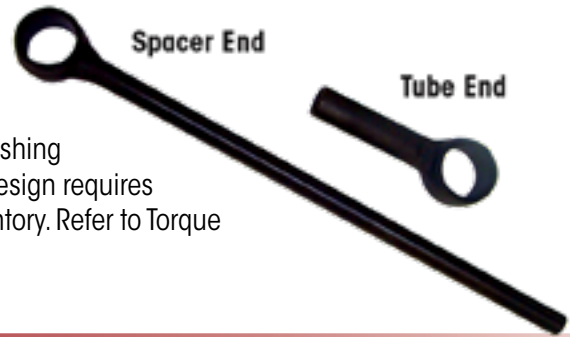

Empty End Hubs

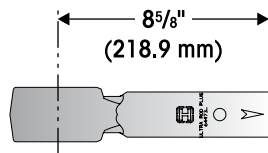

Tube End Part No. **64473-000**

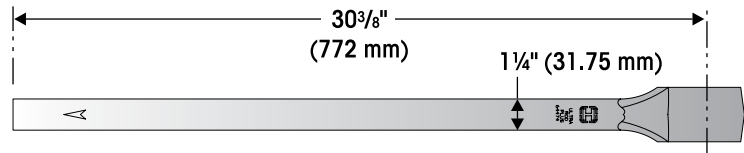

Spacer End Part No. **64474-000**

Pre-assembled with Bushings

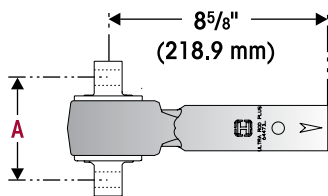

Tube End Part No.	Replacement Bushing			
	Part No.	A Mounting Center	Hole Diameter	
			mm	inch
46610-001	64400-002L	4 3/8" (111.13 mm)	16.6	5/8
46610-003	◆ 66649-002L			
46610-004	◆ 66649-005L			
* 46610-005	64400-002L			

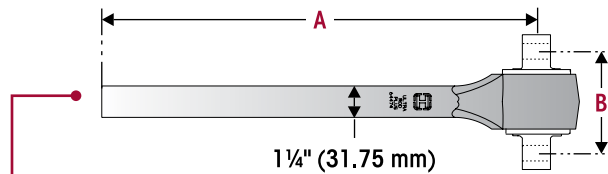

Spacer End Part No.	Torque Rod		Replacement Bushing			
	A Length		Part No.	B Mounting Center	Hole Diameter	
	mm	inch			mm	inch
46661-001H	772	30%	64400-002L	4 3/8" (111.13 mm)	16.6	5/8
46661-002H			◆ 66649-002L			
46661-005H			◆ 66649-003L	5 1/4" (133.4 mm)	23.1	1 5/16

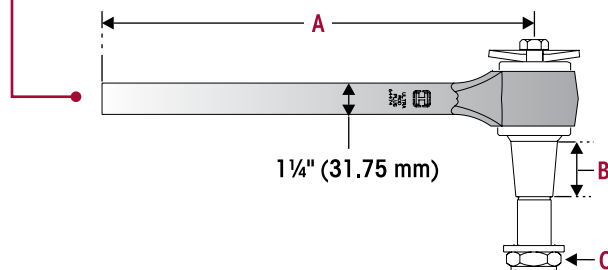

Spacer End Part No.	Torque Rod		Replacement Bushing			
	A Length		Part No.	B Taper Pin		C Thread
	mm	inch		mm	inch	inch
46681-001H	772	30%	64400-004L	73.66	2 7/8	1 1/4
46681-002H			◆ 66649-004L			

* 5° Clocking angle
◆ XTRB Bushings

TWO-PIECE TORQUE RODS



Two-piece Torque Rods | **ULTRA ROD**

TWO-PIECE TORQUE RODS

TUBE END | **SPACER END**

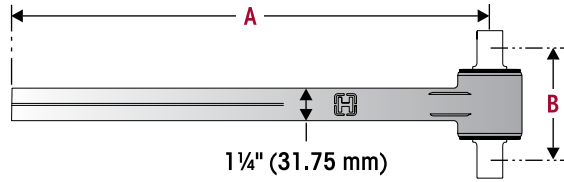
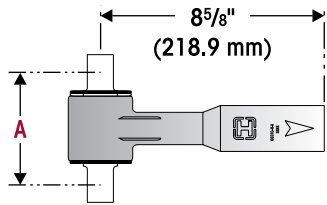

Torque Rod	Replacement Bushing			
Tube End Part No.	Part No.	A Mounting Center	Hole Diameter	
			mm	inch
66610-000H	47691-000L	4 3/8" (111.13 mm)	16.6	5/8
66767-000H	69210-000L		19.8	3/4
66766-000H	67746-000L		23	7/8

Torque Rod	Replacement Bushing					
Spacer End Part No.	A Length		B Mounting Center	Part No.	Hole Diameter	
	mm	inch			mm	inch
66661-000H	570.5	22 7/16	4 3/8" (111.13 mm)	47691-000L	16.6	5/8
67047-000H				69210-000L	19.8	3/4
67048-000H				67746-000L	23	7/8
66660-000H	770.5	30 5/16		47691-000L	16.6	5/8
67046-000H				69210-000L	19.8	3/4
66768-000H	570.5	22 7/16		5 1/16" (144 mm)	66734-000L	19.8

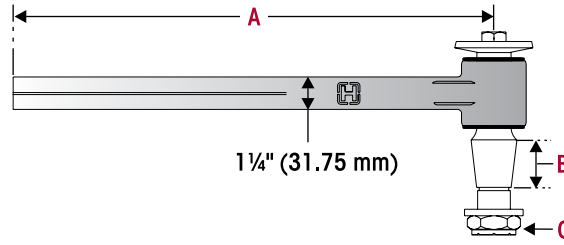
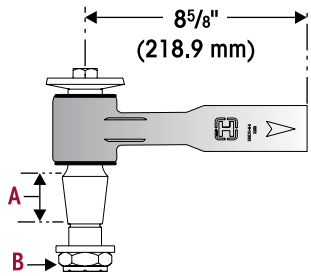

Torque Rod	Replacement Bushing			
Tube End Part No.	Part No.	A Taper Pin		B Thread
		mm	inch	inch
66769-000H	66735-000L	44	1 3/4	1 1/4
66620-000H	64809-000L	48	1 7/8	1 1/8
66630-000H	64697-000L	70	2 3/4	1 1/4

Torque Rod	Replacement Bushing					
Spacer End Part No.	A Length		Part No.	B Taper Pin		C Thread
	mm	inch		mm	inch	inch
66691-000H	570.5	22 7/16	66735-000L	44	1 3/4	1 1/4
66690-000H	770.5	30 5/16				
66671-000H	570.5	22 7/16	64809-000L	48	1 7/8	1 1/8
66670-000H	770.5	30 5/16				
66681-000H	570.5	22 7/16	64697-000L	70	2 3/4	1 1/4
66680-000H	770.5	30 5/16				



TUBE END

SPACER END

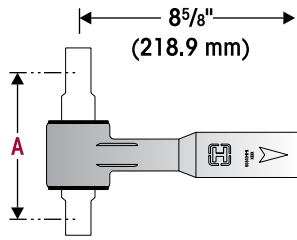

Torque Rod	Replacement Bushing			
Tube End Part No.	Part No.	A Mounting Center	Hole Diameter	
			mm	inch
66640-000H	66734-000L	5 1/16" (144 mm)	19.8	3/4

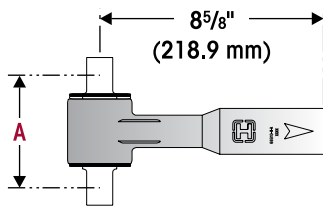

Torque Rod	Replacement Bushing			
Tube End Part No.	Part No.	A Mounting Center	Hole Diameter	
			mm	inch
66610-000H	47691-000L	4 7/8" (111.13 mm)	16.6	5/8

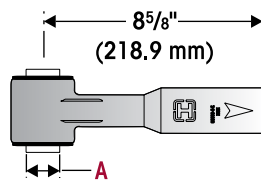

Torque Rod	Replacement Bushing	
Tube End Part No.	Part No.	A Mounting Center
66650-000H	65477-000L	1 5/16" (33.3 mm)

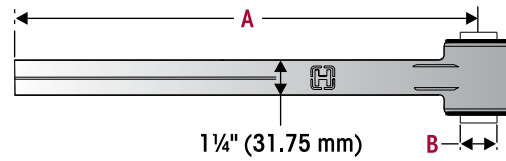

Torque Rod	Replacement Bushing		
Spacer End Part No.	A Length		B Mounting Center
	mm	inch	
66701-000H	570.5	22 7/16	65477-000L 1 5/16" (33.3 mm)
66700-000H	770.5	30 5/16	

TWO-PIECE TORQUE RODS



■ One-piece Torque Rods

Smart Numbering System | TRAAX ROD®

The TRAAX ROD®, one-piece torque rod family follows the **Smart Numbering System**, in which the digits signify the body style, bushing combination, bushing hole diameter, bushing clocking angle and the torque rod length, see illustration below.

TRAAX ROD bushings are non-serviceable, the entire torque rod assembly requires replacement. Visit www.traaxrods.com for more information

TRAAX ROD SMART NUMBERING SYSTEM

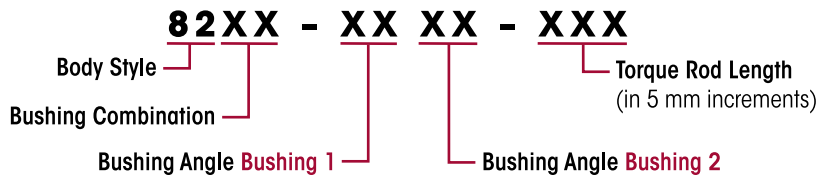

82XX - XX XX - XXX

		BUSHING COMBINATION							
		Bushing 1				Bushing 2			
		Straddle		Taper		Straddle		Taper	
		Hole Diameter	A Mounting Center	B Length	C Thread	Hole Diameter	A Mounting Center	B Length	C Thread
Heavy-duty	40	5/8"	4 3/8"	[Diagram]		5/8"	4 3/8"		
	41	3/4"	4 3/8"	[Diagram]		3/4"	4 3/8"		
	44	5/8"	4 3/8"	[Diagram]				3"	1 1/4"
	45	3/4"	4 3/8"	[Diagram]				3"	1 1/4"
Recommended for 40K to 52K pound capacity suspensions in most vocational applications.									
Severe-duty	30	5/8"	4 3/8"	[Diagram]		5/8"	4 3/8"		
	32	7/8"	5 1/4"	[Diagram]		7/8"	5 1/4"		
	33	5/8"	4 3/8"	[Diagram]				3"	1 1/4"
	35	7/8"	5 1/4"	[Diagram]				3"	1 1/4"
	36			3"	1 1/4"	[Diagram]		3"	1 1/4"
Recommended for 60K to 70K pound capacity suspensions or 40K to 52K pound capacity suspensions for even longer service intervals.									

ONE-PIECE TORQUE RODS



82XX-XX XX-XXX

BUSHING ANGLE¹

(-)° (+)° Bushing Angle ± 2° Degree



Code	Degree ²	Code	Degree ²	Code	Degree ²
00	00°	07	35°	55	-25°
01	05°	08	40°	56	-30°
02	10°	09	45°	57	-35°
03	15°	51	-5°	58	-40°
04	20°	52	-10°	59	-45°
05	25°	53	-15°	98	Taper Up ³
06	30°	54	-20°	99	Taper Down

1. Contact Hendrickson for additional bushing angles.
2. Clocking angle is ± 2° degrees.
3. Taper up bushing angle available only for 8236 series.

82XX-XX XX-XXX

TORQUE ROD LENGTH

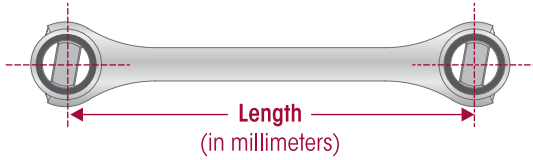

In five (5) millimeter increments between 360 mm and 790 mm

5x

PERFORMANCE LIFE





■ **One-piece Torque Rods**

Smart Numbering System | ULTRA ROD

Most Hendrickson one-piece torque rods follow the **Smart Numbering System**, those are the ones that contain two-number prefix **62XXX**, see illustration below. One-piece torque rods may have the same length and bushing configuration, but the torsional bushing position will differ creating a different part number. All other one-piece torque rods that are not part of the Smart Numbering System on the following pages are shown by their five digit prefix number with the configurations cross-referenced in their respective table.

ULTRA ROD SMART NUMBERING SYSTEM

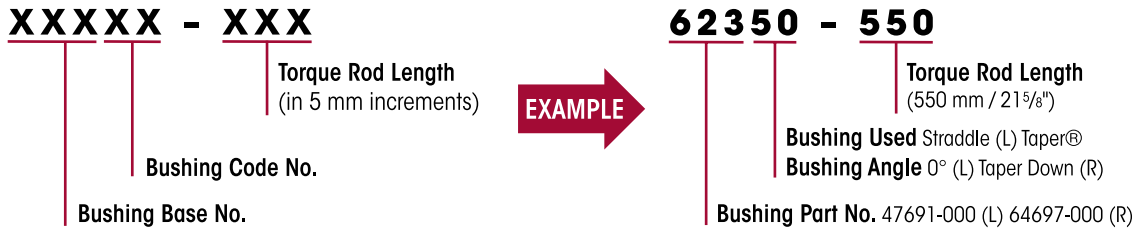

- The first three (3) digits of the part number provide the bushing **base number** to identify the corresponding bushing part numbers. The fourth and fifth digits provide the bushing **code number** to identify the corresponding bushing type and angle and the last three (3) digits after the dash indicate **torque rod length**, (center to center in millimeters).

XXXXX - XXX

BUSHING BASE NUMBER (First 3 digits of the Part No.)

ONE-PIECE TORQUE RODS

BASE NUMBER	BUSHING PART NO.	
	Left	Right
ULTRA ROD		
620	47691-000L	47691-000L
621	68304-000L	68304-000L
622	47691-000L	64809-000L
623	47691-000L	64697-000L
624	64809-000L	64809-000L
625	64697-000L	64697-000L
626	69210-000L	64697-000L
627	69210-000L	69210-000L
628	47691-000L	66735-000L
629	67746-000L	66735-000L





X X X **X X** - X X X

BUSHING CODE NUMBER (4th and 5th digits of the Part No.)

BUSHING TYPE - STRADDLE • STRADDLE

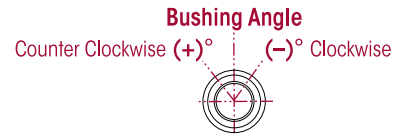
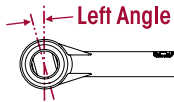

Bushing Code	Bushing Angle		Bushing Code	Bushing Angle		Bushing Code	Bushing Angle		Bushing Code	Bushing Angle	
	Left	Right		Left	Right		Left	Right		Left	Right
00	0°	0°	12	9°	9°	24	0°	5°	36	8°	4°
01	0°	10°	13	20°	10°	25	4°	10°	37	6.5°	6°
02	10°	0°	14	7°	7°	26	0°	35°	38	4°	7°
03	0°	15°	15	4°	8°	27	8°	5°	39	-4°	-8°
04	0°	30°	16	9°	13°	28	-5°	5°	40	-4°	-14°
05	20°	20°	17	3°	0°	29	20°	-10°	41	2°	-11°
06	10°	15°	18	4°	0°	30	2°	13°	42	8°	8°
07	10°	10°	19	5°	0°	31	7°	2.5°	43	2°	5°
08	7.5°	90°	20	7°	0°	32	2°	2.5°	44	15°	15°
09	15°	10°	21	10°	5°	33	11°	6°	45	0°	37°
10	1°	1°	22	0°	50°	34	2.5°	7°	46	-10°	10°
11	5°	5°	23	0°	4°	35	15°	8°	47	-3°	-3°

BUSHING TYPE - STRADDLE • TAPER



Bushing Code	Bushing Angle		Bushing Code	Bushing Angle		Bushing Code	Bushing Angle	
	Left	Right		Left	Right		Left	Right
50	0°	Taper Down	53	16°	Taper Down	56	10°	Taper Down
51	2°		54	11°		57	20°	
52	5°		55	-4°		58	13°	

BUSHING TYPE - TAPER • TAPER

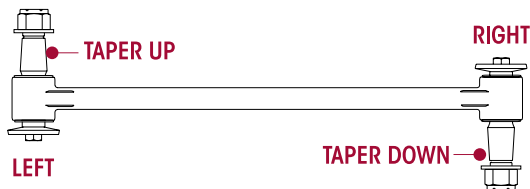

Bushing Code	Bushing Angle		Bushing Code	Bushing Angle	
	Left	Right		Left	Right
98	Taper Up	Taper Down	99	Taper Down	Taper Down



One-piece Torque Rods | ULTRA ROD

* Prefix 48411-

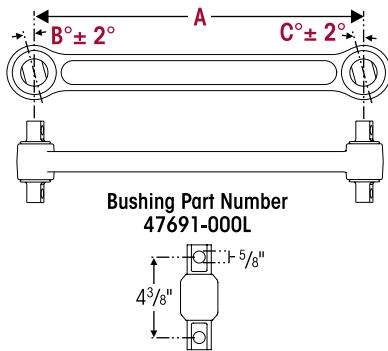

PART NO.	A		B°	C°	PART NO.	A		B°	C°
	mm	inch				mm	inch		
48411-013	366	14 ⁷ / ₁₆	0°	0°	48411-004	402	15 ¹ / ₁₆	0°	-5°
48411-016			4°	4°	48411-015			5°	6°
48411-006			10°	10°	48411-005			10°	10°
48411-010	375	14 ³ / ₄	0°	0°	48411-001			15°	10°
48411-014			10°	10°	48411-011			25°	-5°
48411-009	402	15 ¹ / ₁₆	0°	0°					

* Prefix 57950- • 58519-

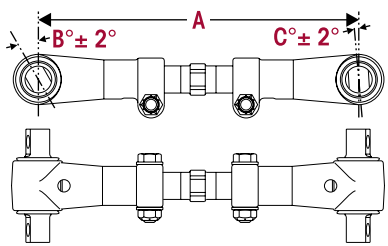

PART NO.	A		B°	C°	D Bolt Size
	mm	inch			
57950-007	366	14 ⁷ / ₁₆	10°	10°	1/2" x 3" Length
58519-007					M12 x 80 mm

* Prefix 58745-

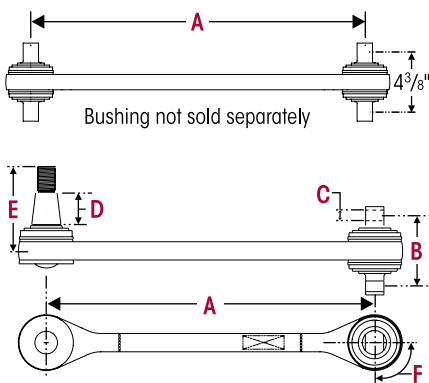

PART NO.	A		PART NO.	A		PART NO.	A	
	mm	inch		mm	inch		mm	inch
58745-002	584.4	23	58745-011	626	24 ⁵ / ₈	58745-006	649.2	25 ¹ / ₁₆
58745-010	616	24 ¹ / ₄						

PART NO.	A		B	C	D	E	F
	mm	inch					
58745-009	514.4	20 ¹ / ₄	4 ³ / ₈ "	5 ⁵ / ₈ "	1 ¹ / ₂ "	5 ³ / ₁₆ "	90°

* Prefix 58757-

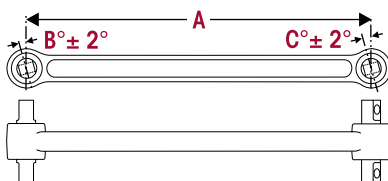

PART NO.	A		B°	C°
	mm	inch		
58757-005	546.1	21 ¹ / ₂	0°	0°
58757-660	660	26		10°

* Prefix 60641-

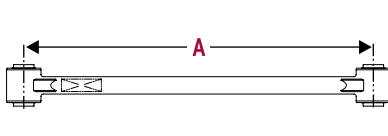

PART NO.	A		PART NO.	A	
	mm	inch		mm	inch
60641-620	620	24 ⁷ / ₁₆	60641-660	660	26
60641-640	640	25 ³ / ₁₆	60641-775	775	30 ¹ / ₂

* These torque rods are not part of Hendrickson Smart Numbering System.

ONE-PIECE TORQUE RODS



One and Two-piece Torque Rods and Replacement Bushings

* Prefix 60827-

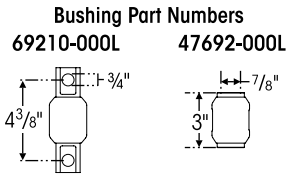
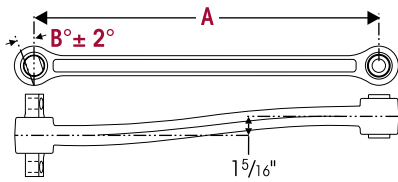

PART NO.	A		B°
	mm	inch	
60827-605A	605	23 ^{13/16}	18.3°
60827-605B			-18.3°
60827-645A	645	25 ^{3/8}	17.3°
60827-645B			-17.3°

** Prefix 620XX-

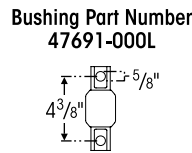
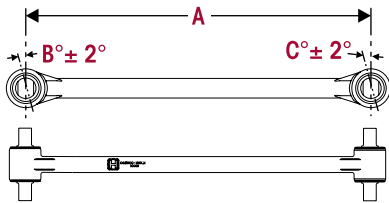

PART NO.	A		B°	C°	PART NO.	A		B°	C°	PART NO.	A		B°	C°					
	mm	inch				mm	inch				mm	inch							
62000-420	420	16 ^{9/16}	0	0	62000-615	615	24 ^{3/16}	0	0	62001-495	495	19 ^{1/2}	0	10					
62000-430	430	16 ^{15/16}			62000-620	620	24 ^{7/16}			62001-515	515	20 ^{1/4}			62001-665	665	26 ^{3/16}		
62000-525	525	20 ^{11/16}			62000-620N	620	24 ^{7/16}			62001-520	520	20 ^{1/2}			62001-670	670	26 ^{3/8}		
62000-545	545	21 ^{7/16}			62000-630	630	24 ^{13/16}			62001-535	535	21 ^{1/16}			62001-675	675	26 ^{9/16}		
62000-560	560	22 ^{1/16}			62000-635	635	25			62001-540	540	21 ^{1/4}			62001-680	680	26 ^{3/4}		
62000-560N	560	22 ^{1/16}			62000-640	640	25 ^{3/16}			62001-545	545	21 ^{7/16}			62001-685	685	27		
62000-565	565	22 ^{1/4}			62000-645	645	25 ^{3/8}			62001-560	560	22 ^{1/16}			62001-690	690	27 ^{3/16}		
62000-565N	565	22 ^{1/4}			62000-645N	645	25 ^{3/8}			62001-565	565	22 ^{1/4}			62001-735	735	28 ^{15/16}		
62000-570	570	22 ^{7/16}			62000-650	650	25 ^{5/16}			62001-570	570	22 ^{7/16}			62001-740	740	29 ^{1/8}		
62000-575	575	22 ^{5/8}			62000-660	660	26			62001-580	580	22 ^{3/16}			62005-420	420	16 ^{9/16}	20	20
62000-580	585	22 ^{3/16}			62000-660N	660	26			62001-585	585	23			62007-365	365	14 ^{3/8}	10	10
62000-590	590	23 ^{1/4}			62000-670	670	26 ^{3/8}			62001-605	605	23 ^{3/16}			62008-620	620	24 ^{7/16}	7.5	9
62000-595	595	23 ^{7/16}			62000-675	675	26 ^{9/16}			62001-610	610	24			62009-400	400	15 ^{3/4}	15	10
62000-595N	595	23 ^{7/16}			62000-700	700	27 ^{9/16}			62001-615	615	24 ^{3/16}			62011-415N	415	16 ^{5/16}	5	5
62000-600	600	23 ^{5/8}			62000-710	710	27 ^{15/16}			62001-615	615	24 ^{3/16}			62011-620	620	24 ^{7/16}		
62000-605	605	23 ^{3/16}			62000-720	720	28 ^{3/8}			62001-620	620	24 ^{7/16}			62011-720	720	28 ^{3/8}	4	8
62000-610	610	24			62000-750	750	29 ^{1/2}			62001-620	620	24 ^{7/16}			62012-465	465	18 ^{5/16}		
										62001-630	630	24 ^{13/16}			62015-735	735	28 ^{15/16}	4	14
										62001-635	635	25			62039-440N	440	17 ^{9/16}		
										62001-640	640	25 ^{3/16}			62040-475N	475	17 ^{11/16}	4	14
						62001-645	645	25 ^{3/8}	62045-615N	615	24 ^{3/16}	0	37						
						62001-650	650	25 ^{5/16}											
						62001-655	655	25 ^{13/16}											
						62001-660	660	26											

ONE-PIECE TORQUE RODS

- * These torque rods are not part of Hendrickson Smart Numbering System.
- ** These popular one-piece torque rods follow the Smart Numbering System and are available from 365 mm to 895 mm in increments of 5 mm. Contact Hendrickson for lengths not shown. These ULTRA ROD assemblies are also available with non-rebushable bushings and can be identified by the Suffix N after any part number.
- ◆ Torque rod bushings are non-serviceable, replace the complete torque rod assembly that includes bushings.



** Prefix 62350-

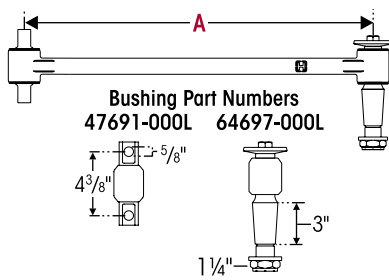

PART NO.	A		PART NO.	A		PART NO.	A	
	mm	inch		mm	inch		mm	inch
62350-450	450	17 ¹ / ₁₆	62350-605	605	23 ³ / ₁₆	62350-645	645	25 ³ / ₈
62350-470	470	18 ¹ / ₂	62350-610	610	24	62350-655	655	25 ¹ / ₁₆
62350-535	535	21 ¹ / ₁₆	62350-615	615	24 ³ / ₁₆	62350-760	760	29 ¹ / ₁₆
62350-550	550	21 ⁵ / ₈	62350-620	620	24 ⁷ / ₁₆	62350-800	800	31 ¹ / ₂
62350-560	560	22 ¹ / ₁₆	62350-630	630	24 ¹ / ₁₆	62350-880	880	34 ⁵ / ₈
62350-570	570	22 ⁷ / ₁₆	62350-635	635	25	62350-910	910	35 ¹ / ₁₆
62350-590	590	23 ¹ / ₄						

** Prefix 62650-

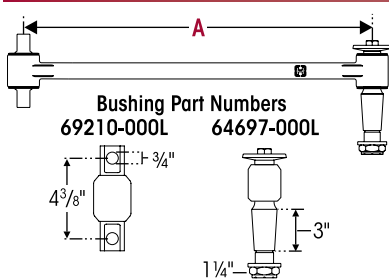

PART NO.	A		PART NO.	A		PART NO.	A	
	mm	inch		mm	inch		mm	inch
62650-500	500	19 ¹ / ₁₆	62650-535	535	21 ¹ / ₁₆	62650-630	630	24 ¹ / ₁₆
62650-505	505	19 ⁷ / ₈	62650-610	610	24	62650-645	645	25 ³ / ₈
62650-525	525	20 ¹ / ₁₆						

** Prefix 62700-

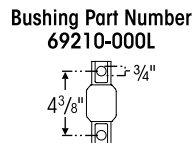
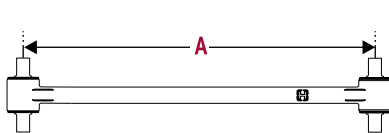

PART NO.	A	
	mm	inch
62700-570	570	22 ⁷ / ₁₆

* Prefix 64717-

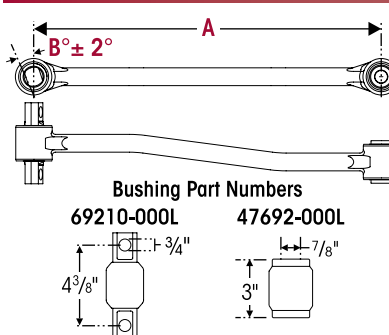

PART NO.	A		B°	PART NO.	A		B°
	mm	inch			mm	inch	
64717-590A	590	23 ¹ / ₄	+17.8°	64717-620A	620	24 ⁷ / ₁₆	+17.8°
64717-590B			-17.8°	64717-620B			-17.8°
64717-605A	605	23 ³ / ₁₆	+17.8°	64717-645A	645	25 ³ / ₈	+17.8°
64717-605B			-17.8°	64717-645B			-17.8°

* These torque rods are not part of Hendrickson Smart Numbering System.

** These popular one-piece torque rods follow the Smart Numbering System and are available from 365 mm to 895 mm in increments of 5 mm. Contact Hendrickson for lengths not shown. These ULTRA ROD assemblies are also available with non-rebushable bushings and can be identified by the Suffix N after any part number.

◆ Torque rod bushings are non-serviceable, replace the complete torque rod assembly that includes bushings.



One and Two-piece Torque Rods and Replacement Bushings

* Prefix 65285-

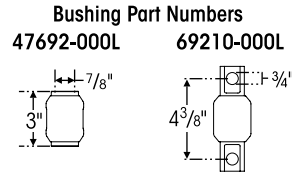
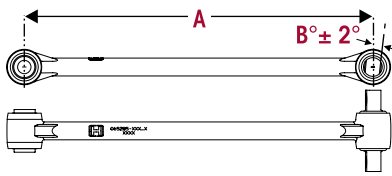

PART NO.	A		B°
	mm	inch	
65285-620	620	24 7/16	6°
65285-685	685	27	0°

* ♦ Prefix 65302-

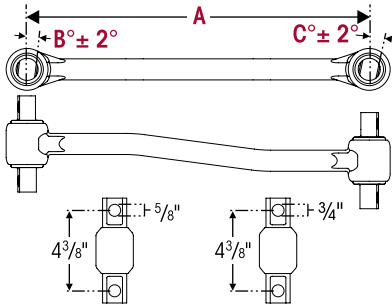

PART NO.	A		B°	C°	PART NO.	A		B°	C°
	mm	inch				mm	inch		
65302-365A/B	365	14 3/8	5°	6°	65302-510A/B	510	20 1/16	7°	16°
65302-455A/B	455	17 5/16	5°	6°	65302-510C/D	510	20 1/16	13.5°	17.2°
65302-460A/B	460	18 1/8	7°	8°	65302-515A/B	515	20 1/4	7°	17°
65302-470A/B	470	18 1/2	7°	9.5°	65302-520A/B	520	20 1/2	7°	17.5°
65302-475A/B	475	18 11/16	7°	11.5°	65302-525A/B	525	20 11/16	7°	18°
65302-480A/B	480	18 7/8	5.4°	8.3°	65302-530A/B	530	20 7/8	7°	19°
65302-485A/B	485	19 1/8	5.4°	9.2°	65302-535A/B	535	21 1/16	9°	5°
65302-490A/B	490	19 5/16	5.4°	9.9°	65302-550A/B	550	21 3/8	13°	22°
65302-495A/B	495	19 1/2	5°	13°					

* Prefix 66359-

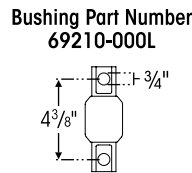
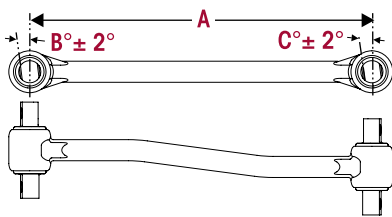

PART NO.	A		B°	C°
	mm	inch		
66359-585A/B	585	23	13°	2°
66359-590A/B	590	23 1/4	13°	2°
66359-595A/B	595	23 7/16	12°	2°
66359-600A/B	600	23 3/8	13°	2°
66359-650A/B	650	25 5/16	12°	10°
66359-660A/B	660	26	13°	9°
66359-670A/B	670	26 3/8	12°	8°

* ♦ Prefix 67274-

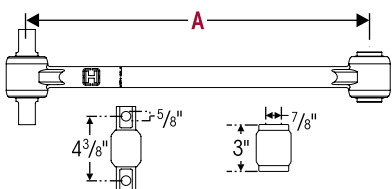

PART NO.	A		PART NO.	A		PART NO.	A	
	mm	inch		mm	inch		mm	inch
67274-470	470	18 1/2	67274-530	530	20 7/8	67274-560	560	22 1/16
67274-510	510	20 1/16	67274-540	540	21 1/4	67274-565	565	22 1/4
67274-515	515	20 1/4	67274-545	545	21 7/16	67274-570	570	22 7/16
67274-520	520	20 1/2	67274-550	550	21 5/8	67274-575	575	22 5/8
67274-525	525	20 11/16	67274-555	555	21 7/8			

* These torque rods are not part of Hendrickson Smart Numbering System.

♦ Torque rod bushings are non-serviceable, replace the complete torque rod assembly that includes bushings.



* ♦ Prefix 67428-

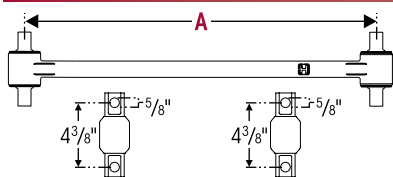

PART NO.	A		PART NO.	A		PART NO.	A	
	mm	inch		mm	inch		mm	inch
67428-365	365	14 ³ / ₈	67428-440	440	17 ⁵ / ₁₆	67428-480	480	18 ⁷ / ₈
67428-375	375	14 ³ / ₄	67428-445	445	17 ¹ / ₂	67428-485	485	19 ¹ / ₈
67428-420	420	16 ⁷ / ₁₆	67428-450	450	17 ¹ / ₁₆	67428-490	490	19 ⁵ / ₁₆
67428-425	425	16 ³ / ₄	67428-460	460	18 ¹ / ₈	67428-495	495	19 ¹ / ₂
67428-430	430	16 ¹⁵ / ₁₆	67428-465	465	18 ⁵ / ₁₆	67428-500	500	19 ¹ / ₁₆
67428-435	435	17 ¹ / ₈	67428-470	470	18 ¹ / ₂	67428-505	505	19 ⁷ / ₈
			67428-475	475	18 ¹ / ₁₆			

* Prefix 79320-

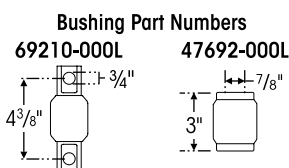
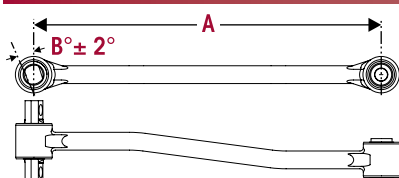

PART NO.	A		B°
	mm	inch	
79320-630	630	24 ¹³ / ₁₆	0°

* Prefix 80918-

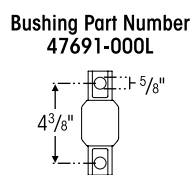
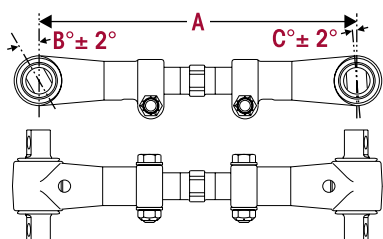

PART NO.	A		B°	C°	D Bolt Size
	mm	inch			
80918-001	660	14 ⁷ / ₁₆	11°	3°	1/2" x 3" Length
80918-002			-5°		

* These torque rods are not part of Hendrickson Smart Numbering System.

♦ Torque rod bushings are non-serviceable, replace the complete torque rod assembly that includes bushings.



One-piece Torque Rods | SPECIALTY

* ♦ PRIMAAX EX • FIREMAAX EX

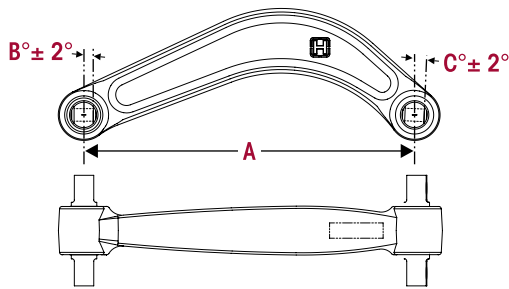

Shown 68801-435

PART NO.	A		B°	C°
	mm	inch		
67219-435	435	17 ¹ / ₈	0°	2.5°
67219-475	475	18 ¹ / ₁₆	0°	11°
68801-435	435	17 ¹ / ₈	0°	2.5°
68801-475	475	18 ¹ / ₁₆	0°	11°
77128-435	435	17 ¹ / ₈	0°	6°

* HTB LT • HTB 210

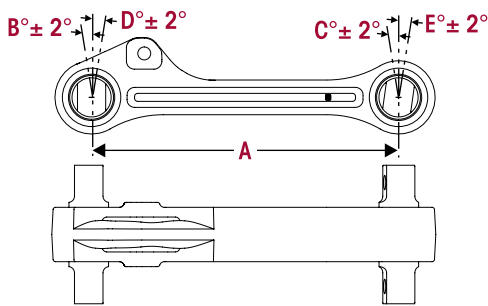

PART NO.	A		B°	C°	D°	E°
	mm	inch				
♦77906-398	398	15 ¹ / ₁₆	0°	8°	-	-
78562-001			4°	0°	-	-
78562-002			-	-	2°	6°
78562-003			13°	0°	-	-

* Prefix 13422-

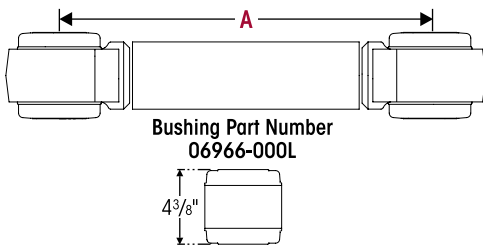

PART NO.	A		PART NO.	A		PART NO.	A	
	mm	inch		mm	inch		mm	inch
13422-039	546.1	21 ¹ / ₂	13422-075	655	25 ³ / ₁₆	13422-009	762	30
13422-068	552.5	21 ³ / ₄	13422-005	660.4	26	13422-018	781.1	30 ³ / ₄
13422-029	558.8	22	13422-002	673.1	26 ¹ / ₂	13422-025	787.4	31
13422-026	571.5	22 ¹ / ₂	13422-010	679.5	26 ³ / ₄	13422-020	806.5	31 ³ / ₄
13422-069	577.9	22 ³ / ₄	13422-033	685.8	27	13422-012	812.8	32
13422-063	584.2	23	13422-011	692.2	27 ¹ / ₄	13422-004	825.5	32 ¹ / ₂
13422-044	596.9	23 ¹ / ₂	13422-040	698.5	27 ¹ / ₂	13422-003	838.2	33
13422-019	412.8	16 ¹ / ₄	13422-014	603.3	23 ³ / ₄	13422-045	704.9	27 ³ / ₄
13422-060	476.3	18 ³ / ₄	13422-027	609.6	24	13422-070	711.2	28
13422-036	495.3	19 ¹ / ₂	13422-022	536.6	21 ¹ / ₈	13422-072	713	28 ¹ / ₁₆
13422-013	508	20	13422-064	539.8	21 ¹ / ₄	13422-072	713	28 ¹ / ₁₆
13422-013	508	20	13422-053	541.3	21 ⁵ / ₁₆	13422-024	723.9	28 ¹ / ₂
13422-067	520.7	20 ¹ / ₂	13422-074	542	21 ⁵ / ₁₆	13422-046	743	29 ¹ / ₄
			13422-023	647.7	25 ¹ / ₂	13422-071	749.3	29 ¹ / ₂

* These torque rods are not part of Hendrickson Smart Numbering System.
 ♦ Torque rod bushings are non-serviceable, replace the complete torque rod assembly with bushings.



■ Torque Rod Bushings

Bushings | XTRB, Bonded and Conventional

Whether the application is a lighter duty on-highway truck or a severe vocational application, Hendrickson offers the right bushings for the job.

**XTRB™
BUSHINGS**

XTRB™



XTRB Bushings used for severe duty applications, are a combination of chemical bonding and a mechanical design with a hardened steel bar pin, steel casing, and bonded rubber.

**BONDED
BUSHINGS**

BONDED



Bonded Bushings work great in a vocational environment and are easy to install with the funnel tool.

**CONVENTIONAL
BUSHINGS**

CONVENTIONAL



Conventional Bushings press-in easily and provide the durability needed for medium applications.

Bushing Funnel Tool | ULTRA ROD • ULTRA ROD PLUS



Re-bushing a torque rod with a bonded bushing is easier with the use of a funnel tool. Contact your authorized Hendrickson distributor to order the Funnel Tool.



ULTRA ROD Bushings
Use Tool Part No. **66086-001L**



ULTRA ROD PLUS Bushings
Use Tool Part No. **66086-000L**

SPECIAL OFFER

Kit No. **34013-113** includes **EIGHT ULTRA ROD PLUS Bushings**
Bushing Part No. **64400-002L** and **ONE Funnel Tool** Part No. **66086-000L**

TORQUE ROD BUSHINGS



One and Two-piece Torque Rods and Replacement Bushings



Straddle

Shown 66649-002L



Offset Straddle

Shown 47699-001L

XTRB BUSHINGS

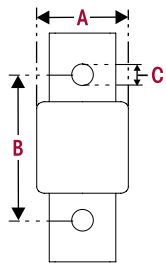

PART NO.	INCHES		
	A	B	C
66649-002L	2 ³ / ₄	4 ³ / ₈	5 ⁵ / ₈
66649-003L	2 ³ / ₄	5 ¹ / ₄	1 ⁵ / ₁₆
66649-005L	2 ³ / ₄	4 ³ / ₈	1 ³ / ₁₆

BONDED BUSHINGS

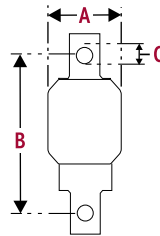

PART NO.	INCHES		
	A	B	C
66734-000L	2	5 ¹ / ₁₆	3 ³ / ₄

BONDED BUSHINGS

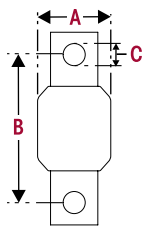

PART NO.	INCHES		
	A	B	C
47691-000L	2	4 ³ / ₈	5 ⁵ / ₈
69210-000L	2	4 ³ / ₈	3 ³ / ₄
67746-000L	2	4 ³ / ₈	7 ⁷ / ₈

CONVENTIONAL BUSHINGS

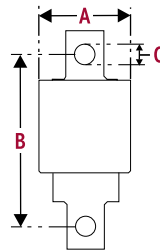

PART NO.	INCHES		
	A	B	C
46734-000L*	2 ³ / ₄	5 ¹ / ₁₆	3 ³ / ₄
47699-001L	3	5 ¹ / ₁₆	3 ³ / ₄

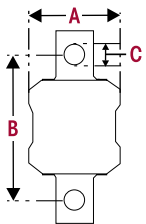

PART NO.	INCHES		
	A	B	C
64400-003L	3 ¹ / ₄	5 ¹ / ₄	7 ⁷ / ₈
64400-005L*	3 ¹ / ₄	4 ³ / ₈	3 ³ / ₄

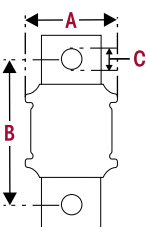

PART NO.	INCHES		
	A	B	C
64400-002L*	3 ¹ / ₄	4 ³ / ₈	5 ⁵ / ₈
64400-009L*	3 ¹ / ₄	5 ¹ / ₁₆	3 ³ / ₄

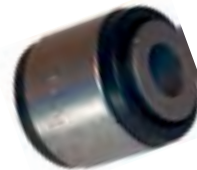

Thru Hole

Shown 45477-000L

CONVENTIONAL BUSHINGS

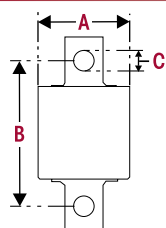

PART NO.	INCHES		
	A	B	C
44694-000L	2 ¹ / ₁₆	4 ³ / ₈	5 ⁵ / ₈
44695-000L*	2 ³ / ₄	4 ³ / ₈	5 ⁵ / ₈
48304-000L	3 ¹ / ₂	5 ¹ / ₄	7 ⁷ / ₈
49210-000L*	2 ³ / ₄	4 ³ / ₈	3 ³ / ₄
57256-000L	2 ⁷ / ₁₆	4 ³ / ₈	5 ⁵ / ₈

BONDED BUSHINGS

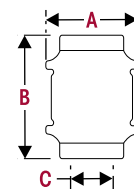

PART NO.	INCHES		
	A	B	C
64400-010	3 ¹ / ₄	3 ³ / ₄	1 ¹ / ₈

CONVENTIONAL BUSHINGS

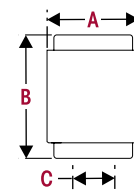

PART NO.	INCHES		
	A	B	C
24504-000L	2 ⁷ / ₈	3 ³ / ₄	1 ¹ / ₈
45477-000L	3	3 ³ / ₄	1 ¹ / ₈
46736-000L*	2 ³ / ₄	3 ³ / ₄	1 ¹ / ₈
47692-000L	2	3	1 ⁵ / ₁₆
65477-000L	2	3 ³ / ₄	1 ¹ / ₈

* Part numbers in gray denotes interchangeable conventional and bonded bushings.



Taper Bushings

Shown 66649-004L

XTRB BUSHINGS

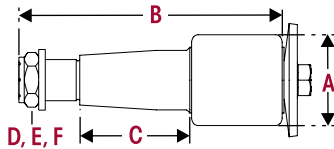

PART NO.	INCHES			FASTENER		
	A	B	C	THREAD D	LOCKNUT E	WASHER F
66649-004L	2¾	8	3	1¼"	29749-000	30574-000

BONDED BUSHINGS

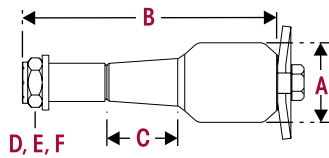

PART NO.	INCHES			FASTENER		
	A	B	C	THREAD D	LOCKNUT E	WASHER F
64697-000L	2	8	3	1¼"	29749-000	30574-000
64809-000L	2	6⅝	2	1⅛"	29896-000	-
66735-000L	2	7	1⅞	1¼"	29749-000	30574-000

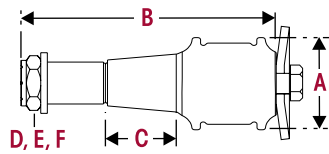

64400-004L*	3¼	8	3	1¼"	29749-000	30574-000
64400-006L	3¼	8¾	2½	1¾"	30603-000	-
64400-007L*	3¼	7	1¾	1¼"	29749-000	30574-000
64400-008L*	3¼	6⅝	1⅞	1⅛"	29896-000	-

CONVENTIONAL BUSHINGS

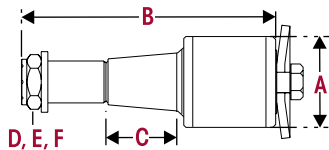

PART NO.	INCHES			FASTENER		
	A	B	C	THREAD D	LOCKNUT E	WASHER F
44697-000L*	2¾	8	3	1¼"	29749-000	30574-000
46735-000L*	2¾	7	1⅞	1¼"	29749-000	30574-000
46737-000L*	2¾	6⅝	1⅞	1⅛"	29896-000	-

TORQUE ROD BUSHINGS



Torque Rod Brackets

TORQUE ROD STRADDLE MOUNT FRAME BRACKETS

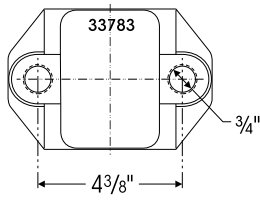

PART NO.	DESCRIPTION
33783-000	Straddle Mount, 3/4" Bolt Mounting (Heavy Duty)

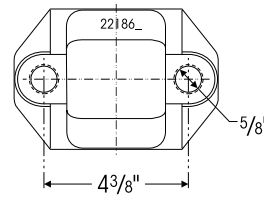

PART NO.	DESCRIPTION
22186-000	Straddle Mount, 5/8" Bolt Mounting

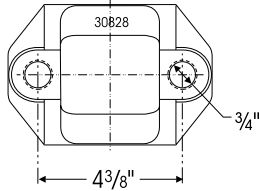

PART NO.	DESCRIPTION
30828-000	Straddle Mount, 3/4" Bolt Mounting

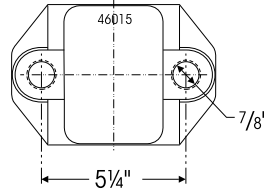

PART NO.	DESCRIPTION
46015-000	Straddle Mount, 7/8" Bolt Mounting (Heavy Duty)

TRANSVERSE TORQUE ROD AXLE BRACKETS

Hendrickson does not set the guidelines with regard to transverse torque rod axle bracket heights or footprints, due to the many variations of axle combinations, frame widths, and suspension ride heights. Refer to the vehicle manufacturer for component specifications.

Hendrickson supplies transverse torque rod axle brackets (that are not specific to any vehicle or application) as shown below.

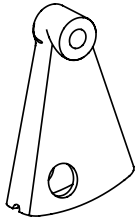

Axle Bracket Part Number	Axle Model Number		* It may be necessary to cross-reference the provided axle model number to the current vehicle manufacturer's model number.
48042-000	*Dana (Eaton)	Eaton D460	
		Eaton D480	
46868-000	*Meritor (Rockwell)	Rockwell SL100	
		Rockwell SQ100	
		Rockwell SQHP	

Actual product performance may vary depending upon vehicle configuration, operation, service and other factors.
All applications must comply with applicable Hendrickson specifications and must be approved by the respective vehicle manufacturer with the vehicle in its original, as-built configuration.
Contact Hendrickson for additional details regarding specifications, applications, capacities, and operation, service and maintenance instructions.

Call Hendrickson at 1.866.755.5968 (toll-free) or 1.630.910.2800 for additional information.



www.hendrickson-intl.com

TRUCK COMMERCIAL VEHICLE SYSTEMS

800 South Frontage Road
Woodridge, IL 60517-4904 USA
1.866.755.5968 (Toll-free U.S. and Canada)
1.630.910.2800 (Outside U.S. and Canada)
Fax 1.630.910.2899

45745-148 Rev G 01-25

© 2004 – 2025 Hendrickson USA, L.L.C. All Rights Reserved. All trademarks shown are owned by Hendrickson USA, L.L.C., or one of the affiliates, in one or more countries.

Information contained in this literature was accurate at the time of publication. Product changes may have been made after the copyright date that are not reflected.

Printed in United States of America