

H PARTS LIST

Truck Suspension Past Generation Products

LIT NO: SP-179

DATE: March 2021

REVISION: G

CONTENTS

DESCRIPTION	PAGE
AL405™ • MaxAir	2
AR™ 34K • 38K	4
E4™ 34K • 38K	6
E4 36K • 40K	8
HA™ 36K • 40K • 46K	10
HFS™ 36K • 40KLH • 40K	14
HN® 40K • 46K	16
HN/HNT™ 40K • 46K	18
SR™ 34K • 38K	20
V4™ 34K • 38K	21
Special Tools	22

SOLUTIONS AT WORK — Since 1913, Hendrickson's only business has been to serve the needs of the commercial vehicle industry. Today, Hendrickson is a major supplier to every North American heavy-duty truck and trailer OEM, as well as many manufacturers around the world.

Our goal continues to be providing the most technologically advanced and differentiated products available. We will continue to support past generation products to the best of our ability, although some components may no longer be available. We encourage you to contact our Tech Services staff for questions or to upgrade your suspension.



Parts Identification
truckparts@hendrickson-intl.com



Additional Hendrickson
Product Information
www.hendrickson-intl.com

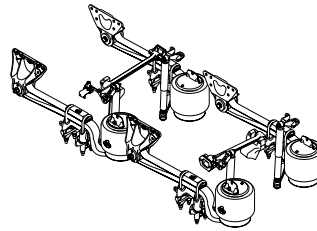

AL405 • MaxAir

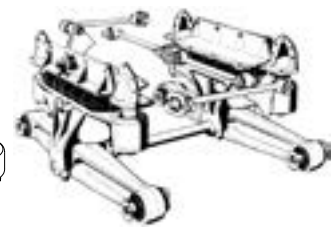

AR 34K • 38K



E4 34K • 38K



E4 36K • 40K



HA 36K • 40K • 46K

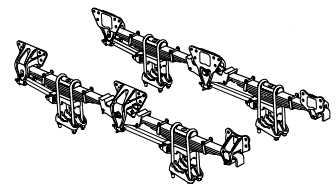

HFS 36K • 40KLH • 40K

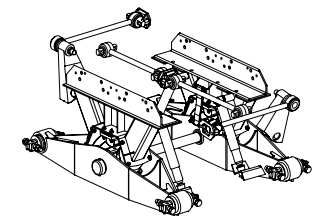

HN 40K • 46K

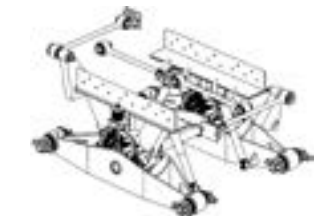

HN/HNT 40K • 46K

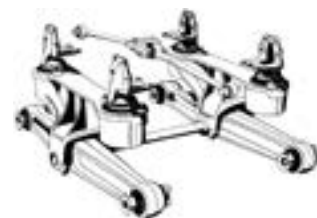

SR 34K • 38K

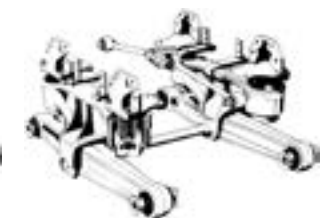

V4 34K • 38K



■ Obsolete January 2004

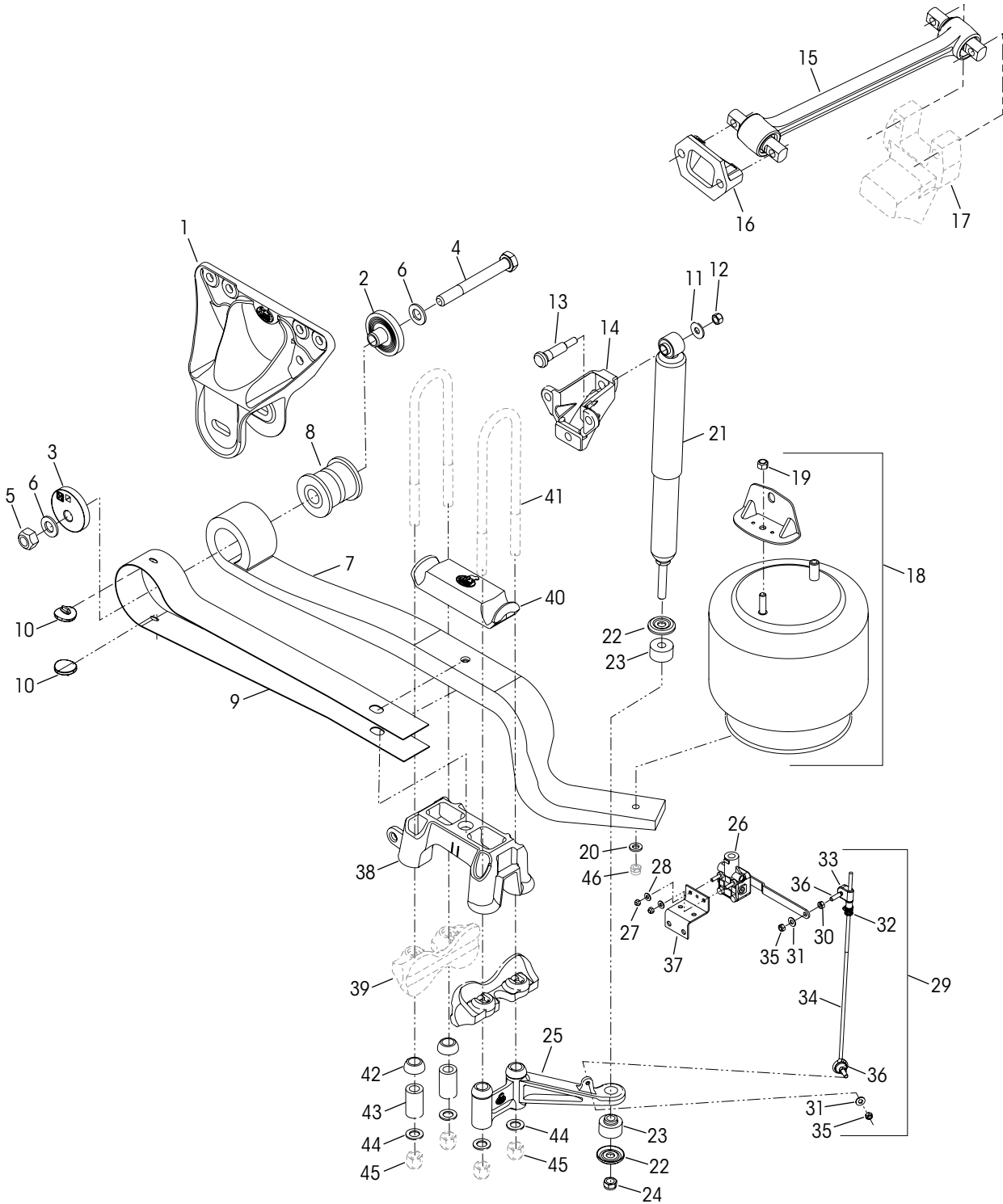



KEY NO.	PART NO.	DESCRIPTION	VEHICLE *QTY.	KEY NO.	PART NO.	DESCRIPTION	VEHICLE *QTY.
1	58772-000	Frame Hanger Ductile Iron, Standard, <i>Replaces 58694-001 and 58772-001</i>	4	22		****Retaining Washers	
2	60497-000	**QUIK-ALIGN® Concentric Base	6	23		****Rubber Bushings	
	60661-000L	***QUIK-ALIGN Concentric Base Aluminum option	6	24		****5/8" UNC Locknut	
3	60496-000	**QUIK-ALIGN Eccentric Base	2	25		Lower Shock Bracket	
	60662-000L	***QUIK-ALIGN Eccentric Base Aluminum Option	2		58701-001	Left Hand	2
4	58705-003	7/8"-9 UNC-2A x 7 1/2" Bolt	4		58702-001	Right Hand	2
	58705-005	***7/8"-9 UNC-2A x 8" Bolt Aluminum Option	4	26	59899-000L	Height Control Valve, Includes Key Nos. 27-28	1
5	60266-000	7/8"-9 UNC-2B Locknut	4	27		****1/4"-20 UNC Locknut	
6	22962-034	Hardened Flat Washer	8	28		****1/4" Hardened Washer	
7		Main Support Member, Includes Key Nos. 8-10		29	58994-014	Height Control Valve Linkage Assembly Includes Key Nos. 30-36	1
	58691-000	Left Hand	2	30		****5/16"-18 UNC Nut	
	58768-000	Right Hand	2	31		****9/16" Hardened Washer	
8		****QUIK-ALIGN Pivot Bushing		32		****Valve Arm Clamp	
9		****Flexi-Wrap Strip		33		****Valve Arm Joint	
10		****Rubber Isolator Pad		34		****Extension Rod	
	58692-000	Shock Frame Hanger Assembly Includes Key Nos. 11-14	4	35		****5/16"-18 UNC Locknut	
11	22962-031	1/2" Hardened Washer	4	36		****9/16"-18 UNC Stud	
12	49846-000	1/2"-13 UNC Locknut	4	37	57975-000	Height Control Valve Bracket	1
13	50368-000	1/2"-13 UNC 3.72" Bolt	4	38		Spring Seat	4
14		****Shock Bracket Cast			59580-006	Front - 4 1/2°	
15	62000-560	Transverse Rod Assembly, <i>Replaces 58757-006</i>	2		64237-003	Rear - 7 1/2°	
16	22186-000	Transverse Rod Frame Bracket	2		59582-005	Rear - 12°	
17		****Transverse Rod Axle Bracket	2		59582-008	Rear - 13 1/2°	
18	58786-002	Air Spring Assembly, Includes Key No. 19	4	39		****Welded Axle Bracket	8
19		****Air Spring Locknut		40	58775-002	Top Pad	4
20	22962-014	Air Spring Flat Washer	4	41		****3/4" U-bolt	8
21	57241-006L	Shock Absorber, Includes Key Nos. 22-24	4	42	49947-000	Spherical Washer	8
				43	58776-000	U-bolt Spacer Tube	8
				44	22962-001	3/4" Flat Washer	16
				45		****3/4" Locknut	16
				46		****Air Spring Locknut	4

NOTES: * Quantities specified are shown for tandem suspension.

** No longer available. Contact Hendrickson to upgrade to a conversion.

*** When using the aluminum option, it is mandatory to use the aluminum bolt Part No. 58705-005.

**** Item included in kit/assembly only, part not sold separately.

***** Not supplied by Hendrickson, used for reference only. Hendrickson is not responsible for components supplied by the vehicle manufacturer. For assistance with maintenance and rebuild instructions on these components see vehicle manufacturer.

Hendrickson Lit. No. 45745-164 – MaxAir Ride Height Gauge for vehicles built after March 19, 2001 can be obtained online at www.hendrickson-intl.com/Litform

■ Obsolete January 1989

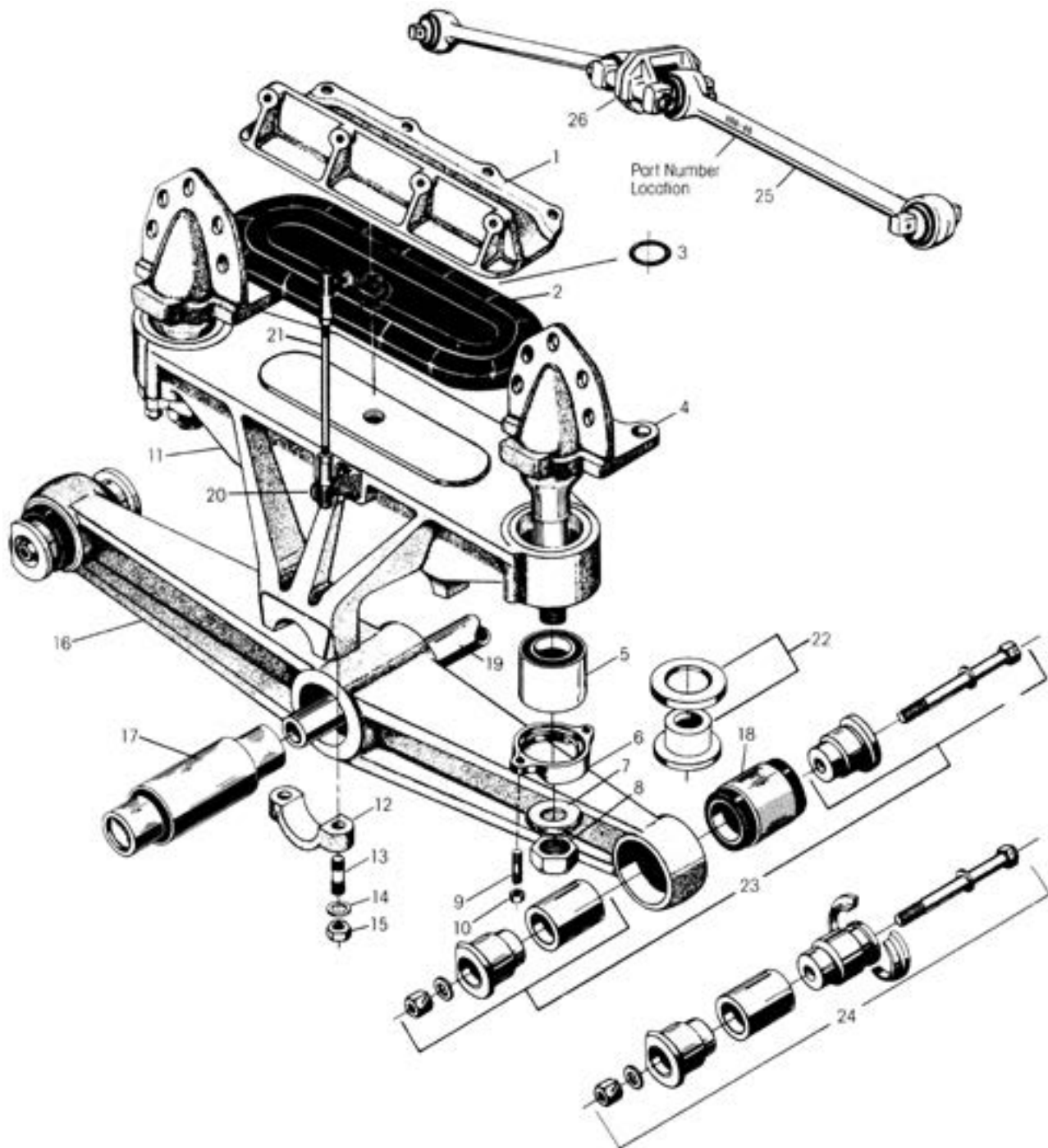



KEY NO.	PART NO.	DESCRIPTION	VEHICLE QTY.	KEY NO.	PART NO.	DESCRIPTION	VEHICLE QTY.
1	10327-001	*Air Spring Frame Hanger	2	18		End Bushing	4
2	13233-001	*Air Spring	2	a	06969-000L	34K - 5¼" Length	
3	35475-000	*O-Ring – Air Spring Orifice	2	b	45900-000L	34K • 38K - 5¾" Length	
4	14059-023	*Frame Hanger, Includes Key Nos. 7-8	4	19		Cross Tube - 447/8" Length	1
5	19279-000L	Vertical Bushing	4		44642-008L	34K	
6	05917-000	Cap	4		44643-009L	38K	
7	08536-000	1½" Concave Washer	4	20	22202-000	*Linkage Rod Bracket	2
8	25151-000	1½"-12 UNF Locknut	4	21	22110-002	*Linkage Rod	2
9	19111-001	5/8"-18 UNF Stud	8	22	31005-002	Optional Rebound Control Stop Kit, Axle Set, Consists of 4 Bumpers & 4 Stop Nuts (Eliminates Nut, Key No. 8)	
10	19114-000	5/8"-18 UNF Locknut	8	23		End Bushing Adapter Kit, One Wheel End	
11		*Saddle Assembly – 12¼" Height, Includes Key Nos. 5-6, 9-10 & 12-15	2		45000-013L	Use with End Bushing Key No. 18a – 5¼" Length	
	11480-003	34K			45000-007L	Use with End Bushing Key No. 18b – 5¾" Length	
	11480-015	38K		24		End Bushing Adapter Kit, One Wheel End, with Split Ring	
12		Saddle Cap	4		45000-014L	Use with End Bushing Key No. 18a – 5¼" Length	
	06662-000	34K			45000-008L	Use with End Bushing Key No. 18b – 5¾" Length	
	58795-000	38K, <i>Replaces 06612-000</i>		25	60218-000	**Torque Rod Assembly, <i>Replaces 32271-XXX</i>	2
13		7/8"-14 UNF/9 UNC Saddle Cap Stud	8	26	22186-000	Torque Rod Frame Bracket	2
	09029-000	34K			30286-000	*Adhesive Tube, EC-4475-3M (not shown)	1
	09030-000	38K					
14	22962-002	7/8" Hardened Washer	8				
15	04842-000	7/8"-14 UNF Saddle Cap Locknut	8				
16		Equalizing Beam Assembly <i>See Selection Guide 45745-147</i>	2				
17		Center Bushing	2				
	06664-000L	34K - with Welded Plug					
	22279-000L	34K - with Loose Plug					
	05919-000L	38K - with Welded Plug					
	22282-000L	38K - with Loose Plug					

NOTES: * No longer available. Contact Hendrickson to upgrade to a conversion.

** Hendrickson's part number is stamped on the torque rod for identification. Be sure to include the suffix number when ordering, this number indicates torque rod length.



■ Obsolete January 1989

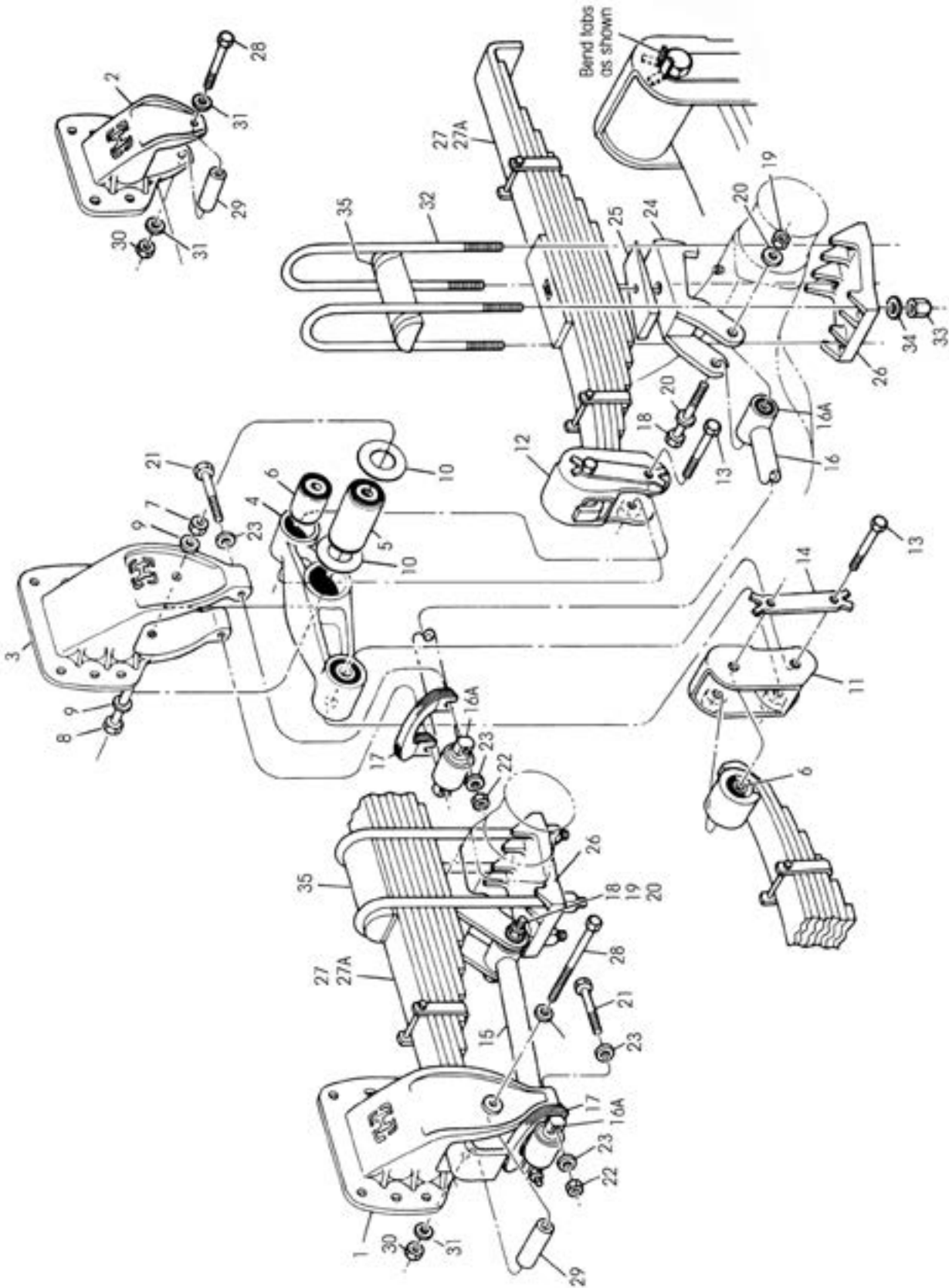



VEHICLE				VEHICLE			
KEY NO.	PART NO.	DESCRIPTION	QTY.	KEY NO.	PART NO.	DESCRIPTION	QTY.
1	47432-002	*Front Spring Hanger (Casting No. 47431-000)	2	22	30585-000	5/8"-1 1/4 UNC Torque Rod Mounting Nut (Hanger)	8
2	48530-004	*Rear Spring Hanger (Casting No. 48991-000) <i>Replaces 47436-003</i>	2	23	22962-004	5/8" Torque Rod Mounting Washer (Hanger)	16
3	56833-004	*Center Spring Hanger (Casting No. 47433-000) <i>Replaces 47434-002</i>	2	24		*Spring Seat	4
4	47444-001	*Equalizing Beam Assembly, Includes Key Nos. 5-6 (Casting No. 47437-000)	2		47973-000	Casting No. 47961-000, <i>Replaces 47716-000</i>	
5	47420-000	Center Bushing	2		47974-000	Casting No. 47962-000, <i>Replaces 47718-000</i>	
6	47421-000	End Bushing & Spring Eye Bushing	8	25		*Wedge	As Req.
7	08017-000	1" Center Bushing Locknut	2		47731-000	No Tab	
8	30550-035	1" Center Bushing Bolt, <i>Replaces 30550-033</i>	2		48053-000	2 Tab	
9	22962-006	1" Hardened Flat Washer	4		48054-000	3 Tab	
10	47416-000	Thrust Washer	4		48055-000	4 Tab	
11	47440-000	*Shackle Bracket		26		*Bottom Cap	4
12	47442-000	LF/RHR, (Casting No. 47439-000)	2		48252-000	<i>Replaces 47450-005 & 47965-000</i>	
13	48728-000	RHF/LHR (Casting No. 47441-000)	2		48254-000	<i>Replaces 47451-000, 47452-000, 47453-000,</i> <i>47454-000, 47963-000, 47964-000,</i> <i>47966-000, 48255-000, & 48096-000</i>	
14	47459-000	7/8"-9 UNC Shackle Bolt	8	27		Spring	4
15	48158-001	Shackle Bolt Retainer	4		50863-000	34K Capacity, <i>Replaces 47474-000</i>	
16	48158-002	Front Torque Rod - Shim Type Adjustable <i>Replaces 47401-001</i>	2		50865-000	38K Capacity, <i>Replaces 47475-000</i>	
	a	Torque Rod Bushing - Bar Pin Type	4	28	24531-014	1/2"-13 UNC x 5" Rebound Bolt	4
	b	Torque Rod Bushing - Thru-Bolt Type	4	29	57988-000	Rebound Bolt Spacer, <i>Replaces 47458-000</i>	4
17	49689-000L	Shim, <i>Replaces 47457-000</i>	As Req.	30	49846-000	1/2"-13 UNC Rebound Bolt Nut, <i>Replaces 46578-000</i>	4
18	30418-009	7/8"-1 1/4 UNF Torque Rod Mounting Bolt (Axle)	4	31	22962-014	1/2" Rebound Bolt Washer	8
19	80796-009	7/8"-1 1/4 UNF Torque Rod Mounting Locknut (Axle)	4	32		7/8" U-bolt	8
20	22962-002L	7/8" Torque Rod Mounting Washer (Axle)	8		47417-001	1 6/16"	
21	32043-005	5/8"-1 1/4 UNC Torque Rod Mounting Bolt (Hanger) <i>Replaces 30587-017</i>	8		47417-003	1 7/16"	
				33	50765-000	7/8"-1 1/4 UNF U-Bolt Locknut, <i>Replaces 23899-000</i>	16
				34	22962-002	7/8" Hardened Washer	16
				35	48797-000	Top Pad, <i>Replaces 47446-000</i>	4

NOTE: * No longer available. Contact Hendrickson to upgrade to a conversion.



■ Obsolete June 1996

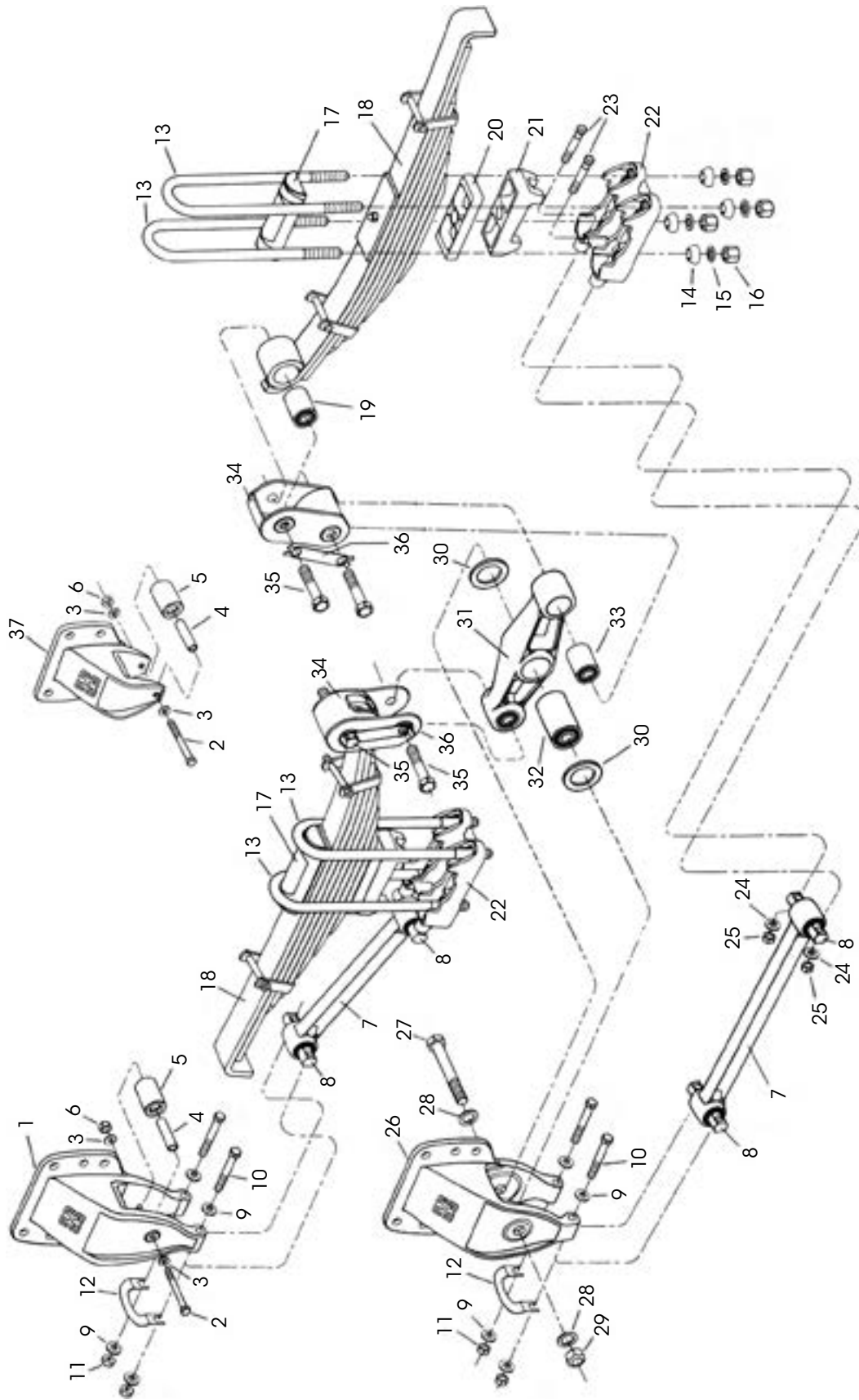



KEY NO.	PART NO.	DESCRIPTION	VEHICLE QTY.	KEY NO.	PART NO.	DESCRIPTION	VEHICLE QTY.
1		Front Spring Hanger	2			Rear Spring Seat	2
		*Casting No. 56829-001		56501-007		5° Pinion Angle, Casting No. 56500 <i>Replaces 49158-000 Casting No. 49157</i>	
	56830-002	For International, <i>Replaces 48533-002</i>		49124-000		*6.5° Pinion Angle, Casting No. 49143	
	56830-003	For Kenworth, <i>Replaces 48533-003</i>		49125-000		*9.5° Pinion Angle, Casting No. 48656,	
	56830-012	*For Manning Ford		56513-006		*10.5° Pinion Angle, Casting No. 48658, <i>Replaces 49126-000</i>	
	56886-002	*Casting No. 56885-00X For Mack, <i>Replaces 48533-006</i>		56505-009		12° Pinion Angle, Casting No. 56504 <i>Replaces 49127-000 Casting No. 48643</i>	
	56673-001	*Casting Nos. 56672-001, 47431-000, 47432-001, 48442-, 48533-001, 48533-002, 48533-003, 48533-004, 48533-005, 48533-006, 49047-000, 49050-001, 49723-000, 49726-001		22		Axle Bottom Cap, Includes Key Nos. 23-25 (Rockwell SL, SQ-100, RT 34-145, RT 40-145, Eaton D341, D402) 0-9° Pinion Angle, Casting No. 48810-000	
	49175-014	Rebound Roller Kit, Axle Set , Includes Key Nos. 2-6, <i>Replaces 49175-005</i>		49064-000		LHF/RHR	1 Each
2	24531-015	½"-13 UNC x 5½" Rebound Bolt	4	49134-000		*RHF (Casting No. 48811-000)	1
3	22962-014	½" Hardened Flat Washer	8	49135-000		*LHR (Casting No. 48812-000)	1
4	57988-000	Rebound Bolt Spacer, <i>Replaces 47458-000</i>	4			9.5-13° Pinion Angle	
5	57989-000	Rebound Roller, <i>Replaces 48883-000</i>	4	56857-000		LHR (Casting No. 56855-000) <i>Replaces 49138-000</i>	1
6	49846-000	½"-13 UNC Rebound Bolt Nut	4	56854-000		RHR (Casting No. 56852-000) <i>Replaces 49139-000</i>	1
7		Torque Rod Assembly - Shim Type Adjustable		23	49063-000	⅝"-11 UNC x 3⅞" Axle Cap Bolt	8
	48411-001	15.83" Front	2	24	22962-004	⅝" Hardened Flat Washer	8
	48411-002	*21.93" Rear	2	25	47764-000	⅝"-11 UNC Axle Cap Nut	8
8	47691-000L	Torque Rod Bushing	8	26		Center Spring Hanger	2
	49176-001L	Torque Rod Fastener Kit, Axle Set , Includes Key Nos. 9-11		56833-003		Casting No. 56832-000, <i>Replaces 47434-002</i> , <i>Casting Nos. 47433, 50642, 56926</i>	
9	22962-004	⅝" Hardened Flat Washer	16	49839-XXX		*Casting Nos. 48428-000, 50640-000, 56926-000 - Specify Customer	
10	32043-005	⅝"-11 UNC Torque Rod Bolt	8	27	30550-035	1" Center Bushing Bolt	2
11	47764-000	⅝"-11 UNC Torque Rod Nut	8	28	22962-006	1" Hardened Flat Washer	4
12	49689-000L	Torque Rod Shim	As Req.	29	08017-000	1" Center Bushing Locknut	2
13	47417-XXX	*U-bolt, Specify Length	8	30	47416-000	Thrust Washer	4
14	48574-000	Spherical Washer	16	31	47444-001	Equalizing Beam Assembly, Includes Key Nos. 33-34 (Casting No. 47437-000) 36K • 40K, <i>Replaces 47444-004</i>	2
15	22962-002	⅞" Hardened Flat Washer	16	32	47420-000	Center Bushing, <i>Replaces 48402-000</i>	2
16	50765-000	⅞"-14 UNF U-Bolt Locknut, <i>Replaces 23899-000</i>	16	33	47421-000	End Bushing, <i>Replaces 48401-000</i>	4
17		Top Pad	4	34		*Shackle Bracket	
	48797-000	Separate From Spring		47440-000		LHF/RHR (Casting No. 47439)	2
	50788-000	Part of Spring		47442-000		RHF/LHR (Casting No. 47441)	2
18		Spring Assembly	4	35	48728-000	⅞"-9 UNC Shackle Bolt	8
	50863-000	36K with Top Pad, <i>Replaces 47474-000</i>		36	47459-000	Shackle Bolt Retainer	4
	50865-000	40K with Top Pad, <i>Replaces 48400-000</i>		37		Rear Spring Hanger	2
19	47421-000	Spring Eye Bushing	4			Casting No. 48529-000 <i>Replaces 47436-003 Casting No. 48991</i> Specify Customer	
20		Spacer					
	48902-000	1"					
	48903-000	1½"					
21		Front Spring Seat	2				
	56509-001	*2.25° Pinion Angle, Casting No. 48657 <i>Replaces 49121-000</i>					
	50518-000	*3.25° Pinion Angle, Casting No. 48692 or 49122					
	49123-000	4° Pinion Angle, Casting No. 48630					
	56501-007	5° Pinion Angle, Casting No. 56500-000, <i>Replaces 49158-000 Casting 49157</i>					

NOTE: * No longer available. Contact Hendrickson to upgrade to a conversion.



■ Obsolete August 1995

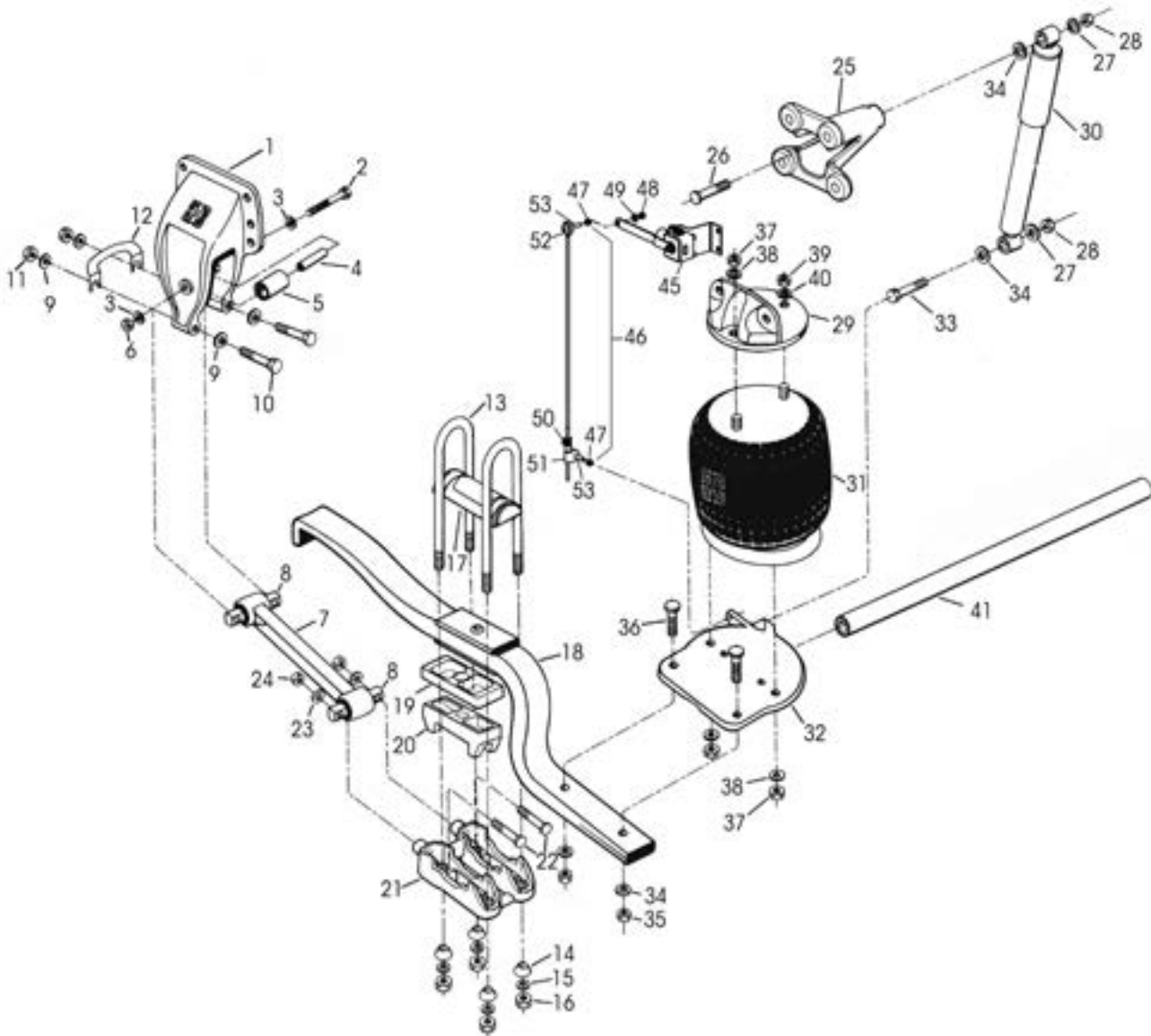

Height Control Valve Part No. 57977-000
and Linkage Assembly Part No. 58994-0XX

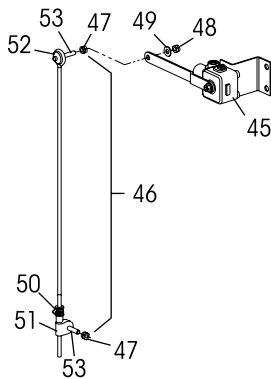

Transverse Torque Rod
Equipped with Straddle Bushings

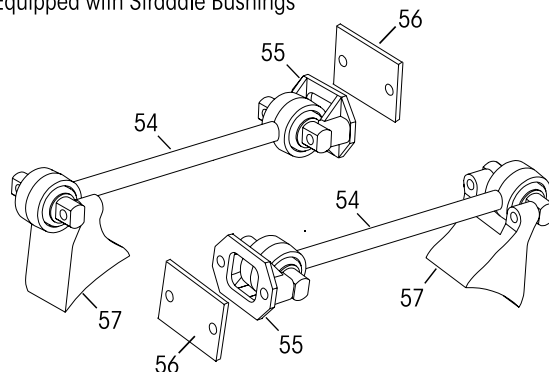



KEY NO.	PART NO.	DESCRIPTION	VEHICLE *QTY.	KEY NO.	PART NO.	DESCRIPTION	VEHICLE *QTY.
1	56673-001	Front Spring Hanger **Casting Nos. 56672-001, 49723-000 <i>Replaces Part No. 49726-001, 49047-000</i>	4	27	22962-031	½" Hardened Flat Washer	8
	56830-XXX	**Casting No. 56829-001 <i>Replaces Casting No. 48442-000 Replaces Part No. 48533-000</i>		28	49846-000	½"-13 UNC Shock Nut, <i>Replaces 49140-000</i>	8
	49175-014	Rebound Roller Kit, Axle Set, Includes Key Nos. 2-6		29	50804-002	Air Spring Frame Hanger, Casting No. 57455-000 <i>Replaces Casting No. 48152-000, Part No. 57456-000, 48159-000, 50804-001</i>	4
2	24531-015	½"-13 UNC x 5½" Rebound Bolt	4	30		Shock Absorber	4
3	22962-014	½" Hardened Flat Washer	8		60670-003L	Ford, <i>Replaces 47902-013</i>	
4	57988-000	Rebound Bolt Spacer	4		60670-001L	Mack, <i>Replaces 47902-009</i>	
5	57989-000	Rebound Roller	4		60670-003L	All Others, <i>Replaces 47902-008</i>	
6	49846-000	½"-13 UNC Rebound Bolt Nut	4	31		Air Spring	4
7		Torque Rod Assembly - Shim Type Adjustable HA 36K • 40K	4		50405-002L	Ford, <i>Replaces 50405-001</i>	
	48411-001	15.83"			49674-002	**Mack	
	62005-420	16.5", <i>Replaces 48411-003</i>			49048-002L	All Others, <i>Replaces 49207-000 and 49048-000</i>	
		HA 46K		32		Air Spring Bracket Assembly, Includes Key Nos. 33-36	
	62009-400	15.75", <i>Replaces 50376-002, 32271-098</i>			48908-001	Left Hand (Casting No. 48836-001)	2
	62005-420	16.54", <i>Replaces 50376-003, 32271-099</i>			48908-002	Right Hand (Casting No. 48836-002)	2
8		Torque Rod Bushing	8	33	50368-000	Shock Bolt, <i>Replaces 48752-000</i>	4
	47691-000L	36K • 40K - 62009 and 62005 Series		34	22962-001	¾" Hardened Flat Washer	16
	44695-000L	46K - 32271 Series		35	49842-000	¾"-10 UNC Main Support Member Nut <i>Replaces 49140-000</i>	8
	57256-000L	46K - 50376 Series		36	50369-000	¾"-10 UNC Main Support Member Bolt <i>Replaces 48829-000</i>	8
	49176-001L	Torque Rod Fastener Kit, Axle Set, Includes Key Nos. 9-11			49177-001	Air Spring Fastener Kit, Axle Set, Includes Key Nos. 37-40	
9	22962-004	⅝" Hardened Flat Washer	16	37	17700-010	½" Nut	12
10	32043-005	⅝"-11 UNC Torque Rod Bolt	8	38	22962-014	½" Hardened Flat Washer	12
11	47764-000	⅝"-11 UNC Torque Rod Nut	8	39	17700-031	¾" Nut	4
12	49689-000L	Torque Rod Shim	As Req.	40	22962-001	¾" Hardened Flat Washer	4
	48718-XXX	U-bolt Assembly, Includes Key Nos. 13-16		41	44642-022	Cross Tube	2
13	47417-XXX	U-bolt, Specify Length	8		48689-001	Quick Release Kit, Includes Key Nos. 42-43	
14	48574-000	Spherical Washer	16	42	66029-000	***Air Dump Switch (Located In Cab) <i>Replaces Part No. 48914-000</i>	1
15	22962-002	7/8" Hardened Flat Washer	16	43	48940-000	***Air Switch Name Plate, (Located In Cab)	1
16	50765-000	7/8"-14 UNF U-Bolt Locknut <i>Replaces 23899-000</i>	16	44	30272-000	***Pressure Protection Valve	1
17	49337-000	**Top Pad, <i>Replaces 48797-000</i>	4	45	57977-000	Height Control Valve <i>Replaces 50433-001/002, 49193-001</i>	1
18		Main Support Member	4	46	58994-0XX	Linkage Rod, Specify Length, Includes Key Nos. 47-53, <i>Replaces 58400-, 22107-</i>	1
	48112-001	36K (1⅝")		47		****⅝"-18 UNC Jam Nut	2
	56871-001	40K (1⅞") <i>Replaces 48874-001</i>		48		****⅝"-18 UNC Locknut	2
	48645-001	46K (2⅜") <i>Replaces 48645-000</i>		49		****⅝" Hardened Washer	2
19		Spacer	As Req.	50		****Valve Arm Clamp	1
	48902-000	1"		51		****Adj. Valve Arm Joint	1
	48903-000	1½"		52		****Rubber Grommet	1
20		Spring Seat, <i>See Table on Page 12</i>		53		****Valve Arm Joint	2
21		Axle Bottom Cap, <i>See Table on Page 13</i> Includes Key Nos. 22-24	1	54		Transverse Torque Rod Assembly	2
22	49063-000	⅝"-11 UNC x 3⅞" Axle Cap Bolt	8		60218-000	36K • 40K, <i>Replaces 52271-000</i>	
23	22962-004	⅝" Hardened Flat Washer	8		60215-000	46K, <i>Replaces 50234-000a</i>	
24	47764-000	⅝"-11 UNC Axle Cap Nut	8	55	22186-000	Torque Rod Frame Bracket	2
25	48924-000	Shock Frame Hanger, Casting No. 48906-000 Includes Key Nos. 26-28	4	56	45045-010	Backup Plate, <i>Replaces 45045-003</i>	2
26	50368-000	½"-13 UNC Shock Bolt, <i>Replaces 48752-000</i>	4	57		Torque Rod Axle Bracket	2

NOTES: * Quantities specified are shown for tandem suspension.
 ** No longer available. Contact Hendrickson to upgrade to a conversion.
 *** See Plumbing Diagram on Page 13.
 **** Item included in kit/assembly only, part not sold separately.

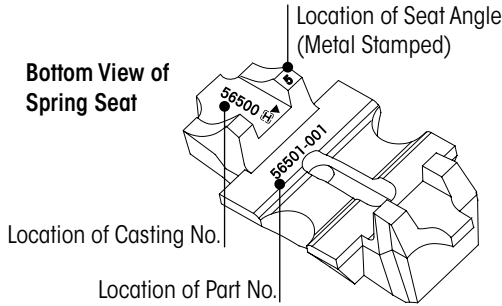

***ALL HA 46K SPRING SEATS**

NOTE: All HA 46K spring seats are no longer available. Contact Hendrickson to convert to upgrade to a conversion.

****HA 36K • 40K SPRING SEATS SELECTION GUIDE**

Key No. 20	**HA 36K • 40K SPRING SEATS SELECTION GUIDE				
	LEFT		RIGHT		
FRONT	Eaton D341, D402, D404, D405 Rockwell RT40-145, SQ100		Eaton D404, D405 Rockwell RT40-145	Eaton D461, D402 Rockwell SQ100	
CASTING NO.	56500-000		56500-000	*56502-000	
SEAT ANGLE	PART NO.	NO.REQ.	PART NO.	PART NO.	NO.REQ.
2°	56501-001	1	56501-001	*56503-001	1
2½°	56501-002	1	56501-002	*56503-002	1
3°	56501-003	1	56501-003	*56503-003	1
3½°	56501-004	1	56501-004	*56503-004	1
4°	56501-005	1	56501-005	*56503-005	1
4½°	56501-006	1	56501-006	*56503-006	1
5°	56501-007	1	56501-007	*56503-007	1
5½°	56501-008	1	56501-008	*56503-008	1
6°	56501-009	1	56501-009	*56503-009	1
6½°	56501-010	1	56501-010	*56503-010	1
7°	56501-011	1	56501-011	*56503-011	1
REAR	LEFT		RIGHT		
	Eaton D404, D405 Rockwell RT40-145	Eaton D341, D402 Rockwell SQ100		Eaton D341, D402, D404, D405 Rockwell RT40-145, SQ100	
CASTING NO.	56504-000	*56506-000		56500-000	
SEAT ANGLE	PART NO.	PART NO.	NO.REQ.	PART NO.	NO.REQ.
5°	56505-011	*56507-011	1	56501-011	1
6½°	56505-012	*56507-012	1	56501-012	1
7½°	56505-018	*56507-016	1	56501-018	1
8°	56505-001	*56507-001	1	56501-001	1
8½°	56505-002	*56507-002	1	56501-002	1
9°	56505-003	*56507-003	1	56501-003	1
9½°	56505-004	*56507-004	1	56501-004	1
10°	56505-005	*56507-005	1	56501-005	1
10½°	56505-006	*56507-006	1	56501-006	1
11°	56505-007	*56507-007	1	56501-007	1
11½°	56505-008	*56507-008	1	56501-008	1
12°	56505-009	*56507-009	1	56501-009	1
12½°	56505-010	*56507-010	1	56501-010	1
13½°	56505-015		1	56501-015	1

* No longer available. Contact Hendrickson to upgrade to a conversion.

** Four (4) spring seats required per tandem suspension



Key No. 21		HA 36K • 40K • 46K AXLE BOTTOM CAP SELECTION GUIDE				
FRONT	LEFT			RIGHT		
	Rockwell SL, SQ-100, RT 34-145, RT 40-145, RT 46-160, SSHD Eaton D341, D402, D461	Rockwell SL, SQ-100, RT 34-145, RT 40-145	Rockwell SL, SQ-100, RT 34-145, RT 40-145	Eaton D341, D402	Eaton D461	Rockwell SL, SQ-100, RT 34-145, RT 40-145, SSHD Eaton D341, D402
CASTING NO.	48810-000	48812-000	56855-000	48810-000	48811-000	56852-000
PINION ANGLE	PART NO.	PART NO.	PART NO.	PART NO.	PART NO.	PART NO.
0-5°	48390-000			48391-000		
0-9°	49064-000	*49135-000			*49134-000	
0-9½°	49064-000				*49659-000	
9½-13°			56857-000			56854-000
REAR	LEFT			RIGHT		
	Rockwell RT 46-160 Eaton D461	Rockwell SSHD	Eaton D461	Rockwell SSHD	Rockwell SL, SQ-100, RT 34-145, RT 40-145, RT 46-160, SSHD Eaton D341, D402, D461	Rockwell RT 46-160, SSHD Eaton D461
CASTING NO.	48810-000	48812-000	56852-000	56855-000	48810-000	56852-000
PINION ANGLE	PART NO.	PART NO.	PART NO.	PART NO.	PART NO.	PART NO.
0-5°	50367-000				48390-000	
0-9°					49064-000	
0-9½°		*49660-000			49064-000	
6½-12°			56944-000			57219-000
10-12°				56945-000		56854-000

* No longer available. Contact Hendrickson to upgrade to a conversion.

■ HA 36K • 40K • 46K PLUMBING DIAGRAM

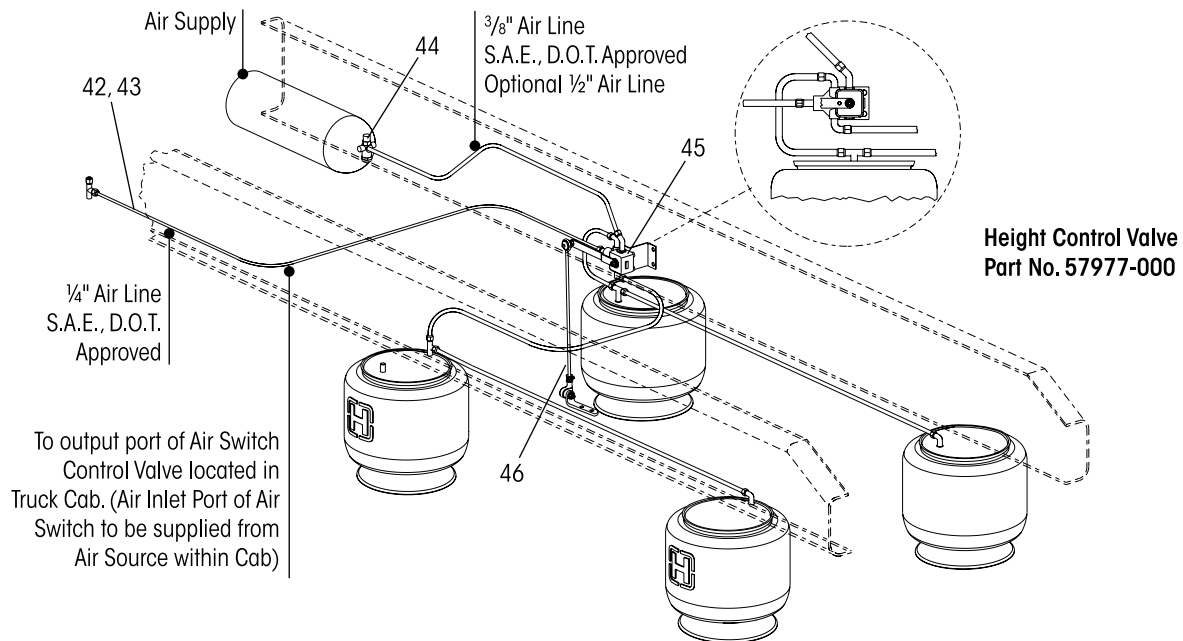

■ Obsolete 2004

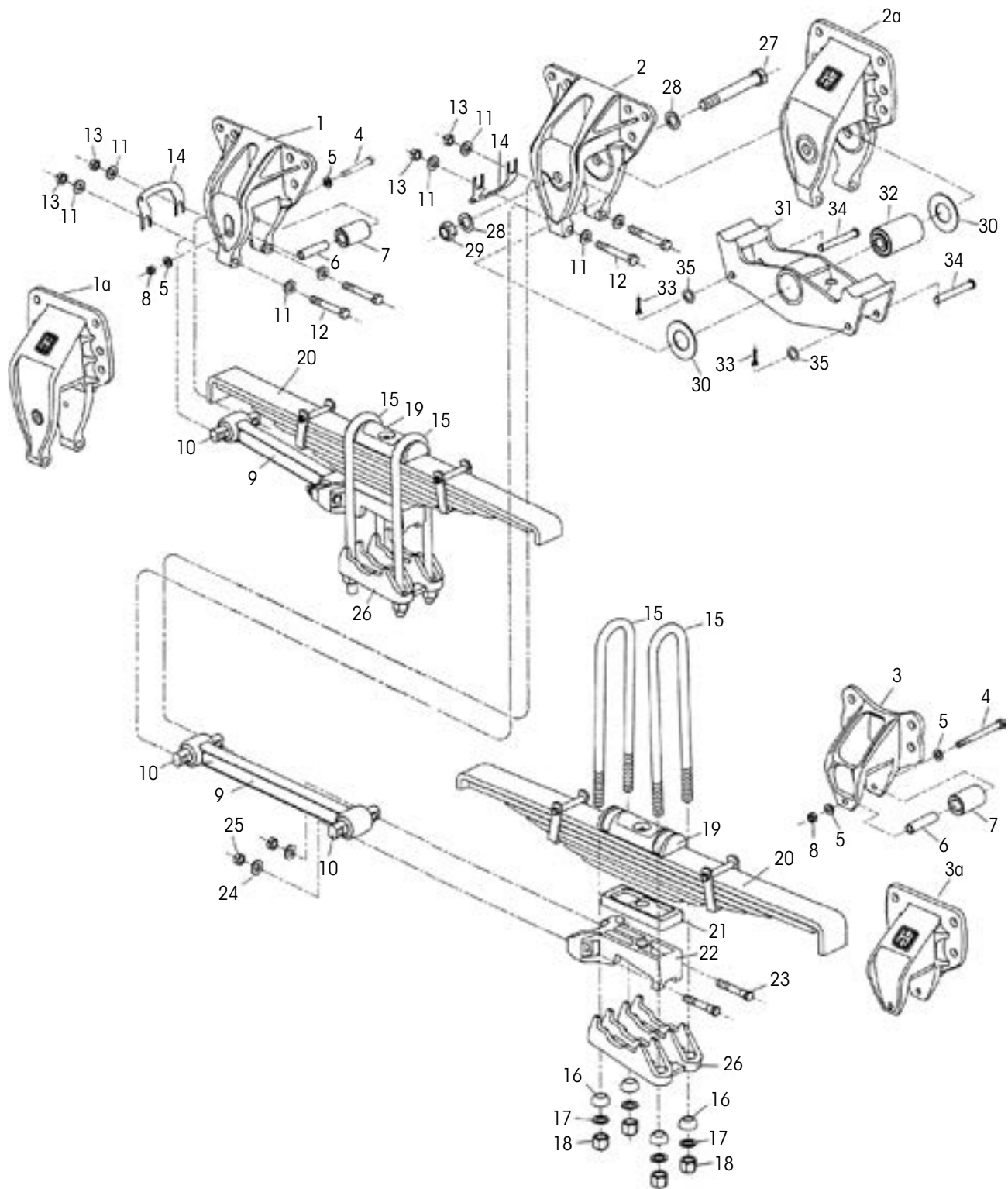



			VEHICLE				VEHICLE
KEY NO.	PART NO.	DESCRIPTION	QTY.	KEY NO.	PART NO.	DESCRIPTION	QTY.
1		Front Spring Hanger	2		50795-000	HFS 36K • 40K LH	
	56667-001	*Casting No. 56666-000, 49848-000, <i>Replaces 50027-001 - HFS 36K</i>			50796-000	HFS 40K	
	56670-001	Casting No. 56669-000, 50291-000, <i>Replaces 50292-001 - HFS 40K • 40K LH</i>		21		Spacer	As Req.
a	56673-001	*Casting No. 56672-000	2		48902-000	1"	
	56830-XXX	*Casting No. 56829-000			48903-000	1½"	
2		Center Spring Hanger	2	22		*Spring Seat Includes Key Nos. 23-25 (Rockwell SL, SQ-100, RT34-145, RT40-145, Eaton D341, D402)	4
	56676-001	Casting No. 56675-000, 50289-000, <i>Replaces 50290-001</i>				*Casting No. 50567-000	
a	56927-004	*Casting No. 56832-000, <i>Replaces 56833-003</i>	2		50569-001	2¼° Pinion Angle	
	56927-XXX	*Casting No. 56926-000, Specify Customer			50569-004	3¼° Pinion Angle	
3		Rear Spring Hanger	2		50569-007	4° Pinion Angle	
	50028-001	Casting No. 49954-001, <i>Replaces 49954-000</i>			50569-010	5° Pinion Angle	
a	48530-004	*Casting No. 48991-000, <i>Replaces 47436-003</i>	2			*Casting No. 50573-000	
	48530-XXX	Casting No. 48529-000, Specify Customer			50575-001	9½° Pinion Angle	
	49175-014	Rebound Roller Kit , Includes Key Nos. 4-8 <i>Replaces 49175-005</i>	1		50575-004	10½° Pinion Angle	
4	24531-015	½"-13 UNC Rebound Bolt	4		50575-009	12° Pinion Angle	
5	22962-014	½" Hardened Flat Washer	8	23	49063-000	⅝"-11 UNC Spring Seat Bolt	8
6	57988-000	Rebound Bolt Spacer, <i>Replaces 47458-000</i>	4	24	22962-004	⅝" Hardened Flat Washer	8
7	57989-000	Rebound Roller, <i>Replaces 48883-000</i>	4	25	47764-000	⅝"-11 UNC Axle Cap Nut	8
8	49846-000	½"-13 UNC Rebound Bolt Nut, <i>Replaces 46578-000</i>	4	26		Axle Bottom Cap	4
9		Shim Type Adjustable Torque Rod Assembly				(Rockwell RT34-145, RT40-145)	
	48411-006	14.41" Front			93302-XXX	LHF/RHF/LHR/RHR 0-9½° Pinion Angle, <i>Replaces 50216-XXX</i>	
	62011-515	20.31" Rear, <i>Replaces 48411-007</i>			93315-XXX	LHR/RHR 10-12½° Pinion Angle, <i>Replaces 50222-XXX</i>	
10	47691-000L	Torque Rod Bushing	8		93302-XXX	(Rockwell SL-100, SQ-100, Eaton D341, D402) LHF/RHR 0-9½° Pinion Angle, <i>Replaces 50216-XXX</i>	
	49176-001L	Torque Rod Fastener Kit , Includes Key Nos. 11-13	1		50217-XXX	RHF 0-9½° Pinion Angle	
11	22962-004	⅝" Hardened Flat Washer	16		93315-XXX	LHR 0-9½° Pinion Angle, <i>Replaces 50218-000, 50222-XXX</i>	
12	32043-005	⅝" -11 UNC x 4½" Torque Rod Bolt	8			RHR 10-12½° Pinion Angle	
13	47764-000	⅝" -11 UNC Torque Rod Nut	8		93315-XXX	*LHR 10-12½° Pinion Angle, <i>Replaces 50221-000, 50222-XXX</i>	
14	49689-000	Torque Rod Shim	As Req.	27	30550-035	1" Center Bushing Bolt	2
15		U-bolt (Specify Length)	8	28	22962-006	1" Hardened Flat Washer	4
	49684-XXX	¾" - HFS 40K LH		29	08017-000	1" Center Bushing Nut	2
	47417-XXX	⅞" - HFS 36K • 40K		30	47416-000	Thrust Washer	4
16		Spherical Washer	16	31	49803-002	Equalizing Beam Assembly, Includes Key Nos. 32-35, Casting No. 49801-002, <i>Replaces 49803-003</i>	2
	49947-000	¾" - HFS 40K LH				Center Bushing, <i>Replaces 48402-000</i>	
	48574-000	⅞" - HFS 36K • 40K		32	47420-000	Center Bushing, <i>Replaces 48402-000</i>	2
17		Hardened Flat Washer	16	33	17800-013	Cotter Pin	4
	22962-001	¾" - HFS 40K LH		34	50432-000	Clevis Pin	4
	22962-002	⅞" - HFS 36K • 40K		35	50924-000	⅝" Hardened Washer	4
18		U-bolt Locknut	16				
	49685-000	¾" - HFS 40K LH					
	50765-000	⅞" - HFS 36K • 40K					
19	50788-000	Top Pad, Included with Key No. 20	4				
20		Spring Assembly	4				

NOTE: * No longer available. Contact Hendrickson to upgrade to a conversion.

■ Vehicles built BETWEEN March 1996 and September 1997

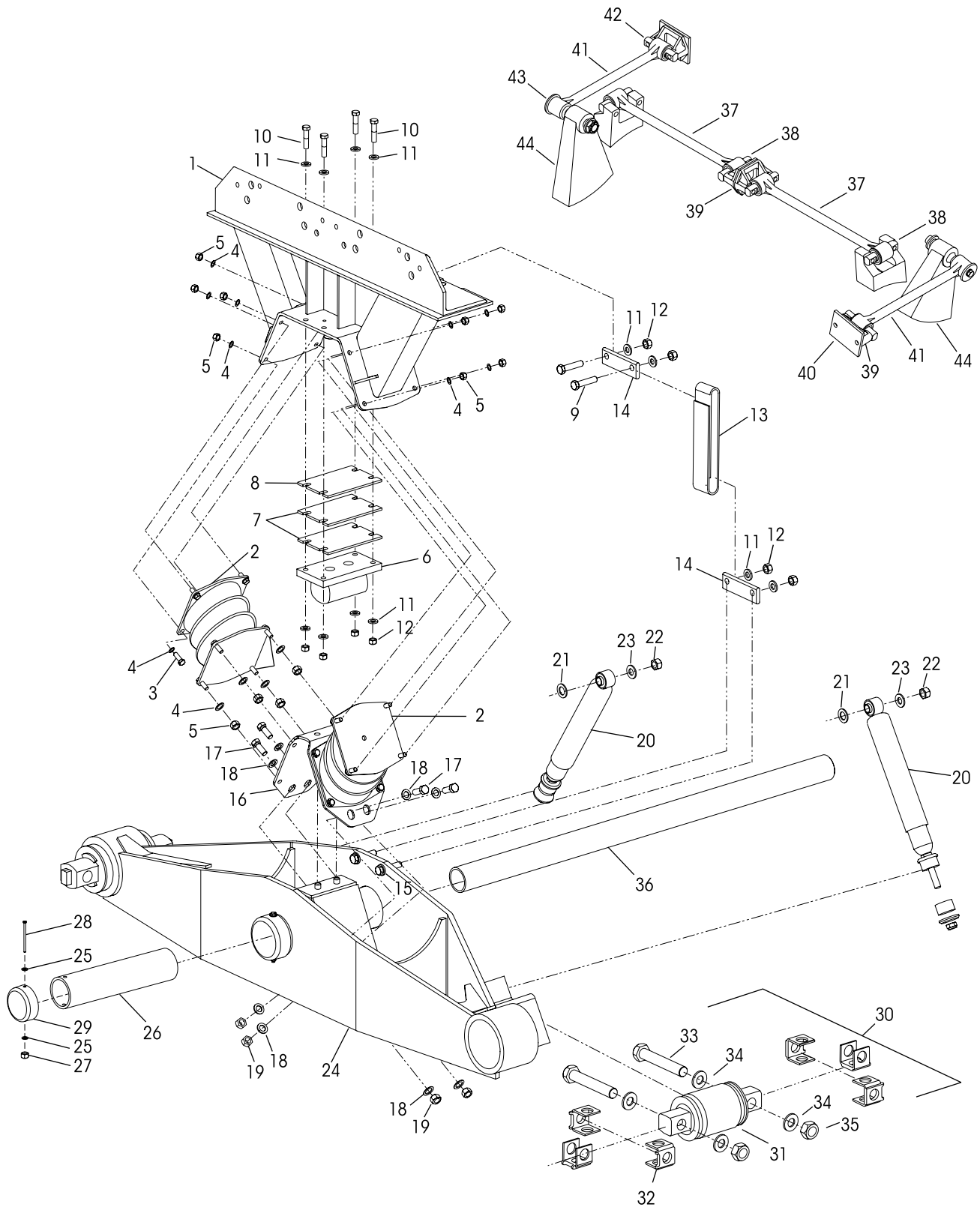



KEY NO.	PART NO.	DESCRIPTION	VEHICLE QTY.	KEY NO.	PART NO.	DESCRIPTION	VEHICLE QTY.
1	58223-0XX	*Saddle Assembly, Includes Key Nos. 2-12, 14, 16	2	25	22962-028	¼" Washer	4
2	60879-000L	Bolster Spring Kit, One Set (2-piece)	2	26	49972-000	Nylon Bushing	2
3	25114-011	7/16"-20 UNF x 1 ¼" Bolt	32	27	49983-000	¼"-20 UNC Locknut	2
4	22962-027	7/16" Hardened Washer	64	28	50698-000	¼"-20 UNC x 4 ½" Bolt	2
5	48949-000	7/16"-20 UNF Locknut	32	29	56910-000	Center End Cap	2
6	57962-000	Auxiliary Spring Assembly	2	30		Bar Pin End Bushing Service Kit, One Wheel End, Includes Key Nos. 31-35	
7	57993-002	Auxiliary Spring Shim	4		34013-088L	Shim Type	
8	57993-003	Auxiliary Spring Shim	6		34013-188L	Rotating, Shim Type	
9	24531-018	½"-13 UNC x 1 ¾" Bolt	4	31		**Bar Pin End Bushing	4
10	24531-008	½"-13 UNC x 2 ¾" Bolt, <i>Replaces 24531-019</i>	8	32		Bar Pin Shim	8
11	22962-014	½" Hardened Washer	40		50130-000	0.19" /0.19"	
12	49846-000	½"-13 UNC Locknut	16		50131-000	0.25"/0.12"	
13	57878-003	Rebound Strap	2	33	48941-000	1"-8 UNC x 6" Hex Bolt	4
14	57787-000	*Anchor Plate	4	34	22962-008	1" Hardened Washer	8
15	24531-017	½"-13 UNC x 2 ¼" Bolt	4	35	48942-000	1"-8 UNC Locknut	4
16	57461-000	Saddle Vee Bracket	2	36	44643-011	Cross Tube	1
	58440-001	Vee Bracket Fastener Kit, One Side, Includes Key Nos. 17-19		37	60218-000	**** Two-Piece ULTRA ROD® Longitudinal Torque Rod Straddle/Straddle Kit, Includes Key No. 38	
17	50764-006	¾"-10 UNC-2A Hex Head Bolt	8	38	47691-000L	ULTRA ROD Straddle Bushing	4
18	22962-001	¾" Washer	16	39	22186-000	Torque Rod Frame Bracket	4
19	49842-000	¾"-10 UNC-2B Locknut	8	40	45045-010	Backup Plate, <i>Replaces 45045-003</i>	2
20	60680-003L	Shock Absorber	4	41	60215-000	***** Two-Piece ULTRA ROD Transverse Torque Rod Straddle/Taper Kit, Includes Key No. 42-43	
21	22962-001	¾" Washer	4	42	47691-000L	ULTRA ROD Straddle Bushing	2
22	30585-000	5/8" Upper Shock Locknut	4	43	64697-000L	ULTRA ROD Taper Bushing	2
23	22962-004	5/8" Upper Shock Washer	4	44		***Transverse Rod Axle Bracket	2
24	58227-	*Beam Assembly, Specify Length, Includes Key Nos. 11-15, 25-31	2				

NOTES: * No longer available. Contact Hendrickson to upgrade to a conversion.

** Item included in kit/assembly only, part not sold separately.

*** Not supplied by Hendrickson, used for reference only. Hendrickson is not responsible for components supplied by the vehicle manufacturer. For assistance with maintenance and rebuild instructions on these components see vehicle manufacturer.

**** Hendrickson's part number is stamped on the rod for identification. Be sure and include suffix number when ordering, this number indicates rod length. The Hendrickson two-piece ULTRA RODS® can be used to create the desired length, see Torque Rod Selection Guide Literature No. 45745-148.

***** Transverse rods are mandatory for HN Suspension regardless of axle spacing. See Literature No. 59310-004 and 59310-058 for more information.

■ Obsolete February 1996

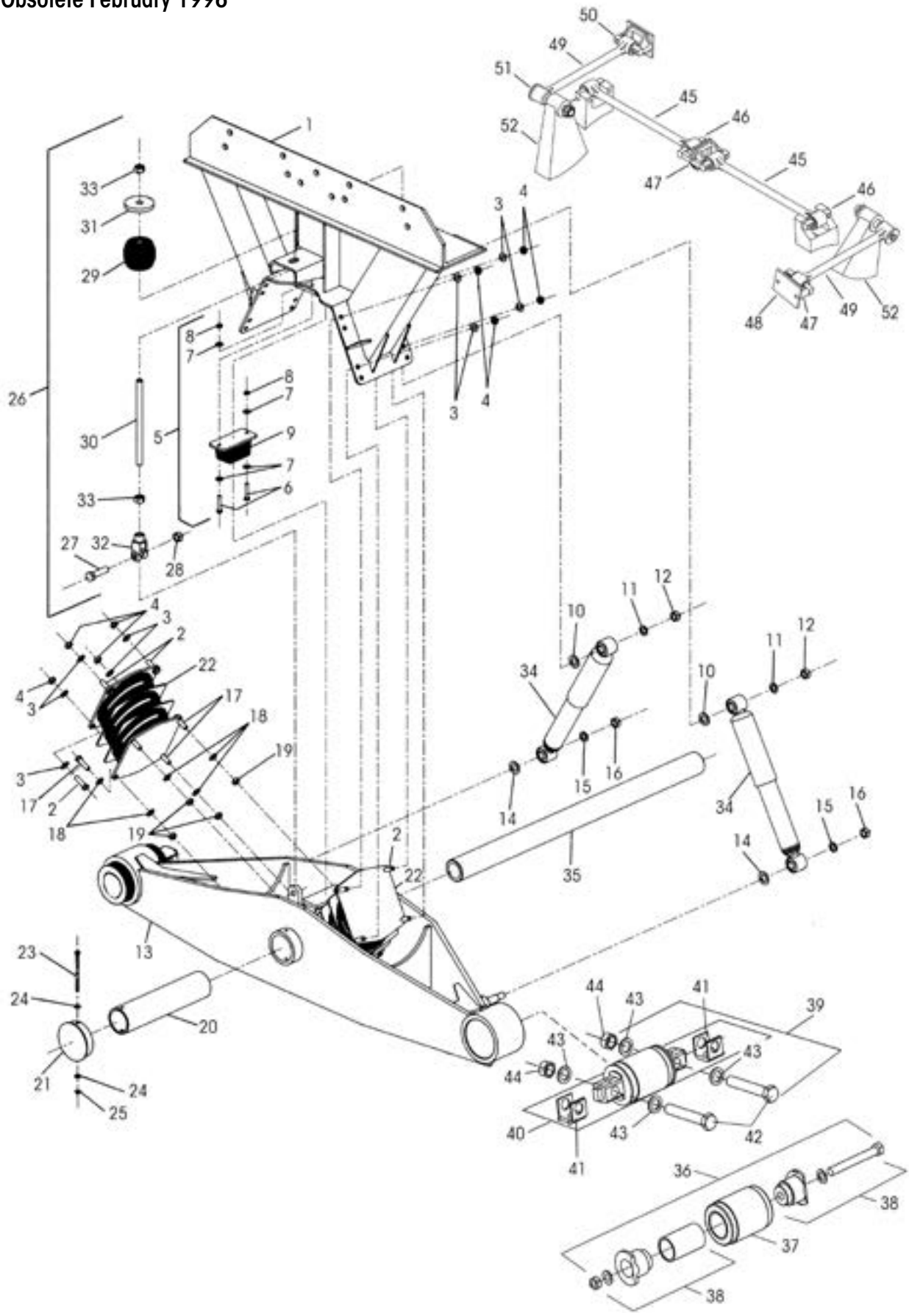



KEY NO.	PART NO.	DESCRIPTION	VEHICLE QTY.	KEY NO.	PART NO.	DESCRIPTION	VEHICLE QTY.
1	50787-0XX	*Saddle Assembly, Includes Key Nos. 2-4, 6-9	2	32	49771-000	Clevis	2
2	25114-011	7/16" Bolt	16	33	49778-000	5/8" Hex Nut	4
3	22962-027	7/16" Washer	32	34	60670-002L	Shock Absorber	4
4	48949-000	7/16" Locknut	16	35	44643-011	Cross Tube	1
5	49399-000	Rebound Rubber Stop Kit, One Side, Includes Key Nos. 6-9		36		Thru-Bolt Bushing Kit, One Wheel End, Includes Key Nos. 37-38	
6	18160-011	5/16" Bolt	4		34013-049L	HN 40K	
7	22962-029	5/16" Washer	8		34013-073L	HN 46K	
8	48948-000	5/16" Locknut	4	37	45900-000L	Bushing	4
9	49395-000	Rebound Rubber Stop	2	38		Adapter Kit, One Wheel End	4
10	22962-001	3/4" Inner Washer	4		45000-007L	HN 40K	
11	22962-004	5/8" Outer Washer	4		21140-034L	HN 46K	
12	30585-000	5/8" Locknut	4	39		Bar Pin End Bushing Service Kit, One Wheel End, Includes Key Nos. 40-44	
13	49976-XXX	*Beam Assembly, Specify Length, Includes Key Nos. 17-25, 36 or 39	2		34013-088L	Shim Type	
14	22962-001	3/4" Inner Washer	4		34013-188L	Rotating, Shim Type	
15	22962-004	5/8" Outer Washer	4	40		*Bar Pin End Bushing	4
16	30585-000	5/8" Locknut	4	41		Bar Pin Shim	8
17	25114-011	7/16" Bolt	16		50130-000	0.19"/0.19"	
18	22962-027	7/16" Washer	32		50131-000	0.25"/0.12"	
19	48949-000	7/16" Locknut	16	42	48941-000	1"-8 UNC x 6" Hex Bolt	4
20	49972-000	Nylon Bushing	2	43	22962-008	1" Hardened Washer	8
21	56910-000	End Cap	2	44	48942-000	1"-8 UNC Locknut	4
22	64718-000L	Bolster Springs (2-piece)	2	45	60218-000	**** Two-Piece ULTRA ROD® Longitudinal Torque Rod Straddle/Straddle Kit, Includes Key No. 46	
23	50698-000	1/4" Bolt	2	46	47691-000L	ULTRA ROD Straddle Bushing	4
24	22962-028	1/4" Washer	4	47	22186-000	Torque Rod Frame Bracket	4
25	49983-000	1/4" Locknut	2	48	45045-010	Backup Plate, <i>Replaces 45045-003</i>	2
26	49768-000	Rebound Control Kit, One Side, Includes Key Nos. 27-33		49	60215-000	***** Two-Piece ULTRA ROD Transverse Torque Rod Straddle/Taper Kit, Includes Key No. 50-51	
27	32043-004	5/8" Bolt	2	50	47691-000L	ULTRA ROD Straddle Bushing	2
28	47764-000	5/8" Locknut	2	51	64697-000L	ULTRA ROD Taper Bushing	2
29	48570-000	Rebound Control Spring	2	52		***Transverse Rod Axle Bracket	2
30	49769-000	Anti-Roll Rod	2				
31	49770-000	Threaded Washer	2				

NOTES: * No longer available. Contact Hendrickson to upgrade to a conversion.

** Item included in kit/assembly only, part not sold separately.

*** Not supplied by Hendrickson, used for reference only. Hendrickson is not responsible for components supplied by the vehicle manufacturer. For assistance with maintenance and rebuild instructions on these components see vehicle manufacturer.

**** Hendrickson's part number is stamped on the rod for identification. Be sure and include suffix number when ordering, this number indicates rod length. Hendrickson two-piece ULTRA RODS® can be used to create the desired length, see Torque Rod Selection Guide 45745-148.

***** Transverse rods are mandatory for HN Suspensions regardless of axle spacing. See Literature No. 59310-004 and 59310-058 for more information.



■ Obsolete January 1989

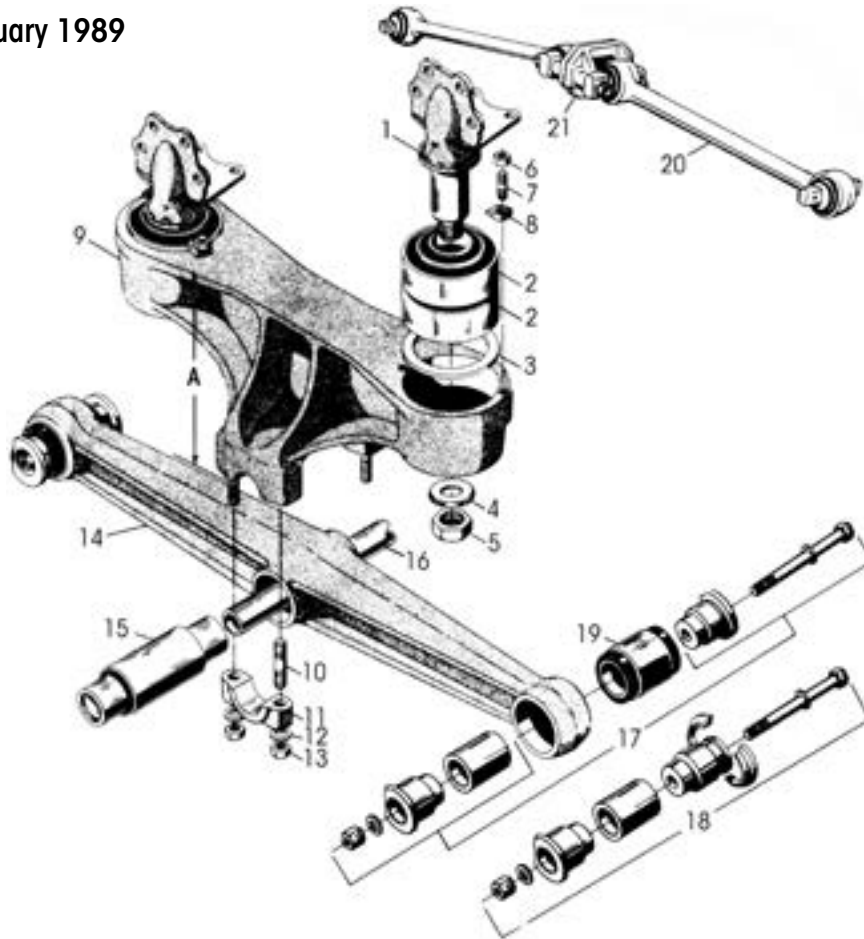

KEY NO.	PART NO.	DESCRIPTION	VEHICLE QTY.
1	23217-013	*Frame Hanger, Undrilled, Includes Key Nos. 4-5 (Casting No. 21283-001)	4
2	15137-000	*Shear Spring	8
3	21278-000	Spacer Ring	4
4	21037-000	*Washer	4
5	25151-000	1½"-12 UNF Locknut	4
6	19114-000	⅝"-18 UNF Locknut	8
7	19111-001	⅝"-18 UNF Stud, <i>Replaces 19111-005</i>	8
8	21297-000	*Clamp	8
9		*Saddle Assembly - Dim. A, Includes Key Nos. 2-3, 6-8 & 10-13	2
	18760-003	34K - 12⅞" Height	
	18760-011	34K - 13¾" Height	
	18760-005	38K - 12⅞" Height	
	18760-013	38K - 13¾" Height	
10		⅞"-14 UNF/9 UNC Saddle Cap Stud	8
	09029-000	34K	
	09030-000	38K	
11		Saddle Cap	4
	06662-000	34K	
	58795-000	38K, <i>Replaces 48545-000, 06612-000</i>	
12	22962-002	⅞" Hardened Washer	8
13	04842-000	⅞"-14 UNF Saddle Cap Locknut	8

KEY NO.	PART NO.	DESCRIPTION	VEHICLE QTY.
14		Equalizing Beam Assembly <i>See Selection Guide 45745-147</i>	2
15		Center Bushing	2
	06664-000L	34K - with Welded Plug	
	22279-000L	34K - with Loose Plug	
	05919-000L	38K - with Welded Plug	
	22282-000L	38K - with Loose Plug	
16		Cross Tube - 44⅞" Length	1
	44642-008L	34K	
	44643-009L	38K	
17		End Bushing Adapter Kit, One Wheel End,	
	45000-013L	5¼" Length, Includes Key No. 19a	
	45000-007L	5¾" Length, Includes Key No. 19b	
18		End Bushing Adapter Kit, One Wheel End, with Split Ring	
	45000-014L	5¼" Length, Includes Key No. 19a	
	45000-008L	5¾" Length, Includes Key No. 19b	
19		End Bushing	4
a	06969-000L	34K - 5¼" Length	
b	45900-000L	34K • 38K - 5¾" Length	
20	60218-000	**Two-Piece ULTRA ROD® Longitudinal Torque Rod Straddle/Straddle Kit, <i>Replaces 32271-XXX</i>	2
21	22186-000	Torque Rod Frame Bracket	2

NOTES: * No longer available. Contact Hendrickson to upgrade to a conversion.

** Hendrickson's part number is stamped on the rod for identification. Be sure and include suffix number when ordering, this number indicates rod length. Hendrickson two-piece ULTRA RODS® can be used to create the desired length, see Torque Rod Selection Guide 45745-148.



■ Obsolete January 1989

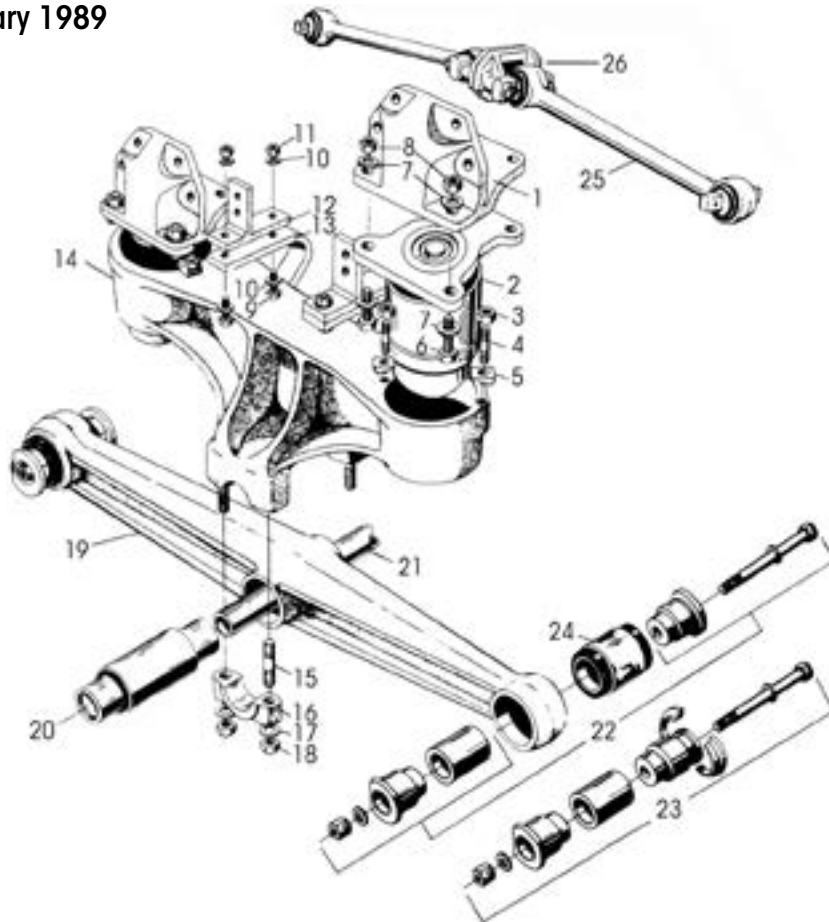

KEY NO.	PART NO.	DESCRIPTION	VEHICLE QTY.	KEY NO.	PART NO.	DESCRIPTION	VEHICLE QTY.
1		*Frame Hanger, Drilled (Casting No. 46205-000)	4	16		Saddle Cap	4
	46202-001	Fits Frame Width 34"			06662-000	34K	
	46202-002	Fits Frame Width 34.12"			58795-000	38K, Replaces 48545-000, 06612-000	
	46202-003	Fits Frame Width 34.25"		17	22962-002	7/8" Hardened Washer	8
	46202-004	Fits Frame Width 34.38"		18	04842-000	7/8"-14 UNF Locknut	8
	46202-005	Fits Frame Width 34.5"		19		Equalizing Beam Assembly See Selection Guide 45745-147	
	46202-006	Fits Frame Width 34.62"		20		Center Bushing	2
	46202-007	Fits Frame Width 34.81"			06664-000L	34K - with Welded Plug	
2		*V4 Visco Elastic Module	4		22279-000L	34K - with Loose Plug	
	47585-075	34K			05919-000L	38K - with Welded Plug	
	47585-085	38K			22282-000L	38K - with Loose Plug	
3	19114-000	5/8"-18 UNF Locknut	16	21		Cross Tube - 44 7/8" Length	1
4	19111-001	5/8"-18 UNF Stud	16		44642-008L	34K	
5	21297-000	*Clamp	16		44643-009L	38K	
6	21867-038	*3/4"-16 UNF Hex Bolt	16	22		End Bushing Adapter Kit, One Wheel End	
7	22962-001	3/4" Hardened Washer	32		45000-013L	5 1/4" Length, Includes Key No. 24a	
8	30191-000	3/4"-16 UNF Locknut	8		45000-007L	5 3/4" Length, Includes Key No. 24b	
9	30970-007	1/2"-20 UNF Hex Bolt	8	23		End Bushing Adapter Kit, One Wheel End, with Split Ring	
10	22962-011	1/2" Hardened Washer	8		45000-014L	5 1/4" Length, Includes Key No. 24a	
11	30978-000	1/2"-20 UNF Locknut	8		45000-008L	5 3/4" Length, Includes Key No. 24b	
12	46970-002	*Jounce Stop Hanger	4	24		End Bushing	4
13	46210-000	*Rebound Stop	4	a	06969-000L	34K - 5 1/4" Length	
14		*Saddle Assembly	2	b	45900-000L	34K • 38K - 5 3/4" Length	
	47680-001	34K - 12 7/8" Height		25	60218-000	**Two-Piece ULTRA ROD® Longitudinal Torque Rod Straddle/Straddle Kit, Replaces 32271-XXX	2
	47680-002	34K - 13 3/4" Height		26	22186-000	Torque Rod Frame Bracket	2
	47680-005	38K - 12 7/8" Height					
	47680-006	38K - 13 3/4" Height					
15		7/8"-14 UNF/9 UNC Saddle Cap Stud	8				
	09029-000	34K					
	09030-000	38K					

QUIK-ALIGN PIVOT BUSHING SERVICE TOOLS

Hendrickson Part No. 66086-202

OTC Part No. 4246 Visit otctools.com

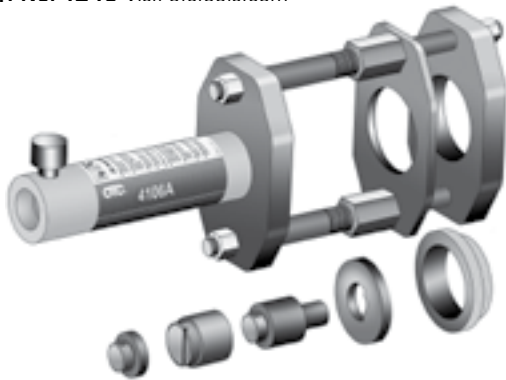

Hendrickson Part No. 66086-204

OTC Part No. 4247 Visit otctools.com

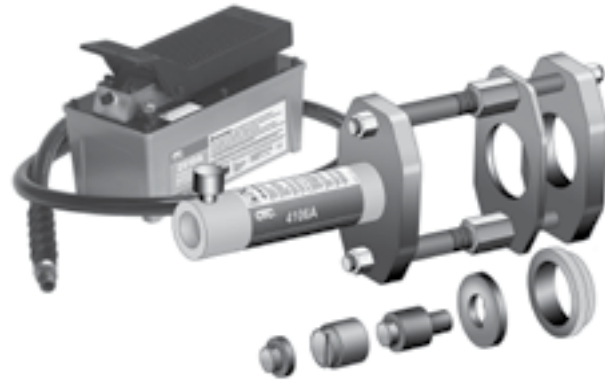

QUIK-ALIGN SOCKET TOOL

Hendrickson Part No. 66086-200

OTC Part No. 1767

Visit otctools.com



QUIK-ALIGN PIVOT BUSHING SERVICE TOOL

Hendrickson Part No. 66086-203L



TORQUE ROD BUSHING FUNNEL TOOLS

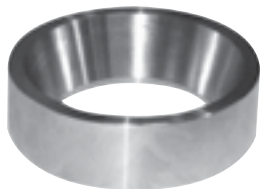

ULTRA ROD – Hendrickson Part No. 66086-001L

ULTRA ROD PLUS – Hendrickson Part No. 66086-000L

BAR PIN STYLE END BUSHING TOOLS**INSTALLATION TOOL****Hendrickson Part No. 66086-103****OTC Part No. 1757**
Visit otctools.com

Use with the equalizing beam removed from the truck, and in conjunction with OTC No. 51100 press plate and a 100-ton hydraulic shop press.

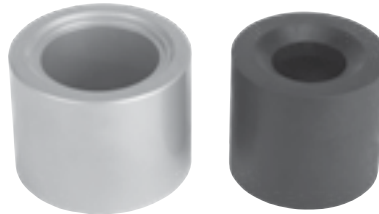
**REMOVAL TOOLS****Hendrickson Part No. 66086-104****OTC Part No. 206457** Visit otctools.com**Hendrickson Part No. 66086-105****OTC Part No. 302030** Visit otctools.com**ADAPTER STYLE END BUSHING TOOL SET • RUBBER CENTER BUSHING TOOLS****28K-52K lb. Capacity Bushings****Hendrickson Part No. 66086-102****OTC Part No. 1764** Visit otctools.com**40K lb. Capacity Bushings****Hendrickson Part No. 66086-100****OTC Part No. 1746** Visit otctools.com**65K-85K lb. Capacity Bushings****Hendrickson Part No. 66086-101****OTC Part No. 1763** Visit otctools.com

This is a general parts list to provide directional information. Components may vary by model. Questions in regards to parts, contact Hendrickson Truck Parts at 1.866.755.5968 (Toll-free U.S. and Canada), 630.910.2800 (Outside U.S. and Canada) or e-mail: truckparts@hendrickson-intl.com.

*Call Hendrickson at **1.866.755.5968** (toll-free) or **1.630.910.2800** for additional information.*



www.hendrickson-intl.com

SP-179 Rev G 03-21

© 2004 – 2021 Hendrickson USA, L.L.C. All Rights Reserved. All trademarks shown are owned by Hendrickson USA, L.L.C., or one of the affiliates, in one or more countries. Information contained in this literature was accurate at the time of publication. Product changes may have been made after the copyright date that are not reflected.

TRUCK COMMERCIAL VEHICLE SYSTEMS
800 South Frontage Road
Woodridge, IL 60517-4904 USA
1.866.755.5968 (Toll-free U.S. and Canada)
1.630.910.2800 (Outside U.S. and Canada)
Fax 1.630.910.2899

Printed in United States of America