



HAULMAX[®]

Heavy-Duty Lightweight
Rubber Suspension



- MAAXimize payload
- MAAXimize driver comfort
- MAAXimize durability

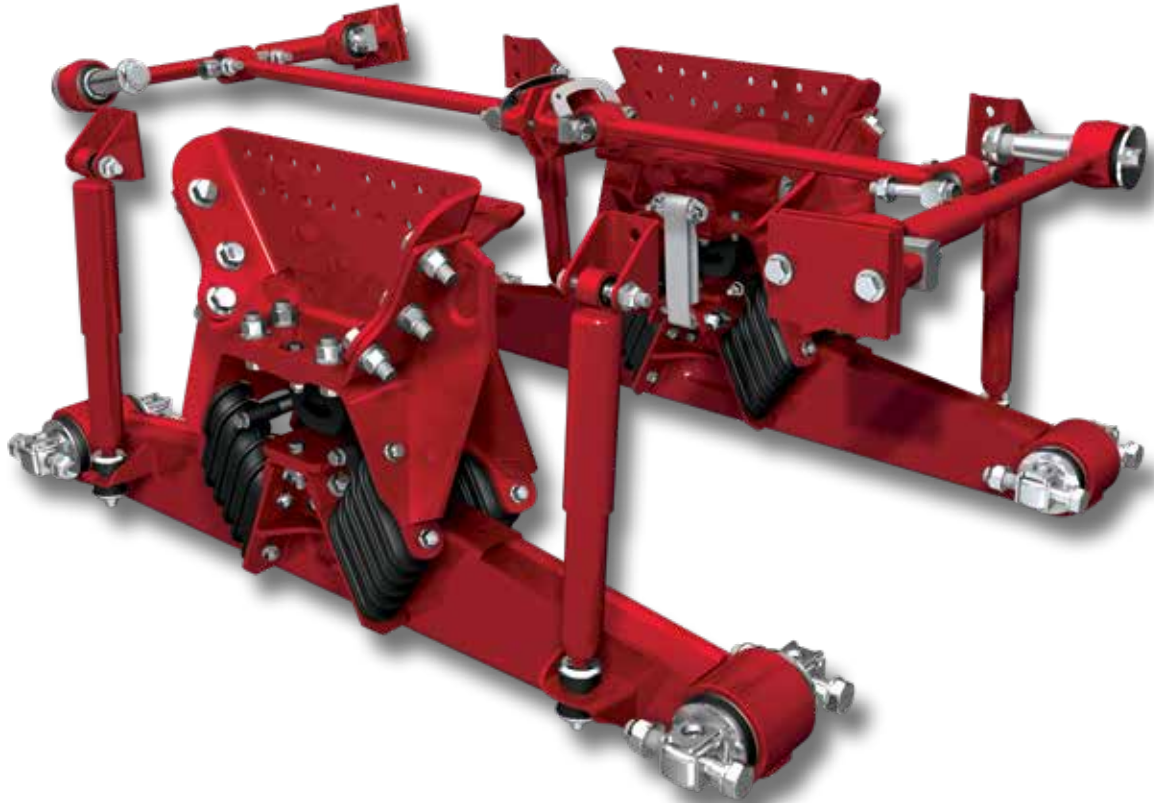

Take the next step in vocational suspension evolution — advance to HaulMAX[®]. Since its first tandem axle truck was built, the name “Hendrickson” has meant reliability, exceptional quality and durability. And through continuous innovation, Hendrickson is a world leader today with its comprehensive line of advanced, heavy-duty suspensions. Kenworth has teamed with Hendrickson to offer HaulMAX heavy-duty suspensions for greater payloads, driver comfort, reduced maintenance and off-highway mobility.



To learn more about HaulMAX,
call 855.743.3733 or visit
www.hendrickson-intl.com

 **HENDRICKSON**
The World Rides On Us[®]

Genuine Hendrickson Torque Rods

- Transverse torque rods ensure maximum lateral axle control and straight line suspension stability
- Longitudinal rods engineered to optimize resistance to wind up during acceleration and braking
- Improve cornering by controlling lateral forces

Saddle and Frame Bracket

- Lightweight modular design provides significant weight savings

Equalizing Beam

- Formed and robotically-welded beam provides a narrow profile for weight savings
- Distributes load equally between both axles for improved traction
- Lowers the center of gravity to increase stability
- Establishes a solid axle connection for improved handling
- Center bushing eliminated for reduced maintenance

Premium Rubber Springs

- Advanced rubber bolster springs and progressive load springs have a variable spring rate that helps optimize empty ride with loaded stability

Bar Pin End Connection

- Rugged axle connection extends bushing life and allows easy axle alignment and serviceability

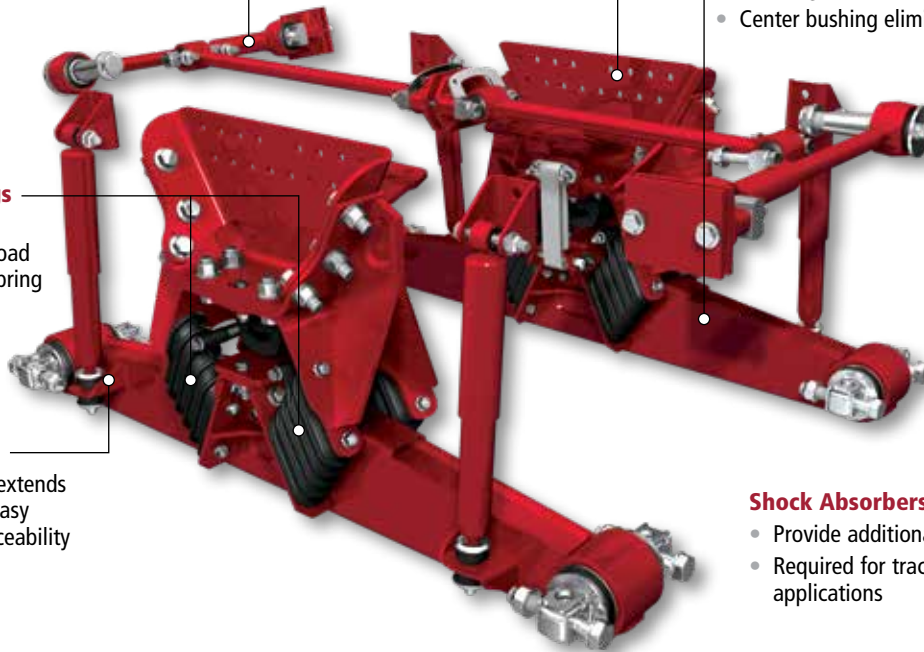

Shock Absorbers

- Provide additional driver comfort
- Required for tractor and logging applications



| MODEL | DATA CODE | AXLE SPACING | RIDE HEIGHT | SUSPENSION RATING | GVW APPROVAL ¹ | GCW APPROVAL | REQUIRED SHOCK ABSORBER APPLICATIONS ² |
|---------|-----------|--------------|-------------|-------------------|---------------------------|--------------|---|
| HMX 400 | 3732370 | 54 in. | Low | 40,000 lbs. | 73,000 lbs. | 160,000 lbs. | Tractors, Logging |
| HMX 400 | 3732972 | 54 in. | Standard | 40,000 lbs. | 73,000 lbs. | 160,000 lbs. | Tractors, Logging |
| HMX 460 | 3742970 | 54 in. | Low | 46,000 lbs. | 80,000 lbs. | 190,000 lbs. | Tractors, Logging |
| HMX 460 | 3742972 | 54 in. | Standard | 46,000 lbs. | 80,000 lbs. | 190,000 lbs. | Tractors, Logging |
| HMX 460 | 3742976 | 54 in. | High | 46,000 lbs. | 80,000 lbs. | 190,000 lbs. | Tractors, Logging |
| HMX 460 | 3742977 | 60 in. | High | 46,000 lbs. | 80,000 lbs. | 190,000 lbs. | Tractors, Logging |

¹ Contact Kenworth Application Engineering for applications that may exceed GVW approval ratings.

² Shock absorbers are standard equipment by Kenworth for optimum ride and traction. Shocks are required for tractor and logging applications and may be deleted for other applications (ref. sales code 3832018, subtract 30 lbs.). Contact Kenworth Application Engineering for further information.

Actual product performance may vary depending upon vehicle configuration, operation, service and other factors.

All applications must comply with applicable Hendrickson specifications and must be approved by the respective vehicle manufacturer with the vehicle in its original, as-built configuration. Contact Hendrickson for additional details regarding specifications, applications, capacities, and operation, service and maintenance instructions.

Call Hendrickson at **630.910.2800** or **855.RIDERED (743.3733)** for additional information.



www.hendrickson-intl.com

TRUCK COMMERCIAL VEHICLE SYSTEMS

800 South Frontage Road
Woodridge, IL 60517-4904 USA
855.RIDERED (743.3733)
630.910.2800 • Fax 630.910.2899



www.kenworth.com