

# TECHNICAL BULLETIN

## TRAILER SUSPENSION SYSTEMS HT250YS Y-BEAM SUSPENSION

**SUBJECT:** Recommended Inspection

**LIT NO:** T49001

**DATE:** November 2018

Hendrickson has become aware of a possible issue with certain HT250YS Y-beam suspensions. In a limited number of applications in the field, some HT250YS Y-beam suspensions have developed a crack in the yoke section of the suspension's trailing arm beam (Figure 1). In such circumstances, the initial crack will have negligible or no adverse effect on the performance of the axle or suspension. However, if this condition is allowed to progress over time, larger cracks could develop on the suspension beam yoke.

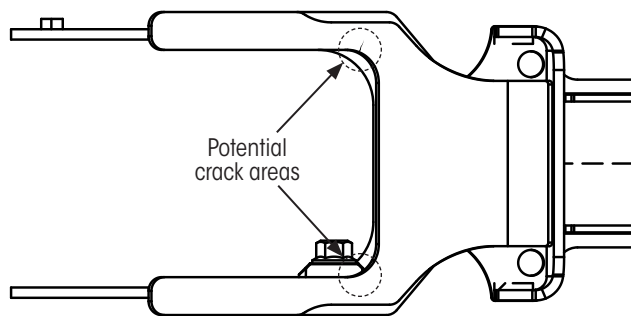

Figure 1: HT250YS Y-beam with crack forming (top view)

As a result, Hendrickson recommends all trailers equipped with HT250YS Y-beam suspensions be inspected for signs of cracking in the areas illustrated in Figure 1 (above) and Figure 2 on back page. This inspection can take place during the daily pre-trip inspection, during the trailer's periodic maintenance inspection inspections per Hendrickson literature number L578 *Preventive Maintenance Guide* or during unscheduled trailer maintenance.

If any cracks are observed, please contact Hendrickson Trailer Technical Services in the United States and Canada at 866-RIDEAIR (743-3247) or email [HTTS@Hendrickson-intl.com](mailto:HTTS@Hendrickson-intl.com) for information on how to proceed.

If a crack has progressed more than half way across the top plate (Figure 2 Crack B), the suspension should be immediately repaired, which will require a beam replacement. Contact Hendrickson as soon as possible.

### IMPORTANT SAFETY NOTICES

Hendrickson literature number **T12007** *Technical Procedure General Safety Precautions and Information*, available at [www.Hendrickson-intl.com/TrailerLit](http://www.Hendrickson-intl.com/TrailerLit), includes important preparation, precautionary and safety information pertaining to the procedures included in this document.

Improper maintenance, service or repair can cause damage to the vehicle and other property, personal injury, unsafe operating conditions and potentially void the manufacturer's warranty.

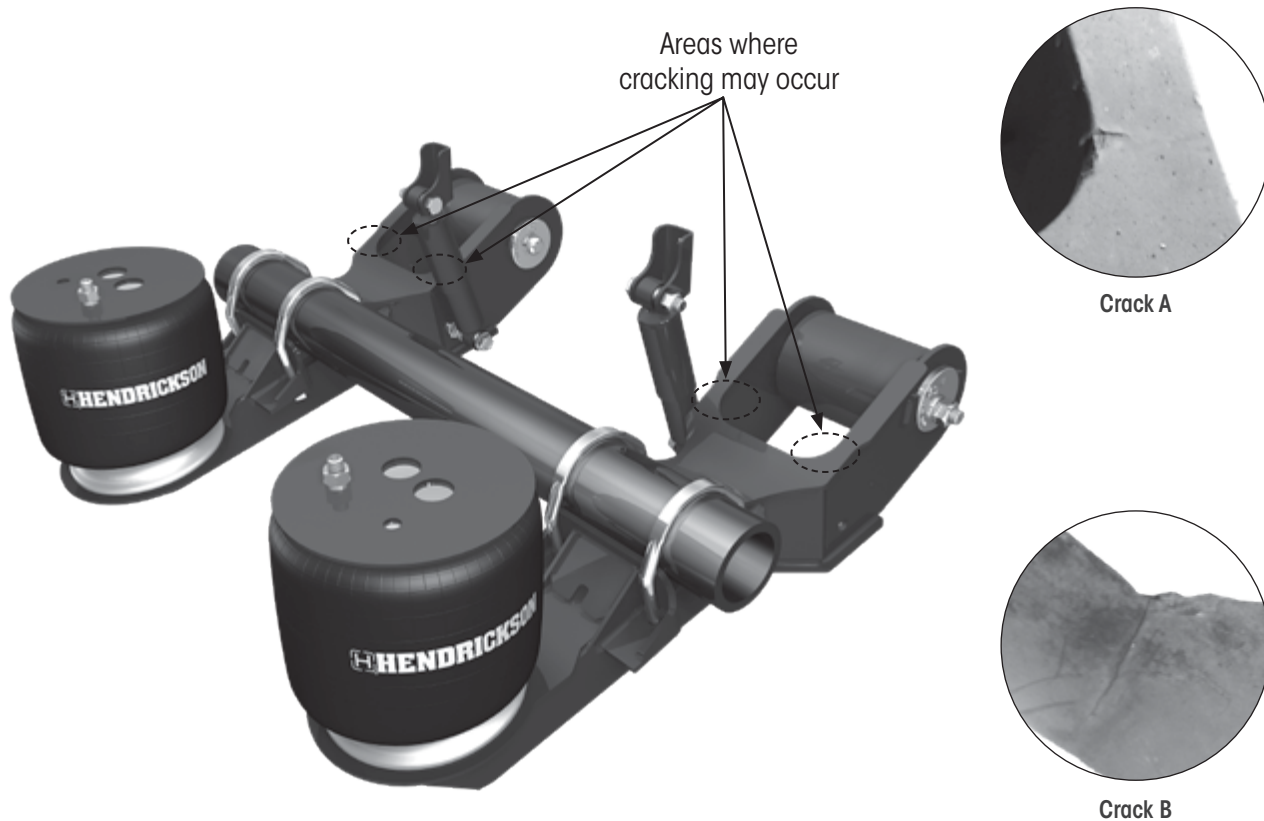

Figure 2: HT250YS Y-beam inspection areas

For assistance in the United States and Canada, call **Hendrickson Trailer Technical Services** at 866-RIDEAIR (743-3247) or email [HTTS@Hendrickson-intl.com](mailto:HTTS@Hendrickson-intl.com)

Call Hendrickson at **866.RIDEAIR (743.3247)** for additional information.



**TRAILER COMMERCIAL VEHICLE SYSTEMS**  
 2070 Industrial Place SE  
 Canton, OH 44707-2641 USA  
 866.RIDEAIR (743.3247)  
 330.489.0045 • Fax 800.696.4416

**Hendrickson Canada**  
 250 Chrysler Drive, Unit #3  
 Brampton, ON Canada L6S 6B6  
 800.668.5360  
 905.789.1030 • Fax 905.789.1033

**Hendrickson Mexicana**  
 Circuito El Marqués Sur #29  
 Parque Industrial El Marqués  
 Pob. El Colorado, Municipio El Marqués,  
 Querétaro, México C.P. 76246  
 +52 (442) 296.3600 • Fax +52 (442) 296.3601