

H PARTS LIST

Maxair • AL405 Rear Air Suspension for Mack Vehicles

LIT NO: SP-176

DATE: February 2011

REVISION: B

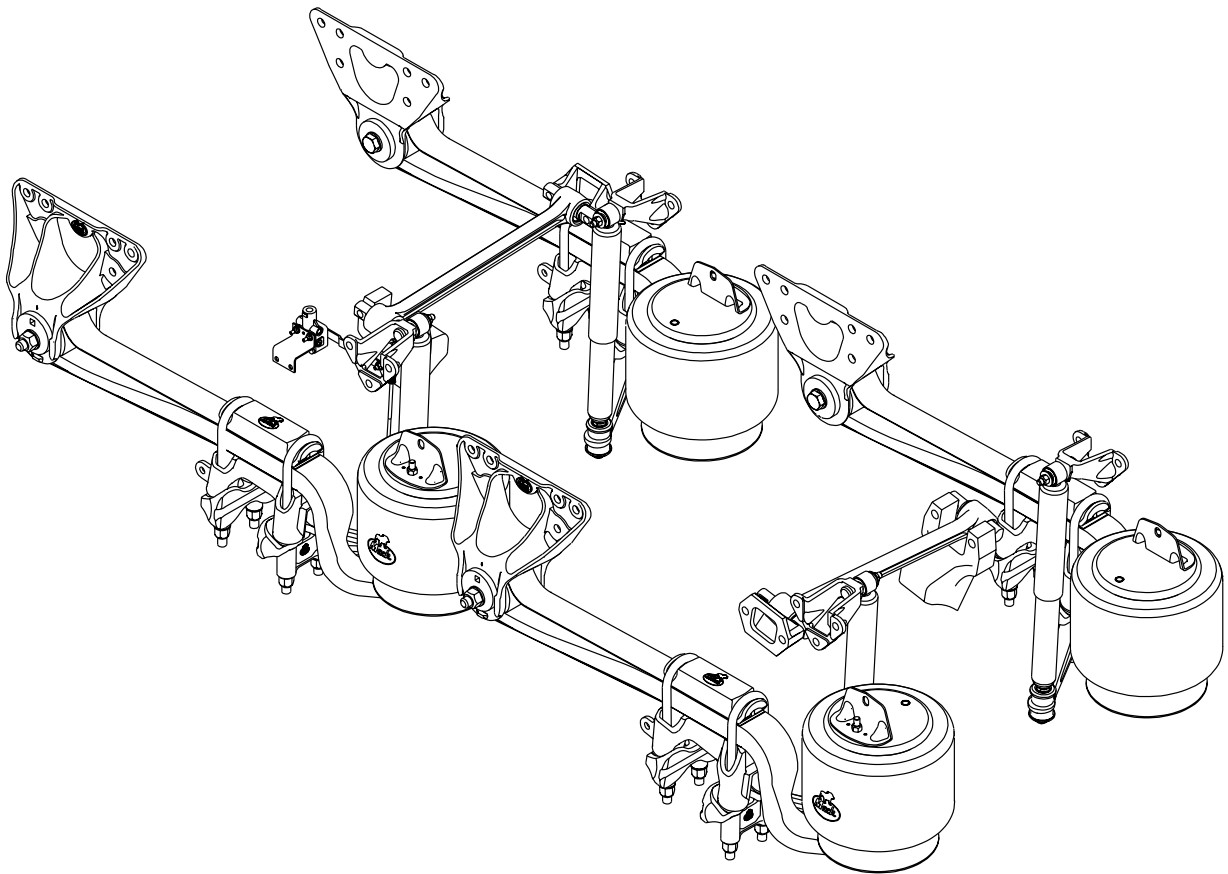

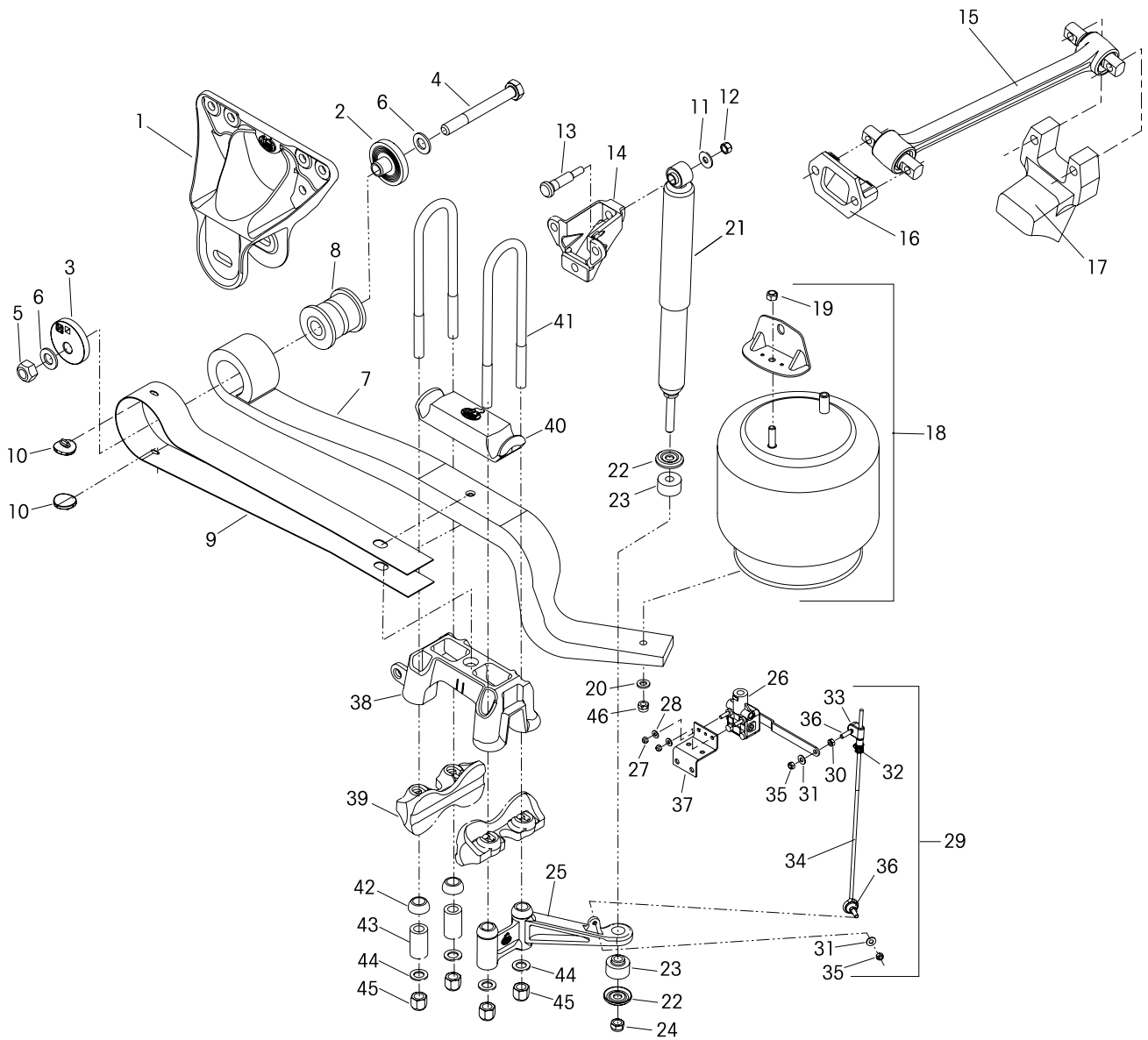



KEY NO.	PART NO.	DESCRIPTION	VEHICLE QTY.	KEY NO.	PART NO.	DESCRIPTION	VEHICLE QTY.
1	58772-001	Frame Hanger	2	23		***Rubber Bushings	
	58694-001	Ductile Iron-Std. <i>Replaced by 58772-001</i>		24		***5/8" UNC Locknut	
2	60497-000	QUIK-ALIGN® Concentric Base	6	25		Lower Shock Bracket	
	60661-000L	**QUIK-ALIGN Concentric Base Aluminum option	6		58701-001	LH	2
3	60496-000	QUIK-ALIGN Eccentric Base	2		58702-001	RH	2
	60662-000L	**QUIK-ALIGN Eccentric Base Aluminum option	2	26	59899-000	Height Control Valve Includes Key Nos. 27-28	1
4	58705-003	7/8"-9 UNC-2A x 7 1/2" Bolt	4	27		***1/4"-20 UNC Locknut	
	58705-005	**7/8"-9 UNC-2A x 8" Bolt Aluminum option	4	28		***1/4" Hardened Washer	
5	60266-000	7/8"-9 UNC-2B Locknut	4	29	58994-014	Height Control Valve Linkage Assembly Includes Key Nos. 30-36	1
6	22962-034	Hardened Flat Washer	8	30		***5/16"-18 UNC Nut	
7		Main Support Member, Includes Key Nos. 8-10		31		***5/16" Hardened Washer	
	58691-000	LH	2	32		***Valve Arm Clamp	
	58768-000	RH	2	33		***Valve Arm Joint	
8		***QUIK-ALIGN Pivot Bushing		34		***Extension Rod	
9		***Flexi-Wrap Strip		35		***5/16"-18 UNC Locknut	
10		***Rubber Isolator Pad		36		***5/16"-18 UNC Stud	
	58692-000	Shock Frame Hanger Assembly Includes Key Nos. 11-14	4	37	57975-000	Height Control Valve Bracket	1
11	22962-031	1/2" Hardened Washer	4	38		Spring Seat	4
12	49846-000	1/2"-13 UNC Locknut	4		59580-006	Front (4 1/2°)	
13	50368-000	1/2"-13 UNC 3.72" Bolt	4		64237-003	Rear (7 1/2°)	
14		***Shock Bracket Cast			59582-005	Rear (12°)	
15	58757-006	Transverse Rod Assembly	2		59582-008	Rear (13 1/2°)	
16	22186-000	Transverse Rod Frame Bracket	2	39		*Welded Axle Bracket	8
17		*Transverse Rod Axle Bracket	2	40	58775-002	Top Pad	4
18	58786-002	Air Spring Assembly Includes Key No. 19	4	41		*3/4" U-bolt	8
19		***Air Spring Locknut		42	49947-000	Spherical Washer	8
20	22962-014	Air Spring Flat Washer	4	43	58776-000	U-bolt Spacer Tube	8
21	57241-006L	Shock Absorber, Includes Key Nos. 22-24	4	44	22962-001	3/4" Flat Washer	16
22		***Retaining Washers		45		*3/4" Locknut	16
				46		*Air Spring Locknut	4

NOTE: Quantities specified are shown for tandem suspension.

* Not supplied by Hendrickson, used for reference only. Refer to OEM (vehicle manufacturer) for more information. Hendrickson is not responsible for components supplied by vehicle manufacturer. For assistance with maintenance and rebuild instructions on these components see vehicle manufacturer.

** When using the aluminum option, it is mandatory to use the aluminum bolt part no. 58705-005.

*** Item included in kit/assembly only, part not sold separately.

Hendrickson **MAXAIR** ride height gauge for vehicles built after March 19, 2001: Literature number **45745-164**
height gauge can be obtained on-line at www.hendrickson-intl.com/literature/lifform.asp

This is a general parts list to provide directional information. Components may vary by model. Questions in regards to parts, contact Hendrickson Truck Parts at 1.866.755.5968 (Toll-free U.S. and Canada), 630.910.2800 (Outside U.S. and Canada) or e-mail: truckparts@hendrickson-intl.com.

www.hendrickson-intl.com



Truck Commercial Vehicle Systems
800 South Frontage Road
Woodridge, IL 60517-4904 USA

1.866.755.5968 (Toll-free U.S. and Canada)
630.910.2800 (Outside U.S. and Canada)
Fax 630.910.2899