

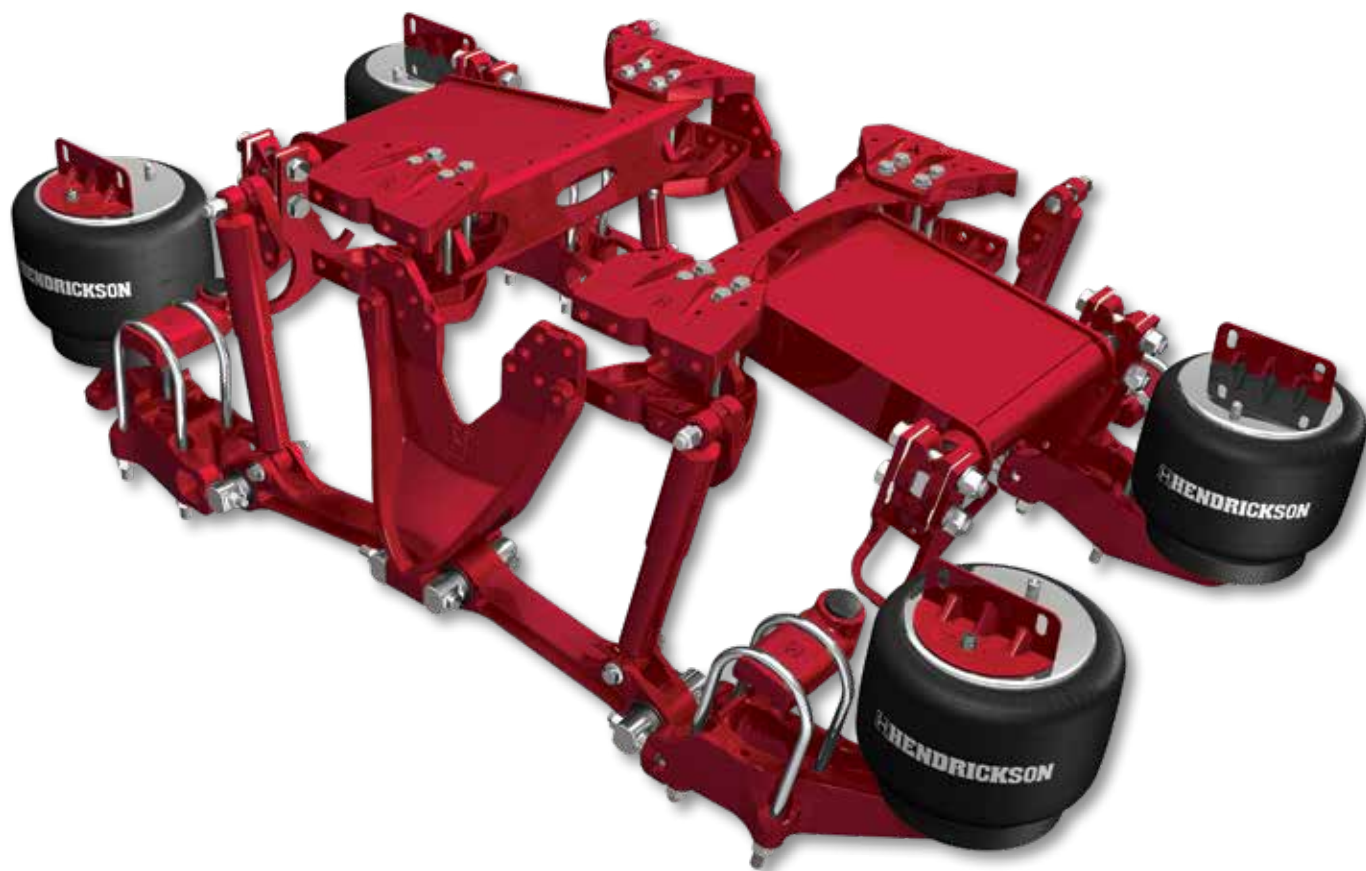

Lightweight Non-torque Reactive Rear Air Suspension

- Reduce weight by up to 305 lbs.*
- Increase durability
- Reduce maintenance



* Compared to typical trailing arm 40,000-pound capacity suspensions



To learn more about HTB LT,
call 855.743.3733 or visit
www.hendrickson-intl.com

 **HENDRICKSON**
The World Rides On Us®



HTB[®] LT

Lightweight, Non-torque Reactive Rear Air Suspension

Superior Ride

- Large volume, direct-acting air springs support 100 percent of the vertical load to improve ride

Improved Stability

- Unique, maintenance-free torque box system improves multi-axial stability and control

Non-Torque Reactive

- Approved for today's high horsepower engines with no torque restrictions
- Parallelogram design significantly controls suspension windup and corresponding frame rise
- Helps eliminate suspension induced driveline vibration

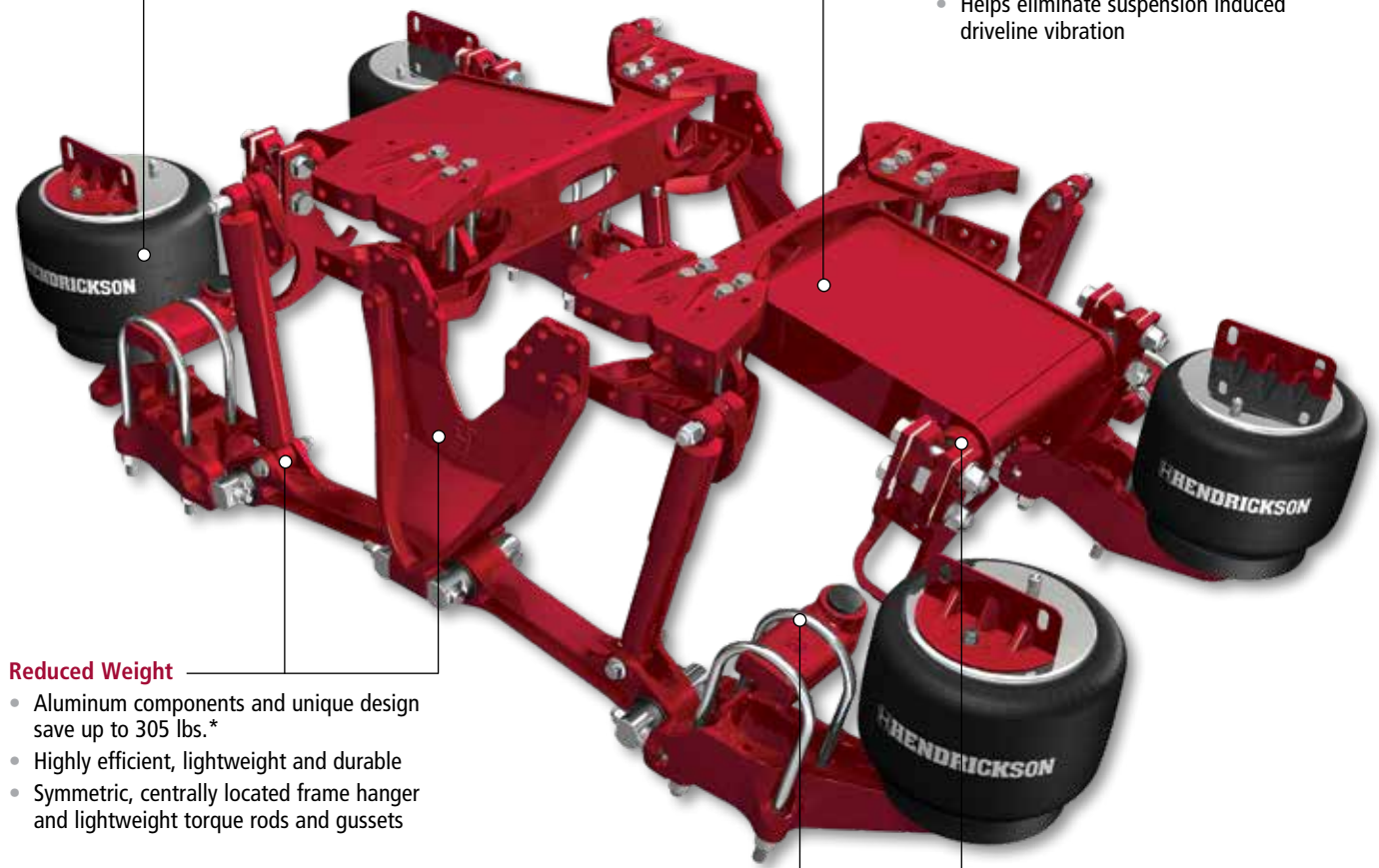

Reduced Weight

- Aluminum components and unique design save up to 305 lbs.*
- Highly efficient, lightweight and durable
- Symmetric, centrally located frame hanger and lightweight torque rods and gussets

Reduced Maintenance

- Premium rubber bushings require no lubrication, extend life and reduce noise and vibration
- Reduced re-torque requirements for U-bolts

* Compared to typical trailing arm 40,000-pound capacity suspensions

Reduced Weight

Lightweight Design

Weighing up to 305 pounds less than typical 40,000-pound capacity suspensions, HTB® LT provides lightweight drive-axle suspension efficiency.

Aluminum components, combined with a symmetric, centrally located frame hanger, reduce weight and part count to increase payload.

** Weight includes the suspension system and related components. Data is based upon internal testing and / or published specifications. Actual product specifications and performance may vary depending upon suspension and vehicle configuration, operation, service and other factors.*

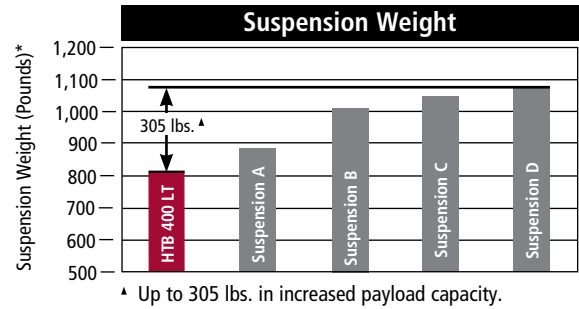

Reduced Maintenance

Zero Lubrication — All pivot points come equipped with premium rubber bushings requiring no lubrication. Torque box bushings are designed for long life.

Axle Alignment — The torque box, torque rods and clamp group joints provide consistent axle alignment and reduce the need for realignment.

Increased Durability

Non-Torque Reactive

HTB LT's parallelogram design significantly controls suspension windup and corresponding frame rise. Maintaining pinion angles throughout axle travel helps eliminate suspension induced driveline vibration and extends component life.

HTB® LT Parallelogram



- Axle torque controlled by torque box and torque rods
- Axle will not rotate, which maintains pinion angles and helps eliminate driveline vibration

Typical Trailing Arm

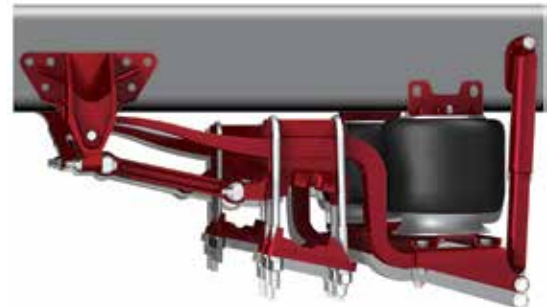

- Axle torque deflects main support member, resulting in partial axle rotation and pinion angle change — a possible contributing factor in driveline vibration and wear

Superior Ride

Optimized Ride — By carrying 100 percent of the vertical load on specially designed air springs, HTB LT delivers ride improvements over traditional trailing arm suspensions creating a smooth and comfortable ride.

HTB® LT Specifications

	HTB 200LT	HTB 400LT
Capacity	20,000 lbs.	40,000 lbs.
Installed Weight	431 lbs.	810 lbs.
Off-highway Rating	—	10%
Axle Configuration	Single	Tandem
GVW Approval	33,000 lbs.	55,000 lbs.
GCW Approval	60,000 lbs.	120,000 lbs.
Ride Heights	8- to 10-in.	8- to 10-in.
Engine Torque Restrictions	None	None
Axle Spacing	N/A	52-in.
Applications^{1, 3}		
General Freight (Van, Flatbed)	Yes	Yes
Refrigerated	Yes	Yes
Car Carrier	Yes	Yes
Bulk Hauler (Liquid, Dry)	Yes	Yes
Beverage	Yes	Yes
Dump ²	No	Yes

1. These are indicative of typical applications. Please contact your dealer or a Hendrickson service representative before using suspension on other applications.
2. Not for rock-body or mobile mix applications.
3. OEM approval required for applications with a lift axle.

This product is covered by at least one or more U.S. and/or foreign patents and/or pending U.S. and/or foreign patent applications. See Hendrickson for details.

Hendrickson Genuine Parts are the same quality components installed in Hendrickson original equipment suspensions — consisting of the same design, construction, performance and durability. There's only one way to maintain and protect your suspension's original performance. Ask for the name that is synonymous with the finest manufactured suspensions in the world.

Actual product performance may vary depending upon vehicle configuration, operation, service and other factors.

All applications must comply with applicable Hendrickson specifications and must be approved by the respective vehicle manufacturer with the vehicle in its original, as-built configuration. Contact Hendrickson for additional details regarding specifications, applications, capacities, and operation, service and maintenance instructions.

Call Hendrickson at **630.910.2800** or **855.RIDERED (743.3733)** for additional information.



www.hendrickson-intl.com

TRUCK COMMERCIAL VEHICLE SYSTEMS

800 South Frontage Road
Woodridge, IL 60517-4904 USA
855.RIDERED (743.3733)
630.910.2800 • Fax 630.910.2899

45745-238 Rev I 05-20

© 2005 – 2020 Hendrickson USA, L.L.C. All Rights Reserved. All trademarks shown are owned by Hendrickson USA, L.L.C., or one of its affiliates, in one or more countries. Information contained in this literature was accurate at the time of publication. Product changes may have been made after the copyright date that are not reflected.

Printed in United States of America