

# **WARRANTY** TRAILER SUSPENSION SYSTEMS

**SUBJECT:** Comprehensive Warranty Statement  
USA and Canada

**LIT NO:** L583

**DATE:** November 2009

**REVISION:** M

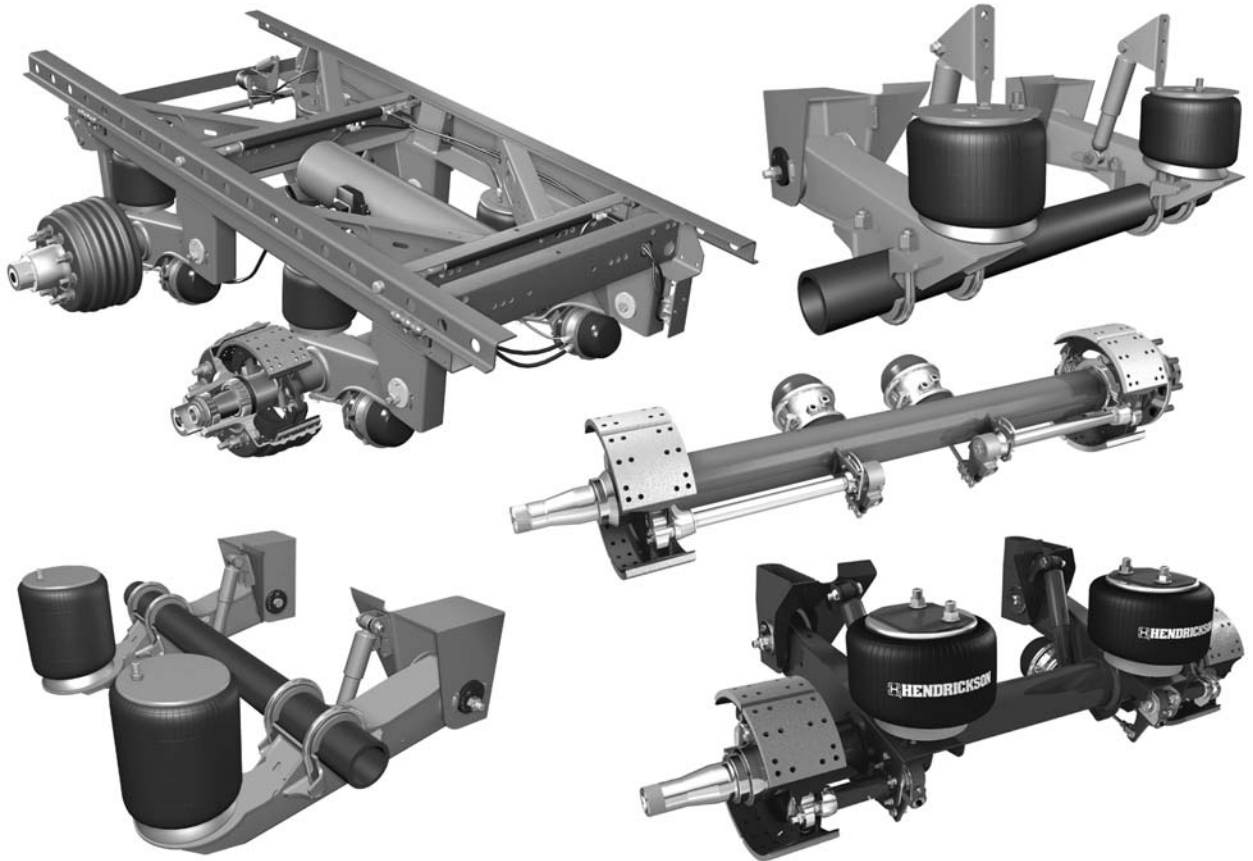

## TABLE OF CONTENTS

WARRANTY CONDITIONS .....	2
COVERAGE .....	2
WARRANTY CLAIM CONSIDERATIONS .....	3
Filing Warranty Claims .....	3
LABOR ALLOWANCES .....	4
COVERAGE TABLE .....	10
ADDITIONAL WARRANTY COVERAGE INFORMATION .....	18



**WARRANTY CONDITIONS**

Hendrickson Trailer Suspension Systems (Hendrickson) warrants that all trailer suspensions, listed on the following pages, shall be free of defects in material or workmanship. This warranty coverage only applies to those suspensions that have been properly assembled and installed by a trailer original equipment manufacturer (OEM), properly maintained (as described in all applicable Hendrickson publications) and used in the recommended application and within the rated capacities (as described in the Hendrickson *Application Guide*, publication L707). All non-recommended suspension applications must receive written approval from Hendrickson in order to be covered under this warranty. This warranty is subject to the conditions, exclusions and limitations listed below.

- Please contact the Hendrickson technical services department to receive warranty authorizations and/or to obtain warranty claim numbers (800-455-0043 in the United States or 800-668-5360 in Canada). Note that the terms and coverages in this warranty document apply only to the United States and Canada. If you need warranty information for Mexico, contact Hendrickson Mexicana at +52 (81) 8156-1300.
- Prior to the warranty repair or replacement of suspension systems or parts (by a dealer or other service provider authorized by the OEM of the subject trailer), the warranty claim must first be approved by the Hendrickson technical services department. Trailer dealers should inspect all suspensions involved in a warranty claim and then contact Hendrickson for assistance.
- Parts to be returned under a warranty claim must be accompanied by an RGO (returned goods order), RGA (returned goods authorization) or the warranty claim number issued by the Hendrickson technical services department.
- Parts returned under a warranty claim number must be sent prepaid. Hendrickson will reimburse the customer for the freight charges if the returned parts are confirmed to be defective or non-functioning.
- Only genuine Hendrickson parts, or parts sold through Hendrickson, may be used to repair Hendrickson suspension systems. Our warranty also applies only to genuine Hendrickson parts.

- Refer to the labor allowances on pages four through seven for a listing of typical repairs. Contact the Hendrickson technical services department to discuss allowances for anything not listed.
- Hendrickson has the sole discretion and authority to approve or disapprove a warranty claim, authorize the repair or replacement of non-functioning systems and authorize the repair or replacement of parts.
- Replacement parts provided under warranty are not warranted, they simply inherit the remainder of the suspension warranty. Goodwill or giveaway (sales policy) parts provided at no charge have no warranty.

When contacting the technical services department to receive warranty authorization, costs and procedures will be determined (see labor allowance chart for a listing of typical repairs). Hendrickson will pay a specified labor allowance, determined by the Hendrickson technical services department for the authorized repair or replacement of any defective component. Hendrickson is not responsible for any additional costs that may be incurred when replacement parts or materials are not acquired through Hendrickson.

**COVERAGE**

The Hendrickson suspension warranty coverage begins when the vehicle is put into service and ends when the time period specified in the warranty-coverage table (pages 10 through 17) is reached.

The warranty shall not apply to or include any repair or replacement as a result of the following conditions:

- Bending of the Trailer Axle, INTRAAX axle, or VANTRAAX axle
- Accident, fire or other casualty
- Misuse or negligence including, but not limited to, overloading
- Lack of reasonable and proper maintenance
- Repairs improperly performed or replacements improperly installed
- Use of component parts, replacement or otherwise, that are not manufactured or distributed by Hendrickson
- Modifications not recommended or approved by Hendrickson (in writing)
- Uses other than those intended by Hendrickson and the trailer OEM



- Normal wear and deterioration occasioned by the use of the suspension system
- Any damage or failure caused by or otherwise attributed to any vehicle or trailer components, systems or equipment that are not manufactured or distributed by Hendrickson

The liability of Hendrickson under this warranty is limited solely to the repair or replacement of defective material or workmanship by an authorized party. Hendrickson shall not be liable for repairs performed by any unauthorized parties. This warranty does not include any expense of or related to transportation of the parts to or from the place where the repair is to be performed or compensation for inconvenience or loss of use while the suspension system is being repaired. Hendrickson shall not be liable for any expense, loss or damage (direct, incidental, consequential or exemplary — including, but not limited to, towing expenses, downtime expenses, cargo damage, incidental charges or any other losses arising in connection with the sale, use or inability to use the suspension system) resulting from the warranty-covered part found to be defective.

No expressed warranty is given by Hendrickson with respect to its suspension systems and products except as specifically set forth herein. Any warranty implied by law, including any warranty of merchantability or fitness for a particular purpose, is limited to the expressed warranty term provided in the warranty-coverage table (pages 10 through 17).

## WARRANTY CLAIM CONSIDERATIONS

- **SYSTEM PROBLEMS OR PARTS FAILURES THAT RESULT FROM IMPROPER INSTALLATION ARE THE RESPONSIBILITY OF THE INSTALLER OF THE SUSPENSION.** These are not warranted by Hendrickson.
- **THE HENDRICKSON TECHNICAL SERVICES DEPARTMENT MUST AUTHORIZE REPAIRS PRIOR TO THEM BEING PERFORMED.** When authorizing repairs or services, the warranty administrator will determine the costs and procedures (see the labor allowances on pages four through eight for a listing of typical repairs). Failure to receive Hendrickson authorization may result in partial or complete loss of warranty coverage.
- **DO NOT DESTROY THE PARTS BEING CONSIDERED FOR WARRANTY!** All parts in question must be returned to Hendrickson for evaluation. Failure to

return such parts may result in partial or complete loss of warranty coverage.

- **“SHOP SUPPLY” REIMBURSEMENT MAXIMUM.** The maximum amount to be considered for miscellaneous supply, shop supply, or job supply reimbursement is 4 percent of invoiced labor charges, up to a maximum of \$20.

## FILING WARRANTY CLAIMS

1. Review warranty coverage for the component(s).

If the component complies with the stated time period for warranty coverage, continue with step two.

2. Locate, record and provide to Hendrickson the following information:
  - Hendrickson suspension model number
  - Hendrickson model serial number
  - Type of vehicle, name of vehicle manufacturer and VIN (vehicle identification number)
  - Approximate number of suspension miles
  - Model’s in-service date
  - Description of the system problem and/or the part number of the non-functioning part
  - Special application approval documentation (if applicable)

3. Contact the proper authority:

- A. IF YOU ARE AN END USER (OWNER) OR DEALER:** Report the problem to the trailer manufacturer or the suspension installer.

If the problem is not related to installation, the manufacturer or installer will contact Hendrickson to file the warranty claim.

- B. IF YOU ARE A TRAILER MANUFACTURER:** Contact the Hendrickson Trailer technical services department at 800-455-0043 (in the United States) or at 800-668-5360 (in Canada) and provide the information recorded in step two. If operating in Mexico, please refer to Hendrickson publication L826SP, *Póliza de Garantía - México* for warranty information.

The technical services department will issue an RGO, RGA or warranty claim number for each submitted claim. All parts to be returned to Hendrickson or its vendors must be



labeled with this claim number and shipped within 60 days for timely processing of the warranty claim.

4. Submit a work order job description with your RGO, RGA or warranty claim number describing what is to be repaired or replaced (refer to the standard repair times listed on pages four through eight). This work order job description should be as itemized and detailed as possible for prompt processing and maximum consideration.

**LABOR ALLOWANCES**

The standard repair times listed here include but are not limited to the parts in the itemized description. It may be necessary to remove and install additional parts not included in the basic descriptions in order to complete the warranty repair.

Detailed repair descriptions must be included with the submitted warranty claim.

If a warranty claim is submitted with a repair time in excess of the following standard repair times, then a detailed description explaining the reason for the excess is required.

The following labor allowances have been based upon work conducted by various repair facilities and include technician set-up time, diagnostic time and consideration of applicable supervisory/administration requirements.

Refer to the Suspension Type Definitions on page nine for an explanation of the abbreviations (i.e., HKA, AAZ, etc.) used in the following labor allowances.

<b>COMPONENT DESCRIPTION</b>	<b>TIME(HOURS)</b>
TRI-FUNCTIONAL® Bushings	4.0 (per axle)
Includes:	
• Removal and replacement of:	
- TRI-FUNCTIONAL Bushings*	
- Bushing tube spacers	
- Pivot connection hardware*	
• Axle alignment*	

<b>COMPONENT DESCRIPTION</b>	<b>TIME(HOURS)</b>
Bushing tube spacers	1.5 (per axle)
Includes:	
• Removal and replacement of:	
- Bushing tube spacers	
- Pivot connection hardware*	
• Axle alignment*	
Air spring/piston	
Each air spring (up to three)	1.0
Each additional air spring	.5
Center lift air spring	.5
Shock absorber	.5
Shock bracket (upper)	
Weld-on	1.5
Bolt-on	1.0
Shock bracket (lower)	
AAL, AAEDT and AAEDL rear-mount only	1.0
Frame bracket (welded)	4.0
Includes:	
• Removal and replacement of:	
- Pivot connection hardware*	
• Axle alignment*	
Axle alignment (dual axles with QUIK-ALIGN®)	1.0
• Each additional axle	.5
Includes:	
• Removal and replacement of:	
- QUIK-ALIGN pivot connection hardware*	
Axle alignment (dual axles with welded collars)	1.5
• Each additional axle	.8
Includes:	
• Removal and replacement of:	
- Pivot connection hardware*	
Frame bracket (bolt-on)	3.0
Includes:	
• Removal and replacement of:	
- Pivot connection hardware*	
• Axle alignment*	
Beam and axle seat assembly for HT and T suspensions	4.0
Air reservoir	1.0

\* Installed/performed following the approved Hendrickson procedure.



# COMPREHENSIVE WARRANTY STATEMENT

COMPONENT DESCRIPTION	TIME(HOURS)	COMPONENT DESCRIPTION	TIME(HOURS)
Valves		Brake shoes with linings (does not require hub removal)	2.5 (per axle)
Quick release valve	1.0	Includes:	
Height control valve	1.0	• Removal and replacement of:	
Includes:		- Brake shoe with lining*	
• Removal and installation of height control valve linkage		• Removal and installation of:	
• Ride height adjustment		- Tire/wheel assembly	
Height control valve linkage	.5	- Hub and drum	
Solenoid valve	1.0	• Brake adjustment	
Air pilot valve	1.0	Brake drum (outboard)	.5
Brake protection valve	1.0	Includes:	
Flipper valve	1.0	• Removal and installation of:	
Dial-a-ride	1.0	- Tire/wheel assembly	
Hand control valve	1.0	• Brake adjustment	
Manual exhaust valve	1.0	Brake dustshield/clamp	
Pressure protection valve	1.0	Each (up to two)	.5
Brake chamber	.8	Each additional (up to four)	1.0
Brake hose (relay valve to brake chamber)	.5	Brake camshaft — INTRAAX® models "A" and "B" (Requires hub removal)	1.6
ABS wheel sensor (one)	1.0	Includes:	
Includes:		• Removal and installation of:	
• Removal and installation of:		- Tire/wheel assembly	
- Tire/wheel assembly		- Hub and drum	
- Brake drum		- Slack adjuster	
Adjust ABS wheel sensors (up to four)	.5	• Brake adjustment	
Includes:		Brake camshaft only — INTRAAX model "C" and Cam Tube System models (does not require hub removal)	1.2
• Troubleshooting		Includes:	
ABS relay valve	1.0	• Removal and installation of:	
Includes:		- Tire/wheel assembly	
• Troubleshooting		- Brake drum	
ABS modulator valve	1.1	- Slack adjuster	
Includes:		• Brake adjustment	
• Troubleshooting		Brake camshaft and cam tube assembly — INTRAAX model "C" and Cam Tube System models (does not require hub removal)	1.4
ABS electronic control unit (ECU)	1.1	Includes:	
Includes:		• Removal and installation of:	
• Troubleshooting		- Tire/wheel assembly	
Slack adjuster	.7	- Brake drum	
Includes:		- Slack adjuster	
• Troubleshooting		• Brake adjustment	

\* Installed/performed following the approved Hendrickson procedure.





# COMPREHENSIVE WARRANTY STATEMENT

COMPONENT DESCRIPTION	TIME(HOURS)	COMPONENT DESCRIPTION	TIME(HOURS)
<ul style="list-style-type: none"> <li>- One air reservoir and mounting brackets</li> <li>- Air valves</li> <li>- Suspensions</li> <li>- Brake lines</li> <li>- Brake valves</li> <li>- ABS valves and sensor wiring</li> <li>- Height control valve</li> <li>- QUIK-DRAW® slider pin-pull mechanism</li> </ul>		Air spring top shim plate to bottom of K-brace Includes: <ul style="list-style-type: none"> <li>• Removal and installation of:               <ul style="list-style-type: none"> <li>- Air spring</li> </ul> </li> </ul>	1.3
Does not include:		QUIK-DRAW control valve	.5
<ul style="list-style-type: none"> <li>• Additional air reservoirs and mounting brackets</li> <li>• SURELOK® trailer ride height locking system</li> <li>• Binkley Quick Release pin-pull mechanism</li> <li>• Tire inflation systems</li> </ul>		QUIK-DRAW control valve knob	.2
Additional labor time is required for these items.		QUIK-DRAW linear actuator (HK/HKA models):	
K-brace reinforcement plate installation	3.0	Front	.5
VANTRAAX® HKAT 50K (HKA250) only;		Rear	.8
quantity of four per slider		QUIK-DRAW air chamber actuator (AAZ models)	.8
Slider box replacement (AAZ models)		QUIK-DRAW® retrofit kit (HK/HKA models)	2.0
Single	8.0	Includes:	
Tandem	12.0	• Removal of original pin-pull mechanism	
Includes:		SURELOK® return spring	.2
• Removal and replacement of:		SURELOK actuator	.5
- Pivot connection hardware*		SURELOK restraint bolt	.5
• Axle alignment*		Includes	
• Removal and installation of:		• Adjustment and system check	
- Tire/wheel assembly		SURELOK ride height lock assembly	1.0
- Air springs		Includes:	
- Shocks and shock mounting hardware		• Adjustment and system check	
- Air lines		SURELOK retrofit kit (HK/HKA models)	
- One air reservoir and mounting brackets		Bolt-on beam extensions	2.0
- Air valves		Weld-on beam extensions	3.0
- Suspensions		Pivot connection hardware	1.0 (per axle)
- Brake lines		Includes:	
- Brake valves		• Removal and replacement of:	
- ABS valves and sensor wiring		- Existing pivot connection hardware*	
- Height control valve		• Axle alignment*	
- QUIK-DRAW slider pin-pull mechanism		TIREMAAX® kit complete installation	
Does not include:			
• Additional air reservoirs and mounting brackets			
• Tire inflation systems			
Additional labor time is required for these items.			
Slider pin (up to four)	1.5		
Slider pin springs (all four)	1.5		
Slider box wear pad, upper (pair)	3.0		
Slider box weld repair			
Cross member or K-brace to side rail;	1.0		
up to four welds			

\* Installed/performed following the approved Hendrickson procedure.

# COMPREHENSIVE WARRANTY STATEMENT



COMPONENT DESCRIPTION	TIME(HOURS)	COMPONENT DESCRIPTION	TIME(HOURS)
(EC <sup>1</sup> and CP <sup>2</sup> models)		Tandem	
Tandem		• Prepped INTRAAX® axle	6.0
• Prepped INTRAAX axle	6.0	• Non-prepped INTRAAX axle	12.0
• Non-prepped INTRAAX axle	12.0	Each additional axle	
Each additional axle		• Prepped INTRAAX axle	1.0
• Prepped INTRAAX axle	1.0	• Non-prepped INTRAAX axle	2.0
• Non-prepped INTRAAX axle	2.0		
TIREMAAX tire hoses (EC and CP models)		HTIS tire hoses	
First wheel end (one or two hoses)	.3	First pair (one or two hoses)	.3
Each additional wheel end (per trailer)	.2	Each additional wheel end (per trailer)	
Includes:		Includes:	
• Removal and installation of:		• Removal and installation of:	
– Tee fitting guard (if present)		– Tee fitting guard (if present)	.2
TIREMAAX tee fitting (EC and CP models)		HTIS tee fitting	
Up to four (per trailer)	.5	Up to four (per trailer)	.5
Each additional (same trailer)	.2	Each additional (same trailer)	.2
Includes:		Includes:	
• Removal and installation of:		• Removal and installation of:	
– Tee fitting guard (if present)		– Tee fitting guard (if present)	
TIREMAAX rotary union (EC and CP models)		HTIS rotary union	
Each	.5	Each	.5
Includes:		Includes:	
• Removal and installation of:		• Removal and installation of:	
– Hubcap		– Hubcap	
– Internal axle hose attachment		– Internal axle hose attachment	
• Removal and replacement of:		• Removal and replacement of:	
– Hubcap gasket		– Hubcap gasket	
– Spindle end plug		– Spindle end plug	
– Oetiker hose clamp		– Oetiker hose clamp	
TIREMAAX controller assembly (EC and CP models)	1.0	HTIS controller assembly	1.0
TIREMAAX EC target pressure programming		HTIS system setup program	
using the hand-held programming device		System learn (manual) method	.8
(does not require controller		Service tool method	.5
assembly removal)	.2	Tire inflation system wiring harness	
HTIS kit complete installation		(HTIS and TIREMAAX EC and CP models)	
		Premium, ABS-ready harness	1.0
		Standard, 3-wire adapter plug	.5

<sup>1</sup> EC - Electronic Controller

<sup>2</sup> CP - Constant Pressure



### SUSPENSION TYPE DEFINITIONS

The suspension type abbreviations used in the coverage table on pages 10 through 17 are defined as follows:

#### Slider Suspension Systems

**AAZ** - Any INTRAAX® suspension on a Z-rail platform slider. In cases where warranty coverage or components differ for a certain AAZ model, the specific model will be noted by one of the following descriptions: **AAZNT, AAZL**.

**HKA** - All VANTRAAX® slider systems (INTRAAX suspensions on a K-2® slider box). In cases where warranty coverage or components differ for a certain VANTRAAX model, the specific model will be noted by one of the following descriptions: **HKANT, HKAT, HKAL, HKARL**.

**HK** - HT suspensions on K-2 slider box

**HS** - HT suspensions on HS slider box

**Axle, Trailer** - Non-integrated trailer axle only, includes brackets

**HCA** - Hendrickson Chassis Axle

**RS** - Sliding trailing arm suspension, formerly manufactured by the Dana Corporation

**SL** - All QUAANTUM slider systems (INTRAAX suspensions with specific premium components). The part number on a QUAANTUM suspension ID tag will begin with "QUTM..." to show identity.

**ZR** - Any QUAANTUM suspension on a Z-rail platform slider.

#### Primary Fixed and Lifiable Suspensions

**AA** - All INTRAAX primary suspensions. In cases where warranty coverage or components differ for a certain INTRAAX model, the specific model will be noted by one of the following descriptions: **AANT, AAT, AAEDT, AANLS, AANL, AAL, AAEDL**.

**HT** - HT Series primary suspensions

**T** - T Series primary suspensions

**RF** - Fixed trailing arm suspension, formerly manufactured by the Dana Corporation

**B2AHT** - Non-integrated trailer axle to HT suspension union, assembled by Hendrickson

**FX** - All QUAANTUM primary suspensions. In cases where warranty coverage or components differ for a certain QUAANTUM model, the specific model will be noted by one of the following descriptions: **NT, T, L, NLS, NL**.

### COVERAGE TABLE

The coverage periods in the following table apply when the suspension has been properly assembled and installed by a trailer original equipment manufacturer (OEM), properly maintained (as described in all applicable Hendrickson publications) and used in the recommended application and within the rated capacities (as described in the Hendrickson *Application Guide*, publication L707). Coverage may differ on some items used in applications for which special written approval from Hendrickson has been granted. For more warranty coverage information, contact the Hendrickson technical services department at 800-455-0043 in the United States or at 800-668-5360 in Canada. If you need warranty information for Mexico, contact Hendrickson Mexicana at +52 (81) 8153-1300 or refer to Hendrickson publication L826SP, *Póliza de Garantía - México* for warranty information.

### MILEAGE TERMS

The parts and labor warranty coverage periods in the following table are based on a typical annual average usage of 100,000 miles. However, some high-mileage applications can easily reach 250,000 miles per year and above. Hendrickson, at its sole discretion, may adjust warranty coverage on a case-by-case basis for applications exceeding 100,000 miles per year during the respective warranty period.



COVERAGE TABLE (CONTINUED)

ITEM DESCRIPTION	SUSPENSION TYPE <sup>1</sup>	PARTS	LABOR	COMMENTS (RESTRICTIONS, ETC.)
<b>SUSPENSION SYSTEM</b>				
QUANTUM	FX, SL, ZR	5 years	5 years	If equipped with HUS wheel ends, an additional 2 years parts and labor applies to the wheel ends only
<b>SUSPENSION AND AXLE<sup>7</sup> COMPONENTS</b>				
Axle, Trailer (non-integrated, includes brackets)	Axle only	5 years	1 year	Includes intermodal chassis. Warranty void when brake camshaft rotation is opposite of wheel rotation.
Integrated Axle / Trailing Arm Assembly <sup>2</sup>	AA, AAZ, HKA RS, RF	5 years	1 year	<b>If used in the raw wood industry<sup>3</sup>:</b> Parts - 3 years Labor - 1 year
Integrated Trailing Arm-to-Axle Connection <sup>6</sup>	AA, AAZ, HKA RS, RF	10 years	5 years	<b>If used in the raw wood industry<sup>3</sup>:</b> Parts - 3 years Labor - 1 year
Frame Brackets (Hangers)	All	5 years	1 year	<b>If used in the raw wood industry<sup>3</sup>:</b> Parts - 3 years Labor - 1 year
Trailing Arms (Beams)	T HT	5 years	1 year	<b>If used in the raw wood industry<sup>3</sup>:</b> Parts - 3 years Labor - 1 year
Non-Integrated, Trailing-Arm-to-Axle Connection	B2AHT	1 year	1 year	
<b>TRI-FUNCTIONAL<sup>®</sup> BUSHINGS AND BUSHING TUBE SPACERS* (NOT AVAILABLE — SERVICED WITH TF II)</b>				
TRI-FUNCTIONAL <sup>®</sup> Bushings and Bushing Tube Spacers*	T, HT, HK, HS	5 years	1 year	<b>If used in the raw wood industry<sup>3</sup>:</b> Parts - 3 years Labor - 1 year
<b>TRI-FUNCTIONAL II BUSHINGS AND BUSHING TUBE SPACERS*</b>				
49" Closed- Spaced Van Applications <sup>4</sup>	AAT, AAL, HT, HKAT, HKARL, HK, HS	7 years	5 years	
Vocational, Wide-Spread Van and/or Liffable Axle <sup>5</sup>	HT, HKAT, AAT, AAL, AAZL, AAEDT, AAEDL	5 years	3 years	<b>If used in the raw wood industry<sup>3</sup>:</b> Parts - 3 years Labor - 1 year

\*Effective with suspensions built and delivered after 2/1/01.

Continued on page 11

<sup>1</sup>Refer to page nine for suspension type definitions.

<sup>2</sup>Axles that are drilled for tire inflation system (Hendrickson or otherwise) that do not follow Hendrickson's recommended drilling procedures (as described in Hendrickson publications L786, *Hendrickson Tire Inflation System - Installation, Service and Troubleshooting Procedures* or L818, *TIREMAAX<sup>®</sup> Tire Inflation System - Installation, Service and Troubleshooting Procedures*) could void the axle warranty. Unrecommended drilling could cause damage to the axle or other suspension components. Refer to pages 15 through 17 for additional information.

<sup>3</sup>Hendrickson defines the raw wood industry as any forestry application that involves or includes, but is not limited to, logging or chip hauling. INTRAAX AAEDT 30K and AAEDL 30K models are recommended for these applications, and are covered by the standard INTRAAX warranty. AAT 30K and AAL 30K may also be used when written application approval is received from Hendrickson engineering, in which case the standard INTRAAX warranty shall apply. Other INTRAAX and HT models, when used in accordance with Hendrickson publication L707, *Application Guide*, will be covered under the reduced warranty terms noted here. Refer to page 18 for further raw wood warranty information.

<sup>4</sup>For highway use only in single-axle or closed-spaced (for example, 49 inches) tandem applications on van- and reefer-type trailers.

<sup>5</sup>For all vocational trailers, wide-spread and tridem sliders, specially or spread-axle vans and reefers, and liftable axle suspensions.

<sup>6</sup>For RS and RF trailing arm-to-axle connections, coverage is 10 years parts, 5 years labor (highway use only) and 3 years parts, 1 year labor (vocational).

<sup>7</sup>Cambering an axle in the field voids the axle warranty.



COVERAGE TABLE (CONTINUED)

ITEM DESCRIPTION	SUSPENSION TYPE <sup>1</sup>	PARTS	LABOR	COMMENTS (RESTRICTIONS, ETC.)
<b>TRI-FUNCTIONAL III BUSHINGS AND BUSHING TUBE SPACERS*</b>				
49" Closed-Space Van Applications <sup>4</sup>	HKANT	7 years	5 years	
Vocational, Wide-Spread Van and / or Liffable Axle <sup>5</sup>	AANT, AANL, HKANT, AAZNT, AANLS	5 years	3 years	
<b>PIVOT BUSHINGS</b>				
49" Closed-Space Van Applications <sup>4</sup>	RS, RF	7 years	5 years	
Vocational, Wide-Spread Van and / or Liffable Axle <sup>5</sup>	RF	5 years	3 years	If used in the raw wood industry <sup>3</sup> : Parts - 3 years, Labor - 1 year
<b>SUSPENSION COMPONENTS</b>				
QUIK-ALIGN® Pivot Assembly	All	1 year	1 year	For non pre-aligned systems, proper trailer OEM installation is required <sup>2</sup>
Air Springs	All	2 years	1 year	
Air and Electronic Controls	All	1 year	1 year	
Shock Absorbers	All	2 years	2 years	If used in the raw wood industry <sup>3</sup> : Parts - 2 years Labor - 1 year
<b>SLIDER ASSEMBLY</b>				
Slider Box Assembly	All	5 years	1 year	Includes slider pins and slider pin return springs. Does not include the slider wear pad (upper, both sides)
<b>ALL OTHER SUSPENSION AND SLIDER COMPONENTS<sup>6</sup></b>				
Suspension and Slider Components	All	1 year	1 year	Includes slider wear pad (upper) and all other mechanical pin release / activation components
<b>QUIK-DRAW® SLIDER PIN-PULL MECHANISMS</b>				
Air Control Components	HK / HKA / AAZ	1 year	1 year	
Air Actuator	HK / HKA / AAZ	3 years	3 years	
<b>SURELOK® TRAILER RIDE HEIGHT LOCK</b>				
Mechanical Components (Factory Installed Only)	HK / HKA / AANT	3 years	1 year	
Air Control Components (Factory Installed Only)	HK / HKA / AANT	1 year	1 year	
Retrofit Kits (Not Factory-Installed Components)	HK / HKA / AANT	1 year	1 year	Requires verification of kit number and includes retrofit air control kit

<sup>1</sup>Refer to page nine for suspension type definitions.      \*Effective with suspensions built and delivered after 2/1/01.      *Continued on page 12*

<sup>2</sup>For non pre-aligned suspension systems, the installation and final assembly of the suspension pivot connection is performed by the respective trailer OEM. Refer to pages 18 and 19 for further information.

<sup>3</sup>Hendrickson defines the raw wood industry as any forestry application that involves or includes, but is not limited to, logging or chip hauling. INTRAAX AAEDT 30K and AAEDL 30K models are recommended for these applications, and are covered by the standard INTRAAX warranty. AAT 30K and AAL 30K may also be used when written application approval is received from Hendrickson engineering, in which case the standard INTRAAX warranty shall apply. Other INTRAAX and HT models, when used in accordance with Hendrickson publication L707, *Application Guide*, will be covered under the reduced warranty terms noted here. Refer to page 18 for further raw wood warranty information.

<sup>4</sup>For highway use only in single-axle or closed-spaced (for example, 49 inches) tandem applications on van- and reefer-type trailers.

<sup>5</sup>For all vocational trailers, wide-spread and tridem sliders, specialty or spread-axle vans and reefers, and liftable axle suspensions.

<sup>6</sup>Includes suspension and slider components that are not specifically covered in this table and are manufactured and distributed by and for Hendrickson.



COVERAGE TABLE (CONTINUED)

ITEM DESCRIPTION	SUSPENSION TYPE <sup>1</sup>	PARTS	LABOR	COMMENTS (RESTRICTIONS, ETC.)
<b>DOCK HEIGHT STABILIZER</b>				
Mechanical Components (Factory Installed Only)	RS	3 years	1 year	
Air Control Components (Factory Installed Only)	RS	1 year	1 year	
Retrofit Kits (Not Factory-Installed Components)	RS	1 year	N/A	Requires verification of kit number and includes retrofit air control kit
<b>MAXILOK® TRAILER-SUPPORT SYSTEM</b>				
Mechanical Components	HT250U/HT200UM	3 years	1 year	
Air Control Components	HT250U/HT200UM	1 year	1 year	
<b>AFTERMARKET PARTS</b>				
Genuine Hendrickson Replacement Parts (not installed as part of a warranty repair)	All	1 year	N/A	Requires original purchase or installation invoice
<b>UNDER BEAM LIFT™ (UBL™) LIFT AXLE SYSTEM</b>				
All Components	All applicable	1 year	1 year	Proper OEM installation required
<b>DRUM BRAKE COMPONENTS - HENDRICKSON INSTALLED</b>				
Brake Linings and All Brake Related Hardware	All	1 year	1 year	Excludes all normal wear. Warranty void when brake camshaft rotation is opposite of wheel rotation.
Brake Camshaft	All	3 years	1 year	
Cam Tube (Off-Highway Applications)	All	3 years	1 year	Excludes brake camshaft wear
Cam Tube (Highway Applications)	All	3 years	3 years	
Automatic Slack Adjusters	All	5 years <sup>2</sup>	1 year	Off-highway - 1 year parts.
Brake Chamber (Premium 30/30)	All	6 years <sup>2</sup>	1 year	
Brake Chamber (All Others)	All	3 years <sup>2</sup>	1 year	Coverage limited to components sold and installed by Hendrickson Trailer Suspension Systems, but not included in a wheel-end package (excludes normal wear on brake drums)
Brake Drums (Cast) - Not Overheated	All	1 year	1 year	
Brake Drums (Centrifuse)	All	1 year	N/A	

Continued on page 13

<sup>1</sup> Refer to page nine for suspension type definitions.

<sup>2</sup> The suppliers of these non-Hendrickson components may offer warranty coverage beyond the terms listed here. Contact the appropriate supplier for complete details.

**COVERAGE TABLE (CONTINUED)**

ITEM DESCRIPTION	SUSPENSION TYPE <sup>1</sup>	PARTS	LABOR	COMMENTS (RESTRICTIONS, ETC.)
<b>AIR DISC BRAKE COMPONENTS - HENDRICKSON INSTALLED<sup>2</sup></b>				
Brake Pads and All Brake Related Hardware	All	1 year	1 year	Excludes all normal wear.  The suppliers of these non-Hendrickson components may offer warranty coverage beyond the terms listed here. Contact the appropriate supplier for complete details.
Caliper	All	1 year	1 year	
Rotors	All	1 year	1 year	
Brake Chamber	All	1 year	1 year	
<b>WHEEL END PACKAGES<sup>2</sup></b>				
Hub Assembly, Standard Service	AA/HKA/AAZ/Axle	1 year	1 year	Coverage limited to components sold and installed by Hendrickson Trailer Suspension Systems.  †Beginning June '08, includes WEM (Wheel End Monitor)
Hub Assembly, Extended Service (ConMet PreSet)	AA/HKA/AAZ/Axle	5 years	5 years	
Hub Assembly, Extended Service (HVS™) <sup>3</sup>	AA/HKA/AAZ/Axle	3 years	3 years	
Hub Assembly, Extended Service (HLS™) <sup>4</sup>	AA/HKA/AAZ/Axle	5 years	5 years	
Hub Assembly, Extended Service (HUS®) <sup>5, 7 †</sup>	AA/HKA/AAZ/Axle	7 years	7 years	
Hub Assembly, Extended Service (Stemco Platinum Performance System) <sup>6</sup>	AA/HKA/AAZ/Axle	3 years	1 year	
Hub Assembly, Extended Service (Stemco Advantage System) <sup>6</sup>	AA/HKA/AAZ/Axle	5 years	1 year	
Hub Assembly, Extended Service (HXL7™)	AA/HKA/AAZ/Axle	7 years	7 years	
Hubcaps and Gaskets	AA/HKA/AAZ/Axle	1 year	1 year	
Oil Seals	AA/HKA/AAZ/Axle	1 year	1 year	
Wheel Bearings	AA/HKA/AAZ/Axle	1 year	1 year	
Axle Nuts	AA/HKA/AAZ/Axle	1 year	N/A	

*Continued on page 14*<sup>1</sup>Refer to page nine for suspension type definitions.<sup>2</sup>Hendrickson offers air disc brakes only in combination with standard service wheel-end packages. Refer to page 19 for further information.<sup>3</sup>The three year parts and labor warranty terms apply to all on-highway applications. To be eligible for warranty coverage in any off-highway application, HVS™ hub assemblies must be configured with HP spindles and Hendrickson dust shields. When properly configured, the warranty terms are one year parts and labor.<sup>4</sup>The five year parts and labor warranty terms apply to all on-highway applications. To be eligible for warranty coverage in any off-highway application, HLS™ hub assemblies must be configured with HP spindles and Hendrickson dust shields. When properly configured, the warranty terms are three years parts and labor (all off-highway applications except raw wood industry) or three years parts one year labor (raw wood industry applications). Refer to page 18 for further raw wood warranty information.*Footnotes continue on next page*



## COVERAGE TABLE (CONTINUED)

<sup>5</sup>These warranty terms cover units purchased and serviced in the United States and Canada for line-haul, on-highway service applications with a gross axle weight rating up to 23,000 pounds. These applications include auto-haulers, vans, reefers, flatbeds and tank trailers. Coverage may differ in some applications where special written approval must be granted. This warranty does not cover an HUS wheel end which was damaged as a result of improper modification or repair, an accident or failure to adhere to required inspection procedure guidelines. Operating an HUS wheel end in Mexico may void the warranty. Please contact your Hendrickson sales associate to determine if your application is warranted.

<sup>6</sup>Hendrickson no longer offers these Extended Service hub assemblies but will honor valid warranty claims submitted on Extended Service hub assemblies delivered prior to 7/1/06.

<sup>7</sup>Hendrickson no longer offers these Extended Service hub assemblies but will honor valid warranty claims submitted on Extended Service hub assemblies delivered prior to 12/31/09.

*Continued on page 15*



COVERAGE TABLE (CONTINUED)

ITEM DESCRIPTION	SUSPENSION TYPE <sup>1</sup>	PARTS	LABOR	COMMENTS (RESTRICTIONS, ETC.)
<b>TIREMAAX® TIRE INFLATION SYSTEMS</b>				
<b>HENDRICKSON-INSTALLED TIREMAAX WITH HENDRICKSON INSTALLED READY-TO-ROLL® WHEEL ENDS<sup>2</sup>:</b>				
Standard Service Hub Assembly	AA/HKA/AAZ/Axle	3 years	3 years	All internal TIREMAAX axle components installed and assembled by Hendrickson.
ConMet PreSet Hub Assembly	AA/HKA/AAZ/Axle	5 years	3 years	
HLS™ (Hendrickson Long-life System) Hub Assembly	AA/HKA/AAZ/Axle	5 years	3 years	The trailer OEM completes the installation of remaining purchased TIREMAAX components.
QUAANTUM Systems	FX/SL/ZR	5 years	3 years	
HUS® Hub Assembly (Including QUAANTUM)	FX/SL/ZR	7 years	3 years	Warranty terms do not include competitor tire inflation system components.
HXL7™ Hub Assembly	AA/HKA/AAZ/Axle	7 years	7 years	
<b>HENDRICKSON-PREPARED TIREMAAX AXLES WITHOUT WHEEL ENDS<sup>2</sup>:</b>				
Axle Hose, Rotary Union and Hubcap	AA/HKA/AAZ/Axle	3 years <sup>2</sup>	3 years <sup>3, *</sup>	Some TIREMAAX axle components installed by Hendrickson — the trailer OEM completes the installation of remaining purchased TIREMAAX components.  *Labor coverage applies only to Hendrickson installed components (including but not limited to axle vent line, axle hoses, spindle plugs, air control lines and beam grommets).
<b>TIREMAAX CONTROL COMPONENTS:</b>				
Controller Assembly (EC and CP models)	AA/HKA/AAZ/Axle	3 years	3 years	Installation must be per installation recommendations
Wiring Harness	AA/HKA/AAZ/Axle	3 years	1 year	
<b>TIREMAAX EXTERNAL WHEEL-END COMPONENTS:</b>				
Tire Hoses and Tee Fittings	AA/HKA/AAZ/Axle	1 year	1 year	
<b>TIREMAAX AFTERMARKET RETROFIT KIT (AXLE NOT HTIS PREPARED BY HENDRICKSON)<sup>4</sup>:</b>				
All Kit Components	AA/HKA/AAZ/Axle	1 year	N/A	

<sup>1</sup>Refer to page nine for suspension type definitions.

*Continued on page 16*

<sup>2</sup>Includes all internal wheel-end / axle components, including hubcap, rotary union and tubing.

<sup>3</sup>Competitor tire inflation systems are not covered by Hendrickson warranty terms. Contact the respective tire inflation system manufacturer for warranty coverage of competitor make and model.

<sup>4</sup>Axles that are drilled for tire inflation system (Hendrickson or otherwise) that do not follow Hendrickson's recommended drilling procedures (as described in Hendrickson publications L786, *Hendrickson Tire Inflation System - Installation, Service and Troubleshooting Procedures* or L818, *TIREMAAX® Tire Inflation System - Installation, Service and Troubleshooting Procedures*) could void the axle warranty. Unrecommended drilling could cause damage to the axle or other suspension components.



COVERAGE TABLE (CONTINUED)

ITEM DESCRIPTION	SUSPENSION TYPE <sup>1</sup>	PARTS	LABOR	COMMENTS (RESTRICTIONS, ETC.)
<b>HTIS (HENDRICKSON TIRE INFLATION SYSTEM)</b>				
<b>HENDRICKSON-INSTALLED HTIS WITH HENDRICKSON-INSTALLED READY-TO-ROLL® WHEEL ENDS<sup>2</sup>:</b>				
Hub Assembly Standard Service	AA/HKA/AAZ/Axle	3 years	3 years	All internal HTIS axle components installed and assembled by Hendrickson
ConMet PreSet Hub Assembly	AA/HKA/AAZ/Axle	5 years	3 years	The trailer OEM completes the installation of remaining purchased HTIS components
HLS™ (Hendrickson Long-life System) Hub Assembly	AA/HKA/AAZ/Axle	5 years	3 years	Warranty terms do not include competitor tire inflation system components
HUS® Hub Assembly	AA/HKA/AAZ/Axle	5 years	3 years	
<b>HENDRICKSON-PREPARED HTIS AXLES WITHOUT WHEEL ENDS<sup>2</sup>:</b>				
Axle Hose, Rotary Union and Hubcap	AA/HKA/AAZ/Axle	3 years <sup>2</sup>	3 years <sup>3,*</sup>	Some HTIS axle components installed by Hendrickson — the trailer OEM completes the installation of remaining purchased HTIS components  *Labor coverage applies only to Hendrickson installed components (including but not limited to axle vent line, axle hoses, spindle plugs, air control lines and beam grommets)
<b>HTIS ELECTRONIC COMPONENTS:</b>				
Controller Assembly	AA/HKA/AAZ/Axle	3 years	1 year	Installation must be per installation recommendations
Wiring Harness	AA/HKA/AAZ/Axle	3 years	1 year	
<b>HTIS EXTERNAL WHEEL-END COMPONENTS:</b>				
Tire Hoses	AA/HKA/AAZ/Axle	1 year	1 year	

Continued on page 17

<sup>1</sup>Refer to page nine for suspension type definitions.

<sup>2</sup>Includes all internal wheel-end / axle components, including hubcap, rotary union and tubing.

<sup>3</sup>Competitor tire inflation systems are not covered by Hendrickson warranty terms. Contact the respective tire inflation system manufacturer for warranty coverage of competitor make and model.



COVERAGE TABLE (CONTINUED)

ITEM DESCRIPTION	SUSPENSION TYPE <sup>1</sup>	PARTS	LABOR	COMMENTS (RESTRICTIONS, ETC.)
<b>COMPETITOR TIRE INFLATION SYSTEM</b>				
<b>HENDRICKSON-PREPARED AXLES WITHOUT WHEEL ENDS:</b>				
N/A	AA/HKA/AAZ/Axle	N/A	N/A	Hendrickson does not provide warranty coverage for the installation, performance or components of a competitor brand tire inflation system installed on a Hendrickson suspension. Any consequential damages to the Hendrickson suspension resulting from a failure to the competitor brand tire inflation system or components, whether installed by the OEM, repair facility or end-user customer, should be directed to the respective tire inflation system manufacturer for warranty coverage.
<b>HENDRICKSON AXLES NOT PREPARED FOR TIRE INFLATION SYSTEMS<sup>2</sup>:</b>				
N/A	AA/HKA/AAZ/Axle	N/A	N/A	Hendrickson does not provide warranty coverage for the installation, performance or components of a competitor brand tire inflation system installed on a Hendrickson suspension. Any consequential damages to the Hendrickson suspension resulting from a failure to the competitor brand tire inflation system or components, whether installed by the OEM, repair facility or end-user customer, should be directed to the respective tire inflation system manufacturer for warranty coverage.

<sup>1</sup>Refer to page nine for suspension type definitions.

<sup>2</sup>Axles that are drilled for tire inflation system (Hendrickson or otherwise) that do not follow Hendrickson’s recommended drilling procedures (as described in Hendrickson publications L786, *Hendrickson Tire Inflation System - Installation, Service and Troubleshooting Procedures* or L818, *TIREMAAX® Tire Inflation System - Installation, Service and Troubleshooting Procedures*) could void the axle warranty. Unrecommended drilling could cause damage to the axle or other suspension components.



## ADDITIONAL WARRANTY COVERAGE INFORMATION

### RAW WOOD PRODUCT APPLICATIONS

Hendrickson Trailer Suspension Systems defines the raw wood industry as any forestry application that involves or includes, but is not limited to, logging or chip hauling.

Severe and highly unpredictable operating conditions are often encountered in the raw wood product industry. Such rugged applications can cause accelerated wear, deterioration and other problems in suspension systems. For this reason, warranty coverage on certain suspension components used in the raw wood industry differs from the standard warranty coverage on the same components used in less-severe applications.

All INTRAAX® AA 30K models carry the standard INTRAAX warranty (described in the coverage tables on pages 10 through 17) regardless of application. However, written application approval from Hendrickson is required for warranty coverage on INTRAAX AAL 30K and AAT 30K models when used in raw wood product applications. Warranty coverage is not limited for INTRAAX AA 30K models in raw wood product applications when this written application approval is given.

The warranty period for all other suspension components used in raw wood product applications will be up to three years for parts unless otherwise noted (see coverage tables on pages 10 through 17), and one year for labor.

This warranty coverage only affects trailers built on or after November 1, 1999, that operate in the raw wood product industry.

The warranty periods in the coverage table on pages 10 through 17 apply when the suspension has been properly assembled and installed by a trailer original equipment manufacturer (OEM), properly maintained (as described in all applicable Hendrickson publications), and used in the recommended application and within the rated capacities (as described in the Hendrickson *Application Guide*, publication L707). Coverage may differ on some items used in applications for which special written approval from Hendrickson has been granted. If you have any questions about the information contained herein, please contact the Hendrickson Trailer Suspension Systems technical service department at 800-455-0043 in the United States or 800-668-5360 in Canada.

### QUIK-ALIGN® PIVOT ASSEMBLY

Original equipment manufacturers (OEMs) have the option of ordering Hendrickson suspensions in one of two states: pre-aligned (available only on VANTRAAX® slider suspension systems and QUAANTUM slider suspension systems) or standard (non pre-aligned - available on all Hendrickson suspension systems). In either state, the pivot connection is warranted for one year parts and labor. The difference is in application and is as follows:

Hendrickson's pre-aligned pivot connection warranty applies to *all* QUIK-ALIGN® pivot assemblies since installation and final assembly of the pivot connection is performed by Hendrickson.

Hendrickson's standard (non pre-aligned) pivot connection warranty coverage applies only to QUIK-ALIGN pivot assemblies where proper installation and final assembly were performed. The installation and final assembly of the suspension pivot connection is performed by the respective trailer OEM. Proper installation includes, but is not limited to, the use and removal of the Torx® head of the pivot bolt to ensure proper pivot assembly torque along with the proper mounting of the alignment washers/collars (refer to Hendrickson publications L341, *INTRAAX® Installation Procedures; L577, HT/HS/HK Installation Procedures*, and L579, *Alignment Procedures*, for additional assembly requirements). Pivot assembly components must be available for review for warranty consideration. Pivot assemblies that are missing the plastic band, or other reuse indicator, on the pivot bolt hardware are not covered.



## ADDITIONAL WARRANTY COVERAGE INFORMATION (CONTINUED)

### PRE-ALIGNED VANTRAAX® AND QUANTUM SL WARRANTY STATEMENT

Pre-aligned slider systems are built on precision fixtures and feature axles that are perpendicular to the slider box and parallel to each other. Documented measurement data confirms alignment and is shipped with each slider suspension system built with this option.

The trailer OEM is responsible for the total trailer alignment and all facets of construction required to accommodate the slider suspension system, such as trailer frame construction, proper placement of the kingpin, proper body rail installation and proper body rail spacing. Hendrickson provides body rail installation and spacing recommendations in publication L341, *Installation Procedures*, and in various installation drawings.

Hendrickson does not recommend additional alignment adjustments by the dealer or distributor prior to delivery to the final customer (i.e., fleet, owner operator) and will not reimburse for any related parts or labor expenses from such additional adjustments. Hendrickson warrants the perpendicularity and parallelism of the axles relative to the slider box itself, based on established Hendrickson specifications, only until delivery of the pre-aligned slider suspension system to the trailer OEM.

If a performance concern is expressed by the customer regarding a pre-aligned slider suspension system, the customer or trailer OEM dealer should contact the Hendrickson technical service department at 800 455-0043 in the United States (or fax to 330 489-0494) or 800 668-5360 in Canada prior to performing any adjustments or repairs. Hendrickson will guide and provide assistance to the customer, dealer and/or repair facility through validation checks and will provide corrective actions as necessary.

### AIR DISC BRAKE WARRANTY STATEMENT

Hendrickson offers air disc brakes only in combination with our standard service wheel-end package. Air disc brake packages installed by Hendrickson will carry a limited one-year parts and labor warranty, excluding all normal wear.

Hendrickson publication L924 only addresses the Hendrickson warranty position on air disc brakes combined with extended service wheel-ends shipped prior to September 1, 2006.

---

[www.hendrickson-intl.com](http://www.hendrickson-intl.com)



Trailer Suspension Systems  
250 Chrysler Drive, Unit #3  
Brampton, ON Canada L6S 6B6  
905.789.1030  
Fax 905.789.1033

Trailer Suspension Systems 866.RIDEAIR (743.3247)  
2070 Industrial Place SE 330.489.0045  
Canton, OH 44707-2641 USA Fax 800.696.4416

Hendrickson Mexicana  
Av. Industria Automotriz #200  
Parque Industrial Sliva Aeropuerto  
Apodaca, N.L., México C.P. 66600  
+52 (81) 8288.1300  
Fax +52 (81) 8288.1301