

# **RAISED-CENTER AXLE INTRAAX®**

## DATA SHEET

LIT NO: L847

DATE: March 2005

REVISION: A

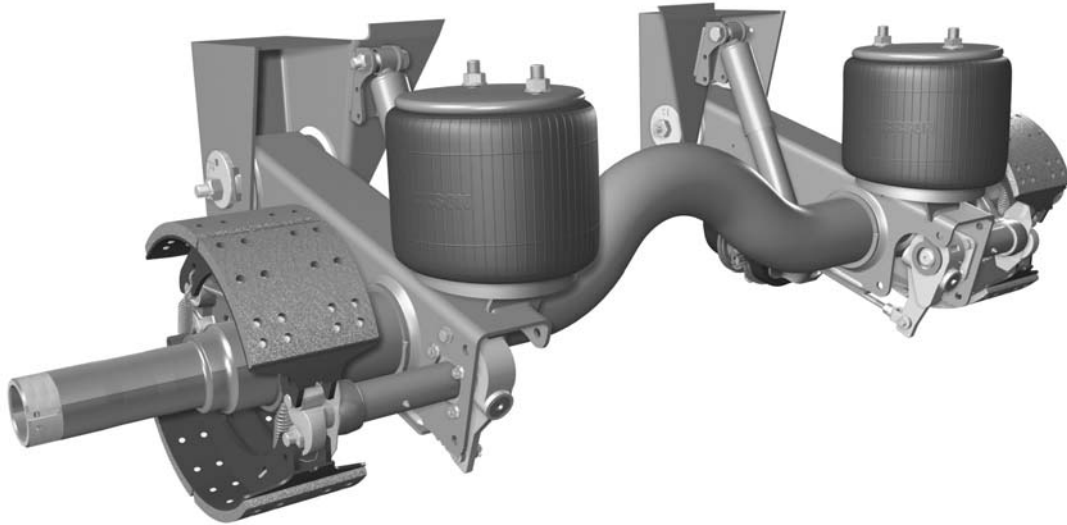

## RAISED-CENTER AXLE APPLICATIONS REAP THE BENEFITS OF SYSTEM INTEGRATION

Introduction of the Raised-center Axle INTRAAX® brings all the benefits of an integrated trailer suspension system to operators running rear-discharge tankers.

Worldwide, fleet executives and owner operators put their trust in INTRAAX. They demand superior performance and benefits including weight advantages, low maintenance and a smooth, stable ride — and INTRAAX delivers.

For raised-center axle applications, INTRAAX slashes weight by about 100 pounds compared to previous models while strengthening the axle connections and increasing overall system durability.

The system offers suspension capacities\* of 23,000- and 25,000-pound for 77.5- and 71.5-inch tracks in top-mount configurations and a range of ride heights from 13.5 to 19 inches.

Suspension Capacities*	Tracks	Ride Heights
23,000 lbs. 25,000 lbs.	71.5 and 77.5 inch	13.5 to 19 inch

The patented INTRAAX system features exceptionally tight axle tolerances to help stretch fuel mileage and tire life, as well as the first standard trailer Cam Tube System™ to reduce S-cam maintenance.

**For additional information on the Raised-center Axle INTRAAX, contact your trailer dealer or a Hendrickson representative at 866-RIDEAIR (743-3247).**

*\*Axle rated only for 23,000 pounds. Brakes rated separately.*

# INTRAAX® FEATURES AND BENEFITS BOOST TRAILER PRODUCTIVITY AND VALUE

## STANDARD FEATURES:

- TRI-FUNCTIONAL® Bushing, rigid trailing arm and solid axle connection provide the ideal combination of ride softness and stability
- Short 10-inch S-cam reduces windup and bushing wear for responsive, consistent stopping power
- Industry's first standard trailer Cam Tube System™ enhances alignment and helps extend life of brake components
- Brake hardware welded to trailing arms rather than axle minimizes axle stress
- Patented axle wrap and window weld for optimal structural integrity
- Leading structural warranty\* supported by wide network of OEMs, dealers, distributors and outstanding Hendrickson technical support staff

\*Applicable in most geographic areas

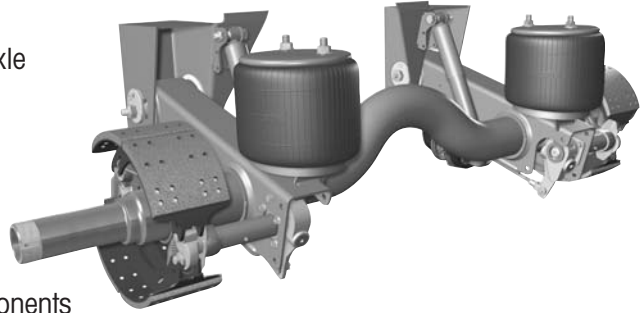

## OPTIONS:

- READY-TO-ROLL® wheel-end options reduce weight, enhance durability and lower maintenance
  - ✓ Hendrickson Long-life System™ (HLS™) with a five-year limited warranty provides an affordable approach with a choice of ductile iron, ADI or aluminum hubs
- TIREMAAX® tire inflation system assists in your efforts to maximize tire life and maintain peak fuel mileage
- HXS® (Hendrickson extended service) brakes and wide HXS brakes extend intervals between brake service

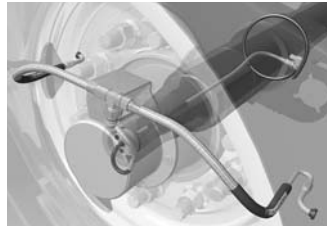

TIREMAAX tire inflation system

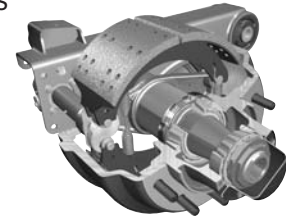

HLS wheel end

Call your trailer dealer or Hendrickson at 866-RIDEAIR (743-3247) to move up to INTRAAX for your raised-center axle applications.

[www.hendrickson-intl.com](http://www.hendrickson-intl.com)

# HENDRICKSON

Trailer Suspension Systems  
250 Chrysler Drive, Unit #3  
Brampton, ON L6S 6B6 Canada  
905.789.1030  
Fax 905.789.1033

Trailer Suspension Systems 866.RIDEAIR (743.3247)  
2070 Industrial Place SE 330.489.0045  
Canton, OH 44707-2600 USA Fax 800.696.4416

Trailer Suspension Systems  
Ave. Rogelio González Caballero #850-B  
Parque Industrial STIVA Aeropuerto  
Apodaca, N.L., C.P. 66600 Mexico  
(52) 81 8156 1300  
Fax (52) 81 8156 1301