

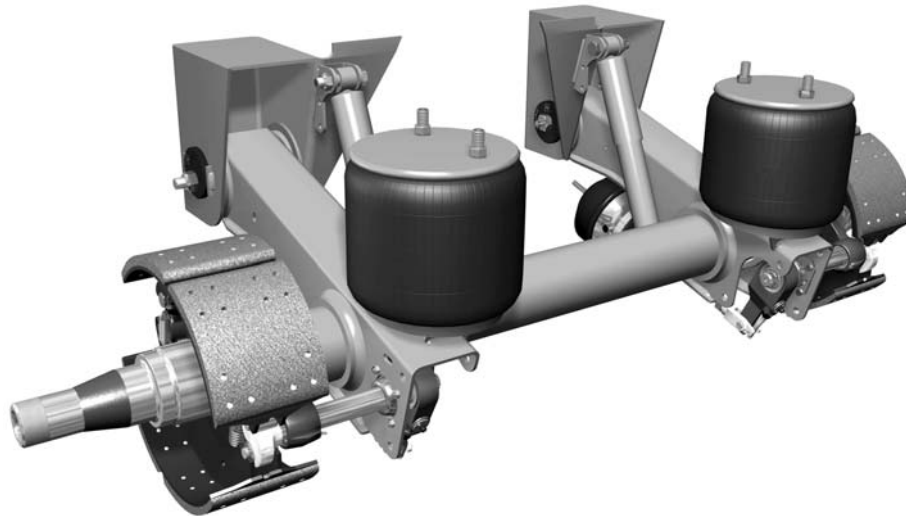

AA230TC WITH CAMBERED AXLE

DATA SHEET
LIT NO: L742
DATE: July 2000



Grain haulers reap benefits from cambered axle INTRAAX®

Hendrickson introduces an INTRAAX® suspension system with a cambered axle specifically for hopper applications. INTRAAX allows grain trailer operators with a preference for cambered axles to achieve all of the benefits of the world's premier integrated suspension-axle-brake system.

In response to requests from grain haulers for a cambered axle, Hendrickson developed this option for top-mount INTRAAX suspension systems. Ride heights range from 13.5 to 17 inches for this 23,000-pound capacity system with axles cambered to an industry standard of 20 to 40 minutes.

For carriers seeking to optimize performance, INTRAAX reduces weight while providing exceptional ride quality, minimum maintenance and maximum productivity.

For additional information, call Hendrickson at (330) 489-0045 or visit our web site at www.hendrickson-intl.com.



Capacity
23,000 pounds

Ride Heights
13.5 to 17 inches

Spindle
HN or HP

Application
Hoppers

INTRAAX® advantage

INTRAAX combines cutting-edge design with advanced manufacturing technology. The result is a system that slashes weight while improving strength, durability and performance.

All the value enhancing options available on INTRAAX are offered in the cambered axle version including a wide variety of brake types and linings and READY-TO-ROLL® selections.

Features and Benefits



Axle wrap technology

- Unsurpassed weight savings for maximum payload
- Cambered axle with controlled toe for increased fuel economy, improved tire life and arrow-straight tracking
- Low maintenance, extended-service wheel-end packages
- Patented axle-wrap technology and beam-mounted brake hardware for outstanding durability and brake performance
- TRI-FUNCTIONAL® BUSHING in unison with rigid trailing arms and solid axle connection delivers the ideal balance of ride softness and control
- QUIK-ALIGN® pivot connection for fast and easy axle realignment
- Unparalleled Hendrickson support team



TRI-FUNCTIONAL® BUSHING

Warranty

- 10-year/1,000,000-mile warranty on axle/beam connection
- 5-year/500,000-mile structural warranty

Note: Axle warranty for the cambered axle is only valid in grain hopper applications

**For additional information, call Hendrickson at (330) 489-0045
or visit our website at www.hendrickson-intl.com.**

www.hendrickson-intl.com



Trailer Suspension Systems
250 Chrysler Drive, Unit #3
Brampton, ON Canada L6S 6B6
905.789.1030
Fax 905.789.1033

Trailer Suspension Systems 866.RIDEAIR (743.3247)
2070 Industrial Place SE 330.489.0045
Canton, OH 44707-2641 USA Fax 800.696.4416

Trailer Suspension Systems
Av. Industria Automotriz #200
Parque Industrial Silva Aeropuerto
Apodaca, N.L., México C.P. 66600
(52) 81 8288 1300
Fax (52) 81 8288 1301