

PRODUCT ANNOUNCEMENT

INTRAAX® AANL 23K and AAL 23K / 25K Bolt-on Frame Brackets

LIT NO: L1127

DATE: December 2008

To further compliment the lightweight INTRAAX® AANL 23K suspension, Hendrickson Trailer Suspension Systems is announcing the availability of a bolt-on frame bracket option for 6.5- through 9-inch ride heights. AANL 23K suspensions are ideal for low ride-height applications. As well, the AANL 23K saves approximately 75 pounds in suspension weight when converting from the AAL 23K.

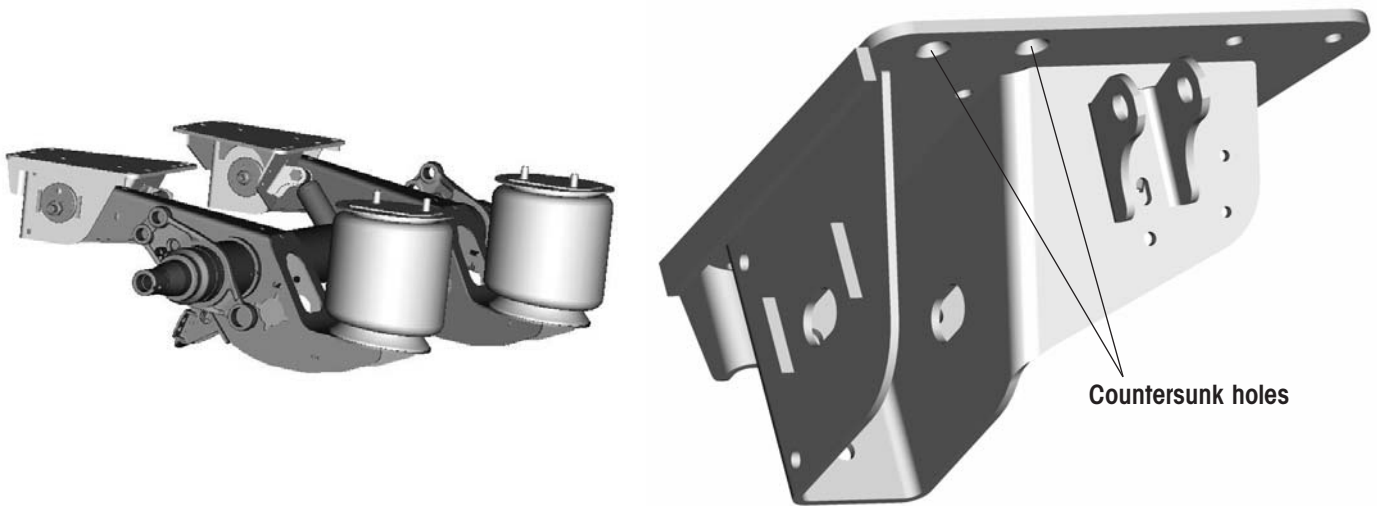

Designed into the AANL frame brackets and as an improvement to the AAL frame brackets are two countersunk holes. These were specifically added to low ride height suspensions to provide additional clearance between the suspension's trailing arm and the frame bracket mounting hardware. The countersunk holes are only included in the 6.5 to 9-inch ride height range. Hendrickson will supply the countersunk bolts when ordered as part of the AANL or AAL suspension assembly and when ordered as an aftermarket frame bracket kit.

For additional information, call 1-866-RIDEAIR (743-3247) or visit www.hendrickson-intl.com

www.hendrickson-intl.com

HENDRICKSON

Trailer Suspension Systems
250 Chrysler Drive, Unit #3
Brampton, ON Canada L6S 6B6
905.789.1030
Fax 905.789.1033

Trailer Suspension Systems 866.RIDEAIR (743.3247)
2070 Industrial Place SE 330.489.0045
Canton, OH 44707-2641 USA Fax 800.696.4416

Trailer Suspension Systems
Av. Industria Automotriz #200
Parque Industrial Stiva Aeropuerto
Apodaca, N.L., México C.P. 66600
+52 81 8288 1300
Fax +52 81 8288 1301