

SELECTION GUIDE

RS™ Series Frame Hangers

LIT NO: 45745-037

DATE: July 2010

REVISION: C

RS 400/403/460/463

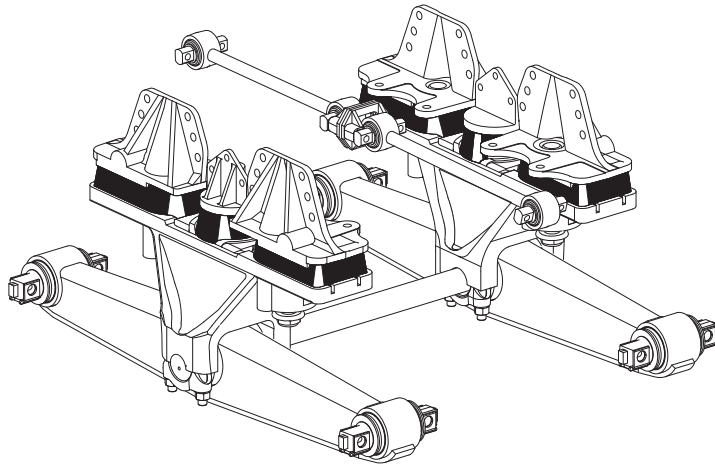

RS 480/503/520/523

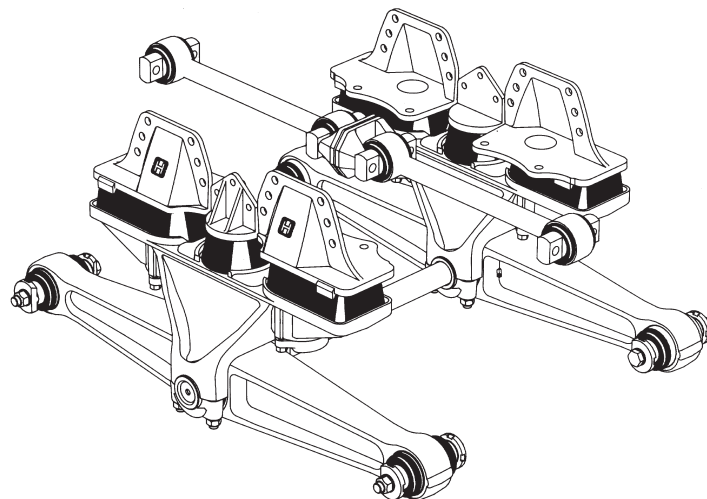

CONTENTS

	PAGE
Introduction	2
Guide Instructions	2
Frame Hanger Design	3
Vehicles built in 1990 to Present	4
Vehicles built in 1990 to 1996	5
Vehicles built in 1983 to 1990	7
Vehicles built before 1983	9
Heavy-duty Frame Hanger	12

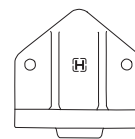
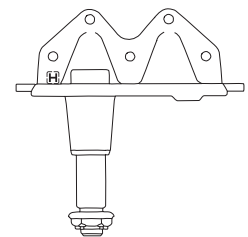
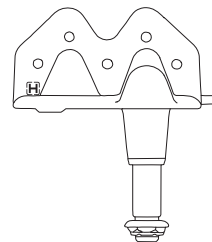
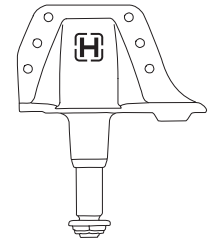
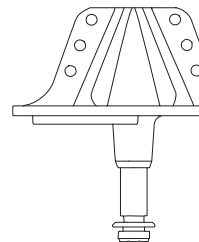

Common Drill Patterns and Castings

■ Introduction

This RS Frame Hanger Selection Guide is intended to aid in the proper identification and aftermarket replacement of originally equipped RS drilled hangers and heavy duty center hangers. It lists common drill patterns and castings that were in use prior to 1983, from 1983 to 1990 and from 1990 to date. On glider kit installations, where we do not have control of hanger usage, ensure that the proper hangers are used for the glider frame width.

Refer to RS suspension Publication Nos. SP-166, 17730-064, 17730-190 and 17730-213 for additional information on proper maintenance, service, repair and rebuild instructions.

■ Guide Instructions

STEP 1 Obtain the frame hanger **casting part number**.

STEP 2 Identify the **truck manufacturer**.

STEP 3 Measure the outside to outside **frame width**.

STEP 4 If needed, refer to the **hole diameters** (Dimension A) and where available, **the measurement** taken from the bottom of the frame to the first line of holes of the hanger (Dimension B).

STEP 5 In some cases, where the vehicle manufacturer has changed drill patterns, but still use the same casting number, see the date of this changeover.

- Always use **hole location dimensions** as a final check.

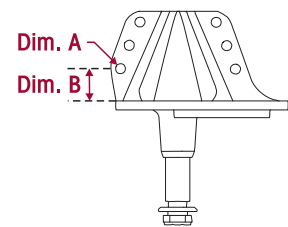

NOTE

For replacement RS hangers, Hendrickson recommends a minimum 5/8" Grade 8 bolt with Grade C locknut and hardened washers be used to attach frame hangers to the main frame of the vehicle. With older model vehicles this may require that the holes in the frame be enlarged to accommodate the 5/8" fasteners.

For any casting number or a truck manufacturer not listed, contact Hendrickson Truck Parts toll-free at 866-755-5968 (email:truckparts@hendrickson-intl.com).



■ Frame Hanger Design

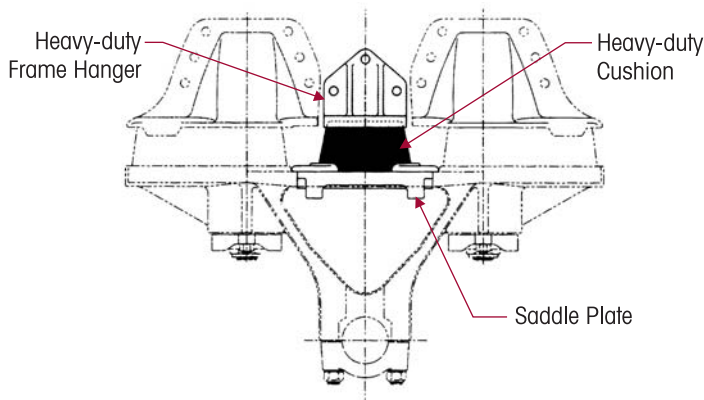
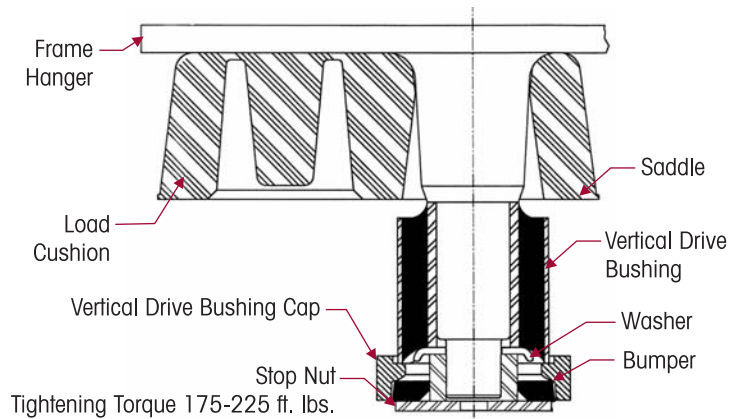
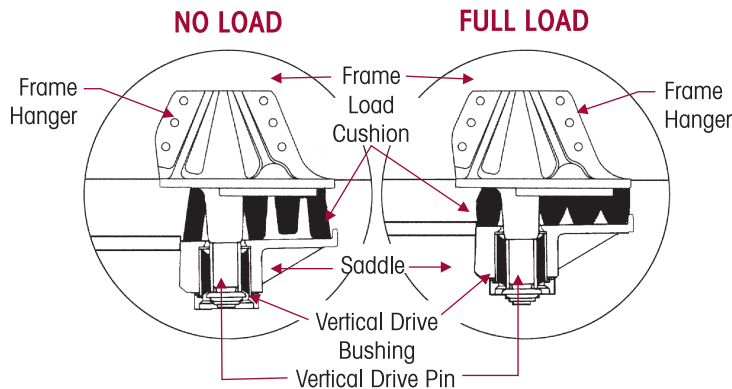

LOAD CUSHIONS

The RS Series suspensions are equipped with standard four rubber load cushions. Each cushion has an inner cross bar that helps support the load when the vehicle is loaded. An empty vehicle is supported only by the outer edges of the cushions.

VERTICAL DRIVE PIN

The RS Series frame hangers have vertical drive pins that extend down through the load cushions and are secured to rubber vertical drive bushings in the saddle.

REBOUND CONTROL STOP KIT

A rebound control stop kit consisting of special stop nuts and elastomer bumpers is available to increase stability in high center of gravity or offset loading vehicles. Rebound control stop kit is optional for 40,000 through 48,000 lbs. capacities and standard on 52,000 lbs. units.

Rebound Control Stop Kit

Kit No.	
31005-001	One Side
31005-002	Both Sides

HEAVY-DUTY LOAD CUSHION KIT

The heavy-duty load cushion kit for increased stability consists of an additional round center cushion and related frame hanger for each side of the chassis. Heavy-duty Load Cushion Kit is optional for 40,000 lbs. capacities and standard on 46,000 through 52,000 lbs. units.

Heavy-duty Load Cushion Kit

Kit No.	Frame Width
20681-072	34"
20681-077	34½"

VEHICLES BUILT FROM 1990 TO PRESENT

FITS FRAME WIDTH OF 33.94" TO 34.19" (0.09" OFFSET)

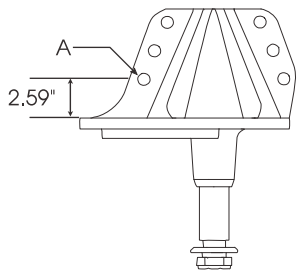

CASTING NO.
57063-000
(LHF/RHR)

OEM	DIMENSION A (IN INCHES)	PART NO.
Duplex Truck	0.66	57065-002
Emergency One	0.66	57065-002
Ford	0.83	57065-001
Freightliner	0.66	57065-002
HME	0.66	57065-002
Kenworth	0.66	57065-002
Mack	0.66	57065-002
Marmon	0.66	57065-002
International (Pre-1997)	0.66	57065-002
International	0.66	57065-006
Oshkosh	0.66	57065-002
Peterbilt	0.66	57065-003
Peter Pirsch	0.66	57065-002
Pierce	0.66	57065-002
Savage Mfg.	0.66	57065-002
Sutphen	0.66	57065-002
Western Star	0.66	57065-002

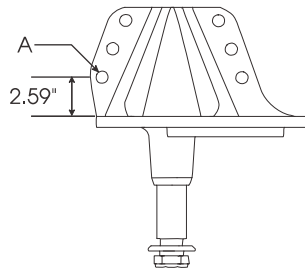

CASTING NO.
57066-000
(RHF/LHR)

Duplex Truck	0.66	57068-002
Emergency One	0.66	57068-002
Ford	0.83	57068-001
Freightliner	0.66	57068-002
HME	0.66	57068-002
Kenworth	0.66	57068-002
Mack	0.66	57068-002
Marmon	0.66	57068-002
International (Pre-1997)	0.66	57068-002
International	0.66	57068-006
Oshkosh	0.66	57068-002
Peterbilt	0.66	57068-003
Peter Pirsch	0.66	57068-002
Pierce	0.66	57068-002
Savage Mfg.	0.66	57068-002
Sutphen	0.66	57068-002
Western Star	0.66	57068-002

FITS FRAME WIDTH OF 34.44" TO 34.69" (0.34" OFFSET)

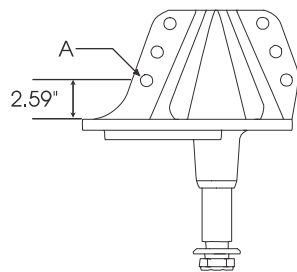

CASTING NO.
57057-000
(LHF/RHR)

OEM	DIMENSION A (IN INCHES)	PART NO.
Ford	0.83	57059-001
Freightliner	0.66	57059-003
Mack	0.66	57059-002
International (Pre-1997)	0.66	57059-002
International	0.66	57059-005
Peterbilt	0.66	57059-003
Volvo GM	0.66	57059-002

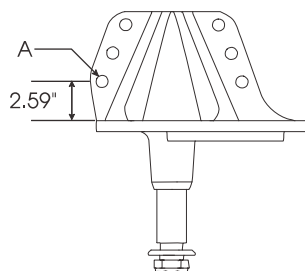

CASTING NO.
57060-000
(RHF/LHR)

Ford	0.83	57062-001
Freightliner	0.66	57062-003
Mack	0.66	57062-002
International (Pre-1997)	0.66	57062-002
International	0.66	57062-005
Peterbilt	0.66	57062-003
Volvo GM	0.66	57062-002



VEHICLES BUILT FROM 1990 TO PRESENT

FITS FRAME WIDTH OF 34.75" TO 35.00" (0.50" OFFSET)

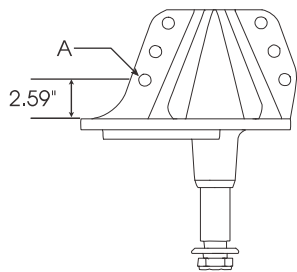

CASTING NO. 57051-000 (LHF/RHR)

OEM	DIMENSION A (IN INCHES)	PART NO.
Ford	0.83	57053-001
International	0.83	57053-001
Osterlund	0.66	57053-002
Spartan	0.66	57053-002

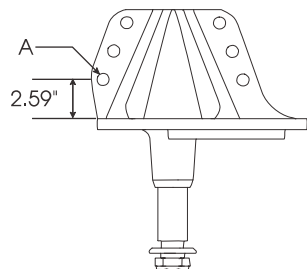

CASTING NO. 57054-000 (RHF/LHR)

Ford	0.83	57056-001
International	0.83	57056-001
Osterlund	0.66	57056-002
Spartan	0.66	57056-002

VEHICLES BUILT FROM 1990 TO 1996

FITS FRAME WIDTH OF 33.94" TO 34.19" (0.09" OFFSET)

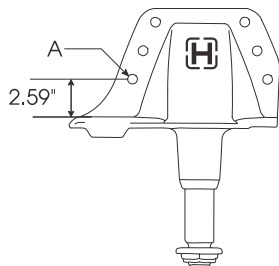

CASTING NO. 57063-000 (LHF/RHR) Replaced 48219-000 in 1994

OEM	DIMENSION A (IN INCHES)	PART NO.	REPLACEMENT PART NO.
Duplex Truck	0.66	48220-002	57065-002
Emergency One	0.66	48220-002	57065-002
Ford	0.83	48220-001	57065-001
Freightliner	0.66	48220-002	57065-002
HME	0.66	48220-002	57065-002
Kenworth	0.66	48220-002	57065-002
Mack	0.66	48220-002	57065-002
Marmon	0.66	48220-002	57065-002
International	0.66	48220-002	57065-002
Oshkosh	0.66	48220-002	57065-002
Peterbilt	0.66	48220-003	57065-003
Peter Pirsch	0.66	48220-002	57065-002
Pierce	0.66	48220-002	57065-002
Savage Mfg.	0.66	48220-002	57065-002
Sutphen	0.66	48220-002	57065-002
Western Star	0.66	48220-002	57065-002

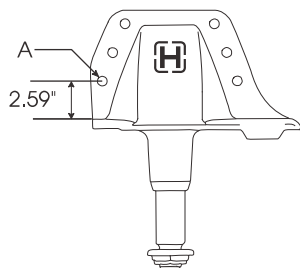

CASTING NO. 57066-000 (RHF/LHR) Replaced 48221-000 in 1994

Duplex Truck	0.66	48222-002	57068-002
Emergency One	0.66	48222-002	57068-002
Ford	0.83	48222-001	57068-001
Freightliner	0.66	48222-002	57068-002
HME	0.66	48222-002	57068-002
Kenworth	0.66	48222-002	57068-002
Mack	0.66	48222-002	57068-002
Marmon	0.66	48222-002	57068-002
International	0.66	48222-002	57068-002
Oshkosh	0.66	48222-002	57068-002
Peterbilt	0.66	48222-003	57068-003
Peter Pirsch	0.66	48222-002	57068-002
Pierce	0.66	48222-002	57068-002
Savage Mfg.	0.66	48222-002	57068-002
Sutphen	0.66	48222-002	57068-002



VEHICLES BUILT FROM 1990 TO 1996

FITS FRAME WIDTH OF 34.44" TO 34.69" (0.34" OFFSET)

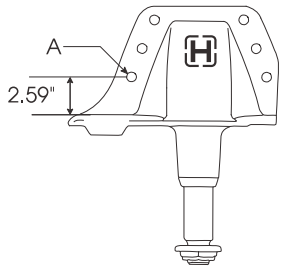

CASTING NO. 57057-000 (LHF/RHR) <i>Replaced</i> 48215-000 <i>in 1994</i>	OEM	DIMENSION A (IN INCHES)	PART NO.	REPLACEMENT
				PART NO.
	Ford	0.83	48216-001	57059-001
	Freightliner	0.66	48216-003	57059-003
	Mack	0.66	48216-002	57059-002
	International	0.66	48216-002	57059-002
	Peterbilt	0.66	48216-003	57059-003
	Volvo GM	0.66	48216-002	57059-002

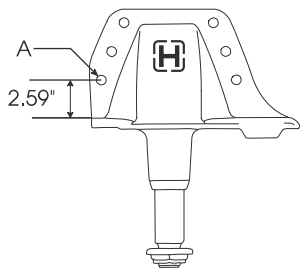

CASTING NO. 57060-000 (RHF/LHR) <i>Replaced</i> 48217-000 <i>in 1994</i>	OEM	DIMENSION A (IN INCHES)	PART NO.	REPLACEMENT
				PART NO.
	Ford	0.83	48218-001	57062-001
	Freightliner	0.66	48218-003	57062-003
	Mack	0.66	48218-002	57062-002
	International	0.66	48218-002	57062-002
	Peterbilt	0.66	48218-003	57062-003
	Volvo GM	0.66	48218-002	57062-002

FITS FRAME WIDTH OF 34.75" TO 35.00" (0.50" OFFSET)

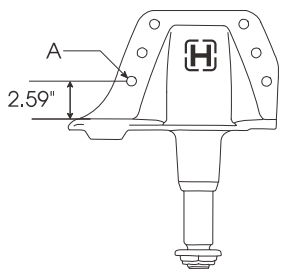

CASTING NO. 57051-000 (LHF/RHR) <i>Replaced</i> 48211-000 <i>in 1994</i>	OEM	DIMENSION A (IN INCHES)	PART NO.	REPLACEMENT
				PART NO.
	Ford	0.83	48212-001	57053-001
	International	0.83	48212-001	57053-001
	Osterlund	0.66	48212-002	57053-002
	Spartan	0.66	48212-002	57053-002

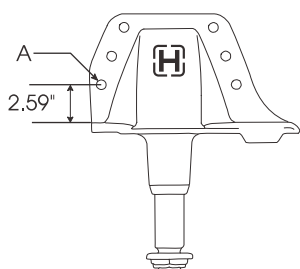

CASTING NO. 57054-000 (RHF/LHR) <i>Replaced</i> 48213-000 <i>in 1994</i>	OEM	DIMENSION A (IN INCHES)	PART NO.	REPLACEMENT
				PART NO.
	Ford	0.83	48214-001	57056-001
	International	0.83	48214-001	57056-001
	Osterlund	0.66	48214-002	57056-002
	Spartan	0.66	48214-002	57056-002



VEHICLES BUILT FROM 1983 TO 1990

FITS FRAME WIDTH OF 33.94" TO 34.19" (0.09" OFFSET)

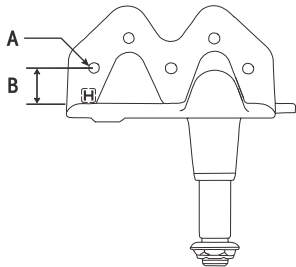

CASTING NO. 47083-000 (LHF/RHR) Undrilled Assy. 47355-003

Table with 5 columns: OEM, DIMENSION A (IN INCHES), DIMENSION B (IN INCHES), PART NO. Lists OEMs like Advance Mixer, Duplex Truck, Ford, etc.

*International Usage started in 1989

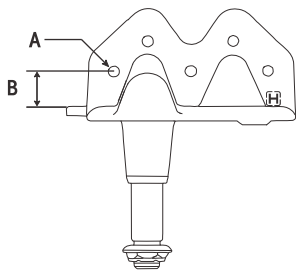

CASTING NO. 47085-000 (RHF/LHR) Undrilled Assy. 47355-004

Table with 5 columns: OEM, DIMENSION A (IN INCHES), DIMENSION B (IN INCHES), PART NO. Lists OEMs like Advance Mixer, Duplex Truck, Ford, etc.

*International Usage started in 1989

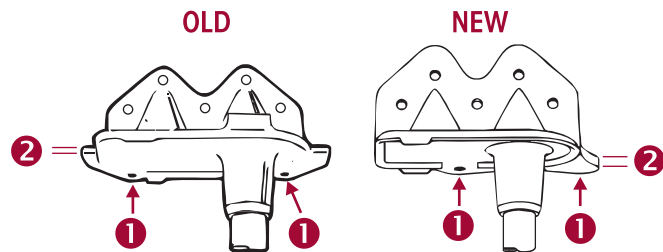

1 OLDER Vehicles

May require two (2) new holes to be drilled into the frame inner gusset to accommodate the replacement RS hanger drilling pattern.

2 NEW Replacement Hangers

Should be used in sets, i.e., if the right-hand front hanger is being replaced, then the right-hand rear hanger should also be replaced. This is due to the mounting height difference, the replacement hanger is 1/8" thicker than the old hanger.



VEHICLES BUILT FROM 1983 TO 1990

FITS FRAME WIDTH OF 34.44" TO 34.69" (0.34" OFFSET)

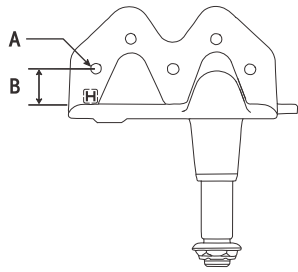

CASTING NO.
47087-000
(LHF/RHR)

Undrilled Assy.
47355-005

OEM	DIMENSION A (IN INCHES)	DIMENSION B (IN INCHES)	PART NO.	REPLACEMENT PART NO.
Crane Carrier	0.66	2.25	47088-002	
Ford	0.83	2.59	47088-001	
Freightliner	0.66	2.59	47088-003	
GMC	0.66	2.25	47088-002	
Mack	0.66	2.25	47088-002	
International*	0.66	2.25	47088-002	
Peterbilt	0.66	2.59	47088-003	
Volvo GM	0.66	2.25	47088-002	

*International Usage started in 1989

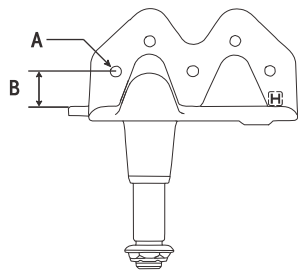

CASTING NO.
47089-000
(RHF/LHR)

Undrilled Assy.
47355-006

Crane Carrier	0.66	2.25	47090-002	
Ford	0.83	2.59	47090-001	
Freightliner	0.66	2.59	47090-003	
GMC	0.66	2.25	47090-002	
Mack	0.66	2.25	47090-002	
International*	0.66	2.25	47090-002	
Peterbilt	0.66	2.59	47090-003	
Volvo GM	0.66	2.25	47090-002	

*International Usage started in 1989

FITS FRAME WIDTH OF 34.75" TO 35.00" (0.50" OFFSET)

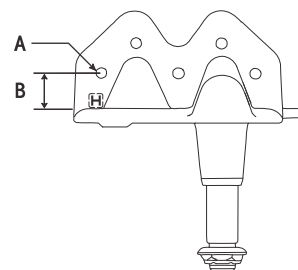

CASTING NO.
46759-000
(LHF/RHR)

Undrilled Assy.
47355-009

OEM	DIMENSION A (IN INCHES)	DIMENSION B (IN INCHES)	PART NO.	REPLACEMENT PART NO.
Ford (Pre 1983)	0.76	2.36	46800-001	48082-035
Ford	0.83	2.59	46800-003	48082-025
International*	0.83	2.59	46800-003	48082-025
Osterlund	0.76	2.36	46800-001	48082-035
Spartan	0.76	2.36	46800-001	48082-035

*International Usage started in 1989

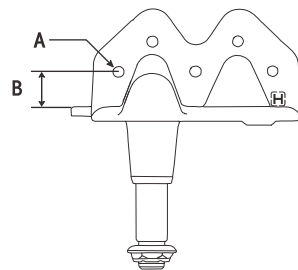

CASTING NO.
46758-000
(RHF/LHR)

Undrilled Assy.
47355-010

Ford (Pre 1983)	0.76	2.36	46801-001	48082-036
Ford	0.83	2.59	46801-003	48082-026
International*	0.83	2.59	46801-003	48082-026
Osterlund	0.76	2.36	46801-001	48082-036
Spartan	0.76	2.36	46801-001	48082-036

*International Usage started in 1989



VEHICLES BUILT BEFORE 1983

FITS FRAME WIDTH OF 33.94" TO 34.19" (0.09" OFFSET)

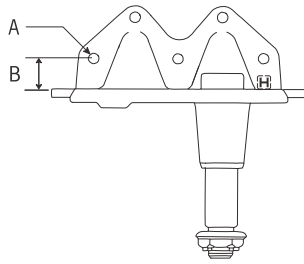

CASTING NO. **47083-000**
(LHF/RHR)
Replaces
09494-000

Undrilled Assy.
47355-003
Replaces
31675-001

OEM	DIMENSION A (IN INCHES)	DIMENSION B (IN INCHES)	PART NO.	REPLACEMENT PART NO.
Advance Mixer	0.66	2.25	21115-010	47084-002
Chrysler	0.53	1.88	21115-014	47084-004
Diamond Reo	0.66	1.88	21115-012	47084-004
Duplex Truck	0.66	2.25	21115-010	47084-002
Ford (C Series)	0.56	1.81	◆ 21860-002	
Freightliner	0.66	2.25	21115-010	47084-002
GMC (Pre 1976)	0.53	1.88	21115-015	47084-004
HME	0.66	1.88	21115-004	47084-004
IHC (Pre 1976)	0.59	1.88	21115-002	47084-002
IHC*	0.66	2.25	21115-024	47084-006
Kenworth	0.66	2.25	21115-010	47084-002
Mack Canada	0.53	1.88	21115-005	47084-004
Marmon	0.53	1.88	21115-005	47084-004
Oshkosh (Pre 1976)	0.53	1.88	21115-009	47084-004
Oshkosh	0.66	2.25	21115-010	47084-002
Peterbilt	0.66	2.25	21115-010	47084-002
Peter Pirsch	0.66	2.25	21115-010	47084-002
Riteway	0.66	2.25	21115-010	47084-002
Savage Mfg.	0.66	1.88	21115-004	47084-004
Sutphen	0.66	2.25	21115-010	47084-002
Western Star	0.66	2.25	21115-010	47084-002
White (Pre 1976)	0.53	1.88	21115-009	47084-004

*International (IHC) Usage thru 1988

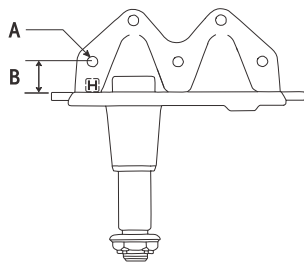

CASTING NO. **47085-000**
(RHF/LHR)
Replaces
09493-000

Undrilled Assy.
47355-004
Replaces
31675-002

Advance Mixer	0.66	2.25	21116-010	47086-002
Chrysler	0.53	1.88	21116-014	47086-004
Diamond Reo	0.66	1.88	21116-012	47086-004
Duplex Truck	0.66	2.25	21116-010	47086-002
Ford (C Series)	0.56	1.81	◆ 21861-002	
Freightliner	0.66	2.25	21116-010	47086-002
GMC (Pre 1976)	0.53	1.88	21116-015	47086-004
HME	0.66	1.88	21116-004	47086-004
IHC (Pre 1976)	0.59	1.88	21116-020	47086-004
IHC*	0.66	2.25	21116-029	47086-006
Kenworth	0.66	2.25	21116-010	47086-002
Mack Canada	0.53	1.88	21116-005	47086-004
Marmon	0.53	1.88	21116-005	47086-004
Oshkosh (Pre 1976)	0.53	1.88	21116-009	47086-004
Oshkosh	0.66	2.25	21116-010	47086-002
Peterbilt	0.66	2.25	21116-010	47086-002
Peter Pirsch	0.66	2.25	21116-010	47086-002
Riteway	0.66	2.25	21116-010	47086-002
Savage Mfg.	0.66	1.88	21116-004	47086-004
Sutphen	0.66	2.25	21116-010	47086-002
Western Star	0.66	2.25	21116-010	47086-002
White (Pre 1976)	0.53	1.88	21116-010	47086-006

*International (IHC) Usage thru 1988

◆ Obsolete, contact Hendrickson Truck Parts for available options.



VEHICLES BUILT BEFORE 1983

FITS FRAME WIDTH OF 33.94" TO 34.19" (0.09" OFFSET)

		OEM	DIMENSION A (IN INCHES)	DIMENSION B (IN INCHES)	PART NO.	REPLACEMENT PART NO.
	CASTING NO. 47083-000 (LHF/RHR) <i>Replaces</i> 23603-000 Undrilled Assy. 47355-003 <i>Replaces</i> 31675-006	White Autocar (Pre 1976)	0.53	1.88	21221-001	47084-004
		Mack	0.53	1.88	21221-003	47084-004
	CASTING NO. 47085-000 (RHF/LHR) <i>Replaces</i> 23604-000 Undrilled Assy. 47355-004 <i>Replaces</i> 31675-005	White Autocar (Pre 1976)	0.53	1.88	21220-001	47086-004
		Mack	0.53	1.88	21220-003	47086-004
	CASTING NO. 47083-000 (LHF/RHR) (0.13 Offset) <i>Replaces</i> 31641-000 Undrilled Assy. 47355-003 <i>Replaces</i> 31675-013	Ford (L Series)	0.76	1.94	31643-001	47084-005
			CASTING NO. 47085-000 (RHF/LHR) (0.13 Offset) <i>Replaces</i> 31642-000 Undrilled Assy. 47355-004 <i>Replaces</i> 31675-014	Ford (L Series)	0.76	1.94
	CASTING NO. 44116-000 (LHF/RHR) Undrilled Assy. 47355-003 <i>Replaces</i> 31675-015			Peterbilt (Pre 1975)	0.66	2.00
		Peterbilt	0.66	2.25	◆ 44118-002	
	CASTING NO. 44117-000 (RHF/LHR) Undrilled Assy. 47355-004 <i>Replaces</i> 31675-016	Peterbilt (Pre 1975)	0.66	2.00	◆ 44119-001	
		Peterbilt	0.66	2.25	◆ 44119-002	

◆ **Obsolete**, contact Hendrickson Truck Parts for available options.



VEHICLES BUILT BEFORE 1983

FITS FRAME WIDTH OF 34.44" TO 34.69" (0.34" OFFSET)

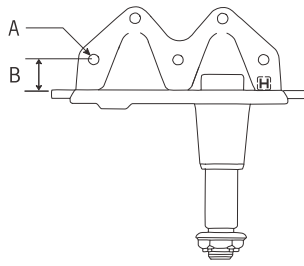

CASTING NO. **47087-000**
(LHF/RHR)
Replaces
09497-000

Undrilled Assy.
47355-005
Replaces
31675-003

OEM	DIMENSION A (IN INCHES)	DIMENSION B (IN INCHES)	PART NO.	REPLACEMENT PART NO.
American LaFrance	0.66	2.25	21117-016	47088-005
Brockway	0.59	1.88	21117-002	47088-004
Chrysler	0.59	1.88	21117-002	47088-004
Crane Carrier	0.66	2.25	21117-019	47088-002
Diamond Reo	0.59	1.88	21117-002	47088-004
Ford (C Series)	0.56	1.94	◆ 21862-002	
GMC (Pre 1976)	0.66	1.88	21117-003	47088-004
GMC	0.66	2.25	21117-021	47088-002
IHC	0.59	1.88	21117-012	47088-004
IHC*	0.66	2.25	21117-016	47088-005
Mack Western	0.66	2.25	21117-010	47088-002
Pem Fab	0.66	2.25	21117-010	47088-002
Spartan	0.66	2.25	21117-016	47088-005
White (Pre 1976)	0.59	1.88	21117-002	47088-004
White	0.66	2.25	21117-021	47088-002
White Autocar (Pre 1976)	0.66	1.88	21222-001	47088-004
White Autocar	0.66	2.25	21117-019	47088-002

*International (IHC) Usage thru 1988

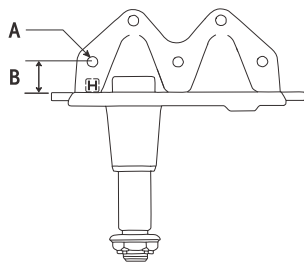

CASTING NO. **47089-000**
(RHF/LHR)
Replaces
09498-000

Undrilled Assy.
47355-006
Replaces
31675-004

American LaFrance	0.66	2.25	21118-016	47090-005
Brockway	0.59	1.88	21118-002	47090-004
Chrysler	0.59	1.88	21118-002	47090-004
Crane Carrier	0.66	2.25	21118-019	47090-002
Diamond Reo	0.59	1.88	21118-002	47090-004
Ford (C Series)	0.56	1.94	◆ 21863-002	
GMC (Pre 1976)	0.66	1.88	21118-003	47090-004
GMC	0.66	2.25	21118-021	47090-002
IHC	0.59	1.88	21118-012	47090-004
IHC*	0.66	2.25	21118-016	47090-005
Mack Western	0.66	2.25	21118-010	47090-002
Pem Fab	0.66	2.25	21118-010	47090-002
Spartan	0.66	2.25	21118-016	47090-005
White (Pre 1976)	0.59	1.88	21118-002	47090-004
White	0.66	2.25	21118-021	47090-002
White Autocar (Pre 1976)	0.66	1.88	21223-001	47090-004
White Autocar	0.66	2.25	21118-019	47090-002

*International (IHC) Usage thru 1988

FITS FRAME WIDTH OF 34.75" TO 35.00" (0.50" OFFSET)

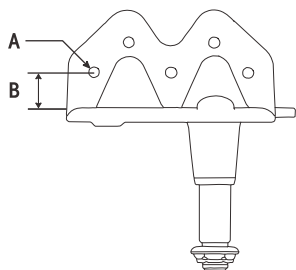

CASTING NO. **46759-000**
(LHF/RHR)
Replaced
34098-000
in 1980

Undrilled Assy.
47355-009

OEM	DIMENSION A (IN INCHES)	DIMENSION B (IN INCHES)	PART NO.	REPLACEMENT PART NO.
Ford	0.76	2.36	34100-001	48082-035
Spartan	0.76	2.36	34100-001	48082-035

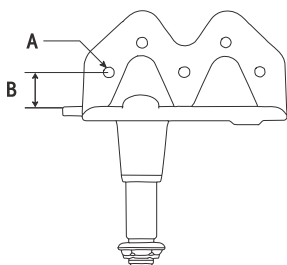

CASTING NO. **46758-000**
(RHF/LHR)
Replaced
34099-000
in 1980

Undrilled Assy.
47355-010

Ford	0.76	2.36	34101-001	48082-036
Spartan	0.76	2.36	34101-001	48082-036

◆ Obsolete, contact Hendrickson Truck Parts for available options.



HEAVY-DUTY FRAME HANGER

FITS FRAME WIDTH OF 33.50" (0.19" OFFSET)

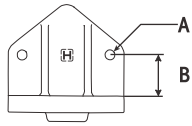

CASTING NO.
49117-000

OEM	DIMENSION A (IN INCHES)	DIMENSION B (IN INCHES)	PART NO.
Mack	0.66	2.12	49118-000

FITS FRAME WIDTH OF 33.94" TO 34.19" (0.09" OFFSET)

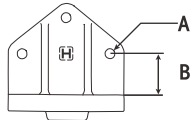

CASTING NO.
48522-000
Replaces
20780-000

Advance Mixer	0.66	1.88	48523-001
Crane Carrier	0.66	1.88	48523-001
Duplex Truck	0.66	1.88	48523-001
Ford	0.66	2.38	48523-005
Freightliner (Pre 1984)	0.66	1.88	48523-001
Freightliner	0.66	2.25	◆ 48523-003
HME	0.66	2.25	◆ 48523-003
Kenworth	0.66	2.25	48523-002
Mack	0.66	1.88	48523-001
Marmon	0.66	1.88	48523-001
International	0.66	1.88	48523-001
International	0.66	2.25	48523-002
Oshkosh	0.53	1.88	48523-006
Peterbilt	0.66	2.25	◆ 48523-003
Pierce Mfg.	0.66	2.25	48523-002
Savage Mfg.	0.66	2.25	48523-002
Western Star (Pre 1988)	0.66	1.88	48523-001
Western Star	0.66	2.25	48523-002

FITS FRAME WIDTH OF 33.44" TO 34.69" (0.34" OFFSET)

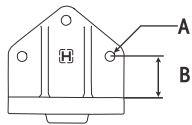

CASTING NO.
48524-000
Replaces
30088-000

Brockway	0.66	1.88	48525-002
Ford (C Series)	0.66	2.38	48525-004
Freightliner	0.66	2.25	48525-001
GMC	0.66	2.62	48525-005
Mack	0.66	2.25	48525-001
Peterbilt	0.66	2.25	48525-001

FITS FRAME WIDTH OF 34.75" TO 35.00" (0.50" OFFSET)

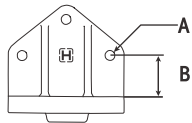

CASTING NO.
49119-000

Volvo GM	0.66	2.25	48525-001
Ford (Pre 1983)	0.66	2.25	49120-002
Ford	0.66	2.36	49120-001
Osterlund	0.66	2.25	49120-002
Spartan	0.66	2.25	49120-002

◆ **Obsolete**, contact Hendrickson Truck Parts for available options.

Components may vary by model, for part questions, contact Hendrickson Truck Parts toll-free at 866-755-5968 or email: truckparts@hendrickson-intl.com.

www.hendrickson-intl.com



Truck Suspension Systems 630.910.2800
800 South Frontage Road Fax 630.910.2899
Woodridge, IL 60517-4904 USA