

HR SERIES
Solid Mount

FOR MAXIMUM
DURABILITY
AND
STABILITY
IN SEVERE
APPLICATIONS.

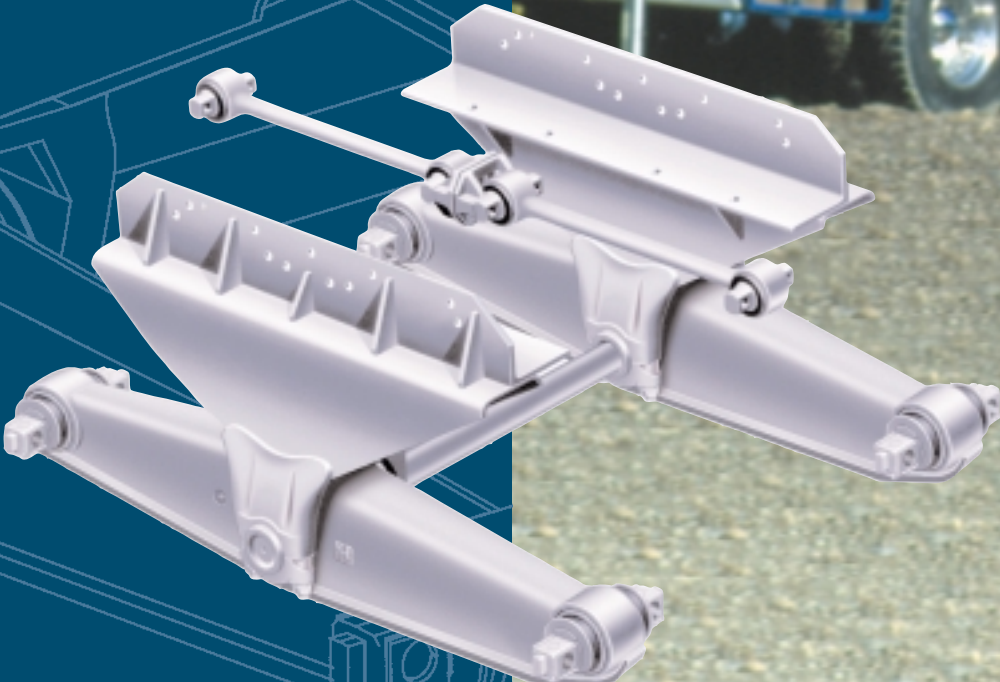

For The Road Ahead

HENDRICKSON

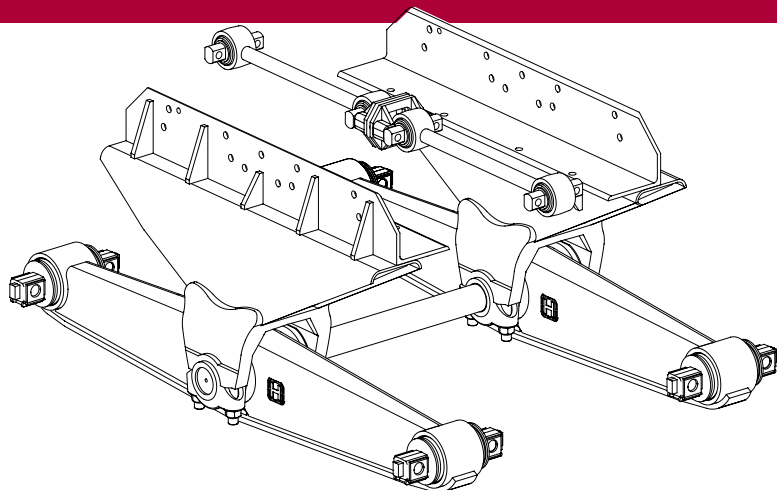

The R Series solid mount is an extra heavy-duty suspension excellent for severe service applications where maximum stability is essential.

SUSPENSION SPECIFICATIONS										
MODEL	BEAM TYPE ¹	INSTALLED WEIGHT ²	SUSPENSION RATING	GVW	GCW	WHEEL BASE RESTRICTIONS	SITE TRAVEL RATING ³	ARTICULATION	LIFT AXLES	AXLE SPACING
R 403	FAB BEAM	903 LBS.	40,000 LBS.	73,000	160,000	NONE	55,000 LBS.	15"	YES	52", 54", 56", 60", 72.5"
R 463	FAB BEAM	930 LBS.	46,000 LBS.	80,000	190,000	NONE	60,000 LBS.	15"	YES	52", 54", 56", 60", 72.5"
R 503	FORGED	1,047 LBS.	50,000 LBS.	80,000	225,000	NONE	65,000 LBS.	15"	YES	52", 54", 56", 60", 72.5"
R 523	FORGED	1,110 LBS.	52,000 LBS.	80,000	245,000	NONE	65,000 LBS.	15"	YES	52", 54", 56", 60", 72.5"

¹ Beam Type: Fabricated beam on 40,000 lbs. to 46,000 lbs. at 52", 54", 60", 72.5" axle spacing and 50,000 lbs. to 52,000 lbs. at 72.5" axle spacing. Cast beam on 40,000 lbs. to 52,000 lbs. at 56" axle spacing, 50,000 lbs. to 52,000 lbs. at 52" axle spacing, and forged beam at 54" and 60" axle spacing. Based on standard 54" axle spacing.

² Installed Weight: Includes complete suspension, torque rods, axle brackets, and frame brackets. Based on standard 54" axle spacing.

³ Site Travel Rating: Operators using vehicles equipped with liftable tag or pusher axles must not exceed published ratings. Ratings are limited to no more than 5% of vehicle operation at speed not to exceed 5 mph. Liftable tag or pusher axles should only be raised (or unloaded) to improve vehicle maneuverability in off-road use or when vehicle is unloaded. Site travel ratings are consistent with published axle manufacturer's limitations. Axle and suspension site travel ratings cannot be exceeded.

The R Series Delivers...

- **Great Durability and Reliability:** Fabricated beams (40,000-lb. to 46,000-lb. capacity) are robotically welded to create a strong, reliable box structure, with a superior strength-to-weight ratio. Heavy-duty bronze center bushing (46,000-lb. to 52,000-lb. capacities) delivers maximum durability.
- **Superior Stability Under All Conditions:** The walking beam design provides a high degree of traction on punishing job sites. Longitudinal rubber bushed torque rods prevent axle rotation during acceleration and braking. Transverse torque rods improve handling during cornering. (Recommended for refuse or severe service operations. Standard with axle spacings of 60" or more.) Solid mount saddle offers superior roll stability.
- **Extended Service Life/Reduced Maintenance:** Durable high confinement center bushing (40,000-lb. capacity) lasts longer, so fewer rebushings are needed over vehicle's life. Bar pin beam end connection also extends service life—and its axle alignment capability increases tire life.
- **More Sizes, Higher Capacities to Meet More Requirements:** R Series is available with 52", 54", 56", 58", 60", 64", and 72.5" equalizing beams; rated capacities range up to 120,000 lbs. For higher capacity, contact Hendrickson application engineering.
- **Designed for Heavy-duty Applications and Maximum Stability Requirements.**
- **Ideal for Lift Axle-Equipped Vehicles.**

HENDRICKSON
Truck Suspension Systems

A Boler Company