

TECHNICAL PROCEDURE

R™/RS™/RT™ Heavy-duty

SUBJECT: 650K/850K/1000K Pound Capacity Beam End Connection Tightening Torque Procedure

LIT NO: 17730-149

DATE: July 2006

REVISION: C

INTRODUCTION

This publication for the R™/RS™-650/850/1000, RT™-650 suspensions, equipped with two/three piece adapter type or tube and nut type beam end connections, is intended to acquaint and assist maintenance personnel in the proper tightening torque procedure of the mounting hardware. This procedure must be performed to ensure that the proper clamp force of the axle bracket legs against the end bushing's inner metal is obtained to achieve the maximum service life from the suspension system and mounting hardware. To obtain maximum service life from the suspension system, mounting bolts and nuts should be checked at least once a year and tightened to specified torque.

Two/three piece adapter type and **tube and nut type** beam end connection requires that the fasteners are tightened and maintained to a torque value within the specified torque range, see chart on page 3.

A simple torque wrench will not be sufficient to obtain the proper torque requirement. The proper torque requirement can be obtained with the use of a torque multiplier. If one is not available the use of a slug wrench is recommended.

CAUTION

A TECHNICIAN USING A SERVICE PROCEDURE OR TOOL WHICH HAS NOT BEEN RECOMMENDED BY HENDRICKSON MUST FIRST SATISFY HIMSELF THAT NEITHER HIS SAFETY NOR THE VEHICLE'S SAFETY WILL BE JEOPARDIZED BY THE METHOD OR TOOL SELECTED. INDIVIDUALS DEVIATING IN ANY MANNER FROM THE INSTRUCTIONS PROVIDED WILL ASSUME ALL RISKS OF CONSEQUENTIAL PERSONAL INJURY OR DAMAGE TO EQUIPMENT INVOLVED.

CAUTION

WEAR PROPER EYE PROTECTION TO HELP AVOID SERIOUS PERSONAL INJURY.

TORQUE PROCEDURE

Prior to removing the equalizing beam assembly from chassis, ensure the vehicle is properly supported with frame stands and the front wheels are chocked. Place a jack under each beam end, as shown in Figure 1, to check for movement of the rubber end bushing inner metal. This movement cannot be eliminated by tightening the fasteners due to excessive wear to mating parts and increasing clearance tolerances. If movement is noted, do not operate the vehicle. Replace the rubber end bushing and all connecting parts.

Figure 1

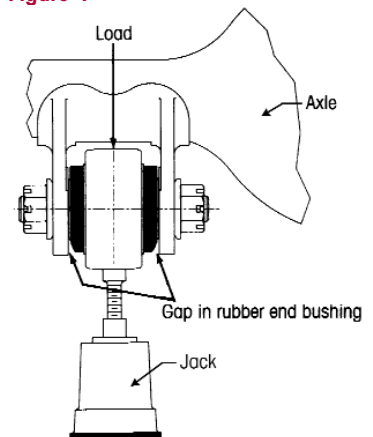
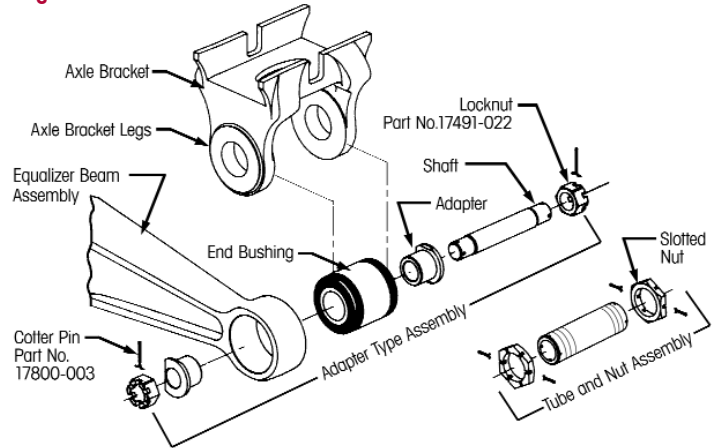

Figure 2



ASSEMBLY

1. Position equalizer beam assembly in the axle bracket on the axle.
2. Apply an anti-seize compound to all mating metal surfaces of the axle brackets, end bushings, and mounting hardware. This will aid in the assembly as well as prevent possible corrosion making future disassembly difficult.
3. Insert adapter or tube beam end connections, see Figure 2. For specific part numbers, see chart on back page.
4. For adapter type connection, rotate the adapters so the adapter cut off flats are vertical as shown in Figure 3.

NOTE

Axles must be in operational position before fasteners are tightened to prevent pre-loading of the rubber bushing.

Figure 3

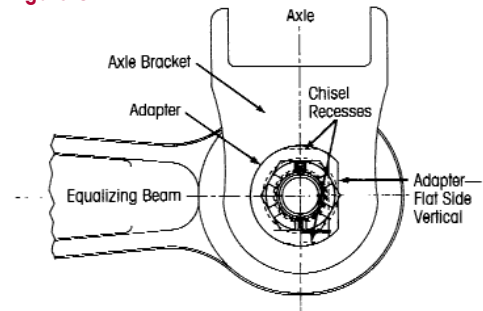

5. Assemble one slotted nut to the shaft and install the cotter pin. Place a suitable wrench on the nut and ensure the wrench is locked in place (braced) to prevent movement. Tighten using one of the following methods.

METHOD A: Torque Multiplier

- a. Assemble the opposite nut and using a torque wrench with multiplier, tighten the nut to Torque Multiplier value shown in Tightening Torque Specification chart on page 3.

CAUTION

DO NOT BACK OFF NUT TO INSTALL COTTER PIN, DOING SO MAY REDUCE THE TIGHTENING TORQUE BELOW THE REQUIRED SPECIFICATION.

- b. Install cotter pin. If cotter pin holes do not line up, the nut can be welded to the shaft to prevent movement of the nut.

Figure 4

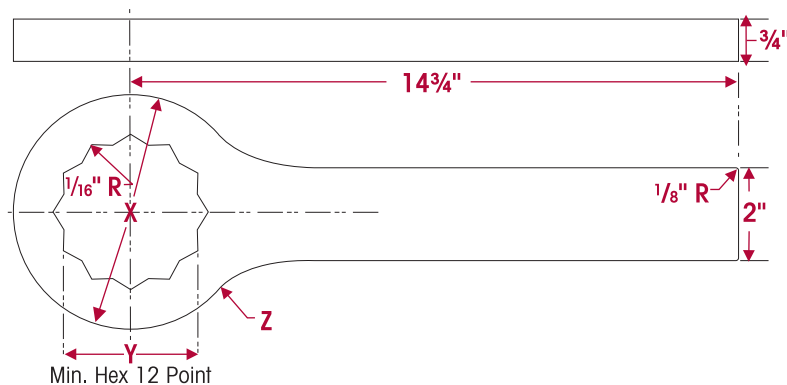

SLUG WRENCH SPECIFICATIONS		
	Adapter Type	Tube and Nut Type
X	5" DIA.	6 3/8" DIA.
Y	2 13/16"	4"
Z	2 1/2"	1 1/2"

METHOD B: Slug Wrench

To use slug wrenches, you will need:

- Two slug wrenches (see Figure 4 and matrix)
- 4 pound hammer

- a. Assemble the opposite nut and using a torque wrench, tighten the nut to the Initial Torque value shown in the Tightening Torque Specification chart below.
- b. Remove torque wrench and replace with the Slug Wrench. Using a four pound hammer, tighten the assembly by hitting the slug wrench near the handle as shown in Figure 5 until the nut has been turned to the degrees specified the Tightening Torque Specification chart below.

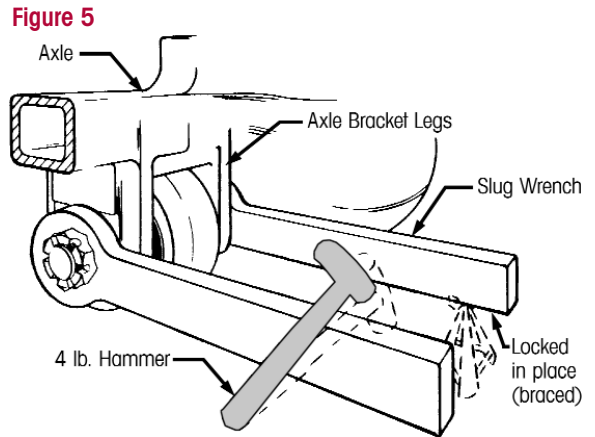

CAUTION

DO NOT BACK OFF NUT TO INSTALL COTTER PIN, DOING SO MAY REDUCE THE TIGHTENING TORQUE BELOW THE REQUIRED SPECIFICATION.

CAUTION

REPEATED HAMMERING BEYOND THE DEGREE SPECIFIED CAN CAUSE COMPONENT DAMAGE.

TIGHTENING TORQUE SPECIFICATIONS			
MODEL	SLUG WRENCH METHOD		TORQUE MULTIPLIER
Tube and Nut Connection			
	Initial torque	Plus	
R/RS/RT 650	200 ft. lbs.	 120 DEGREES 1/3 or 120° turn on slotted nut	1,100-1,300 ft. lbs.
Two and Three Piece Adapter Type Connection			
R/RS/RT 650	125 ft. lbs.	 90 DEGREES 1/4 or 90° turn on castle nut	600-800 ft. lbs.
R/RS 850	100 ft. lbs.	 180 DEGREES 1/2 or 180° turn on castle nut	2,000-2,500 ft. lbs.
R/RS 1000	125 ft. lbs.	 180 DEGREES 1/2 or 180° turn on castle nut	2,600-3,000 ft. lbs.



WARNING

INSUFFICIENT TIGHTENING TORQUES CAN CAUSE PREMATURE WEAR AND DAMAGE TO THE AXLE BRACKET LEGS, HOLES AND/OR BEAM END CONNECTION COMPONENTS, THIS CAN FURTHER CAUSE FAILURE AND SEPARATION OF COMPONENTS, AND RESULT IN LOSS OF VEHICLE CONTROL, SEVERE PERSONAL INJURY OR DEATH. MAINTAIN PROPER TIGHTENING TORQUES AT ALL TIMES.

BEAM END CONNECTION ASSEMBLY

	Two-piece Adapter Type			Three-piece Adapter Type			Tube and Nut Type	
Description	R/RS/RT 650	R/RS 850	R/RS 1000	R/RS/RT 650	R/RS 850	R/RS 1000	R/RS/RT 650	R/RS 1000
Beam End Assembly	21140-007* 21140-052	21140-004	21140-005	21140-027	21140-026	21140-024	21140-006	21140-042
Nut 1 7/8"-12 UNF 2B	17491-022			17491-022			10371-000	45457-000
Cotter Pin	17800-003			17800-003			17800-003	
Shaft	21592-003	21592-001	21592-002	21592-003	21592-001	21592-002		46558-000
Adapter	22057-000	21593-000	21594-000	45676-000	45677-000	21594-000		
Adapter Tube				45586-000	45581-000	45425-000		
Tube							10372-000	46493-000
Thrust Washer	45456-000			45456-000				

NOTE: * Beam End Assembly No. 21140-007 does not require Thrust Washer.

www.hendrickson-intl.com



Truck Suspension Systems
800 South Frontage Road
Woodridge, IL 60517-4904 USA

630.910.2800
Fax 630.910.2899