

# PRIMAAX<sup>®</sup> EX

Volvo Trucks. Driving Success.<sup>®</sup>

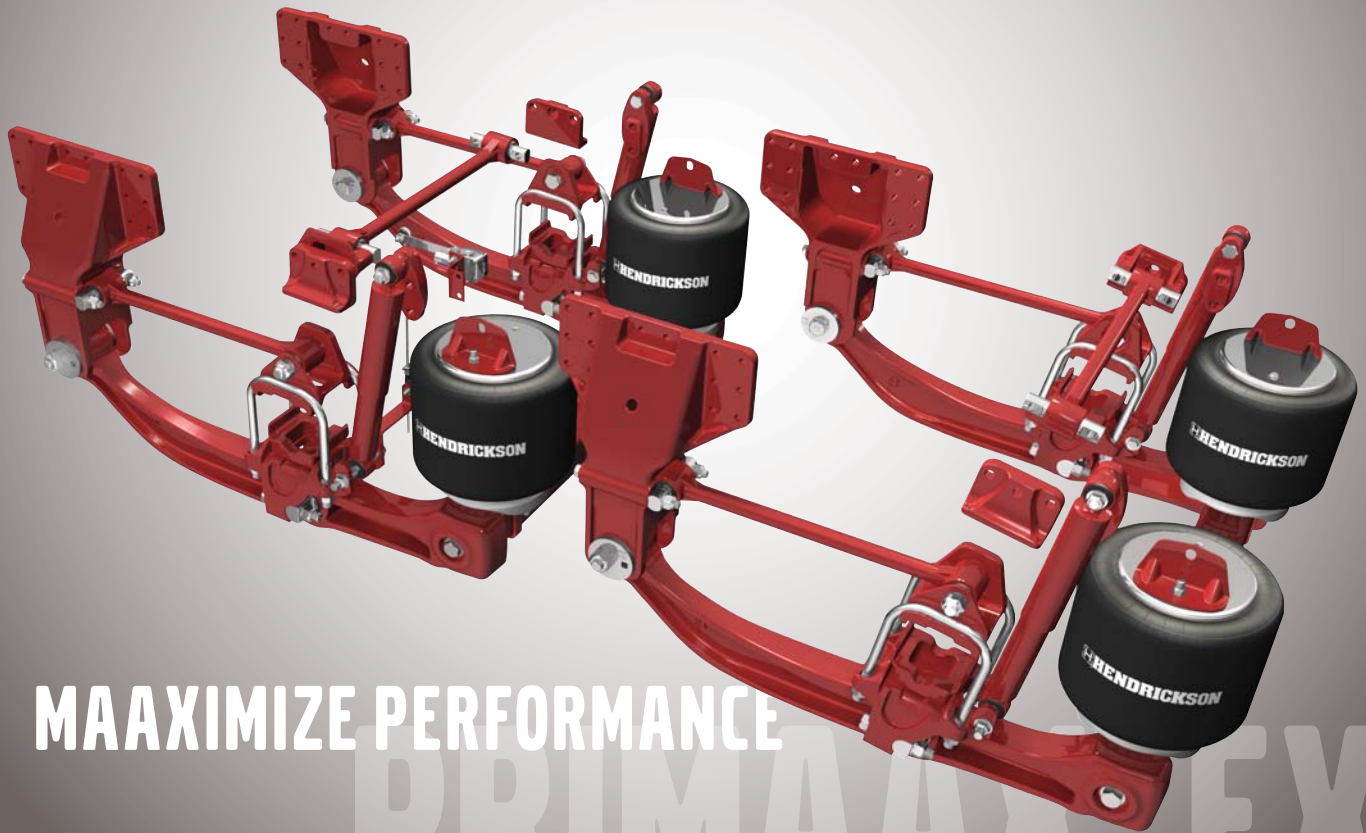

## MAXIMIZE PERFORMANCE

PRIMAAX<sup>®</sup> EX is a premium heavy-duty air suspension designed specifically for the rigorous demands of vocational, severe-service and heavy-haul applications. The system provides the same benefits as standard PRIMAAX with additional features designed to increase durability, reliability and handling characteristics.

- Superior Ride and Handling
- Optimized Torque Reactivity
- Increased Stability
- Reduced Maintenance
- Expanded Applications



## MAXIMIZE PERFORMANCE AND DURABILITY

### Genuine Hendrickson Torque Rods

- Optimized configuration helps improve handling and roll stiffness for expanded applications
- Premium retained rubber bushings for increased service life and resistance to walkout
- Alternative rods available for disc brake use

### Air Springs

- Large volume, low frequency design for improved ride
- Advanced design air springs lift and support the load with less air pressure

### Structural Beams

- Redesigned beams utilize premium materials to improve durability more than 350 percent\*
- Robust rubber bushings improve service life and eliminate lubrication requirements

### QUIK-ALIGN®

- Allows for easy axle alignment without shims
- Reduces maintenance time and helps extend tire life

### Heavy-duty Shock Absorbers

- Positioned and tuned for optimum damping characteristics

### Cross Beams

- Seamless fabrication technology forms a robust torsion system with structural beams, improving stability

### Axle Connections

- D-pin axle connection decreases torsional axle stress for reduced maintenance and increased joint integrity
- Integrated axle stop contact pads reduce axle stress

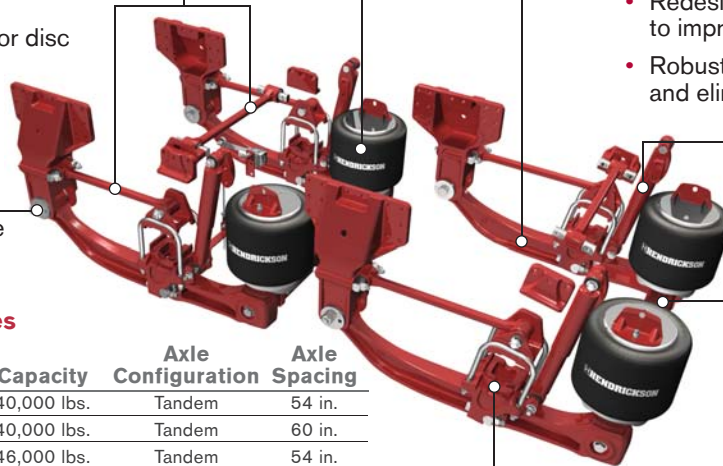

### PRIMAAX EX Sales Codes

Volvo Models	Sales Code	Capacity	Axle Configuration	Axle Spacing
VNL and VHD	350422	40,000 lbs.	Tandem	54 in.
	350423	40,000 lbs.	Tandem	60 in.
	350428	46,000 lbs.	Tandem	54 in.
	350429	46,000 lbs.	Tandem	60 in.
VNL300, VNL430 and VHD	350440	46,000 lbs.	Tridem	108 in.
	350441	48,000 lbs.	Tridem	108 in.
	350442	50,000 lbs.	Tridem	108 in.
	350443	52,000 lbs.	Tridem	108 in.
	350444	55,000 lbs.	Tridem	108 in.
	350445	58,000 lbs.	Tridem	108 in.
	350446	62,000 lbs.	Tridem	108 in.
	350447	65,000 lbs.	Tridem	108 in.
	350448	69,000 lbs.	Tridem	108 in.

\*Based on lab testing

45745-244 Rev A 09-09



Volvo Trucks North America  
P.O. Box 26115  
Greensboro, NC 27402-6115

www.volvotrucks.us.com  
1.800.444.RSVP

Volvo Trucks Canada  
5600A Cancross Court  
Mississauga, Ontario L5R 3E9

©2009 Volvo Group North America, Inc.  
PV835-PRIMAAX-EX

**VOLVO**