

H[®] TECHNICAL BULLETIN

STEERTEK AXLE FOR FREIGHTLINER, STERLING AND WESTERN STAR VEHICLES

SUBJECT: UPPER STEERING KNUCKLE

LIT NO: SEU-0215

DATE: July 2004

REVISION: A

IMPORTANT UPDATE

STEERTEK AXLE UPDATE

As of 6/28/2004, Freightliner, Sterling and Western Star will switch to $\frac{5}{8}$ " fine thread brake spider mounting hardware instead of the original $\frac{5}{8}$ " coarse thread hardware on all their vehicles equipped with the STEERTEK axle. Accordingly, Hendrickson Truck Suspension Systems is announcing a change to the STEERTEK axle upper steering knuckle to accommodate the fine thread brake spider mounting hardware intended for use on such Freightliner, Sterling and Western Star vehicles.

- The change will not affect any STEERTEK service procedures for vehicles built after 6/28/2004.
- Please note that all new replacement STEERTEK axles and upper steering knuckle components for Freightliner, Sterling and Western Star Vehicles will incorporate $\frac{5}{8}$ " fine threaded holes for brake spider mounting bolts. Vehicles built **prior to 6/28/2004** that are receiving a replacement of the STEERTEK axle or upper knuckle **will require** — a change from coarse thread brake spider mounting bolts to fine thread brake spider mounting bolts, see Figure 1. The brake spider mounting bolts are supplied separately by Freightliner, Sterling and Western Star, refer to vehicle manufacturer for bolt dimensions and torque specifications.

An upper steering knuckle parts matrix on the back side of this publication will assist in determining the correct hardware your vehicle requires.

Figure 1 New Left Hand Upper Steering Knuckle

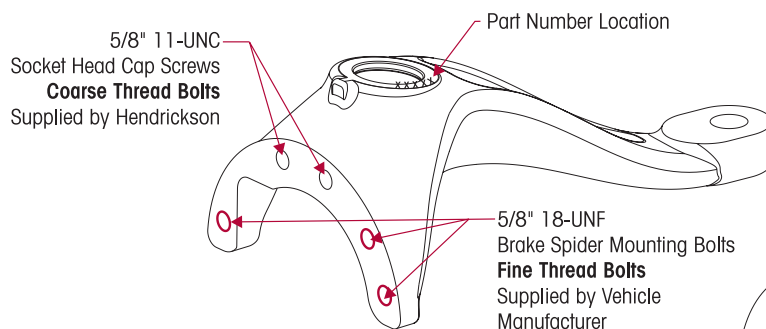

New Right Hand Upper Steering Knuckle

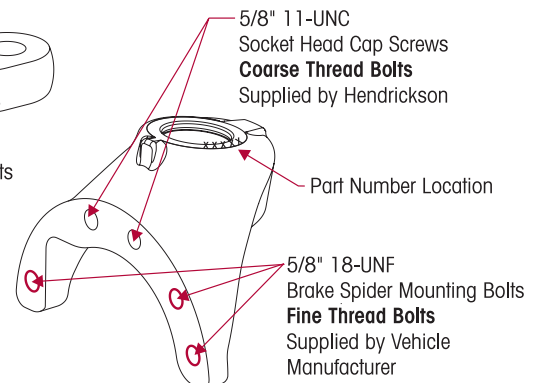

CONTINUED

IMPORTANT NOTE

Hendrickson will not be responsible for any damage to the STEERTEK upper knuckle components resulting from using improper brake spider mounting bolts.

Please contact Hendrickson Tech Services at 630.910.2800 or send email to techservices@hendrickson-intl.com with any questions on vehicles equipped with a STEERTEK axle.

Left Hand Upper Steering Knuckle	
Past Number (Coarse Thread Brake Spider Mounting Bolts)	New Number (Fine Thread Brake Spider Mounting Bolts)
60903-001	60903-031
60903-002	60903-032
60903-003	60903-033
60903-004	60903-034
60903-005	60903-035
60903-006	60903-036
60903-008	60903-038
60903-009	60903-039
60903-017	60903-047
60903-018	60903-048
Right Hand Upper Steering Knuckle	
60904-001	60904-031
60904-002	60904-032



Information contained in this literature was accurate at the time of publication. Product changes may have been made after the copyright date that are not reflected.

www.hendrickson-intl.com