

OUTSTANDING RIDE AND HANDLING

NEW EXTENDED WARRANTY



Designed for Volvo Trucks

AIRTEK® — the industry's first integrated front fabricated axle and air suspension system

With best-in-class ride and handling, AIRTEK comforts drivers, helps to protect cargo and reduces vibration-induced wear-and-tear on vehicles. Air springs support a majority of the load to provide a low spring rate and improve ride up to 30 percent versus a traditional two-leaf spring suspension.

AIRTEK's advanced technology incorporates Hendrickson's lightweight STEERTEK axle, the most advanced steer axle in the industry. Road proven with more than 90,000 units in operation since its introduction in 2001, AIRTEK trims up to 31 pounds compared to a traditional two-leaf spring with an I-beam axle.*

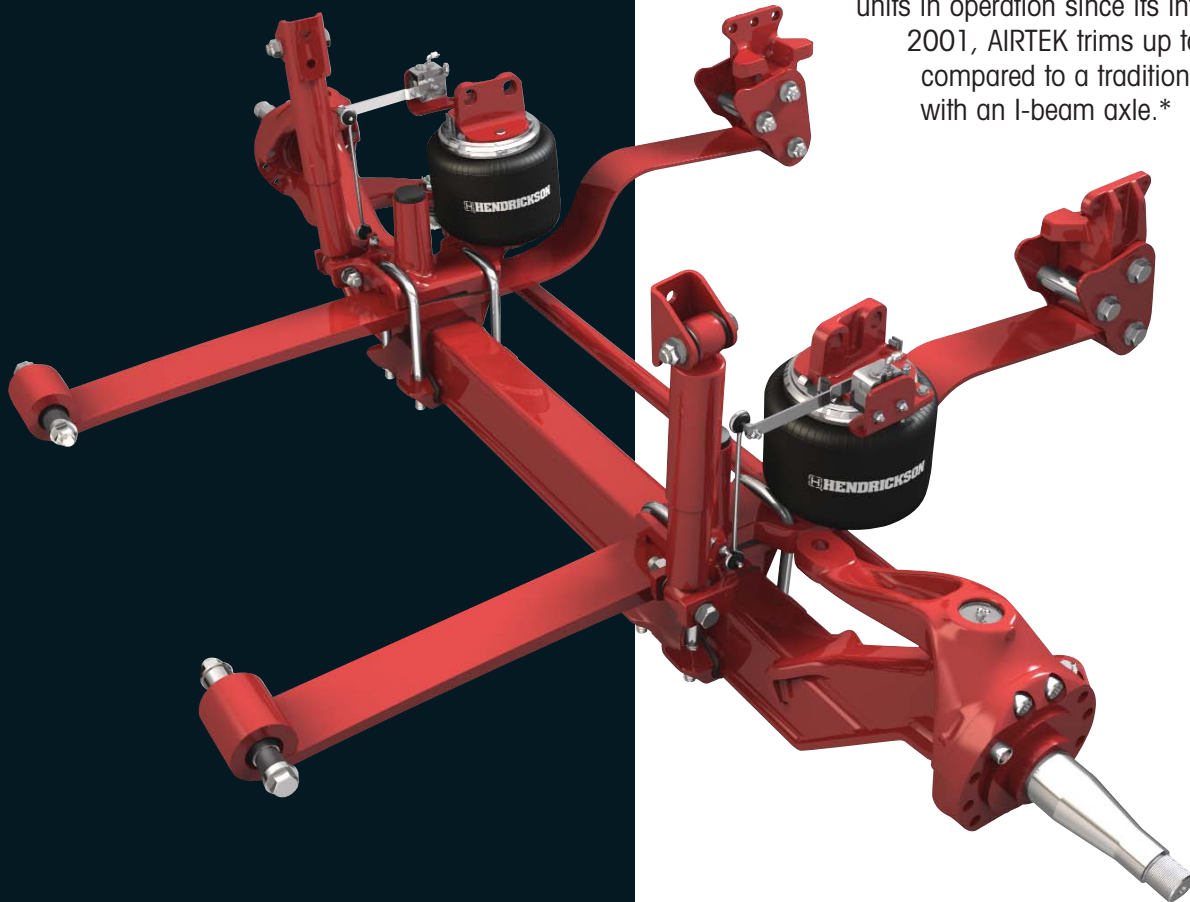

For additional information, call **630.910.2800** or visit the Hendrickson website at www.hendrickson-intl.com.

* Weight savings is based on Volvo's data book list

For The Road Ahead™



Specify AIRTEK® for superior ride and handling

Improved Air Spring Support

for enhanced ride and extended air spring life.

Dual Height Control Valves

for optimal vehicle balance, overall driver comfort and enhanced feel.

Improved Tie Rod Design

for extended tie rod life and reduced system maintenance.

Serviceable Air Spring Fittings

to improve the serviceability of the air springs and help reduce maintenance costs.

STEERTEK Axle

with a box-shaped cross section resists horizontal, vertical and twisting forces more effectively than a traditional I-beam axle.

Two-piece Knuckle

trims weight and delivers up to 50 degrees of wheel cut.

Optimized Shock Tuning

to assure a premium ride for drivers and their cargo.

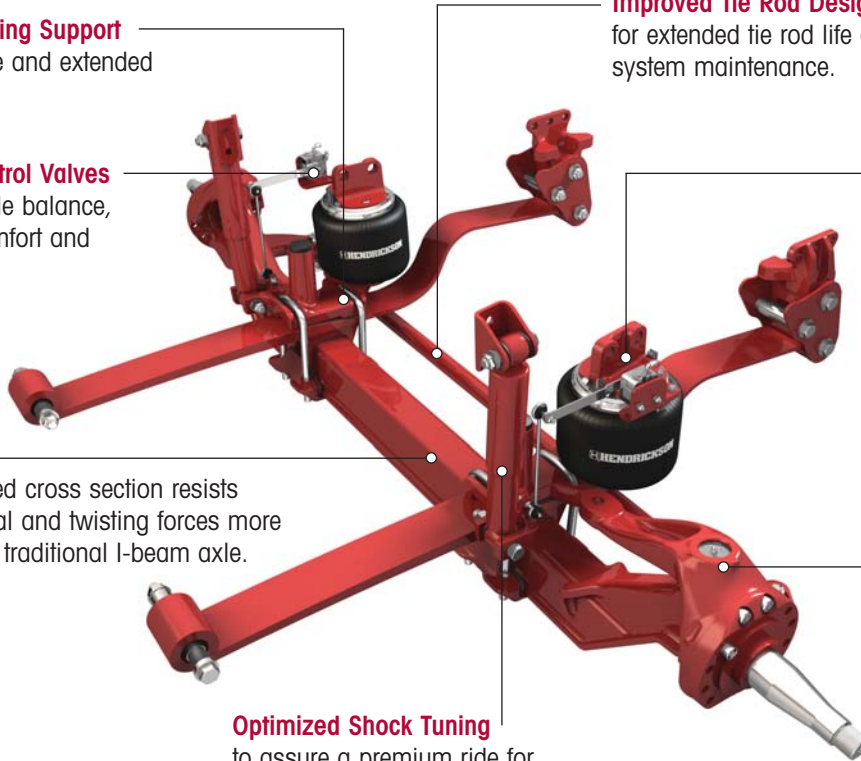

Sales Codes

Capacity	Hubs	Drop	AIRTEK Sales Codes	STEERTEK Sales Codes
12,000	Basic Front Hubs	Deep	371-076	370-374
	Unitized Front Hubs	Deep		370-378
	Basic Front Hubs	Standard		370-351
	Unitized Front Hubs	Standard		370-355
12,500	Basic Front Hubs	Deep		370-375
	Unitized Front Hubs	Deep		370-379
	Basic Front Hubs	Standard		370-352
	Unitized Front Hubs	Standard		370-356
13,200	Basic Front Hubs	Deep		370-376
	Unitized Front Hubs	Deep		370-380
	Basic Front Hubs	Standard		370-353
	Unitized Front Hubs	Standard		370-357
14,600	Basic Front Hubs	Deep	370-377	
	Basic Front Hubs	Standard	370-354	

Extended Warranty

- Five years / 750,000 miles on structural components
 - ✓ Axle beam and kingpin
 - ✓ Steering arms
 - ✓ Knuckle
 - ✓ Spindles
 - Two years / 200,000 miles on air springs▲
 - One year / 100,000 miles on remaining Hendrickson supplied components
- ▲ Systems built after July 18, 2007

Actual product performance may vary depending upon vehicle configuration, operation, service and other factors.

www.hendrickson-intl.com



Truck Suspension Systems
800 South Frontage Road
Woodridge, IL 60517-4904 USA

630.910.2800
Fax 630.910.2899