

INTRAAX® SP

AAZNT 23K/46K /69K
AAZL 23K/46K SPECIFICATIONS

LIT NO: L840

DATE: February 2024

REVISION: F

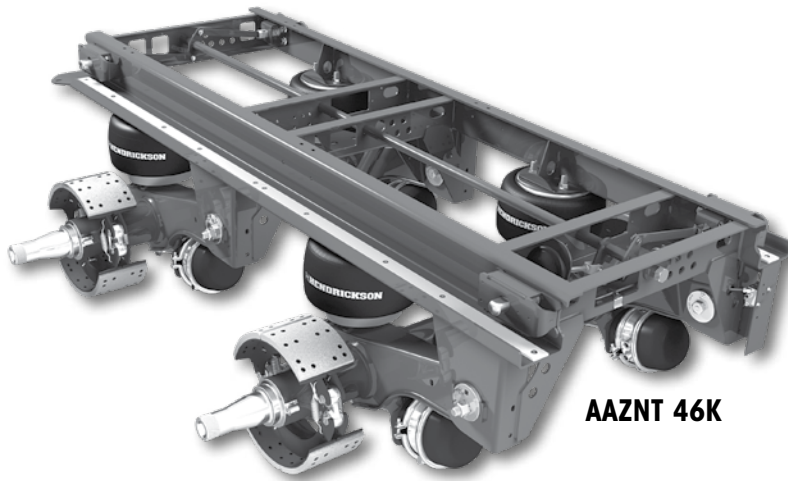
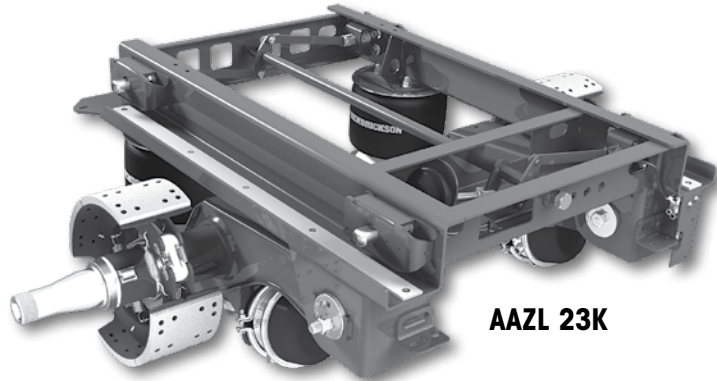
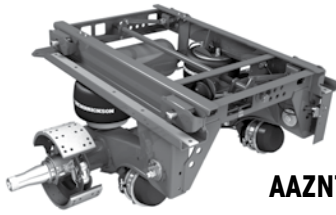

TABLE OF CONTENTS

SPECIFICATIONS

AAZNT 23K / AAZNT 46K.....	2-3
AAZNT 69K.....	4-5
AAZL 23K / AAZL 46K.....	6-7
OPTIONS.....	8



AAZNT 23K

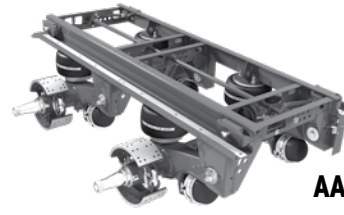

AAZNT 46K

*SYSTEM CAPACITY:	23,000 lbs. (10 400 kg)	46,000 lbs. (20 700 kg)
APPLICATION:	On-highway	On-highway
TRAILER TYPES:	UNITED STATES AND CANADA Platform MEXICO, CENTRAL AND SOUTH AMERICA None	UNITED STATES AND CANADA Platform MEXICO, CENTRAL AND SOUTH AMERICA None
FRAME TYPES:	Trailer width: 96 or 102 inch I-beam centers: 37, 38, 43 or 44 inch Bottom flange width: 4, 4.5 or 5 inch	Trailer width: 96 or 102 inch I-beam centers: 37, 38, 43 or 44 inch Bottom flange width: 4, 4.5 or 5 inch
AXLE DATA:	Arrangement: Single Spacing: N/A Diameter: 5.75 inch LDA™ Large-Diameter Axle Track: 71.5 and 77.5 inch	Arrangement: Tandem Spacing: 49-, 60- and 72-inch spreads Diameter: 5.75 inch LDA Large-Diameter Axle Track: 71.5 and 77.5 inch
BASE MODEL DESCRIPTION:	AAZNT platform slider suspension system consisting of Z-rail slider box designed for 37-inch I-beam centers with 14-inch ride height INTRAAX® suspension(s), 71.5-inch axle track, HN spindles, standard shock absorbers, 16.5 × 7-inch brakes with H20 brake lining, ABS brackets and QUIK-ALIGN®. QUIK-DRAW® pneumatic pin-pull mechanism and Cam Tube System™ standard.	

* System capacity refers to the suspension, axle and slider. Ratings for brakes and wheel-end components differ depending upon options chosen.

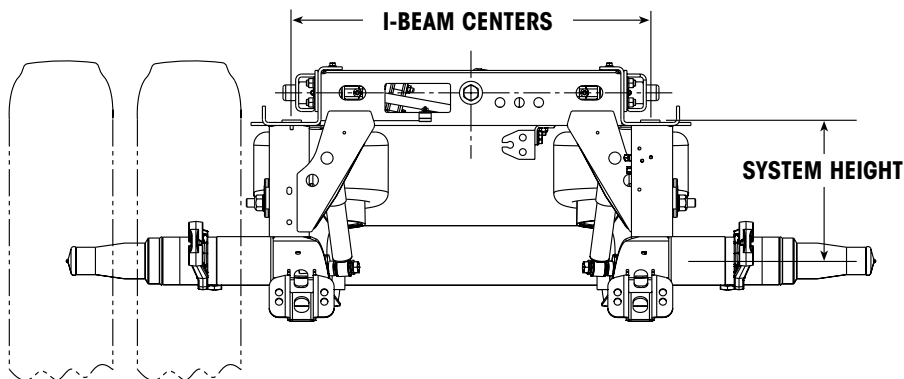



AAZNT 23K					
RIDE HEIGHT (inches)	SYSTEM HEIGHT (inches)	FRONT AXLE LOCATION (inches)	JOUNCE (inches)	REBOUND (inches)	WEIGHT* (pounds)
13.5	14	26.5	3.3	5.4	758
14	14.5	26.4	3.8	4.9	758
15	15.5	26	3.8	3.9	759
16	16.5	26.4	3.8	4.7	768
17	17.5	26	3.9	3.7	774

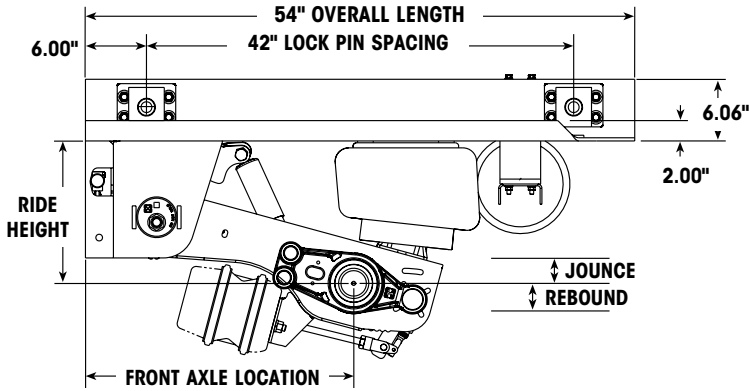

*Weights reflect base model specifications. For 38-inch I-beam centers, add 2 pounds. For 43-inch I-beam centers, add 20 pounds. For 44-inch I-beam centers, add 22 pounds.

AAZNT 46K							
RIDE HEIGHT (inches)	SYSTEM HEIGHT (inches)	FRONT AXLE LOCATION (inches)	JOUNCE (inches)	REBOUND (inches)	WEIGHT* (pounds)		
					49" Spread	60" Spread	72" Spread
13.5	14	26.5	3.3	5.4	1,428	1,462	1,495
14	14.5	26.4	3.8	4.9	1,428	1,462	1,495
15	15.5	26	3.8	3.9	1,431	1,464	1,498
16	16.5	26.4	3.8	4.7	1,448	1,482	1,515
17	17.5	26	3.9	3.7	1,459	1,493	1,527

AXLE SPACING (inches)	OVERALL LENGTH (inches)	LOCK PIN SPACING (inches)
49	102	90
60	114	102
72	126	114

*Weights reflect base model specifications. For 38-inch I-beam centers, add 3.84 pounds. For 43-inch I-beam centers, add 37 pounds. For 44-inch I-beam centers, add 41 pounds.

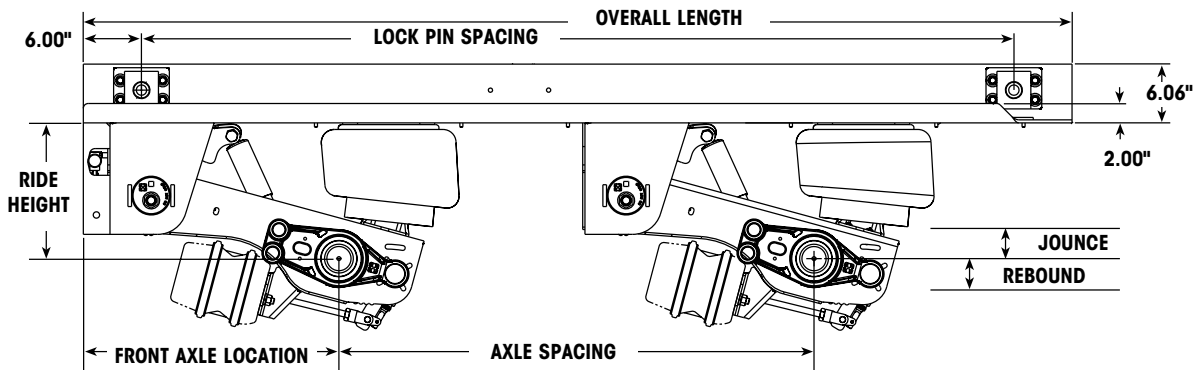



AAZNT 69K

*SYSTEM CAPACITY:	69,000 lbs. (10,400 kg)
APPLICATION:	On-highway
TRAILER TYPES:	UNITED STATES AND CANADA Platform MEXICO, CENTRAL AND SOUTH AMERICA None
FRAME TYPES:	Trailer width: 96 or 102 inch I-beam centers: 37, 38, 43 or 44 inch Bottom flange width: 4, 4.5 or 5 inch
AXLE DATA:	Arrangement: Tridem Spacing: 60 or 72 inch Diameter: 5.75 inch LDA™ Large-Diameter Axle Track: 71.5 and 77.5 inch
BASE MODEL DESCRIPTION:	AAZNT platform slider suspension system consisting of Z-rail slider box designed for 37-inch I-beam centers with 14-inch ride height INTRAAX® suspension(s), 71.5-inch axle track, HN spindles, standard shock absorbers, 16.5 × 7-inch brakes with H2O brake lining, ABS brackets and QUIK-ALIGN®. QUIK-DRAW® pneumatic pin-pull mechanism and Cam Tube System™ standard.

* System capacity refers to the suspension, axle and slider. Ratings for brakes and wheel-end components differ depending upon options chosen.

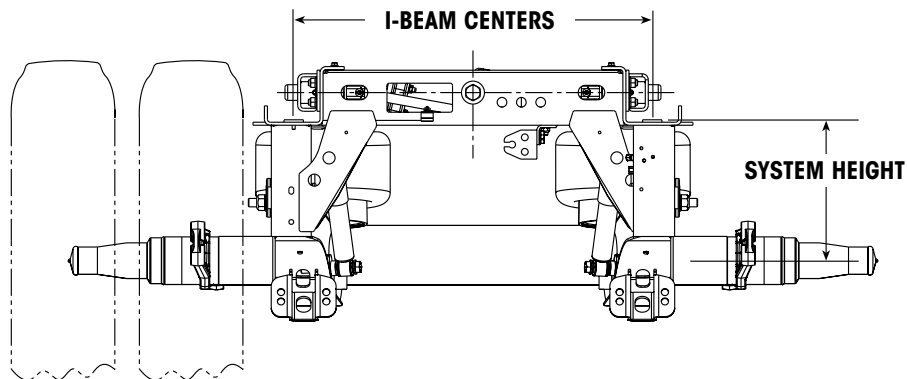



AAZNT 69K						
RIDE HEIGHT (inches)	SYSTEM HEIGHT (inches)	FRONT AXLE LOCATION (inches)	JOUNCE (inches)	REBOUND (inches)	WEIGHT* (pounds)	
					60" Spread	72" Spread
13.5	14	26.5	3.3	5.4	1,462	1,495
14	14.5	26.4	3.8	4.9	1,462	1,495
15	15.5	26	3.8	3.9	1,464	1,498
16	16.5	26.4	3.8	4.7	1,482	1,515
17	17.5	26	3.9	3.7	1,493	1,527

*Weights reflect base model specifications. For 38-inch, 43-inch or 44-inch I-beam centers, refer to AAZNT 69K23 installation drawing (D-32782).

AXLE SPACING (inches)	OVERALL LENGTH (inches)	LOCK PIN SPACING (inches)
60	174	162
72	198	186

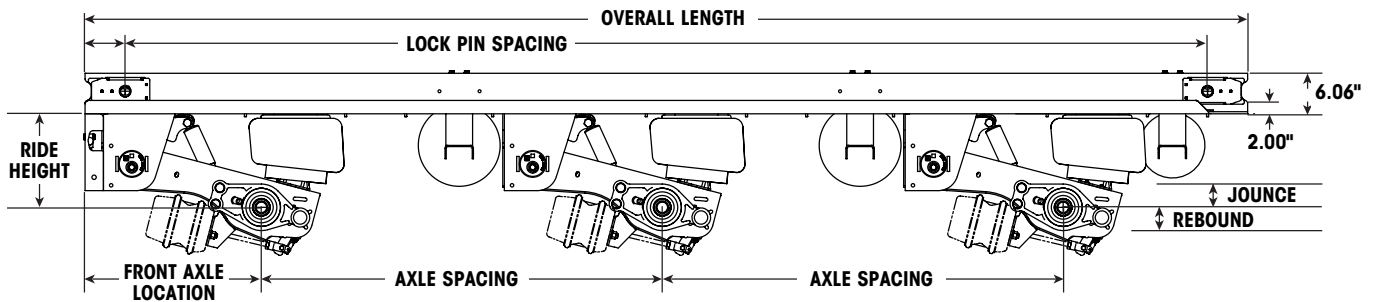



AAZL 23K

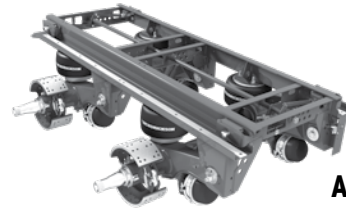

AAZL 46K

*SYSTEM CAPACITY:	23,000 lbs. (10 400 kg)	46,000 lbs. (20 700 kg)
APPLICATION:	On-highway	On-highway
TRAILER TYPES:	UNITED STATES AND CANADA Platform, Drop Deck MEXICO, CENTRAL AND SOUTH AMERICA None	UNITED STATES AND CANADA Platform, Drop Deck MEXICO, CENTRAL AND SOUTH AMERICA None
FRAME TYPES:	Trailer width: 96 or 102 inch I-beam centers: 37, 38, 43 or 44 inch Bottom flange width: 4, 4.5 or 5 inch	Trailer width: 96 or 102 inch I-beam centers: 37, 38, 43 or 44 inch Bottom flange width: 4, 4.5 or 5 inch
AXLE DATA:	Arrangement: Single Spacing: N/A Diameter: 5.75 inch LDA™ Large-Diameter Axle Track: 71.5 and 77.5 inch	Arrangement: Tandem Spacing: 49-, 60- and 72-inch spreads Diameter: 5.75 inch LDA Large-Diameter Axle Track: 71.5 and 77.5 inch
BASE MODEL DESCRIPTION:	AAZL platform slider suspension system consisting of Z-rail slider box designed for 37-inch I-beam centers with 6.5-inch ride height INTRAAX® suspension(s), 71.5-inch axle track, HN spindles, standard shock absorbers, 16.5 x 7-inch brakes with H2O brake lining, ABS brackets and QUIK-ALIGN®. QUIK-DRAW® pneumatic pin-pull mechanism and Cam Tube System™ standard.	

* System capacity refers to the suspension, axle and slider. Ratings for brakes and wheel-end components differ depending upon options chosen.

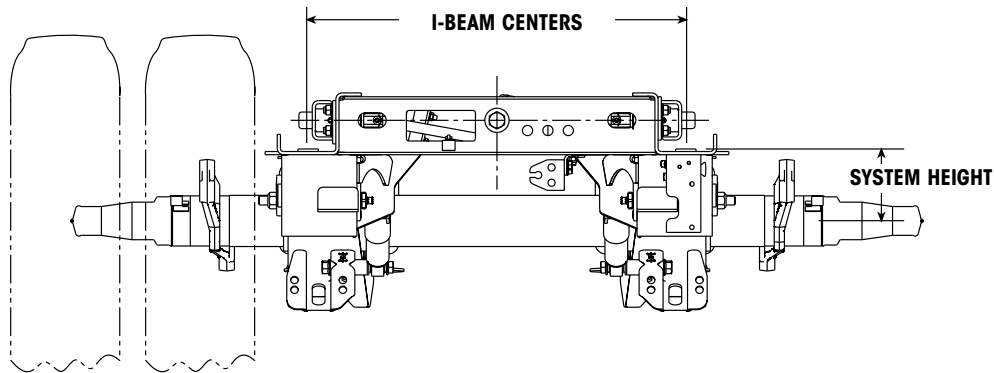



AAZL 23K					
RIDE HEIGHT (inches)	SYSTEM HEIGHT (inches)	FRONT AXLE LOCATION (inches)	JOUNCE (inches)	REBOUND (inches)	WEIGHT* (pounds)
6.5	7	26.4	2.3	4.5	845
7.5	8	26.4	3.3	3.5	845
8	8.5	26.2	3.8	5.2	845
9	9.5	26	4.8	4.2	845
12	12.5	26.1	5.3	4.8	862

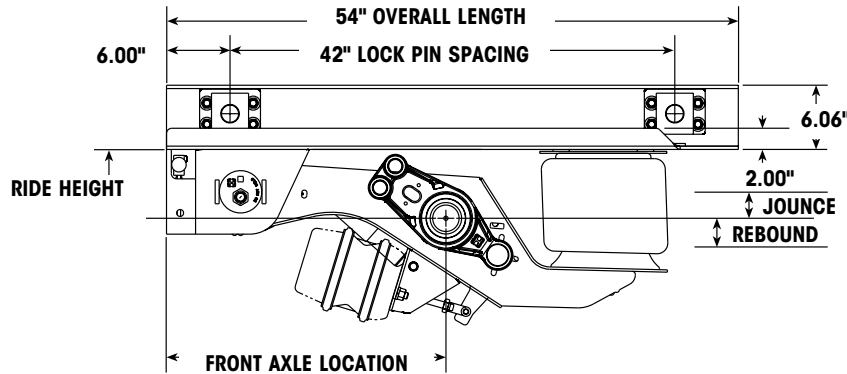

*Weights reflect base model specifications. For 38-inch I-beam centers, add 2 pounds. For 43-inch I-beam centers, add 20 pounds. For 44-inch I-beam centers, add 22 pounds.

AAZL 46K							
RIDE HEIGHT (inches)	SYSTEM HEIGHT (inches)	FRONT AXLE LOCATION (inches)	JOUNCE (inches)	REBOUND (inches)	WEIGHT* (pounds)		
					49" Spread	60" Spread	72" Spread
6.5	7	26.4	2.3	4.5	1,601	1,637	1,671
7.5	8	26.4	3.3	3.5	1,601	1,637	1,671
8	8.5	26.2	3.8	5.2	1,601	1,637	1,671
9	9.5	26	4.8	4.2	1,601	1,637	1,671
12	12.5	26.1	5.3	4.8	1,635	1,671	1,704

AXLE SPACING (inches)	OVERALL LENGTH (inches)	LOCK PIN SPACING (inches)
49	102	90
60	114	102
72	126	114

*Weights reflect base model specifications. For 38-inch I-beam centers, add 3.84 pounds. For 43-inch I-beam centers, add 37 pounds. For 44-inch I-beam centers, add 41 pounds.

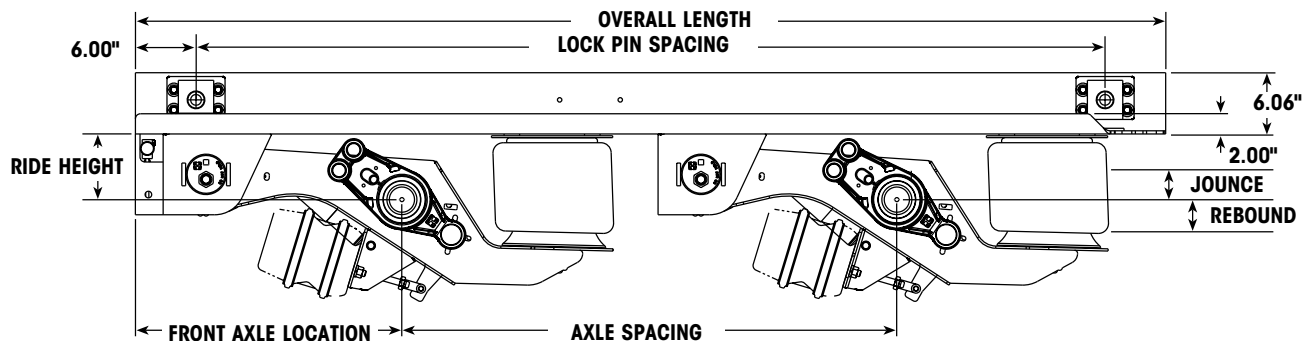



BEARINGS

SPINDLE TYPE	TUBE O.D. (inches)	BEARINGS			
		INNER CONE	OUTER CONE	INNER CUP	OUTER CUP
HN	5.75	HM218248	HM212049	HM218210	HM212011
HP	5.75	HM518445	HM518445	HM518410	HM518410

HENDRICKSON MAXX22T™

Hendrickson trailer air disc brake system specifically designed to optimize performance for North American trailer applications, with WABCO brake technology, features premium offerings including the lightweight Dura-Light Hub® option, TIREMAAX®, and RTR® READY-TO-ROLL® wheel-end packages.

RTR® READY-TO-ROLL®

Choose from a broad mix of offerings to customize running gear for specific applications. Wheel-end options consist of aluminum, ductile iron or Dura-Light Hub® in a variety of standard and extended service wheel-end packages. The Outboard Mounted Rotor is an available option for units that specify HXL7® Extended-Life 7-Year System™ with MAXX22T air disc brakes. Refer to L1239 MAXX22T Flyer for more information.

BRAKE OPTIONS

For complete details of the wide range of brake options available including lining choices, brake ratings FMVSS / CMVSS 121 brake certifications, refer to publication *L809 Brake Certifications*.

BRAKE CHAMBERS

Industry standard brake chambers with pushrod length of 9.75 inches and clamping / port orientation of zero degrees are compatible with all top-mount (AAZNT) models. A pushrod length of 5.63 inches and clamping / port orientation of zero degrees is required for the low-ride (AAZL) models.

BRAKE ADJUSTERS

Industry standard 5.5- and 6-inch brake adjusters are compatible.

BOLT-ON AIR TANK BRACKET KITS

For use with industry standard jumbo or small tanks.

SINGLE-AXLE SLIDER REPOSITIONING KIT

Recommended for all single-axle sliders used in conjunction with fixed suspensions. The kit locks the brakes and dumps the air on the sliding axle for ease of repositioning.

HEIGHT CONTROL VALVE KITS

Standard height control valve (HCV) kits, as well as HCV kits with auto dump valves, are available for use with the AAZ sliders on straight platform trailers. A special HCV kit with a raise feature is recommended when using an AAZL slider with a fixed suspension on a drop-deck trailer with wheelhouses. The kit locks the brakes, dumps the air on the sliding axle(s) and raises the trailer deck by adding air to the fixed suspension. The AAZL slider can then be moved to its new location by repositioning the trailer. Refer to *L1182 Trailer Controls Catalog* for specific HCV part numbers.

STINGER

Bolt-on bracket available in 24-inch length.

MUD FLAP MOUNTING ANGLE

Bolt-on bracket attaches to rear cross member.

LOAD SCALE KITS

Provide accurate axle loading readings; available in both dry and liquid-filled gauge models.



NOTES:

A series of 25 horizontal lines for writing notes.

*Actual product performance may vary depending upon vehicle configuration, operation, service and other factors.
All applications must comply with applicable Hendrickson specifications and must be approved by the respective vehicle manufacturer with the vehicle in its original, as-built configuration.
Contact Hendrickson for additional details regarding specifications, applications, capacities, and operation, service and maintenance instructions.*

Call Hendrickson at 866.RIDEAIR (743.3247) for additional information.



www.hendrickson-intl.com

TRAILER COMMERCIAL VEHICLE SYSTEMS

2070 Industrial Place SE
Canton, OH 44707-2641 USA
866.RIDEAIR (743.3247)
Fax 800.696.4416

Hendrickson Canada ULC

2825 Argentic Road, Unit #2 - 4
Mississauga, ON Canada L5N 8G6
800.668.5360
905.789.1030 • Fax 905.812.9423

Hendrickson Mexicana

Circuito El Marqués Sur #29
Parque Industrial El Marqués
Pob. El Colorado, Municipio El Marqués,
Querétaro, México C.P. 76246
+52 (442) 296.3600 • Fax +52 (442) 296.3601

L840 Rev F 02-24

© 2003 – 2024 Hendrickson USA, L.L.C. All Rights Reserved. All trademarks shown are owned by Hendrickson USA, L.L.C., or one of its affiliates, in one or more countries.
Information contained in this literature was accurate at the time of publication. Product changes may have been made after the copyright date that are not reflected.

Printed in United States of America