

H ASSEMBLY INSTRUCTIONS

ULTRA ROD® PLUS™

SUBJECT: ULTRA ROD PLUS Bushing Installation
with Funnel Tool 66086-000

LIT NO: 59310-028

DATE: February 2006

REVISION: A



INTRODUCTION

ULTRA ROD® PLUS™ TORQUE ROD BUSHING NOS.

64400-002L
64400-003L
64400-004L
64400-005L
64400-006L
64400-007L
64400-008L
64400-009L
64400-010L

Rebushing a Hendrickson ULTRA ROD® PLUS™ torque rod with the new “bonded bushing” is now easier with the use of a new funnel tool. To order funnel tool Part No. 66086-000 Contact your local truck dealer or authorized Hendrickson distributor. It helps prevent damage to the torque rod bushing during installation. Below you will find easy to use step-by-step instructions

DISASSEMBLY

You will need:

- A vertical press with a capacity of at least 10 tons.
- Torque rod bushing receiving tool (see Figure 1)
- Torque rod bushing assembly tool (funnel) Part No. 66086-000 (see Figure 2)

FIGURE 1
TORQUE ROD BUSHING
RECEIVING TOOL

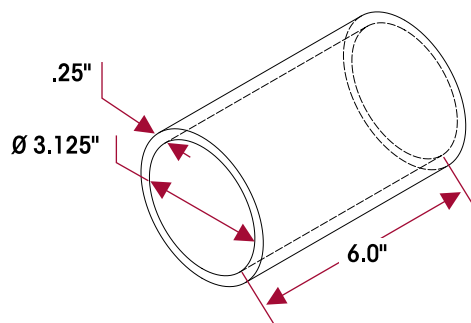
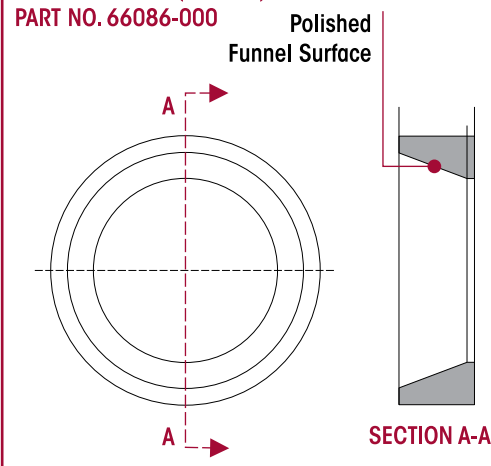

FIGURE 2
TORQUE ROD BUSHING
ASSEMBLY TOOL (FUNNEL)
PART NO. 66086-000



WARNING

DO NOT USE HEAT OR USE A CUTTING TORCH TO REMOVE THE BUSHINGS FROM THE TORQUE ROD. THE USE OF HEAT WILL ADVERSELY AFFECT THE STRENGTH OF THE TORQUE ROD. HEAT CAN CHANGE THE MATERIAL PROPERTIES. A COMPONENT DAMAGED IN THIS MANNER CAN RESULT IN THE LOSS OF VEHICLE CONTROL AND POSSIBLE PERSONAL INJURY OR PROPERTY DAMAGE.

WARNING

ALWAYS WEAR PROPER EYE PROTECTION AND OTHER REQUIRED PERSONAL PROTECTIVE EQUIPMENT TO HELP PREVENT PERSONAL INJURY WHEN YOU PERFORM VEHICLE MAINTENANCE, REPAIR OR SERVICE.

1. Remove the torque rod assembly per vehicle manufacturer's instructions.



2. Prior to disassembly of the torque rod bushing, mark the clocking position of the torque rod bushing bar pin flats on the torque rod end hub with a paint stick.
3. Install the torque rod in the press. Support the torque rod end hub on the receiving tool with the end hub of the torque rod centered on the receiving tool. Be sure the torque rod is squarely supported on the press bed.
4. Push directly on the bar pin until the bushing clears the torque rod end hub.

FIGURE 3



INSPECTION AND CLEANING

1. Inspect the torque rod for straightness, wear, or cracks. Replace as necessary.
2. Clean and inspect the inner diameter of the torque rod end hubs. Break any sharp edges and remove any nicks with an emery cloth or a rotary sander, see Figure 3.

FIGURE 4



ASSEMBLY

1. Lubricate the inner diameter of the torque rod end hub, the assembly funnel, and the new rubber bushing with P-80® or vegetable base oil (cooking oil), see Figure 4.

DO NOT USE A PETROLEUM OR SOAP BASE LUBRICANT. SUCH LUBRICANTS CAN CAUSE ADVERSE REACTIONS WITH THE BUSHING, SUCH AS DETERIORATION OF THE RUBBER, CAUSING PREMATURE FAILURE.

2. Support the torque rod end hub on the receiving tool with the end hub of the torque rod centered on the receiving tool.
3. Place the assembly funnel centered on the torque rod end hub.
4. Place the torque rod bushing centered in the assembly funnel, see Figure 5. The bar pin must have the mounting flats positioned as prior to disassembly.

CAUTION



5. Press the bar pin through the assembly funnel into torque rod end hub until the rubber clears the assembly funnel, see Figure 6.

FIGURE 5



FIGURE 6



6. When pressing in the new bushings overshoot the desired final position by approximately $\frac{3}{16}$ " , see Figure 7.
7. Remove the assembly funnel.
8. Press the bar pin again from the opposite side to center the bar pin within the torque rod end hub, see Figure 8. The rubber bushing and the bar pin must be centered within the torque rod end hubs.

FIGURE 7



FIGURE 8



9. Wipe off any excess lubricant. Allow the lubricant a minimum of four hours to dissipate before operating the vehicle.

CAUTION

IF THE TORQUE ROD ASSEMBLY IS NOT ALLOWED THE ALLOTTED TIME FOR THE LUBRICANT TO DISSIPATE, THE BUSHING WILL SLIDE FROM THE TORQUE ROD END HUB. IF THIS OCCURS, THE BUSHING MAY BE DAMAGED AND THE BUSHING WILL THEN NEED TO BE REMOVED AND A NEW BUSHING REINSTALLED.

10. Install torque rod assembly per vehicle manufacturer's instructions.

Actual product performance may vary depending upon vehicle configuration, operation, service and other factors.
All applications must comply with applicable Hendrickson specifications and must be approved by the respective vehicle manufacturer with the vehicle in its original, as-built configuration.
Contact Hendrickson for additional details regarding specifications, applications, capacities, and operation, service and maintenance instructions.

*Call Hendrickson at **1.866.755.5968** (toll-free) or **1.630.910.2800** for additional information.*



www.hendrickson-intl.com

TRUCK COMMERCIAL VEHICLE SYSTEMS

800 South Frontage Road
Woodridge, IL 60517-4904 USA
1.866.755.5968 (Toll-free U.S. and Canada)
1.630.910.2800 (Outside U.S. and Canada)
Fax 1.630.910.2899

59310-028 Rev A 02-06

© 2006 Hendrickson USA, L.L.C. All Rights Reserved. All trademarks shown are owned by Hendrickson USA, L.L.C., or one of the affiliates, in one or more countries.
Information contained in this literature was accurate at the time of publication. Product changes may have been made after the copyright date that are not reflected.

Printed in United States of America