

# **H** TECHNICAL PROCEDURE

## TRI-FUNCTIONAL<sup>®</sup> BUSHINGS

**SUBJECT:** Replacement Bushing Tube Spacer  
Orientation

**LIT NO:** L893

**DATE:** March 2015

**REVISION:** B

When installing the replacement bushing tube spacers in this kit, make sure the recessed side of each spacer faces the bushing tube as shown in figure 1.

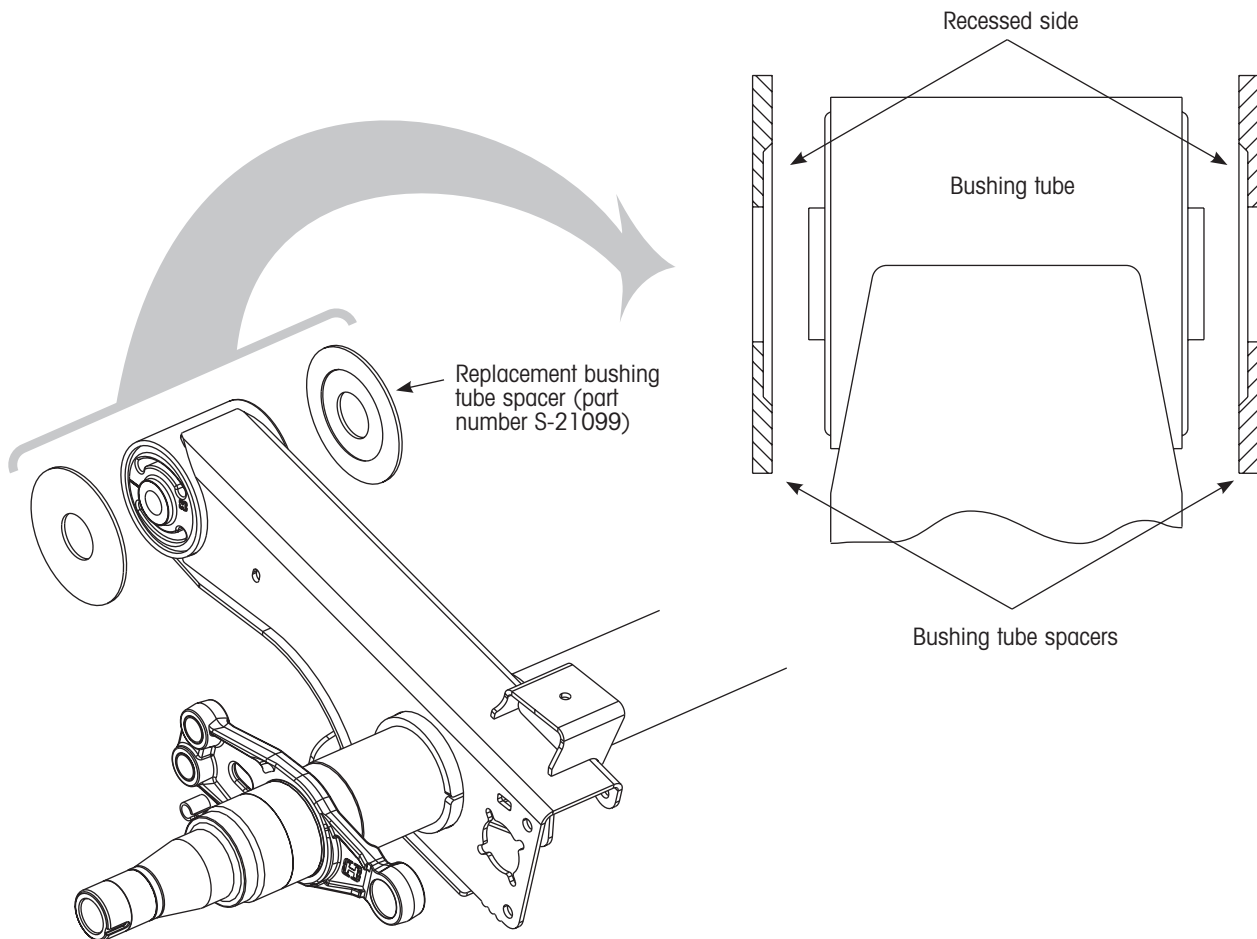

Figure 1. Properly orienting the replacement bushing tube spacer for installation

Hendrickson introduced the new, longer lasting replacement bushing tube spacer (BTS) for use in all wide bushing, TRI-FUNCTIONAL® II (TFII), applications.

Available only as an aftermarket part, the replacement BTS (part number S-21099) provides increased protection for suspensions that have experienced some in-service wear of the pivot connection components. The replacement BTS is thicker than previously-available aftermarket bushing tube spacers, which will increase its service life. The replacement BTS also features a machined recess that allows the bushing to flex, elongate and otherwise absorb forces generated by accelerating, braking and irregular road surfaces without adding stress to the pivot connection or causing harm to the bushing.

Available individually or in a kit, the replacement BTS supercedes both previously-available spacers: the flat spacer, part number S-11613, and the cap-style spacer (see illustration below). The replacement BTS is also being included in all bushing service kits, such as S-6914 and S-24691.

Because of the increased thickness of the replacement BTS, all BTS service kits will only contain two

S-21099 spacers instead of the three S-11613 spacers previously included.

These refinements serve as another example of our commitment to continuous improvement and innovation to help enhance the serviceability, value and lifespan of your vehicles.

Refer to Hendrickson publication L750, TRI-FUNCTIONAL® Bushing Tube Spacer Inspection / Replacement Procedure, available at <http://www.hendrickson-intl.com/L750>, for complete bushing tube spacer inspection, evaluation and repair procedures.

Suspensions using the narrow, TRI-FUNCTIONAL III (TFIII) bushing will not be affected by this change.

Please contact Hendrickson Trailer Technical Services for the United States and Canada at 866-RIDEAIR (743-3247) or in Mexico at +52 (442) 296-3600 for further information.

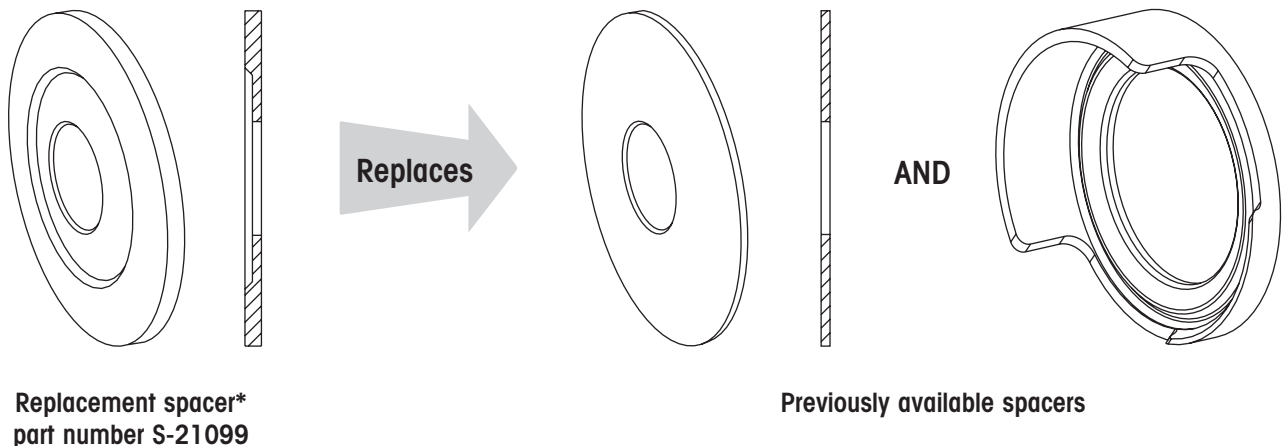

\*Note: Machined recess on S-21099 spacer must face towards the exposed surface of the bushing.

Call your trailer dealer or Hendrickson at **330.489.0045** or **866.RIDEAIR (743.3247)** for additional information.



[www.hendrickson-intl.com](http://www.hendrickson-intl.com)

**TRAILER COMMERCIAL VEHICLE SYSTEMS**

2070 Industrial Place SE  
Canton, OH 44707-2641 USA  
866.RIDEAIR (743.3247)  
330.489.0045 • Fax 800.696.4416

**Hendrickson Canada**

250 Chrysler Drive, Unit #3  
Brampton, ON Canada L6S 6B6  
800.668.5360  
905.789.1030 • Fax 905.789.1033

**Hendrickson Mexicana**

Circuito El Marqués Sur #29  
Parque Industrial El Marqués  
Pob. El Colorado, Municipio El Marqués,  
Querétaro, México C.P. 76246  
+52 (442) 296.3600 • Fax +52 (442) 296.3601