



VANTRAAX[®]

Ramp Ready HKARL 46K Integrated Air Slider System

- Enhanced weight savings and strength
- Easy to retrofit
- Extends trailer life



Enhanced weight savings and strength

Put all the advantages of lightweight and tough sliding suspension technology to work for fleets that require ramp service with the VANTRAAX[®] Ramp Ready integrated slider system. This configuration addresses fleets' needs for lighter, more durable running gear. Eliminating heavy, expensive spacer tubes, this ramp ready slider delivers all the competitive advantages fleets need.

Easy to retrofit

The patented VANTRAAX Ramp Ready model accepts ramps that install in a 30-inch wide and 6.5-inch tall space. This 46,000-pound capacity slider system easily installs on applicable trailers using standard industry body rails with four- or six-inch pin spacing. Ramps are available separately from trailer manufacturers. Retrofitting trailers is as simple as changing out sliders and installing a ramp.

Extends trailer life

In addition to minimizing cargo damage, VANTRAAX's superior smooth ride helps protect trailer structure, hardware and electronics; to extend trailer life and offers another tool to attract and retain drivers. The VANTRAAX Ramp Ready delivers the same high quality and proven durability that fleet managers and owner operators expect from Hendrickson.



To learn more about VANTRAAX Ramp Ready, call 866.743.3247 or visit www.hendrickson-intl.com

HENDRICKSON
The World Rides On Us[®]

VANTRAAX® HKARL 46K System Features and Benefits

TRI-FUNCTIONAL® Bushing

- Controls vertical, horizontal and roll forces of trailer
- Optimizes ride softness, control and stability

Patented[▲] K-2® Slider Box

- Helps prevent racking
- Increases strength and slider life

QUIK-ALIGN® Pivot Connection

- Fast and easy axle alignment
- Requires no welding or special tools

QUIK-DRAW® Fully Pneumatic Pin-Pull Mechanism

- Automatic reset engages pins when parking brake releases
- Driver-friendly finger tip operation
- Helps reduce driver strain and enhance productivity

Neutral-Toe Axle

- Helps increase fuel economy and tire life
- Straight tracking

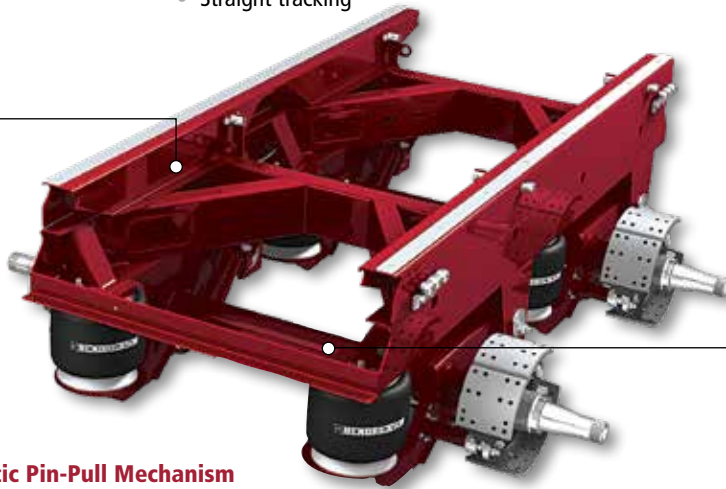

Patented[▲] Trailer Cam Tube System™

- Enhances S-cam alignment and helps extend life of brake components
- Short 10-inch S-cam reduces windup and bushing wear for responsive, consistent stopping power

Advanced Axle Wrap and Window Weld

- Provides optimal structural integrity

LDA™ Large-Diameter Axle

- Trims weight compared to five-inch axle, allowing more cargo per load
- Bending and torsional stiffness increased for rugged durability
- Greater roll stability
- Reduced deflection under load

▲ This product is covered by at least one or more U.S. and/or foreign patents and/or pending U.S. and/or foreign patent applications. See Hendrickson for details.

Value-Added Options

- RTR® READY-TO-ROLL® wheel-end options reduce weight, enhance durability and lower maintenance
- TIREMAAX® tire inflation system helps maximize tire life and maintain peak fuel mileage
- HXS® Hendrickson Extended Service™ brakes extend intervals between brake service

See RTR READY-TO-ROLL Wheel-End Flyer - L1200
See TIREMAAX PRO Brochure - L1199

- UBL™ UNDER BEAM LIFT™ is a lightweight mechanism which offers cost savings and operational flexibility
- Air disc brakes available including Hendrickson MAXX22T™ optimized trailer air disc brake
- Cambered axle option for grain and livestock trailers available

See UBL UNDER BEAM LIFT Flyer - L727
See MAXX22T Flyer - L1239

Easy Installation or Retrofit

- Installs using standard body rails — eliminates spacer tubes
- Available in four- or six-inch pin spacing
- Simply change out sliders and add a ramp to retrofit a standard trailer

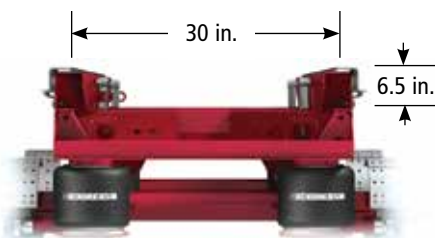

Ramp bay: 30 in. wide, 6.5 in. tall

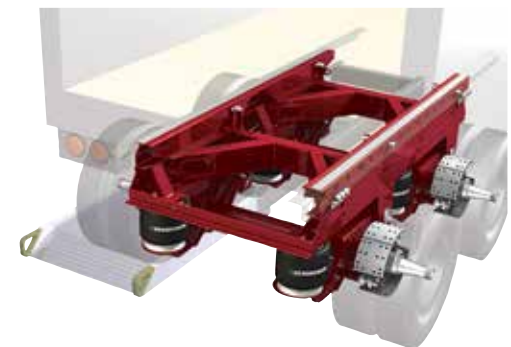

Actual product performance may vary depending upon vehicle configuration, operation, service and other factors.

All applications must comply with applicable Hendrickson specifications and must be approved by the respective vehicle manufacturer with the vehicle in its original, as-built configuration. Contact Hendrickson for additional details regarding specifications, applications, capacities, and operation, service and maintenance instructions.

Call Hendrickson at **330.489.0045** or **866.RIDEAIR (743.3247)** for additional information.



www.hendrickson-intl.com

TRAILER COMMERCIAL VEHICLE SYSTEMS
2070 Industrial Place SE
Canton, OH 44707-2641 USA
866.RIDEAIR (743.3247)
330.489.0045 • Fax 800.696.4416

Hendrickson Canada ULC
2825 Argenta Road, Unit #2 - 4
Mississauga, ON Canada L5N 8G6
800.668.5360
905.789.1030 • Fax 905.802.9423

Hendrickson Mexicana
Circuito El Marqués Sur #29
Parque Industrial El Marqués
Pob. El Colorado, Municipio El Marqués,
Querétaro, México C.P. 76246
+52 (442) 296.3600 • Fax +52 (442) 296.3601

L773 Rev E 03-22

© 2001 – 2022 Hendrickson USA, L.L.C. All Rights Reserved. All trademarks shown are owned by Hendrickson USA, L.L.C., or one of its affiliates, in one or more countries. Information contained in this literature was accurate at the time of publication. Product changes may have been made after the copyright date that are not reflected.

Printed in United States of America