



# TRLAXLE®

## Non-Integrated Trailer Axles

- Wide variety of suspension / axle configurations
- Versatility for the global market
- Low-maintenance



TRLAXLE Trailer Axle



TRLAXLE Trailer Axle  
Drop Center Option

### Axle that fits global needs

Hendrickson offers a full line of industry standard, low maintenance non-integrated trailer axles to fit a variety of configurations for the global, commercial and industrial vehicle markets. TRLAXLE® trailer axles are available in numerous spindle types, capacities and axle tracks, drum or air disc brakes, 12¼- to 16½-inch brakes and many RTR® READY-TO-ROLL® wheel-ends, slack adjuster and brake chamber options – to fit either air or mechanical spring applications.

By combining Hendrickson TRLAXLE trailer axles with HT™ Series air suspensions, Hendrickson offers a wide variety of suspension / axle combinations and application coverage. TRLAXLE trailer axles deliver a low cost, low maintenance solution and superior customer and warranty support.



To learn more about TRLAXLE,  
call 866.743.3247 or visit  
[www.hendrickson-intl.com](http://www.hendrickson-intl.com)

 **HENDRICKSON**  
*The World Rides On Us®*

# TRLAXLE® Trailer Axle Features and Benefits

## Axle

- Axle capacities from 20,000 to 27,000 pounds
- Available in 1/2- to 3/4-inch wall
- Patented<sup>▲</sup> axle filter protects the wheel-end from contamination
- Select 6-inch drop center options available

## Drum Brakes

- 12 1/4-, 15-, 16 1/2-inch brake shoe diameters in various widths

## Hendrickson Proprietary Brake Linings

- Available in standard service and HXS® Hendrickson Extended Service™ brake shoes

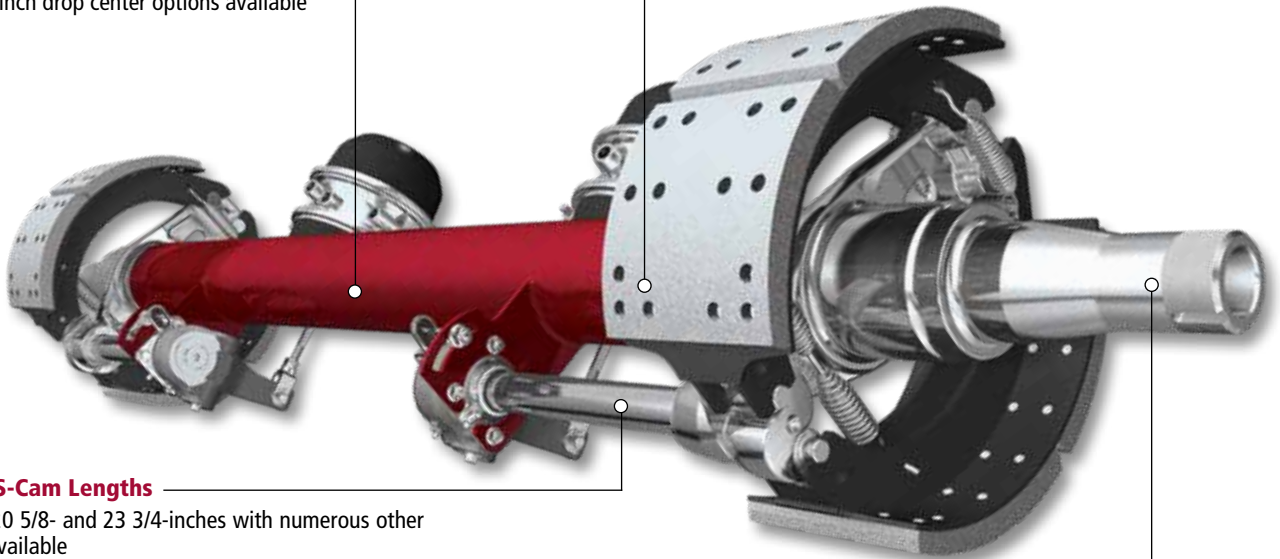

## Standard S-Cam Lengths

- 17 5/8-, 20 5/8- and 23 3/4-inches with numerous other lengths available

## Cam Tube (Cam Cover)

- Cam tube option to extend cam life
- Available for limited cam lengths: 11 1/8-, 17 5/8-, 20 5/8-, 22 5/8-, 23 3/4-, 24 1/4-, 25 1/2-, 26 1/2- and 28 3/8-inches

<sup>▲</sup>This product is covered by at least one or more U.S. and/or foreign patents and/or pending U.S. and/or foreign patent applications. See Hendrickson for details.

## HP and HN Spindles

- Friction-welded
- Parallel spindle promotes even lubrication of inner and outer bearings
- Approved for wide base tires using 2-inch offset rims (HP spindles ONLY)

## TRLAXLE Trailer Axle Value-Added Options

- RTR® READY-TO-ROLL® wheel-end options reduce weight, enhance durability and lower maintenance
  - HXL3® Hendrickson Extended-Life 3-year System™
  - HXL5® Hendrickson Extended-Life 5-year System™
  - HXL7® Hendrickson Extended-Life 7-year System™
- Ductile iron, Dura-Light Hub® or aluminum hubs
- Standard and heavy-duty drums
- TIREMAAX® tire inflation system helps maximize tire life and maintain peak fuel mileage<sup>†</sup>
- Air disc brakes available, including Hendrickson's MAXX22T™ optimized trailer air disc brake, with limited tracks and no 3/4-inch wall<sup>†</sup>

- 5.5- or 6-inch slack adjusters
- Brake chambers in various configurations
- Dust shields (15- and 16 1/2-inch brake size only) are optional on dressed axles only
- All Hendrickson TRLAXLE® trailer axles are backed by an industry leading limited warranty\* and Hendrickson's superior customer and technical support
- AAXTREME COAT® premium brake shoe coating provides extreme protection in tough environments

See RTR READY-TO-ROLL Wheel-End Flyer - Literature No. L1200

See TIREMAAXPRO Brochure - Literature No. L1199

See AAXTREME COAT Flyer - Literature No. L1207

See MAXX22T Flyer - Literature No. L1239

<sup>†</sup> Not available with drop axles or 1/2-inch wall axles

\* For complete warranty terms, conditions and limitations, see the current version of Hendrickson's Comprehensive Warranty Statement L583 (available at [www.hendrickson-intl.com](http://www.hendrickson-intl.com)).

Actual product performance may vary depending upon vehicle configuration, operation, service and other factors.

All applications must comply with applicable Hendrickson specifications and must be approved by the respective vehicle manufacturer with the vehicle in its original, as-built configuration. Contact Hendrickson for additional details regarding specifications, applications, capacities, and operation, service and maintenance instructions.

Call Hendrickson at 330.489.0045 or 866.RIDEAIR (743.3247) for additional information.



[www.hendrickson-intl.com](http://www.hendrickson-intl.com)

### TRAILER COMMERCIAL VEHICLE SYSTEMS

2070 Industrial Place SE  
Canton, OH 44707-2641 USA  
866.RIDEAIR (743.3247)  
330.489.0045 • Fax 800.696.4416

### Hendrickson Canada ULC

2825 Argenta Road, Unit #2 - 4  
Mississauga, ON Canada L5N 8G6  
800.668.5360  
905.789.1030 • Fax 905.802.9423

### Hendrickson Mexicana

Circuito El Marqués Sur #29  
Parque Industrial El Marqués  
Pob. El Colorado, Municipio El Marqués,  
Querétaro, México C.P. 76246  
+52 (442) 296.3600 • Fax +52 (442) 296.3601