

TECHNICAL PROCEDURE

TRAILER SUSPENSION SYSTEMS AKAD0012 LIFT AXLE VALVE

SUBJECT: Test Procedure

LIT NO: T52002

DATE: November 2016

This procedure applies to suspension systems equipped with Hendrickson's AKAD0012 lift valve and related plumbing. **Before performing these procedures** or otherwise operation of the valve, refer to Hendrickson literature number T12007 *Recommended Safety Precautions for Service and Repair Procedures* available at www.Hendrickson-intl.com/TrailerLit and all applicable service, maintenance and safety instructions issued by the trailer manufacturer, ABS controller manufacturer and any other applicable equipment manufacturers.

⚠ CAUTION: Movement of suspension parts may result in personal injury.

NOTE: Adhere to any federal, state, and/or local government and company safety practices.

To prevent the trailer from moving, **chock** the wheels of an axle not being raised.

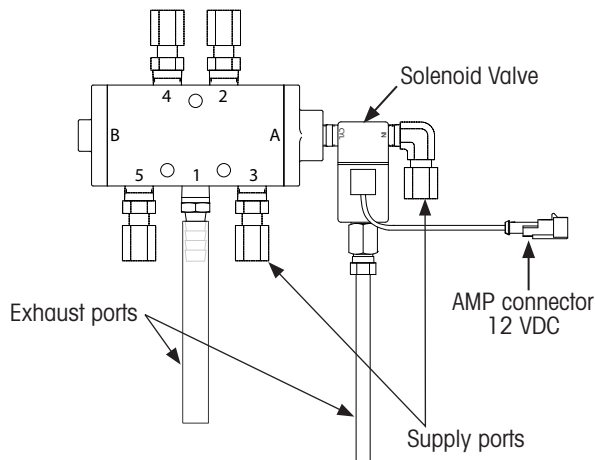

Figure 1: AKAD0012 lift valve assembly

1. **Check** for general condition of system components for bent, damaged or broken parts.
2. **Ensure:**
 - A. **Adequate voltage** is applied to trailer.

- B. AKAD0012 **valve orientation** is as shown in Figure 1, Figure 2 and Figure 3 with the exhaust ports pointing downward.
- C. Exhaust ports **exhaust freely**, tubes are present and from 4 - 6 inches in length.
- D. AKAD0012 **wires/connector** are not corroded, broken or shorted.
- E. The AKAD0012 **solenoid CYL port is facing the valve** (Figure 1).

AKAD0012 TEST PROCEDURE:

1. With **no power** connected to the trailer, verify the **axle is down**.
 - A. If the axle was up and stays **up**, replace the valve assembly.
 - B. If the axle is **down**, continue to next step.
2. **Disconnect** the AMP connector on the solenoid valve.

⚠ CAUTION: Applying and removing voltage at the solenoid valve will cause the axle to raise and lower. Keep body parts and other personnel clear of the lifting axle.

3. Using wire leads with the mating AMP connector, **directly energize** the solenoid valve with an alternative 12 VDC source (use alligator clips if a mating AMP connector is not available).
 - A. **If the axle does NOT lift**, replace the valve assembly.
 - B. **If the axle does lift**, proceed to the next step.
4. **De-energize** the solenoid valve and restore to normal operation.

If the axle does NOT lower after it is de-energized, **replace** the valve assembly.

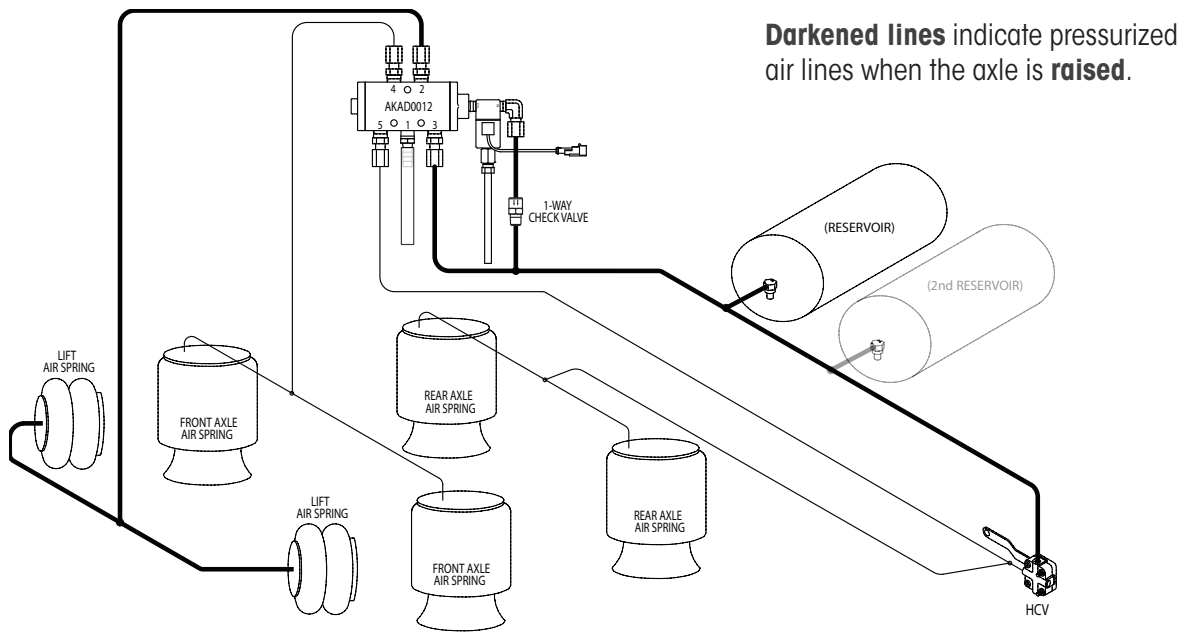

Figure 2: Tandem plumbing diagram for raised axle.

NOTE: Depending on the number of pneumatic options installed on the trailer, a second air tank or a 1-way check valve may be required.

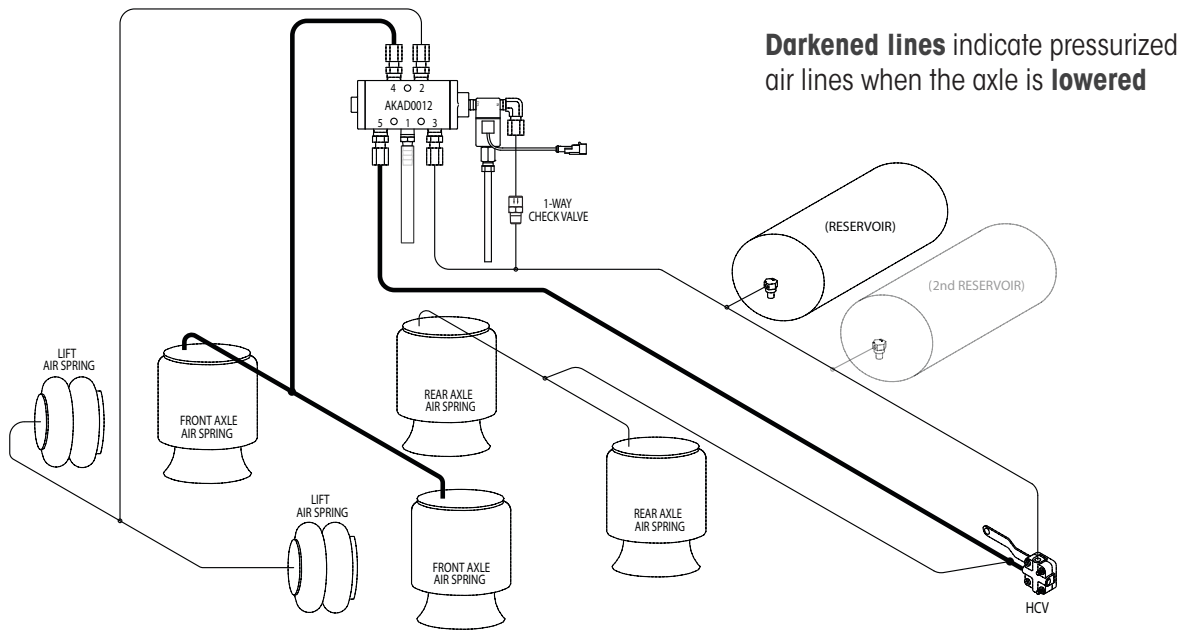

Figure 3: Tandem plumbing diagram for lowered axle.

For any questions, contact **Hendrickson Trailer Technical Services**, in the United States and Canada at 866-RIDEAIR (743-3247) or e-mail HTTS@Hendrickson-intl.com.

Call Hendrickson at **866.RIDEAIR (743.3247)** for additional information.



TRAILER COMMERCIAL VEHICLE SYSTEMS
 2070 Industrial Place SE
 Canton, OH 44707-2641 USA
 866.RIDEAIR (743.3247)
 330.489.0045 • Fax 800.696.4416

Hendrickson Canada
 250 Chrysler Drive, Unit #3
 Brampton, ON Canada L6S 6B6
 800.668.5360
 905.789.1030 • Fax 905.789.1033

Hendrickson Mexicana
 Circuito El Marqués Sur #29
 Parque Industrial El Marqués
 Pob. El Colorado, Municipio El Marqués,
 Querétaro, México C.P. 76246
 +52 (442) 296.3600 • Fax +52 (442) 296.3601

www.hendrickson-intl.com