

This Print remains the property of Hendrickson. All information contained thereon is confidential. It is loaned, subject to return on demand and on express condition that it is not to be copied or used directly or indirectly for any purpose other than the purpose for which it has been loaned to you.

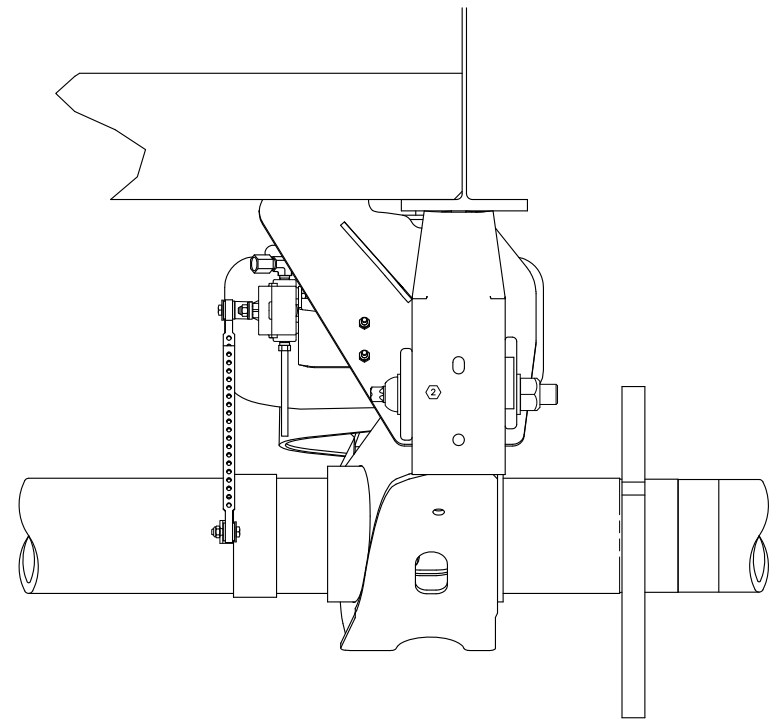
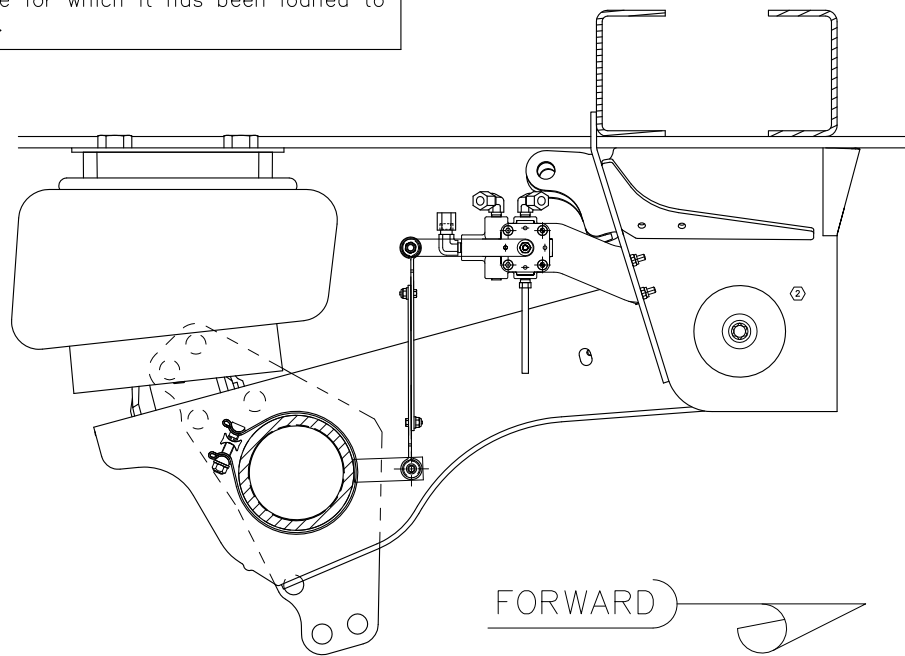

NOTE: SOME COMPONENTS NOT SHOWN FOR CLARITY.

HCV WITH DUMP			AKHD0281-3
ITEM	PART NO.	DESCRIPTION	QTY.
② 1	A-29393	HCV W/DUMP	1
2	A-14187	LINK ASSEMBLY - BOLTED	1
3	B-23293	HCV BRACKET	1
4	B-26306	HCV BRACKET ASSEMBLY	1
5	A-1128	PRESSURE PROTECTION VALVE	1
② 6	SA-4300-15	1/4 NPTF X 3/8 TUBE 90° ELBOW	1
② 7	B-26593-1	CLAMP, BAND	1
② *8	A-29870	HCV SUB-KIT (#1)	1
② *9	DWG AKHD0281	HCV AANT 5" AXLE AIR DISC	1
② *10	L-668	INSTALLATION INSTRUCTIONS	1
*11	L-373	CAUTION STICKER	1
② * NOT SHOWN		WEIGHT (LB)	3.82

OPERATION:

VALVE ARM HORIZONTAL
FRAME IS AT PRESET HEIGHT
NO AIR FLOW OCCURRING.

VALVE ARM DOWN
FRAME IS HIGH, AIR SPRINGS
ARE EXHAUSTED UNTIL ARM
IS HORIZONTAL.

VALVE ARM UP
FRAME IS LOW, AIR SPRINGS
ARE INFLATED UNTIL ARM
IS HORIZONTAL.

PARKING BRAKES SET
AIR SPRINGS ARE DUMPED
DOWN TO INTERNAL BUMPERS.

PARKING BRAKES RELEASED
AIR SPRINGS ARE INFLATED
UNTIL ARM IS HORIZONTAL.

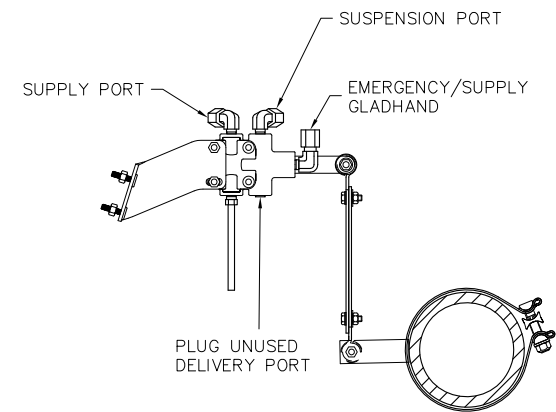
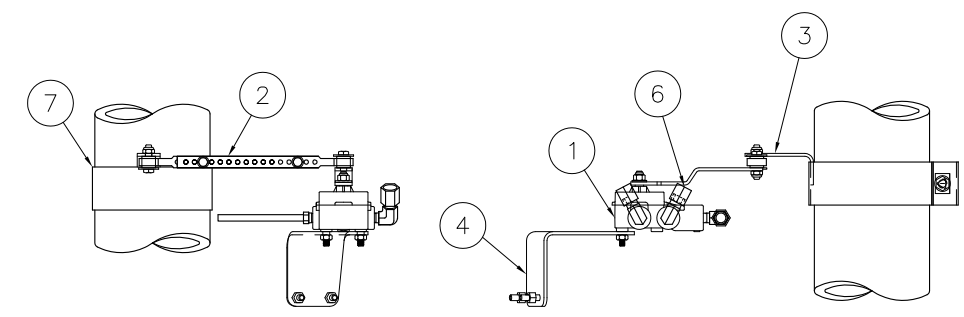

- NOTES:**
- DO NOT ADD LUBRICATION TO AIR SYSTEM.
 - ALL CONNECTIONS MUST BE LEAK PROOF.
 - AVOID BENDS IN AIR LINES.
 - AIR LINE FITTINGS AND LINES TO BE FURNISHED BY INSTALLER. 3/8" POLYIMIDE TUBING RECOMMENDED.
 - APPLICATION - ALL TRAILERS USING INTRAAX® AANT, 5" AXLE, AIR DISC READY SUSPENSION MODELS.
 - TRIM & BOLT LINKS TO 8.88" LENGTH.
 - AIR UP SUSPENSION UNTIL AXLE IS SET AT PROPER RIDE HEIGHT. INSERT LOCATING PIN IN HCV CONTROL ARM TO HOLD ARM IN NEUTRAL POSITION. INSTALL ONE END OF THE LINK TO THE HEIGHT CONTROL VALVE. INSTALL BRACKET (ITEM 3) AND THE BAND CLAMP (ITEM 7) LOOSELY ON THE AXLE. ROTATE ITEMS 3 AND 7 TO LINE UP THE MOUNTING HOLE AND THE OTHER END OF THE LINK. INSTALL LINK FASTENER AND TIGHTEN NUT. DO NOT OVER-TIGHTEN LINK FASTENER TO ALLOW THE LINK TO ROTATE FREELY. TIGHTEN THE BAND CLAMP (ITEM 7) TO 50-60 FT-LB, BEING CAREFUL NOT TO CHANGE THE ORIENTATION OF ITEM 3.
 - TO MAKE FINE ADJUSTMENTS TO RIDE HEIGHT LOOSEN HCV MOUNTING NUTS AND ROTATE VALVE BODY.
 - ALL ITEMS SHIPPED UNASSEMBLED. FITTINGS, NUTS AND BOLTS TO BE PLACED IN A PLASTIC BAG.
 - HEIGHT CONTROL VALVE SERVICE REPLACEMENT P/N VS-228.
 - RECOMMENDED AIRLINE FITTING INSTALLATION TORQUE NOT TO EXCEED 7 FT-LB.

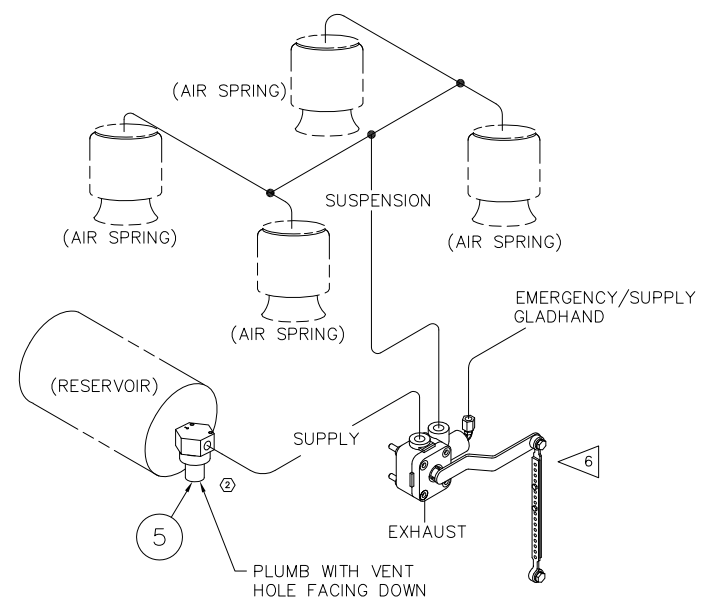
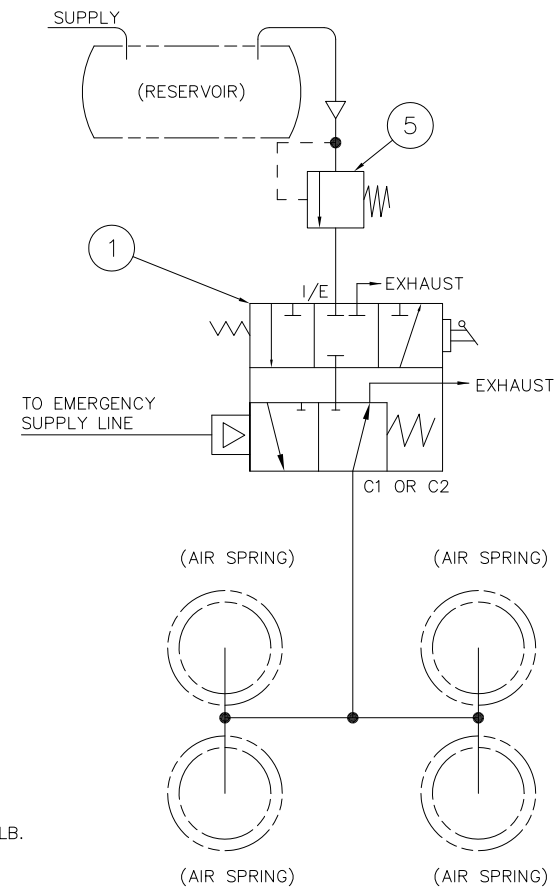

FUNCTION :

AUTOMATIC HEIGHT CONTROL.
AUTOMATIC SUSPENSION DUMP.

