

ITEM	PART NO.	DESCRIPTION	QTY.
1	A-27377-1	BAND CLAMP	1
2	C-29819	ABS BRACKET, WELD-ON	1
*3	DWG EKCH0001	WHEEL SENSOR MOUNTING KIT	1

*NOT SHOWN

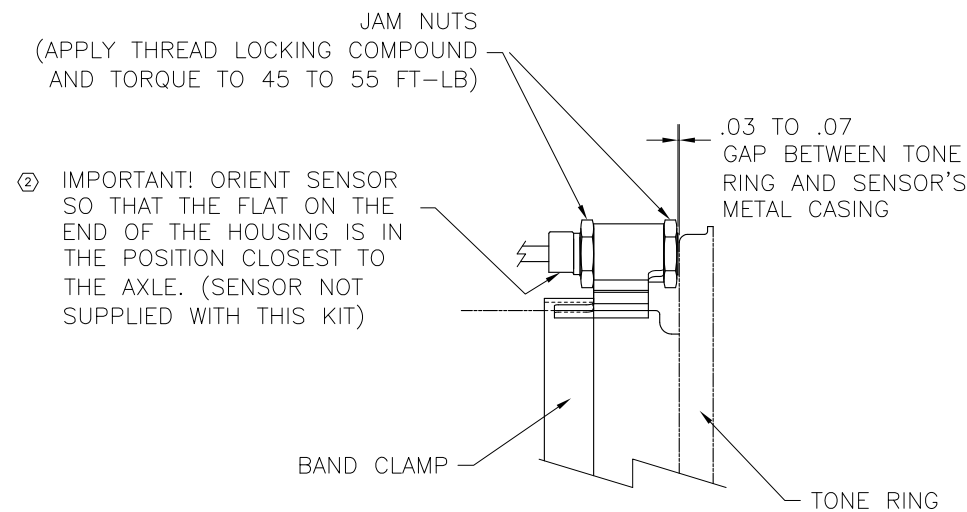

VIEW AA
SCALE: .125=1.000

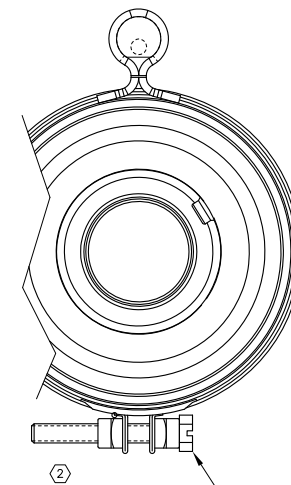

TORQUE FASTENER TO 10 FT-LB

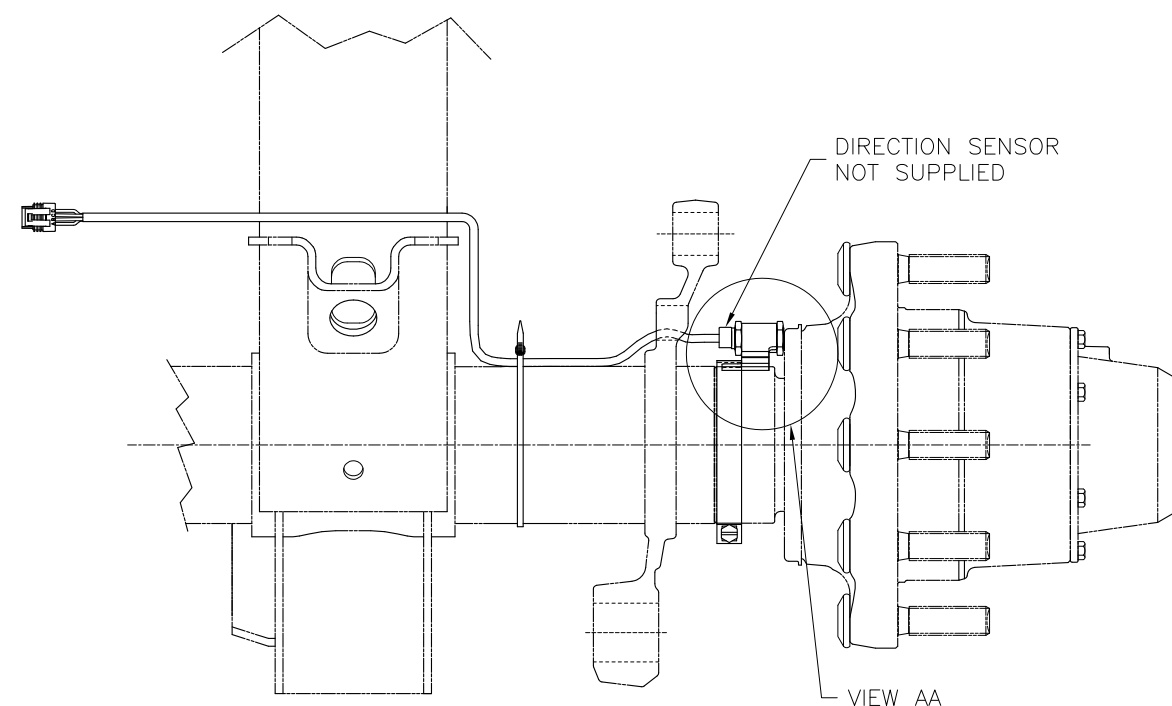
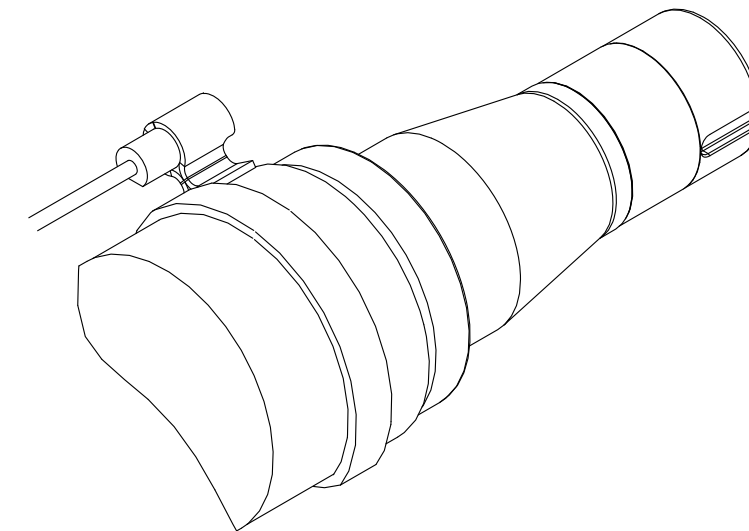

DRIVER'S SIDE WHEEL END

NOTES:

1. INSERT SENSOR INTO THE BRACKET.
2. ORIENT FLAT ON SENSOR HOUSING TOWARD THE AXLE.
3. APPLY A THREAD LOCKING COMPOUND TO THE SENSOR THREADS ON BOTH SIDES OF THE SENSOR BRACKET.
4. TIGHTEN JAM NUTS TO 45-55 FT-LB.
5. INSTALL SENSOR AND SENSOR BRACKET ON THE LEFT SIDE (DRIVER SIDE) UNLESS THE APPLICATION SPECIFIES A DIFFERENT WHEEL LOCATION.
6. SECURE THE SENSOR AND BRACKET TO THE AXLE WITH THE SUPPLIED BAND CLAMP. POSITION THE SENSOR UNTIL IT'S METAL CASE IS .03 TO .07 INCH AWAY FROM TONE RING. IF THE SENSOR IS SUPPLIED WITH THE SHIM BUTTON, THEN POSITION SENSOR WITH THE SHIM BUTTON CONTACTING THE TONE RING. THEN TORQUE THE BAND CLAMP FASTENER TO 9.0 ± 1.5 FT-LB.
7. SECURE SENSOR CABLE AND WIRE HARNESS EVERY 12 TO 16 INCHES.
8. THIS MOUNTING KIT IS DESIGNED TO WORK ON AXLES WITH A NOMINAL DIAMETER OF 5 INCHES.

This Print remains the property of Hendrickson. All information contained thereon is confidential. It is loaned, subject to return on demand and on express condition that it is not to be copied or used directly or indirectly for any purpose other than the purpose for which it has been loaned to you.



2070 INDUSTRIAL PLACE S.E. CANTON, OH 44707-2600 U.S.A.

UNLESS OTHERWISE NOTED:		DIMENSIONS ARE:	
TOLERANCES ARE:		INCHES	
.X: ± .1		2	16599 LMK 5-8-08
.XX: ± .06		1	15787 SEG 7-13-07
.XXX: ± .030		0	12205 JWC 2-14-03
ANGULAR: ± .5			

DRAWN BY	J. CERVANTEZ	DATE	12-17-02
CHK'D BY	2/19/03 K. GALIGHER		
APP'D BY:	J. WHITE		

THIS DRAWING IS THE CONFIDENTIAL PROPERTY OF HENDRICKSON

WHEEL SENSOR MOUNTING KIT

SCALE	PAGE
.25=1.00	1 OF 1
(SIZE)	DRAWING No.

EKCH0001