

BILL OF MATERIALS: UBL-			101	102
ITEM	PART NO.	DESCRIPTION	QTY.	QTY.
1	A-30634-1	LIFT ASSEMBLY BOLT KIT	1	1
2	C-23114	AIR SPRING	2	2
3	C-32893C	LIFT BRACKET	2	2
4	B-27945	BEAM PLATE ASS'Y	2	2
5	C-33350-1C	FRONT BRACKET ASSEMBLY, L.H.	1	-
5	C-33350-1GV	FRONT BRACKET ASSEMBLY, L.H.	-	1
6	C-33350-2C	FRONT BRACKET ASSEMBLY, R.H.	1	-
6	C-33350-2GV	FRONT BRACKET ASSEMBLY, R.H.	-	1
7	*A-26828	IDENTIFICATION TAG	1	1
8	*DWG D-33646	UBL-101,102	1	1
9	*A-21066	RIVET, DRIVE	1	1
10	*T-91001	UBL INFORMATION AND INSTALLATION	1	1

* NOT SHOWN
NOTES:

- 12" RIDE HEIGHT SHOWN, INSTALLATION IS SAME FOR ALL RIDE HEIGHTS.
- WEIGHT: 70.54 LB
- WELDING PARAMETERS:
NOTE: A WELDER QUALIFIED IN 2G POSITION PER ANSI/AWS D1.1-94 SECTION 5 PART C "WELDER QUALIFICATIONS" MUST PERFORM THE WELDING.

FOR ALL WELDED CONNECTIONS, USE THE FOLLOWING PARAMETERS TO ACHIEVE SPRAY ARC TRANSFER:

SURFACE PREP: THE ITEMS TO BE WELDED MUST BE AT A MINIMUM TEMPERATURE OF 60°F (16°C) AND MUST BE FREE OF MOISTURE, DIRT, SCALE, PAINT AND GREASE.

STANDARD ELECTRODE: AWS E-7018 (OVEN DRIED); .125 DIAMETER; 120-140 AMPS DC; ELECTRODE POSITIVE
.156 DIAMETER; 120-160 AMPS DC; ELECTRODE POSITIVE

STANDARD WIRE: AWS ER-70S-6; .045 DIAMETER
OPTIONAL WIRE: AWS ER-70S-3; .045 DIAMETER

VOLTS: 26 - 30 DCRP
CURRENT: 275 - 325 AMPS
WIRE FEED SPEED: 380 - 420 IPM
ELECTRODE EXTENSION: 3/4 - 1 INCH

GAS: 86 PERCENT ARGON AND 14 PERCENT CO2 AT 30 TO 35 CFH

NOTE: ANY DEVIATION FROM THESE WELDING PARAMETERS MUST BE APPROVED IN WRITING BY HENDRICKSON TRAILER COMMERCIAL VEHICLE SYSTEMS.

WELD DIRECTION:
STOP ← START →

- AAT 30K REQUIRES A CROSSOVER AIR CONTROL KIT.
- BEAM PLATE ASSEMBLIES MUST BE REMOVED TO INSTALL OR REMOVE PARKING BRAKE CHAMBERS. DOES NOT APPLY TO SERVICE BRAKE CHAMBERS.

BEAM BRACKET ASSEMBLY PROCEDURE

- LOCATING BRACKET FOR WELDING**
POSITION BEAM-MOUNTED LIFT BRACKET (ITEM-3) AGAINST BOTTOM OF BEAM. ALIGN THE CENTER HOLE AND SLOT ON THE LIFT BRACKET WITH THE LOCATING HOLES IN BEAM. USING THE (2) 3/8-16 X .75 SELF-TAPPING SCREWS, SECURE BRACKET AGAINST BEAM IN PREPARATION FOR WELDING.
- WELDING BRACKET TO BEAM**
WELD FRONT AND BOTH SIDES OF BRACKET TO BEAM AS SHOWN. LOCATING SCREWS CAN BE REMOVED AT THIS TIME.
- INSTALLING BRAKE ACTUATOR**
IF LONG-STROKE, 30/30 SPRING BRAKES ARE USED. THE REAR LOCATING SCREW MUST BE REMOVED TO PROVIDE ADEQUATE CLEARANCE. INSTALL AND UNCAGE PARKING BRAKES AT THIS TIME. THERE IS NO CAGING TOOL ACCESS FOR SPRING BRAKES AFTER THE BEAM PLATE ASSEMBLY IS BOLTED IN PLACE.
- ASSEMBLING AIR SPRING MOUNTING PLATE**
INSTALL BEAM PLATE ASSEMBLY (ITEM-4) USING (4) 1/2-13 X 1.25 HEX CAP SCREWS AND (4) 1/2-13 NUTS AND TIGHTEN TO SPECIFIED TORQUE.

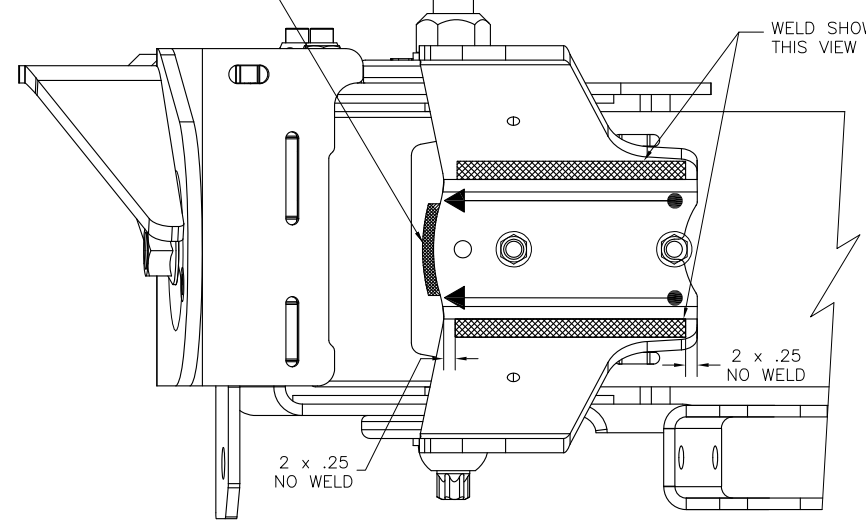
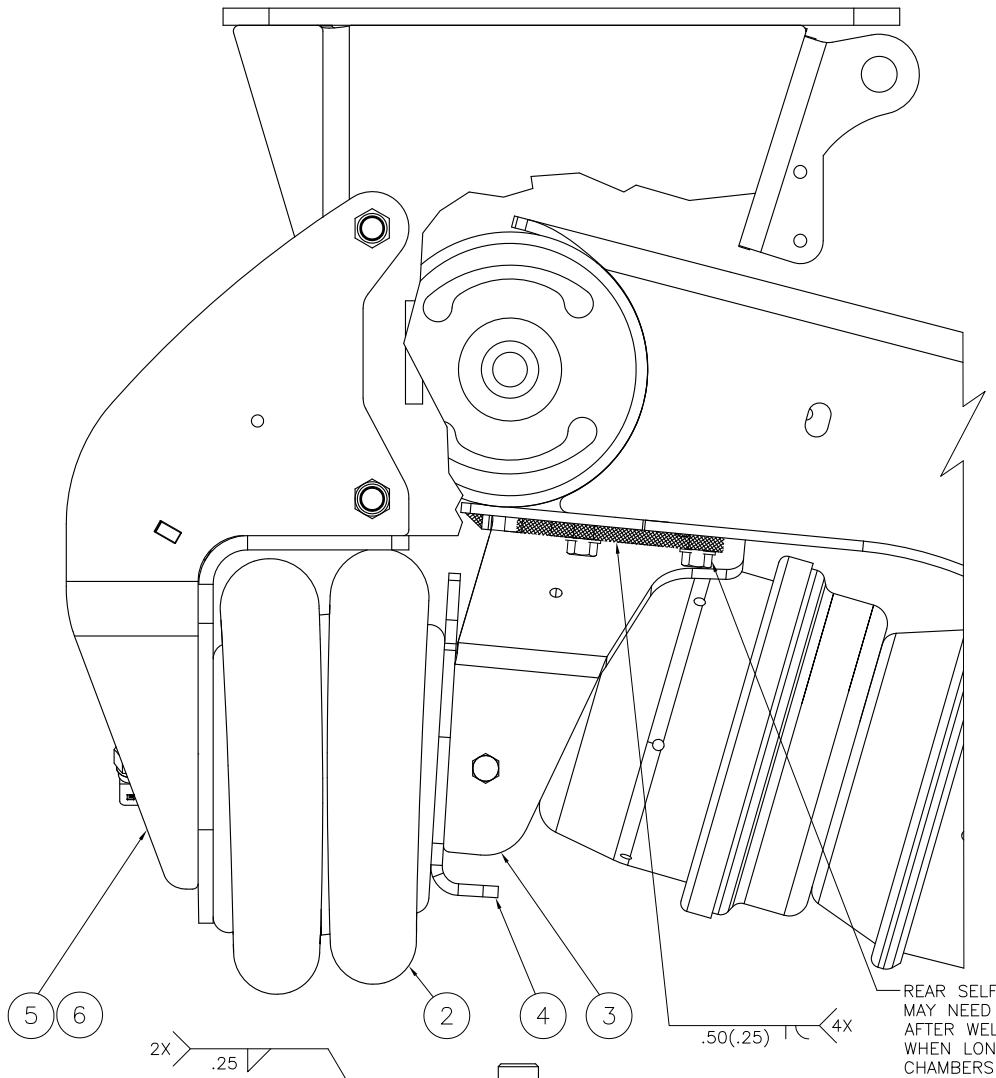
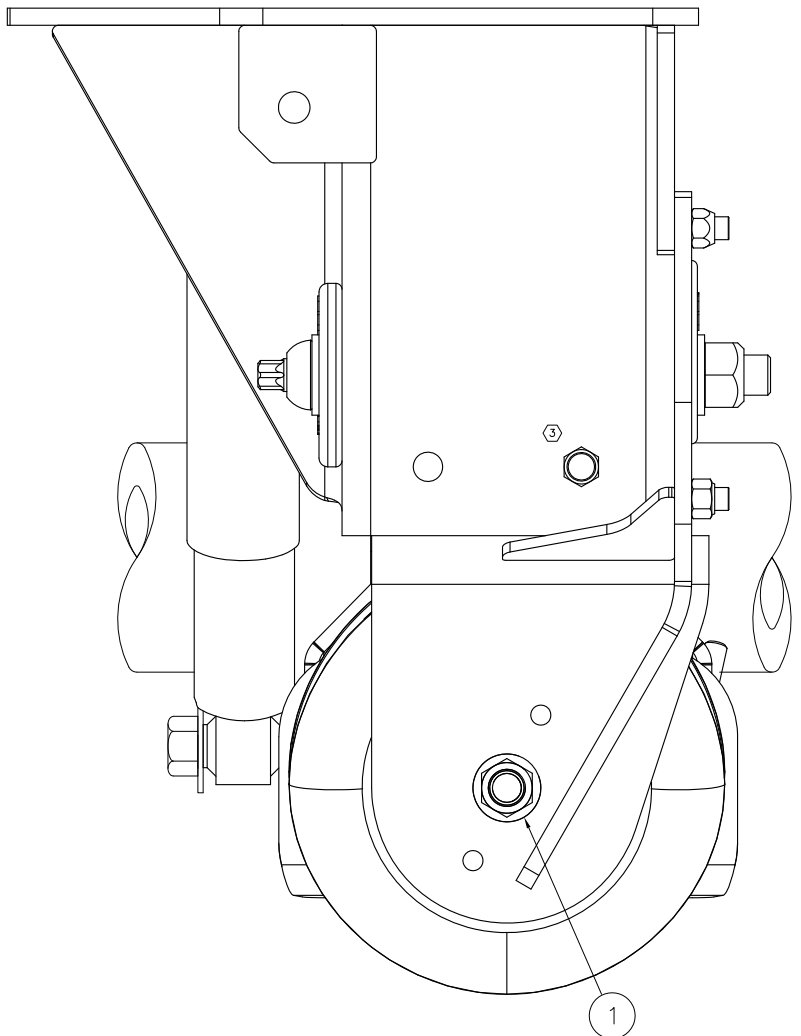
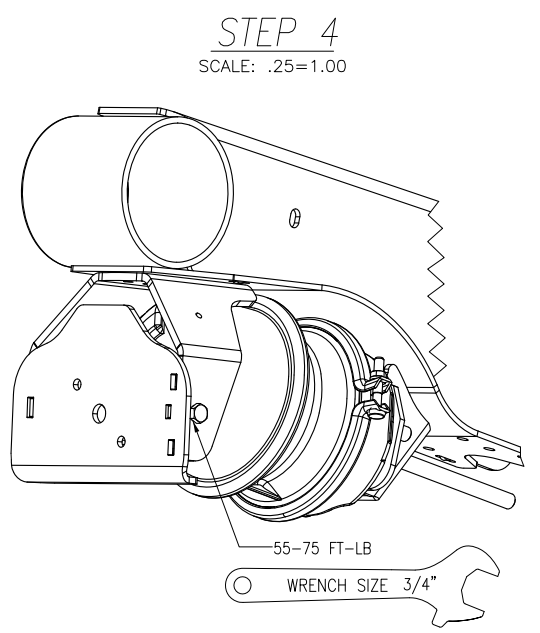
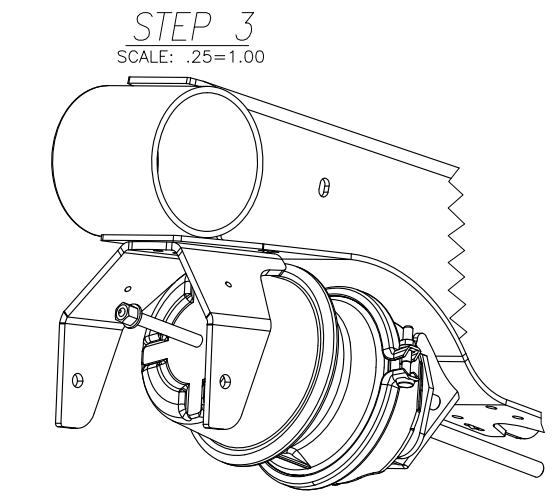
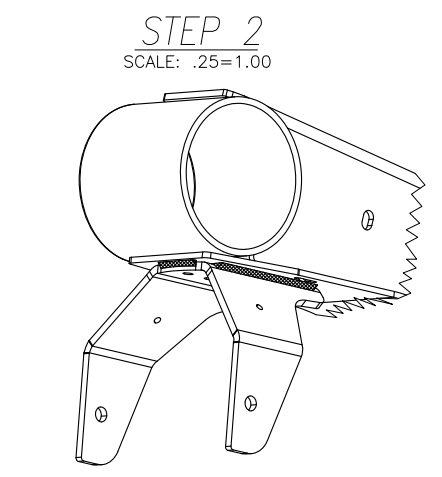
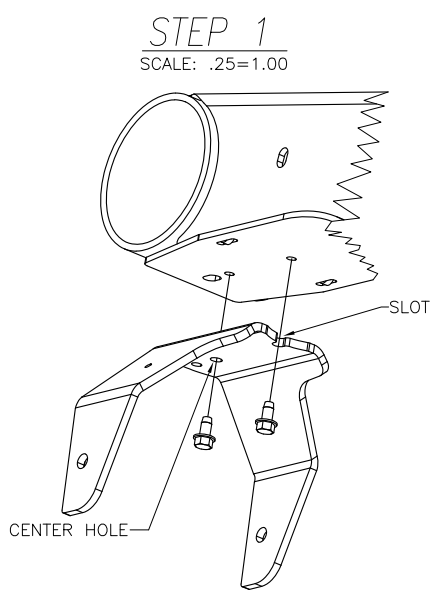

**UBL-101 AND -102
LIFT KIT FOR AAT 23/25/30K**

This Print remains the property of Hendrickson. All information contained thereon is confidential. It is loaned, subject to return on demand and on express condition that it is not to be copied or used directly or indirectly for any purpose other than the purpose for which it has been loaned to you.

STEP 1

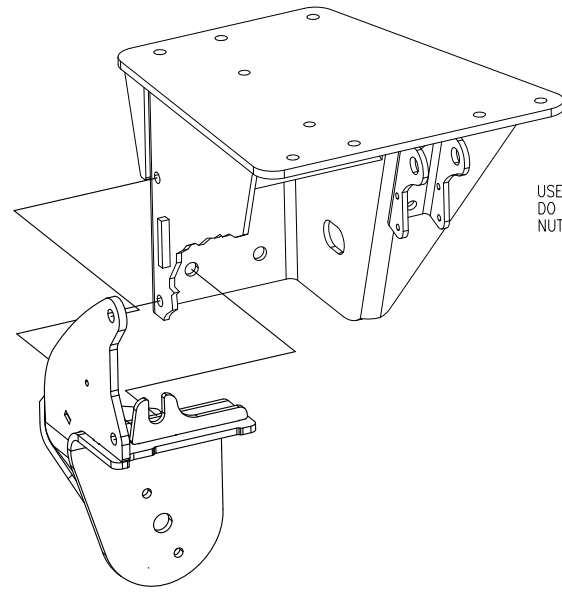

STEP 2

USE STANDARD HEX NUT
DO NOT USE TORQUE-PREVAILING
NUT FOR SEATING FASTENERS.

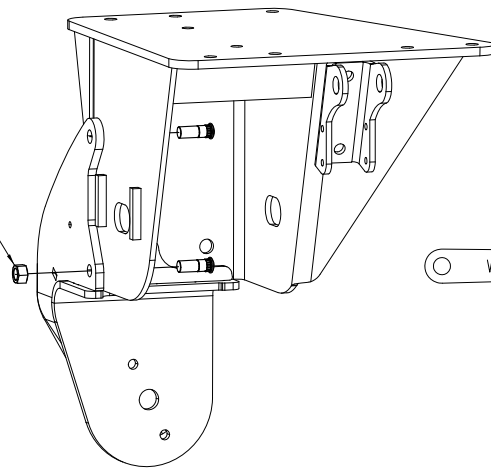

STEP 3

PREVAILING TORQUE NUT
75-85 FT-LB
WRENCH SIZE 3/4"

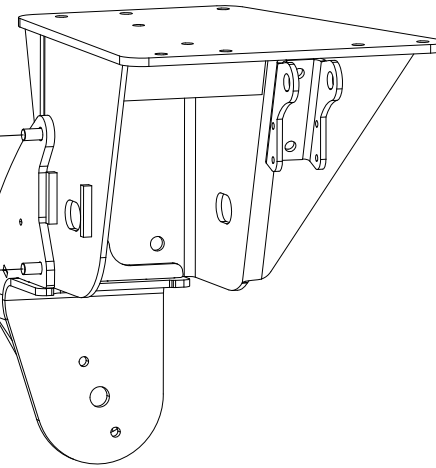

STEP 4

170-210 FT-LB
WRENCH SIZE 15/16"

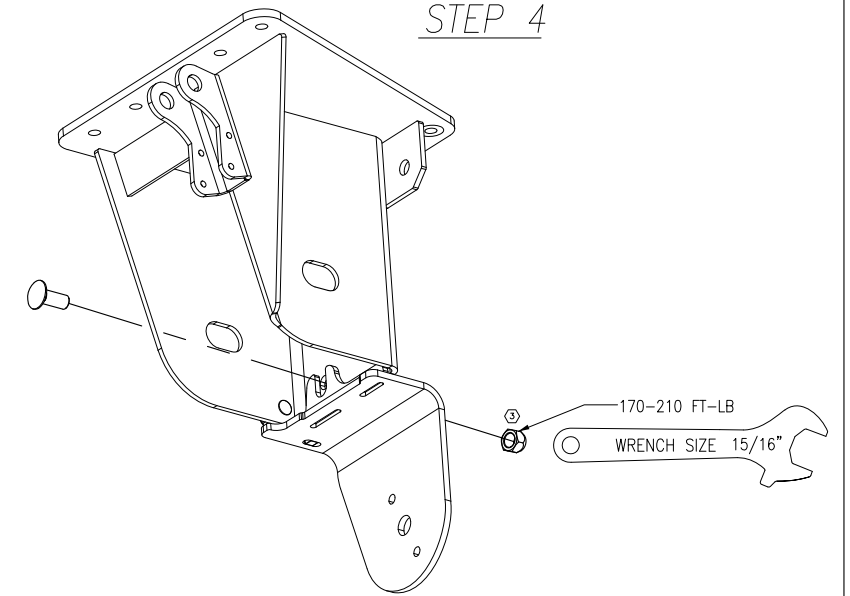

FRONT BRACKET
ASSEMBLY PROCEDURE

** FRONT BRACKET MUST BE IN PLACE BEFORE SEATING THE RIBBED-NECK BOLTS. BRACKET CANNOT BE INSTALLED IF BOLTS ARE INSTALLED PRIOR TO POSITIONING OF THE BRACKET.

1. FITTING BRACKET INTO PLACE.
SLIDE FRONT BRACKET INTO PLACE, MAKING SURE THAT ALL MOUNTING HOLES IN UBL BRACKET ALIGN WITH HOLES IN FRAME BRACKET.

2. INSERTING SIDE MOUNTING BOLTS.
HOLDING THE FRONT BRACKET IN PLACE, PUSH RIBBED NECK FASTENERS INTO MOUNTING HOLES FROM INSIDE OF FRAME BRACKET. INSERT AND TIGHTEN THE PROVIDED 1/2-13 STANDARD (NON-LOCKING) HEX NUT ON EACH RIBBED-NECK FASTENER. AS THE NUT IS TIGHTENED, THE FASTENER WILL BE DRAWN INTO THE FRAME BRACKET MOUNTING HOLES. TIGHTEN THE NUT UNTIL THE HEAD OF THE FASTENER IS FLUSH WITH THE INSIDE OF THE HANGER. (HEX NUT CAN BE REUSED TO SEAT ALL FOUR RIBBED-NECK FASTENERS. DO NOT USE PREVAILING TORQUE NUTS TO SEAT RIBBED-NECK BOLTS)

3. TIGHTENING SIDE MOUNTING BOLTS.
PLACE 1/2-13 PREVAILING TORQUE NUTS ONTO RIBBED-NECK FASTENERS AND TORQUE TO SPECIFIED VALUE.

④ 4. INSTALLING FRONT MOUNTING BOLT.
PLACE 5/8-11 X 1.50 CARRIAGE BOLT THROUGH FRONT MOUNTING HOLE WITH THE BOLT HEAD ON THE INSIDE OF THE FRAME BRACKET (NEAREST THE PIVOT BUSHING). HOLD CARRIAGE BOLT IN HOLE AND PLACE 5/8-11 TORQUE PREVAILING HEX NUT ONTO BOLT AND TORQUE TO SPECIFIED VALUE.

5. AIR SPRING ASSEMBLY.
ASSEMBLE THE AIR SPRING WITH THE AIR INLET FACING TO THE FRONT OR REAR, DEPENDING ON AIR LINE ORIENTATION PREFERENCE. TIGHTEN THE 3/4-16 FLANGE NUT AND 3/8-16 X .88 BOLTS TO SPECIFIED TORQUES.

MODIFICATIONS NECESSARY IF FRAME BRACKETS
ARE NOT EQUIPPED WITH MOUNTING HOLES

1. POSITION FRONT LIFT BRACKET ONTO SUSPENSION FRAME BRACKET.
2. OUTBOARD HOLES: USING TRANSFER PUNCH, CENTER PUNCH TO LOCATE CENTER OF FRONT LIFT BRACKET HOLES ONTO THE OUTBOARD SIDE OF THE SUSPENSION FRAME BRACKET.
3. DRILL PILOT HOLES, SIZE OPTIONAL.
4. DRILL FINISH HOLES USING 33/64" DRILL (.515" DIA.)
5. FRONT HOLE: CENTER PUNCH AT THIS LOCATION, PILOT DRILL, AND FINISH DRILL USING A 41/64" DRILL (.640" DIA.)
6. FINISH: IF FRAME BRACKETS HAVE BEEN GALVANIZED, SURFACE OF DRILLED HOLES WILL NEED TO BE SUITABLY RECOATED.

HOLE LOCATIONS

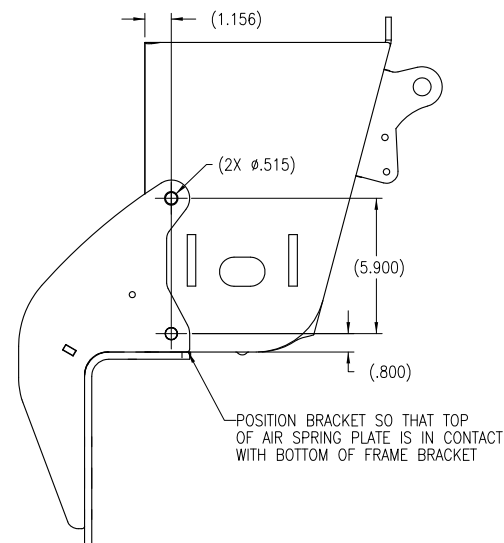

STEP 5

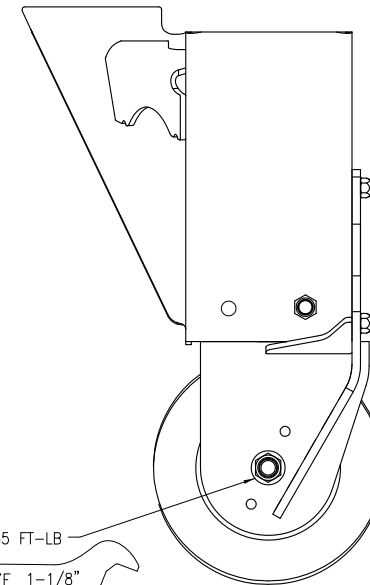

45-55 FT-LB
WRENCH SIZE 1-1/8"

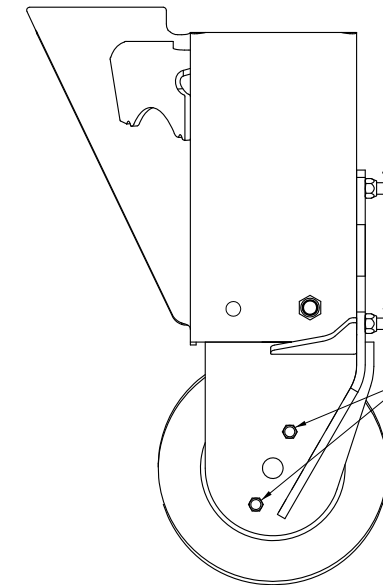

25-35 FT-LB
WRENCH SIZE 9/16"

ALTERNATE INSTALLATION:
AIR INLET TOWARD REAR OF SUSPENSION

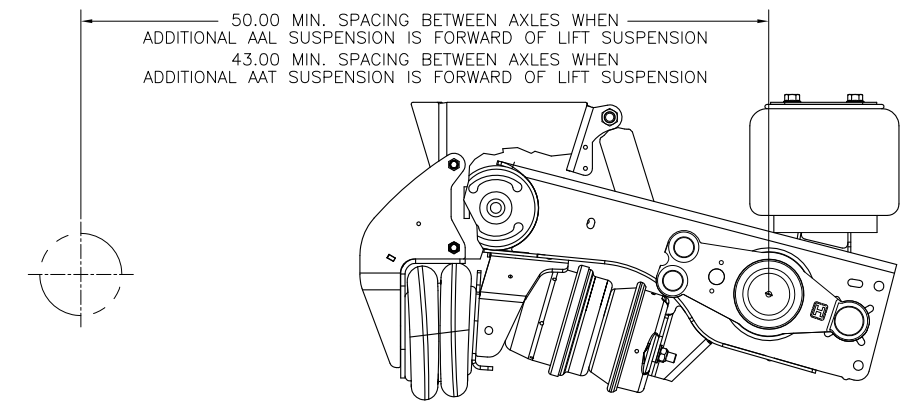

This Print remains the property of Hendrickson. All information contained thereon is confidential. It is loaned, subject to return on demand and on express condition that it is not to be copied or used directly or indirectly for any purpose other than the purpose for which it has been loaned to you.