

AVAILABLE LITERATURE

TRAILER SUSPENSION SYSTEMS

SUBJECT: Pivot-Connection Fastener
Information

LIT NO: L1072

DATE: April 2009

REVISION: A

To assist with pivot connection service, Hendrickson has made the following literature available on our website at http://www.hendrickson-intl.com/literature/pdfs_trailer_suspension.asp:

- B31 Torque Specifications
- B106 Pivot Bushing Inspection Procedure
- L427 Bushing Replacement Procedure
- L579 Alignment Procedure
- L750 Bushing Tube Spacer Inspection / Replacement Procedure

For any questions regarding pivot connection literature, contact Hendrickson at 866-743-3247 in the United States, 800-668-5360 in Canada or (52) 81-8288-1300 in Mexico.

ADDITIONAL INFORMATION

The QUIK-ALIGN® pivot connection fastener (or shear-type bolt) has been redesigned to help make the QUIK-ALIGN pivot connection tamper resistant.

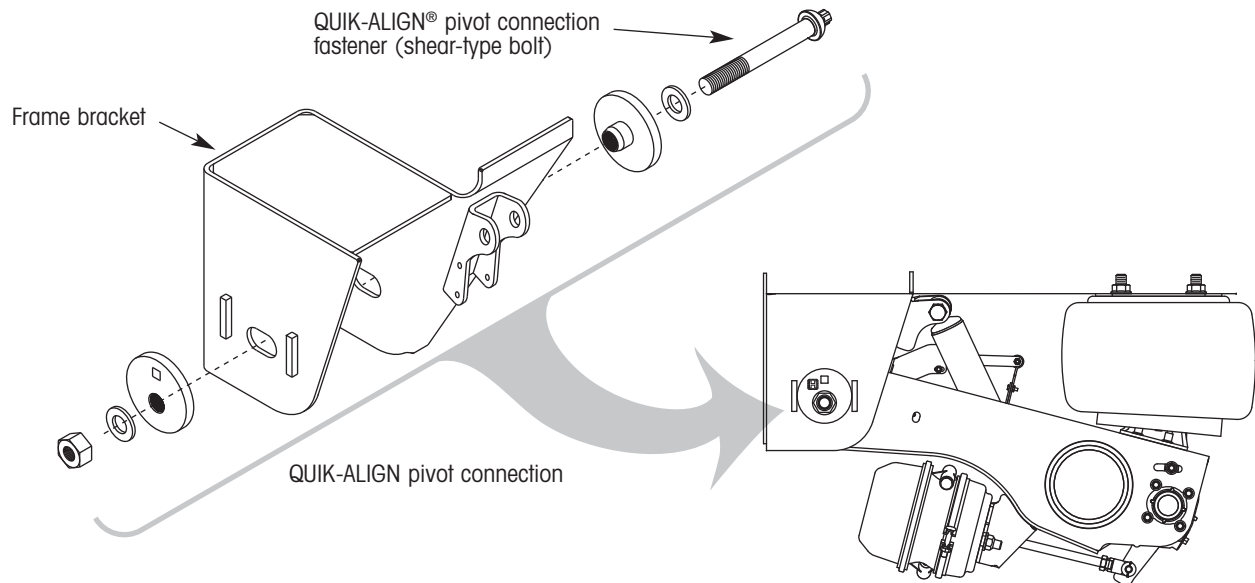

The current bolt features a round head that helps to prevent reuse. Applying the proper torque and clamp force at the pivot connection is the same as it has always been. Simply install the bolt from the inboard side of the frame bracket and tighten with a Torx™ socket until the bolt's Torx head shears off. To avoid damaging the splines on the shear bolt's Torx head, make sure the drive socket fully engages the Torx head.

For The Road Ahead

 **HENDRICKSON**

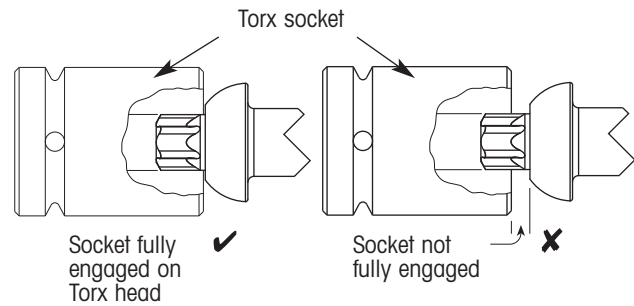
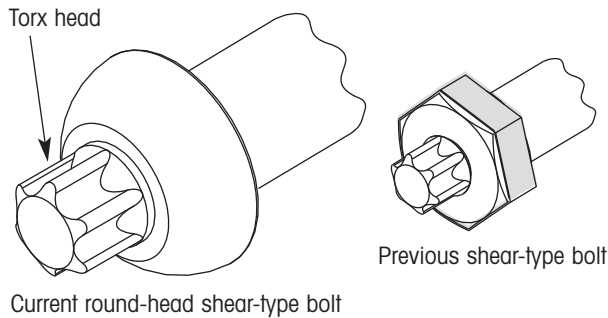

DESCRIPTION	DRIVE SIZE	PIVOT CONNECTION	COMMENTS
E20 Torx Socket (part # A-24303)	3/4"	QUIK-ALIGN®	For occasional use (not recommended for high-volume trailer production environments)
E20 Torx Socket (part # A-24536)	1"	QUIK-ALIGN	For medium-duty use (dealers, repair facilities, etc.)
E20 Torx Socket with sleeve (part # A-25119)	1"	QUIK-ALIGN	For high-volume trailer production environments or manufacturing facilities. The sleeve provides greater operator control.
E22 Torx Socket (part # SR1TL100)	1"	AdVANTage	For AdVANTage style pivot connections in high-volume trailer production environments or manufacturing facilities.

TORX SOCKETS

Hendrickson offers four Torx sockets that may be used during pivot connection assembly (refer to chart at left).

⚠ CAUTION: DO NOT apply an anti-sieze compound to the pivot connection hardware or allow undercoating, paint, or any other commonly used compounds to contact the threads of the pivot connection fasteners. These compounds can act like a lubricant, reducing the friction between the threads of the nut and bolt. This can lead to overtightened fasteners, unpredictable pivot connection clamp loads and unreliable axle alignments.

ALIGNMENT RECOMMENDED

Hendrickson strongly recommends an alignment following any pivot connection service. Refer to Hendrickson publication L579, *Alignment Procedure*, for complete alignment and pivot connection reassembly instructions.

HENDRICKSON DOES NOT AUTHORIZE REUSE OF THE BOLT

The shear-type bolt may not be reused. Whenever the pivot connection is disassembled, the existing shear-type bolt must be removed by grinding or any other appropriate method and discarded, along with the existing hex nut. A new shear-type bolt and hex nut must be installed and sheared to achieve the proper pivot connection torque and clamp force. Anyone who assembles or reassembles the pivot connection (OEMs, dealers, repair facilities, etc.) is responsible for the proper installation of the shear-type bolt. Failure to reach the required torque can result in an insufficient clamp force, unreliable axle alignment, injury or property damage.

www.hendrickson-intl.com



Trailer Suspension Systems
250 Chrysler Drive, Unit #3
Brampton, ON Canada L6S 6B6
905.789.1030
Fax 905.789.1033

Trailer Suspension Systems 866.RIDEAIR (743.3247)
2070 Industrial Place SE 330.489.0045
Canton, OH 44707-2641 USA Fax 800.696.4416

Trailer Suspension Systems
Av. Industria Automotriz #200
Parque Industrial Sliva Aeropuerto
Apodaca, N.L., México C.P. 66600
(52) 81 8288 1300
Fax (52) 81 8288 1301